

4

3

2

1

D

D

C

C

B

B

A

A

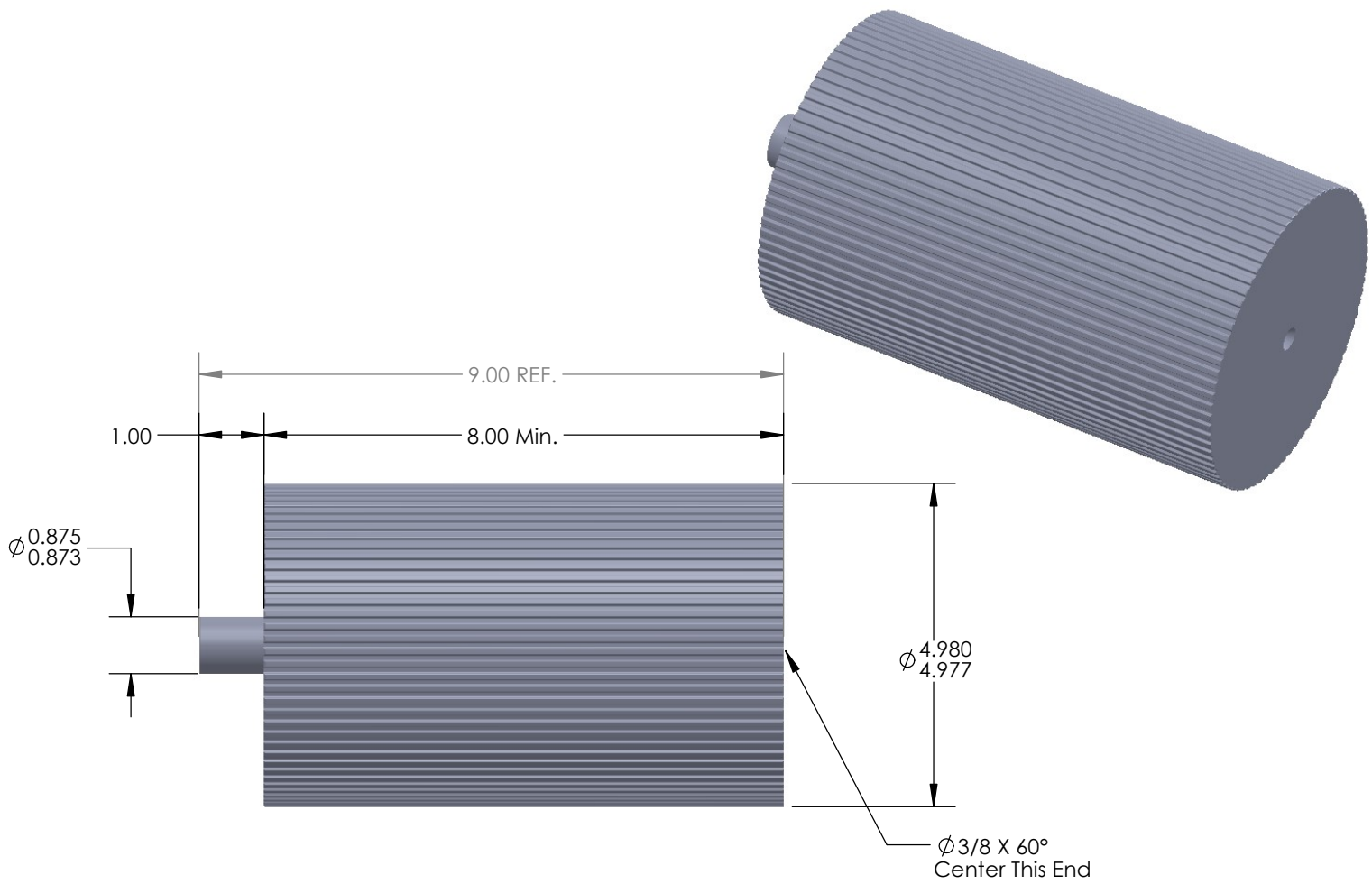

DO NOT SCALE DRAWING Flanges:	Tooth Information: T5 80 Teeth	UNLESS OTHERWISE SPECIFIED: DIMENSIONS ARE IN INCHES TOLERANCES: FRACTIONAL ± 0.015 ANGULAR: MACH $\pm 1^\circ$ BEND $\pm 2^\circ$ TWO PLACE DECIMAL ± 0.010 THREE PLACE DECIMAL ± 0.005 SURFACE FINISH: $\sqrt{63}$	Serial # of Hob Used:	 Illinois Pulley & Gear, Inc. 611 Lunt Ave., Schaumburg, IL 60193 TITLE: T5 Aluminum Pulley Stock 80 Teeth
	Inspection Notes:		Flanges Installed:	
PROPRIETARY AND CONFIDENTIAL THE INFORMATION CONTAINED IN THIS DRAWING IS THE SOLE PROPERTY OF ILLINOIS PULLEY & GEAR, INC. ANY REPRODUCTION IN PART OR AS A WHOLE WITHOUT THE WRITTEN PERMISSION OF ILLINOIS PULLEY & GEAR, INC. IS PROHIBITED.		MATERIAL 5 1/4" Rd. 6061 Aluminum FINISH None - As Machined	Sundries Installed:	SIZE DWG. NO. REV A 80-T5-PS-8A 01
			COMMENTS: 1. Break all sharp corners.	SCALE: 1:2 WEIGHT: SHEET 1 OF 1

4

3

2

1