

4

3

2

1

D

D

C

C

B

B

A

A

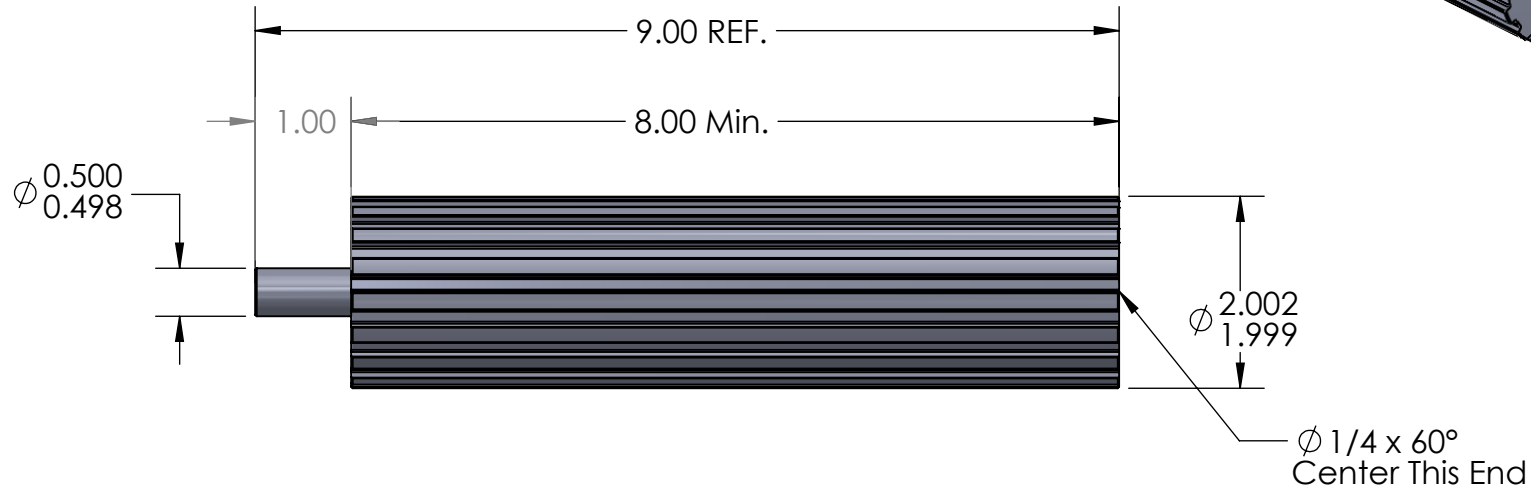
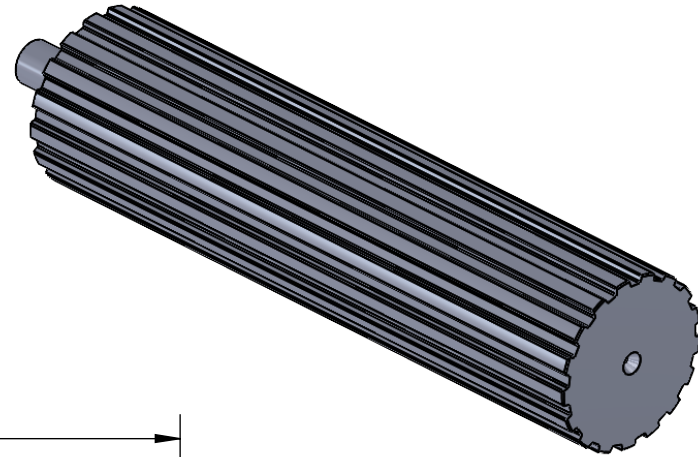

DO NOT SCALE DRAWING	Flanges:	Tooth Information: L 17 Teeth	UNLESS OTHERWISE SPECIFIED: DIMENSIONS ARE IN INCHES TOLERANCES: FRACTIONAL ±0.015 ANGULAR: MACH ±1° BEND ±2° TWO PLACE DECIMAL ±0.010 THREE PLACE DECIMAL ±0.005 SURFACE FINISH: $\sqrt{63}$	Serial # of Hob Used:	 Illinois Pulley & Gear, Inc. 611 Lunt Ave., Schaumburg, IL 60193 TITLE: L Aluminum Pulley Stock 17 Teeth	
	PROPRIETARY AND CONFIDENTIAL THE INFORMATION CONTAINED IN THIS DRAWING IS THE SOLE PROPERTY OF ILLINOIS PULLEY & GEAR, INC. ANY REPRODUCTION IN PART OR AS A WHOLE WITHOUT THE WRITTEN PERMISSION OF ILLINOIS PULLEY & GEAR, INC. IS PROHIBITED.			Inspection Notes:		MATERIAL 2 1/8" Rd. 6061 Aluminum
FINISH None - As Machined		Plating / Surface Treatment Performed:	A		17-L-PS-8A	01
COMMENTS: 1. Break all sharp corners.		Sundries Installed:	SCALE: 1:2		WEIGHT:	SHEET 1 OF 1

4

3

2

1