

4

3

2

1

D

D

C

C

B

B

A

A

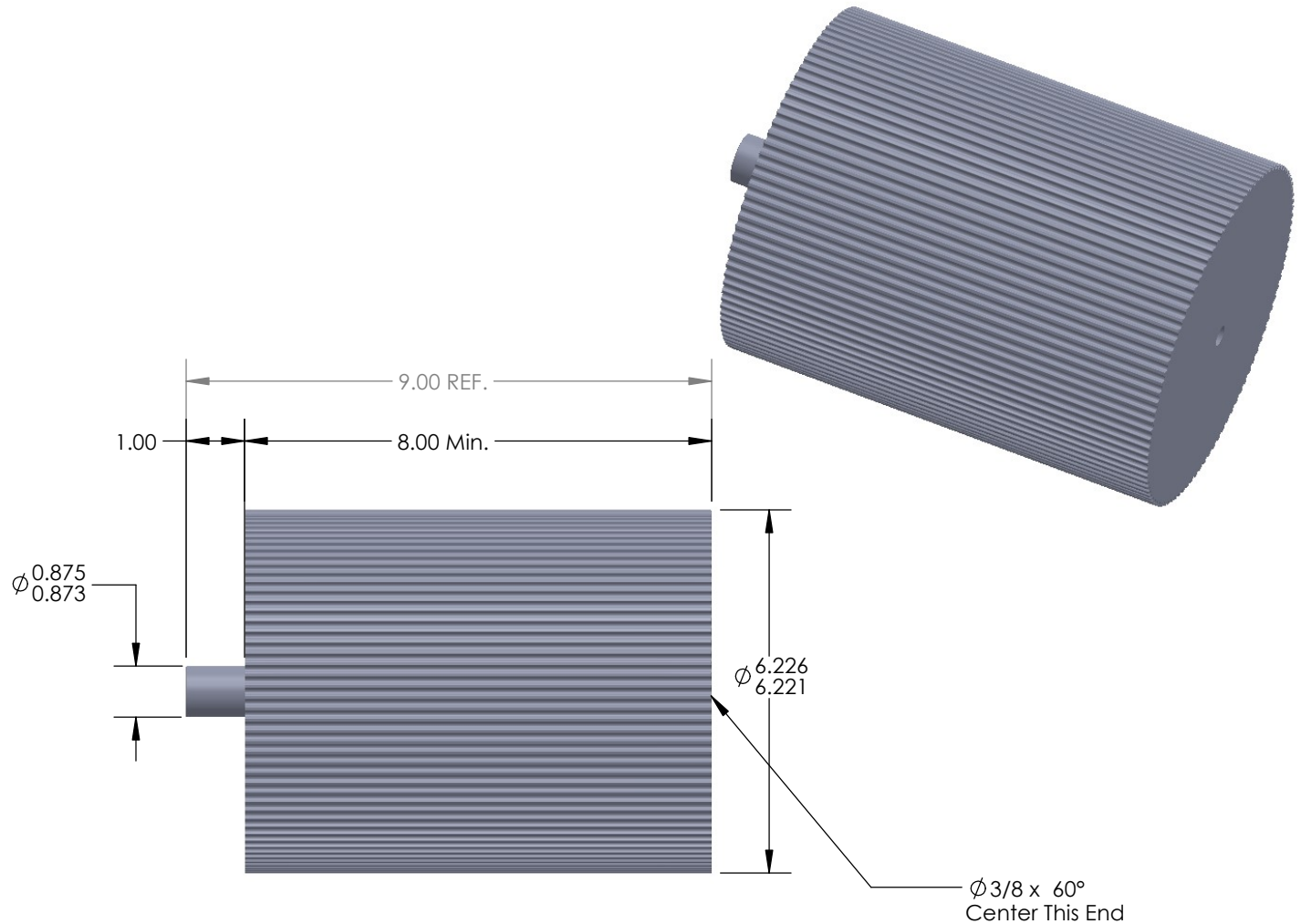

$\phi 3/8 \times 60^\circ$
Center This End

DO NOT SCALE DRAWING

Flanges:

PROPRIETARY AND CONFIDENTIAL
THE INFORMATION CONTAINED IN THIS DRAWING IS THE SOLE PROPERTY OF ILLINOIS PULLEY & GEAR, INC. ANY REPRODUCTION IN PART OR AS A WHOLE WITHOUT THE WRITTEN PERMISSION OF ILLINOIS PULLEY & GEAR, INC. IS PROHIBITED.

Tooth Information:
5mm PowerGrip GT
100 Teeth

Inspection Notes:

UNLESS OTHERWISE SPECIFIED:
DIMENSIONS ARE IN INCHES
TOLERANCES:
FRACTIONAL ± 0.015
ANGULAR: MACH $\pm 1^\circ$ BEND $\pm 2^\circ$
TWO PLACE DECIMAL ± 0.010
THREE PLACE DECIMAL ± 0.005
SURFACE FINISH: $\sqrt{63}$

MATERIAL
6 1/2" Rd. 6061 Aluminum

FINISH
None - As Machined

Serial # of Hob Used:

Flanges Installed:

Plating / Surface Treatment Performed:

Sundries Installed:

COMMENTS:
1. Break all sharp corners.

IPG Illinois Pulley & Gear, Inc.
611 Lunt Ave., Schaumburg, IL 60193

TITLE:
5mm PowerGrip GT
Aluminum Pulley Stock
100 Teeth

| | | |
|----------|---------------|-----|
| SIZE | DWG. NO. | REV |
| A | 100-5MR-PS-8A | 01 |

SCALE: 1:2 WEIGHT: SHEET 1 OF 1

4

3

2

1