



APPLICATIONS



TOILET



HAND BASIN



BATH



SHOWER



WASHING MACHINE



DISH WASHER



KITCHEN SINK

Sanicubic® 1 GR

Sanicubic® 1 GR is ideal for sloping waterfront properties where a boathouse could be converted to run amenities or rural properties where main drainage is too far away. It features a powerful 2200W motor, high flow rate performance, and an IP68 waterproof rating.

PRODUCT REFERENCE:
SA300

WHY CHOOSE THIS PRODUCT?

Compact dimensions

Tough, reliable macerating lifting station

Intelligent level controller

32 mm non-return ball valve

External hard wired audio visual alarm

Features integrated non-return valves

Will handle up to 55°C intermittent

IP68 rated

VERTICAL/HORIZONTAL PERFORMANCE

Increase size of horizontal run by one pipe size after 5m. All horizontal pipework requires a minimum of 1:100 fall.

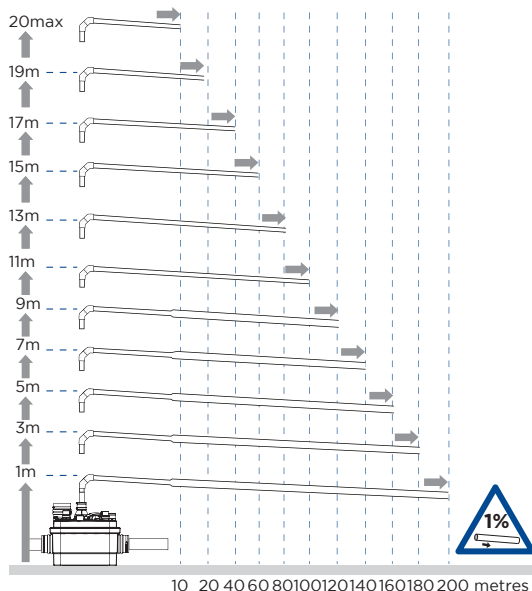

TECHNICAL CHARACTERISTICS

Discharge Pipework	40 mm
Motor Power	2200 Watts
Flow Rate	17 m ³ /h
Voltages	220-240 V/50 Hz
Tank Volume	55 L
Working Waste Water Temp	55°C Max (intermittent)
Product Weight	64 kg
Overall Measurements	570 x 439 x 460 mm
Inlet Pipework	50/100 mm
IP Rating	IP68

FLOW RATE PERFORMANCE CHART

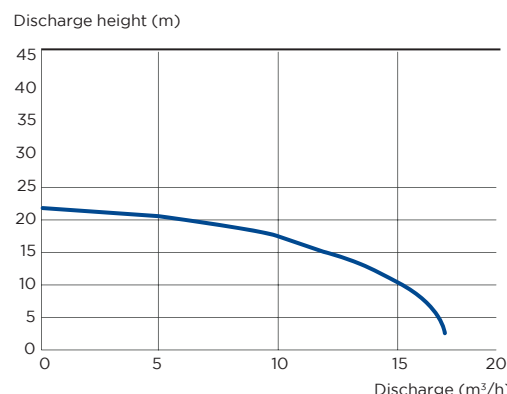



The controller system is operated via program settings which are displayed on the LCD screen. All settings are saved so that they are available when the control system is restarted. The display language can be changed. Besides the actual operational parameters, the controller system also saves the controlling process and records any irregularities which can be displayed on the LCD screen.

CONTROLLER CHARACTERISTICS

Clear LCD display

Internal acoustic alarm

Programmable operation and fault signal

Maintenance interval counter

Recording of the fault protocol

Electronic monitoring of the motor current

Internal pressure sensor

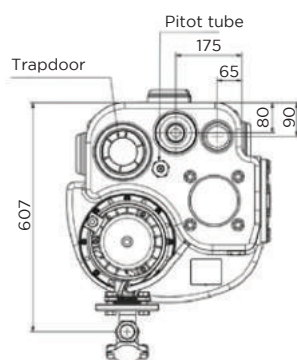
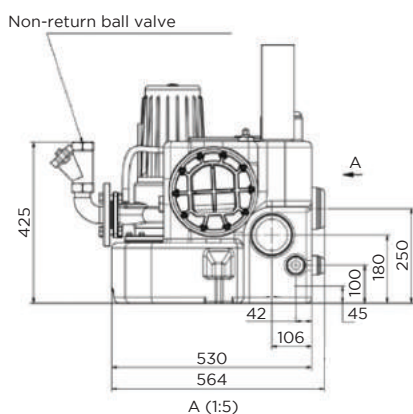

Flexible connection piece DN 65 for vent pipe

Input 100 / DN 50

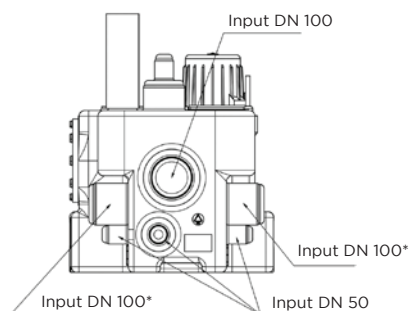
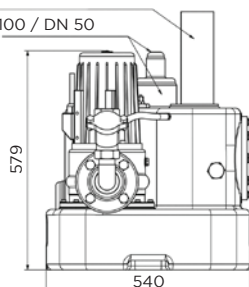

*This entrance must be directed at a height of 250 mm above the ground level directly after the lifting station.

APPLICATIONS



TOILET



HAND BASIN



BATH



SHOWER



WASHING MACHINE



DISH WASHER



KITCHEN SINK

PRODUCT REFERENCE:
SA300

 **SFA** GROUP
Shaking up water

Made in France to the highest standards, needs to be installed by a licensed plumber