

CLAM® FLANGE SHOWER KIT 16 RH

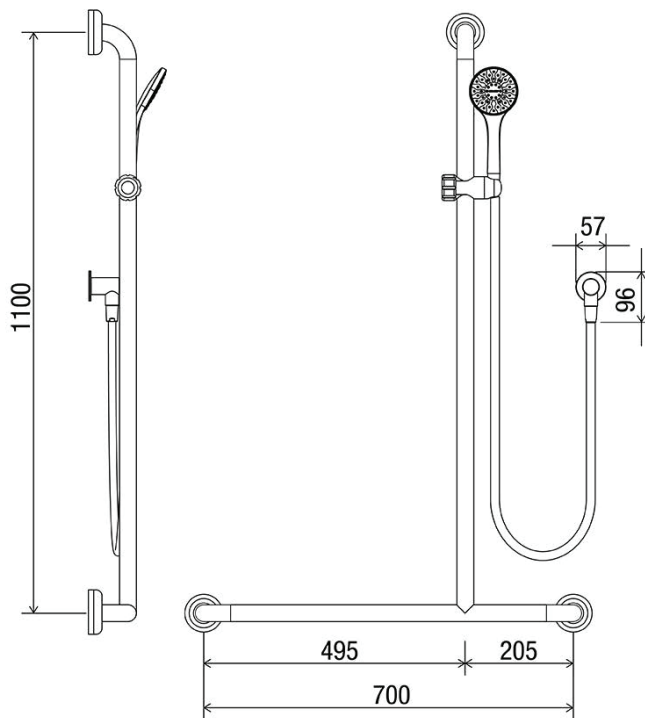

CF 01816 C RH
Chrome



CF 01816 CC RH
Commercial Chrome

Features

- 700mm x 1100mm grab rail
- 78mm pre-formed domed Clam® Flange
- ABS Glide Slide handset cradle
- Hoscare® handpiece with Polygiene Biomaster™ antimicrobial additive
- Chrome plated DR brass wall outlet elbow
- Flow interchange® spigot
- Licenced dual check/non-return as per WaterMark AS/NZS 2845.1 WMKA 02696
- 57mm solid brass round flat flange
- 1500mm Silverflex PVC shower hose
- Meets the requirements of AS 1428.1:2021 Design for access & mobility
- Options available on request - ABS Grab Rail Soap dish holder



WELS Registration
No.S17318



AS 3662
WMKT 21147



AS/NZS 2845.1
WMKA 02696



CON-SERV CORPORATION AUSTRALIA PTY. LTD.

17 Glentanna Street, Kedron Qld 4031 Australia

Phone: +61 (0)7 3630 5744–Fax: +61 (0)7 3630 5755–Email: mail@con-serv.com.au–www.con-serv.com.au