

**CLAM® FLANGE SHOWER KIT 9 - 2m SHOWER HOSE**

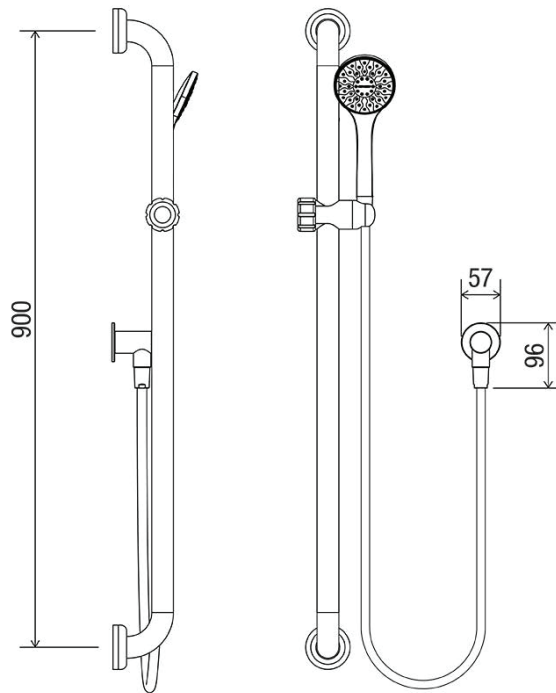

CF 01809 C2  
Chrome



CF 01809 CC2  
Commercial Chrome

**Features**

- 900mm grab rail
- 78mm pre-formed domed Clam® Flange
- ABS Glide Slide handset cradle
- Hoscare® handpiece with Polygiene Biomaster™ antimicrobial additive
- Chrome plated DR brass wall outlet elbow
- Flow interchange® spigot
- Licenced dual check/non-return as per WaterMark AS/NZS 2845.1 WMKA 02696
- 57mm solid brass round flat flange
- Silverflex PVC shower hose
- WaterMark AS/NZS 3662 WMKT 21147
- Meets the requirements of AS 1428.1:2021 Design for access & mobility
- Options available on request - ABS Grab Rail Soap dish holder



WELS Registration  
No.S17318



**WaterMark**  
AS 3662  
WMKT 21147



**WaterMark**  
AS/NZS 2845.1  
WMKA 02696



CON-SERV CORPORATION AUSTRALIA PTY. LTD.

17 Glentanna Street, Kedron Qld 4031 Australia

Phone: +61 (0)7 3630 5744–Fax: +61 (0)7 3630 5755–Email: mail@con-serv.com.au–www.con-serv.com.au