

Red Dragon E-Z Hitch Tow Bar Mounting and Operating Instructions

The Red Dragon E-Z Hitch Tow Bar is bolted to the frame of pickup trucks and similar sized vehicles.

All necessary hardware for installing the Red Dragon E-Z Hitch is packaged and included in the carton. The hardware package includes the following:

- 4 - 7/16" Bolts, Nuts & Lock-Washers
- 1 - Hitch Pin & Hairpin Clip

Mounting Instructions:

1. Measure the distance between the centers of the two frame members of the vehicle.
2. Center the above measurement on the hitch mounting plate to determine the correct placement of the four bolt holes. The pre drilled bolt holes on the EZ 203-B are at 25.75", 29" and 32".

IMPORTANT: There should be at least 3/8" clearance between the Red Dragon E-Z Hitch crossbar and the nearest point of contact with the bumper (usually the mounting bolt heads). Refer to Figure 1 below. This clearance is necessary to allow the hinge sleeves to slide unobstructed along the hitch cross bar.

3. Drill holes in the hitch mounting plate.
4. Clamp the E-Z hitch to the front of the vehicle to establish proper location for mounting on the frame.
5. With the E-Z hitch positioned as described above, fasten clamps securely and use the hitch mounting plate as a template to drill holes in the frame.
6. Install and tighten the four mounting bolts.

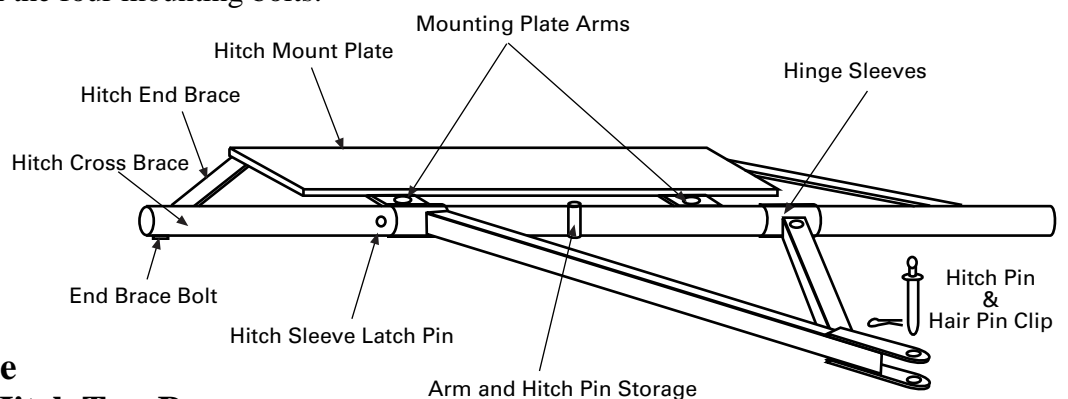
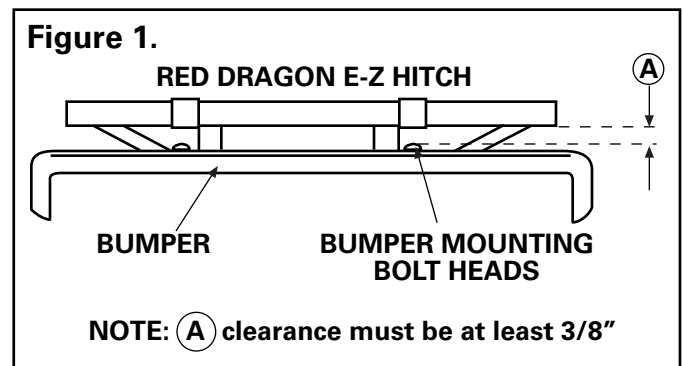

Maintenance of the Red Dragon E-Z Hitch Tow Bar

Due to the simple and rugged construction of the Red Dragon E-Z hitch Tow Bar, a minimum amount of care is required to maintain top operating condition. A few drops of oil in the hinge joints and on the points of the hinge sleeve latch pins, especially during the first few weeks of use, will greatly aid in smoothness of operation. Also, a coat of wax applied to the hitch crossbar will ease the sliding of the hinge sleeves along the bar.

Hookup and Unhooking Instruction on Reverse Side

To Hookup Your Red Dragon E-Z Tow Hitch

1. Remove hair pin clip from storage position on the hitch arm.
2. Pull hitch clevis out and align with tow point on towing vehicle.
3. Pin hitch to towing vehicle and secure with hairpin clip.
4. Make sure towed vehicle's parking brake is set.
5. Pull towing vehicle forward to extend and engage E-Z Tow. Hinge sleeve latch pin should lock in place.
6. Release parking brake in towed vehicle and make sure it is in neutral.
7. Start out slowly and apply brakes gently. Make turns slowly.

NOTE: Hitch should be parallel to the ground for proper towing.

NOTE: The Red Dragon E-Z Hitch is designed for SLOW speed (20 mph or less) agricultural towing and is NOT intended for high speed highway towing.

WARNING: Hitch hinge sleeve latch pins disengage at approximately 45° up from horizontal. If this occurs while towing, damage to both vehicles and possible injury can occur. Do not pull through steep inclines.

- A – Proper Towing Angle 0°
- B – Lowest acceptable towing angle -15°
- C – Highest acceptable towing angle $+15^\circ$
- D – Depicts hinge sleeve latch pin disengage angle

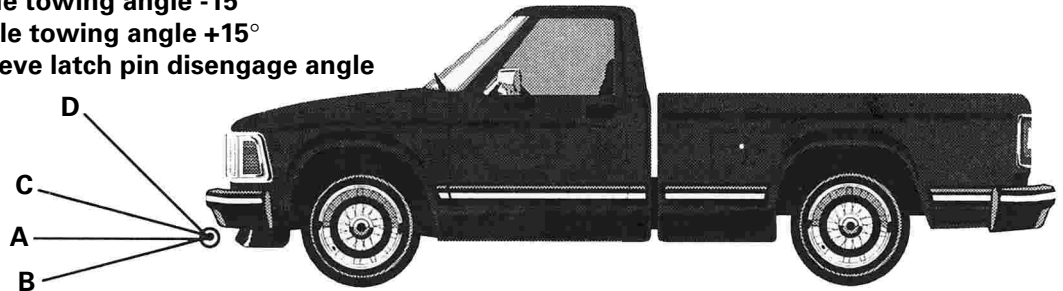

To Unhook and Stow Your Red Dragon E-Z Tow Hitch

1. Remove hair pin and hitch pin from E-Z clevis and towing vehicle.
2. Move hitch arms to a near-vertical position to disengage hinge sleeve latch pin.
3. Retract arms.
4. Continue to retract arms while lowering to a horizontal position.
5. Align hitch arm pinhole with pin holder on crossbar and secure with hitch pin. Install hair pin safety clip.



FLAME ENGINEERING, INC. • P.O. Box 577 • West Highway 4 • LaCrosse, KS 67548
800-255-2469 • 785-222-2873 • Fax: 785-222-3619 • www.FlameEngineering.com