

RED DRAGON MANUAL PROPANE FLARE

Assembly and Operating Instructions

Model: PFM-16 LPS – 1/2" Flare – Approx 529 gallons/hr



The RED DRAGON PROPANE FLARE is designed for the evacuation of LP liquid or vapor only. Its use for the evacuation of any other gases or flammable liquids is strongly discouraged and cancels any warranties or perceived responsibility of FLAME ENGINEERING, INC.

Read this manual and any other safety-related information before assembling, operating or maintaining your RED DRAGON PROPANE FLARE: Save this manual for future reference.

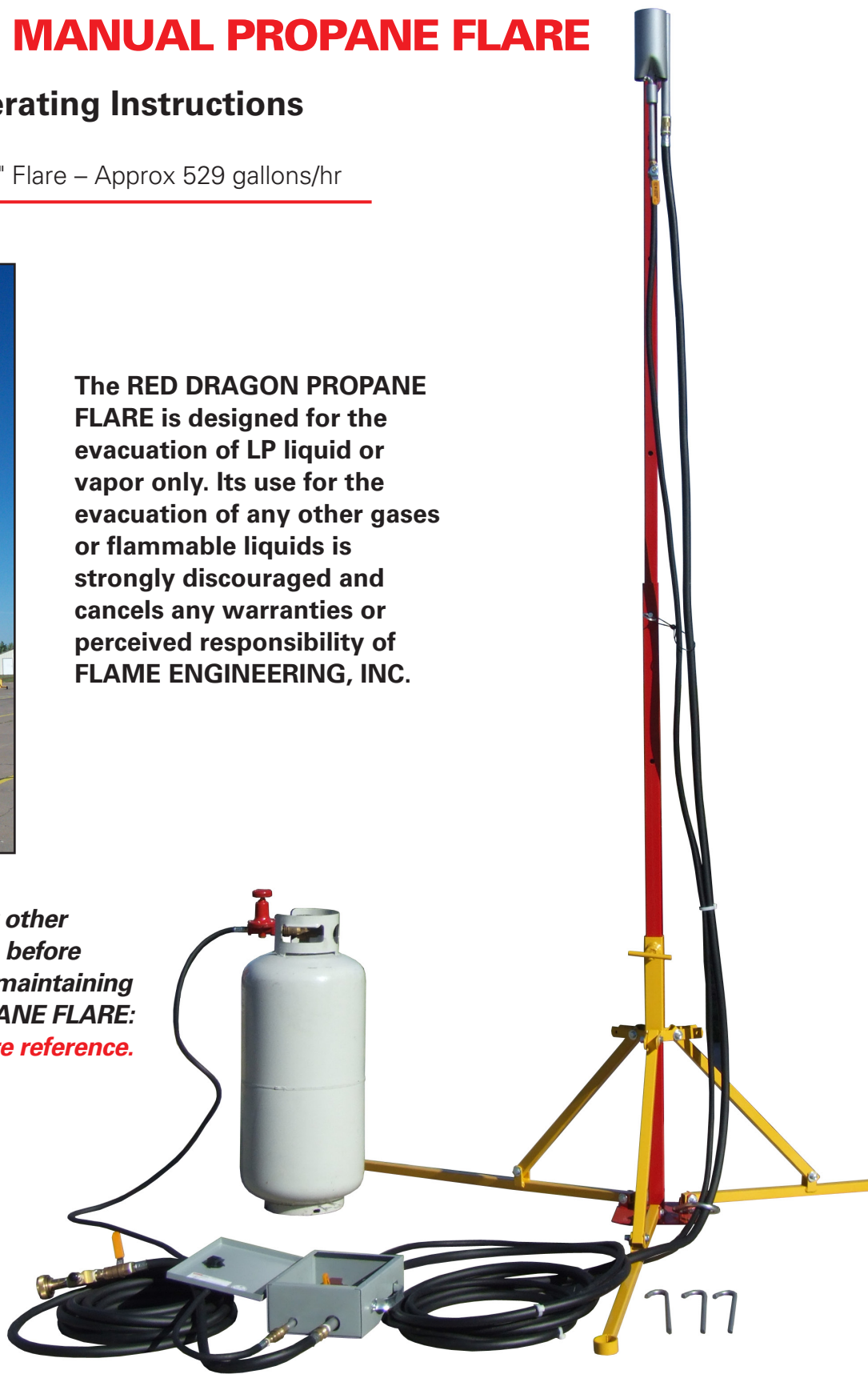

Failure to follow these instructions, local, state, national codes and other instructions provided with this flare equipment may result in serious injury or death.

TABLE OF CONTENTS:

Important Information and Safety Information	1
Other Required Equipment	2
Parts List	2
Component Photos and Descriptions.....	3
Assembly Instructions	4
Lighting Instructions	6
Shut Down Procedures	7
Disassembly Instructions.....	7
Trouble Shooting Tips & Other Flaring Rules	8

PLEASE READ BEFORE GETTING STARTED:

The purpose of the Red Dragon Manual Propane Flare is to provide an efficient process for the evacuation of propane liquid and or vapors from an LP container. It is important to remember a Red Dragon Manual Propane Flare will not completely empty the container. All safety rules, local ordinances, state and federal regulations are to be reviewed and permission granted by the appropriate authority before the flaring of LP cylinders in or near to a populated area.

All gas components used in the construction of the Red Dragon Propane Flare are either UL or CSA listed components.

NOTE: The Red Dragon Propane Flare is designed for the evacuation of LP gas liquids or gases only. The use of the flare for the evacuation of any other gases or flammable liquids is prohibited and voids any warranties expressed or implied.

Qualifications, Codes, Etc.

The testing, firing, and the service of this flare equipment requires training and knowledge of LP-Gas and LP-Gas appliances and should not be attempted by anyone who is not qualified. You must completely familiarize yourself with the flare, and its operation by reading and complying with the safety instructions, labels, owner's manual, etc. that is provided with each flare.

IMPORTANT SAFETY NOTE: The manual flare is not designed to be operated unattended.

OTHER REQUIRED EQUIPMENT NOT INCLUDED WITH THIS FLARE:

PILOT FUEL SOURCE:

A filled LP cylinder with a minimum of 5 gallon capacity (20lb cylinder) is required to provide the pilot torch fuel. A larger cylinder or several 5 gallon cylinders may be required for the complete flaring of a larger propane container.

SPARK LIGHTER OR SAFETY LIGHTER (*type used for grills and fireplaces*)

Required for the lighting of the pilot burner.



ADJUSTABLE WRENCH

Required for attaching the evacuation hoses to valve box, the flare head to the tower and the P.O.L. fitting to the pilot cylinder.

GLOVES AND EYE PROTECTION

Required for safe assembly & operation of the flare.

3 Cinder Blocks or 3 Sand Bags

Required for weighting down tripod if the flare is to be operated on pavement or soft soil where stakes are not sufficient.

PARTS LIST FOR PFM-16 LPS:

<i>Part No.</i>	<i>Description</i>
Flare Head/Flare Hose Assembly	
HP1/2x25S	1/2" 25' Rubber Hose
HP25	1/4" 25' Rubber Hose
V-14	1/4" Ball Valve
VT3-12PF-16	Pilot Torch
HN-6	Male Quick Connect
25' – 1/2" Evacuation Tank Hose Assembly	
HP1/2X25S	1/2" 25' Rubber Hose
H400	400 P.S.I. Pressure Relief Valve
F-3175	1 3/4" FE ACME X 1/2" MNPT
G-25	300 P.S.I. Liquid Pressure Gauge
V-12	1/2" Ball Valve
10' – 1/4" Pilot Cylinder Hose Assembly	
HP10	1/4" 10' Rubber Hose
567RC	0-60 PSI Regulator
P-3200W	Excess Flow POL
HN-5	Female Quick Connect
Valve Box	
32	8 X 10 Wiring Box
HN-5	Female Quick Connect
HN-6	Male Quick Connect
V-14	1/4" Ball Valve
V-12	1/2" Ball Valve
Miscellaneous Parts	
G-21	Flare Tower Retaining Pin
G-21-2	(3) Tripod Leg Retaining Pins
PFMBAG	Manual Flare Bag

COMPONENT PHOTOS & DESCRIPTIONS:

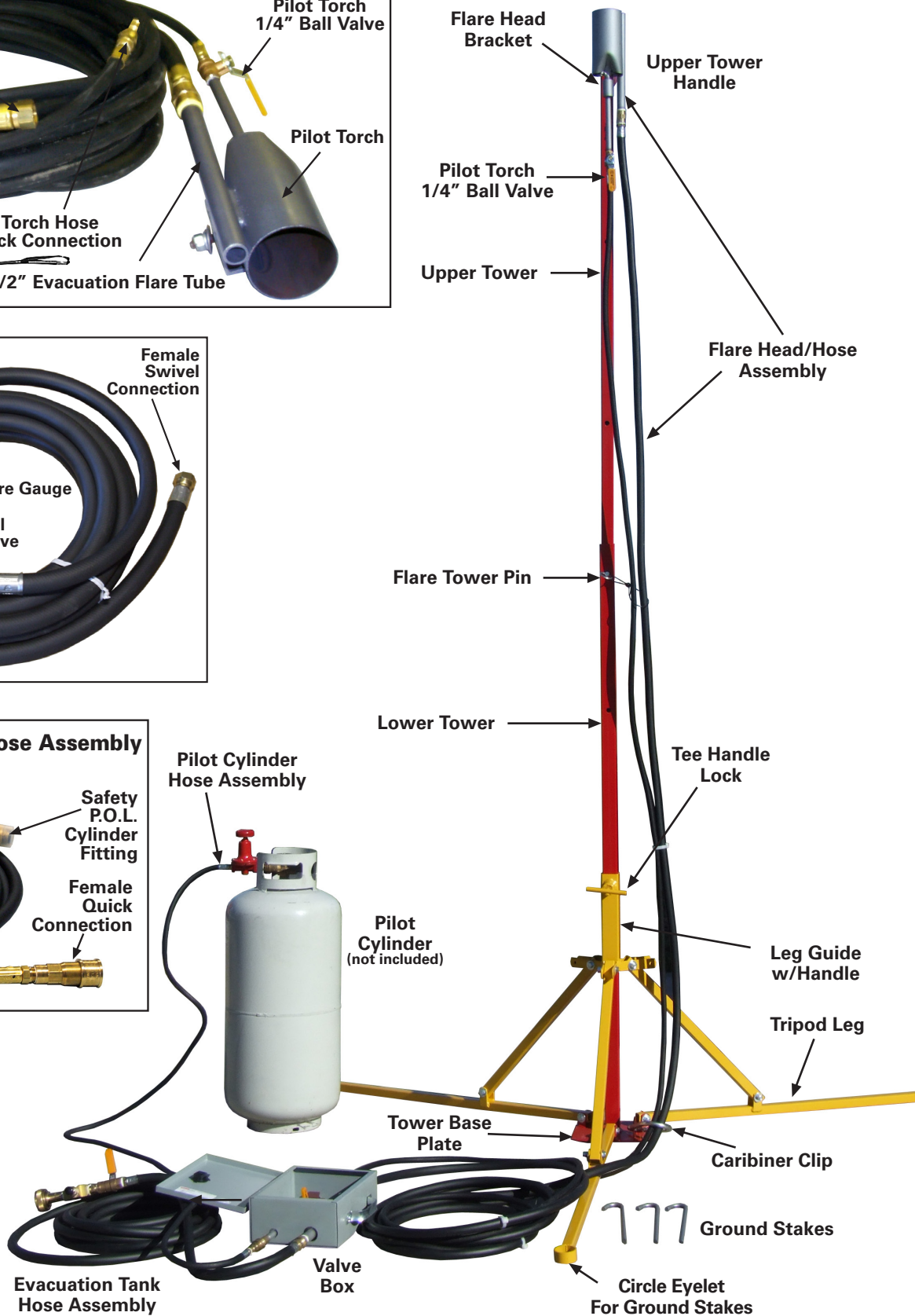
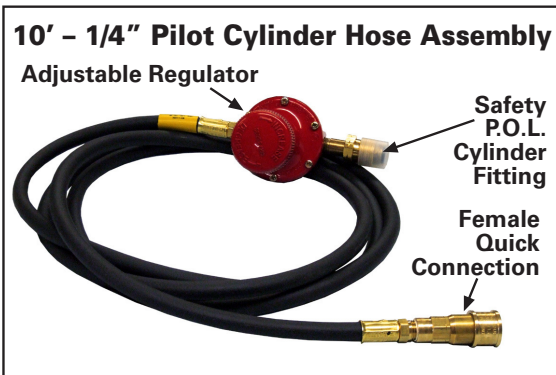
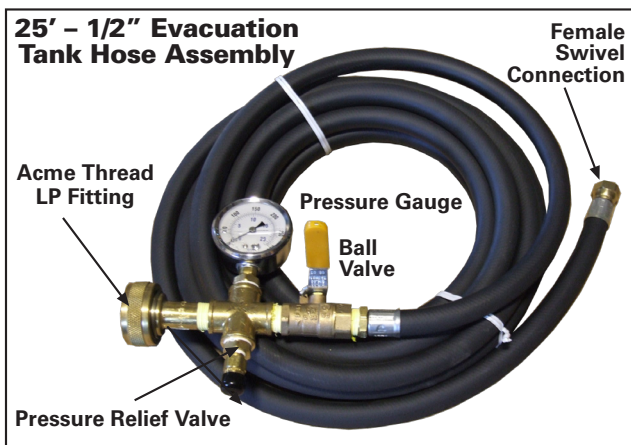
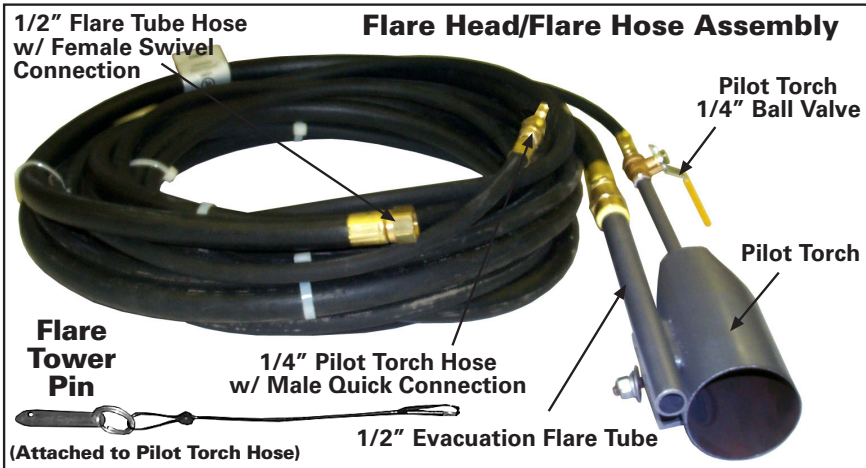

ASSEMBLY INSTRUCTIONS:

BEFORE OPERATING THE RED DRAGON PROPANE FLARE:

Make sure you have selected a safe area for placement and operation with approximately 40 foot radius and a minimum 50 feet of vertical clearance.

1. Stand the tower in an upright position on the tower base plate. Remove the three Leg Pins that are securing the Tripod Legs and pull the legs free of the storage brackets. (see photos A & B)

2. Pull the tee handle lock of the tripod leg guide. The leg guide will slide down until the tripod legs are at maximum extension. (see photos A, B & C)

3. Pull upward on the lower tower square tubing until the tee handle locks the tripod legs securely. (Test the flare tower position and confirm that the tripod legs cannot be folded. (see photos A & C)

IMPORTANT NOTE: The Eyelets at the end of each tripod leg are to hold the Ground Stakes if the tower is set up on dirt or grass. If using the flare tower on pavement, weight the tripod legs with sandbags or cinder blocks before operating. (see photos A & I)

4. Secure the Flare Head Hoses with the Caribiner Clip located on the Tower Base Plate. It will be necessary to leave plenty of hose between the Caribiner Clip and the Flare Head for when the tower is extended to its full height after the pilot torch is lit. **NOTE: Never operate flare without securing Flare Head Hoses in Caribiner Clip.** (see photos A, D & E)

5. Attach the Flare Head/Hose Assembly to the Flare Head Bracket located on the top of the tower in a vertical position and securely wrench tighten with the provided lockwasher and nut. (see photo F)

6. Next raise the Upper Tower and Flare Head to the pilot torch lighting position by doing the following:

a. Pull the Tee Handle Lock to unlock the Upper Tower square tubing. Push upward on the Red Upper Tower Handle until you see a pin hole in the Upper Tower tubing approximately 4 inches above the rim of the Lower Tower tubing.

b. While holding the upper tower at that height, use your free hand and pull up the Lower Tower square tubing until the Tee Handle Locks into position again. Let the upper tower down until it stops. Test the flare tower position again and confirm that the tripod legs are again locked and cannot be folded. (see photos G & H)

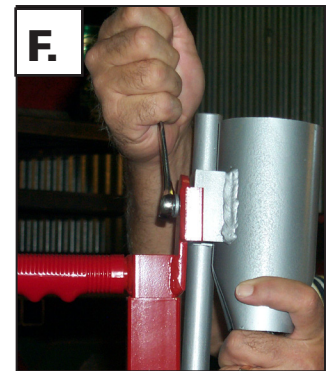
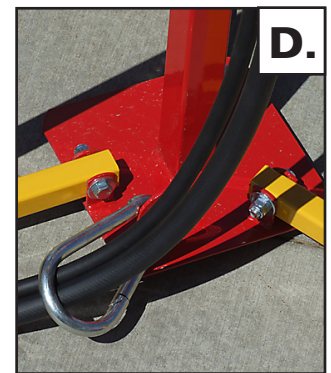
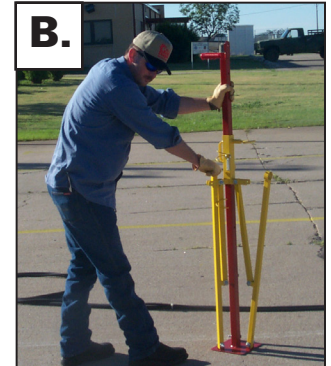
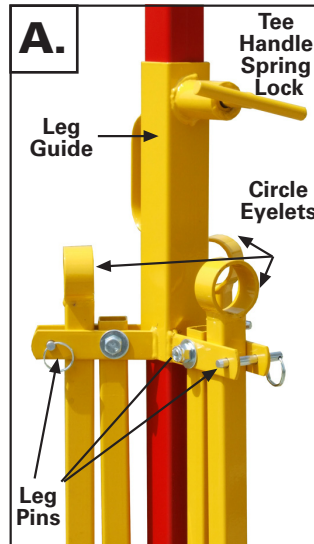

ASSEMBLY INSTRUCTIONS:



7. Arrange the tower so that the tripod leg with the hose bracket is pointing toward the tank being evacuated. Weight the tripod legs with cinder blocks or sand bags if the unit is to be operated on pavement. If the unit is to be operated on dirt or grass, stake each tripod leg down using the leg stakes included with the unit. (see photo I)

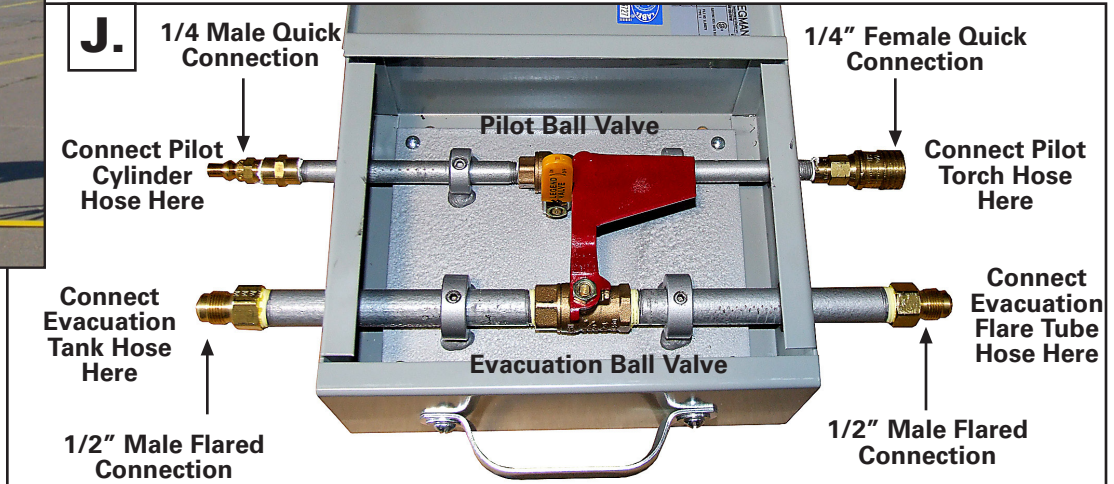

8. Attach the Flare Head Hoses to the Valve Box. They will both attach to the same side of the box. The 1/4" Pilot Torch Hose has a male quick connect fitting and will attach to the female quick connect fitting on the right side of the box. The 1/2" Evacuation Flare Tube Hose attaches to a male flared fitting so Teflon® or pipe thread sealant is NOT required. Wrench tighten but do not over tighten. (see photo J & K)

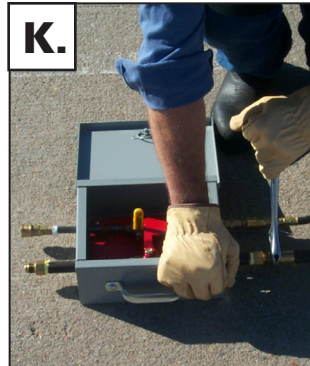

9. Attach the Female Quick Connection on the Pilot Cylinder Hose to the Male Quick Connection on the left side of the box. Attach the other end of the Pilot Cylinder Hose to the pilot cylinder using the P.O.L. fitting. **NOTE: Always use a separate pilot cylinder. Never use the tank being evacuated as the pilot source.** Wrench tighten but do not over tighten (remember this is a left hand thread fitting). (see photo J, L & M)



10. Attach the Female Swivel Connection on the Evacuation Tank Hose to the Male Flared Connection on the left side of the Valve Box. As mentioned before, Teflon® or pipe thread sealant is NOT required. (see photo J & L)

11. Attach the ACME Thread LP Fitting on the other end of the Evacuation Tank Hose to the LP Fuel container to be flared off. **ALWAYS WEAR GLOVES AND EYE PROTECTION WHEN ATTACHING THE EVACUATION TANK HOSE TO BULK LP TANKS.** (see photo N)

(NOTE: LP Containers without liquid withdrawal access require use of a P.O.L. fitting to attach to the fuel container being flared off.)

LIGHTING INSTRUCTIONS:

1. Slowly open the pilot cylinder valve 1/4 turn and test for leaks at all pilot fuel connections up to and inside the valve box using soapy water or commercial leak testing fluid. Turn off pilot cylinder and correct any leaks before continuing. **Repeat this step as many times as required to correct leaks.** (see photo O)



2. Open the valve on the on the fuel cylinder/tank to be evacuated 1/4 turn and test for leaks using soapy water or commercial leak testing fluid. Correct any leaks before proceeding. Slowly open the ball valve on the evacuation tank hose and test for leaks at all evacuation tank hose connections up to and inside the valve box using soapy water or commercial leak testing fluid. Turn off ball valve on the evacuation tank hose and correct any leaks before continuing. **Repeat this step as many times as required to correct leaks.**



3. With the pilot cylinder valve slightly opened, fully open the pilot valve inside the valve box. Check all connections from the box to the ball valve at the bottom of the Pipe Nippled attached to the Pilot Torch and correct any leaks before continuing. **Repeat this step as many times as required to correct leaks.** Proceed to the flare tower to light the pilot torch. (see photo P)



4. While wearing gloves, open the ball valve at the bottom of the pipe nipple attached to the pilot torch and light the pilot burner using a spark lighter or a safety lighter (type used for grills and fireplaces). (see photo Q)

5. Return to the pilot cylinder and fully open the cylinder valve.



6. Grasp the upper tower square tubing and extend the upper tower to full height and secure with the flare tower pin which is conveniently attached to the pilot torch hose. **Use extreme caution as the pilot torch is burning.** Check that all hoses remain in their proper hose brackets on the tower. (see photo R)



6. Slowly open the ball valve located on the end of the evacuation hose connected to the evacuation tank/cylinder. (see photo S)

7. Open the 1/2" evacuation ball valve inside the valve box. The pilot torch will safely light the fuel escaping from the flare tube at the top of the flare tower. (see photo T)

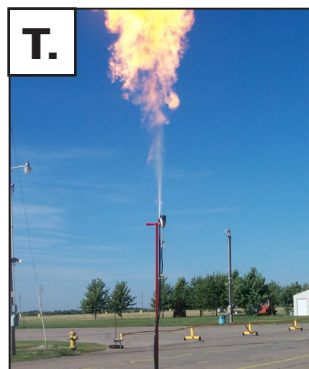

8. Return to the evacuation cylinder/tank and slowly continue to open the tank valve to the full open position. NOTE: The flame produced by the flaring process may be adjusted with partial closing of the evacuation valve inside the valve box or at the ball valve on the evacuation hose. (see photo U)



SHUT-DOWN PROCEDURE:

1. Close the valve on the cylinder/tank being evacuated.
2. Close the ball valve located on the end of the evacuation hose connected to the evacuated cylinder. Wait for all the fuel to burn out of this line.
2. Close the evacuation ball valve inside the valve box.
3. Close the pilot cylinder valve. Wait until the pilot flame is completely extinguished.
4. Close the pilot ball valve in the valve box and the ball valve at the bottom of the pilot torch.

DISASSEMBLY INSTRUCTIONS:

NOTE: Allow the flare head assembly ample time to cool before disassembly.

1. Disconnect the 1/2 inch evacuation hose from the cylinder being evacuated and the valve box. Visually inspect and clean the evacuation hose before coiling for storage.
2. Disconnect the pilot fuel hose from the pilot fuel cylinder and the valve box. Visually inspect and clean the pilot hose before coiling for storage.
3. Disconnect the flare head evacuation hose and flare head pilot hose from the valve box.
4. Inspect the valves and fittings for stress or leakage. Close and secure the lid to the valve box.
5. Remove flare tower pin and lower the flare tower to the storage position.
6. Examine the flare head for any damage. Remove the flare head from the flare tower **only after it is cool to the touch.**
7. Visually inspect and clean the flare head hoses before coiling for storage.
8. Fold the tripod legs into their storage position and pin.

TROUBLE SHOOTING TIPS AND OTHER FLARING RULES TO REMEMBER:

Lengthy Flare Jobs and the Pilot Fuel Source:

Always use a separate cylinder for the pilot source and have more than one pilot cylinder available for lengthy flaring situations. The pilot fuel source may become empty or drop below 18 P.S.I. and have to be replaced before the tank being evacuated is completely empty. When the pilot tank empties or drops below 18 P.S.I. the pilot will/may quit burning and raw LP gas could be released into the atmosphere. Follow the shut-down procedures and replace the pilot cylinder. Repeat lighting instructions to continue.

IMPORTANT NOTE: YOU SHOULD NOT USE THE SAME TANK YOU ARE EVACUATING FOR YOUR PILOT SOURCE.

Tank Freeze-Up and the Refrigeration Effect:

Tank freeze-up or pressure loss may occur when evacuating vapor withdrawal containers, especially while operating at outside temperatures below 50° F. Pilot containers may also be effected. Frost build up on the outside of the tanks, fittings and hoses are indicators of excessive refrigeration.

If the tank being evacuated is losing pressure, yet still contains fuel, you may be required to cease the flaring procedure for a few minutes to let the tank defrost. This effect can and will happen to the fuel tank being evacuated. Other side effects are the flare tube may accumulate frost (the frost in this case contains propane). In the right conditions this frost is flammable.

If the pilot tank is losing pressure or freezing up, replace it with a larger cylinder.

As the evacuation tank pressure drops, the speed of the process is reduced.

The fuel in the LP cylinder is being evacuated and burned at tank pressure. As the fuel is being consumed the pressure in the cylinder will drop. Outside temperature also has a direct effect on tank pressure.

Therefore, the flare will not produce 529 gallons per hour consumption up to the very last second. A fuel cylinder being evacuated on a 85 degree Fahrenheit day will flare faster than a fuel cylinder being evacuated on a 40 degree Fahrenheit day.

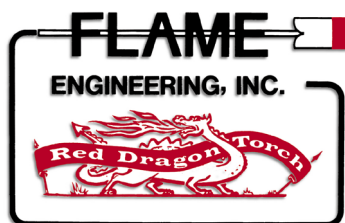

PFM-16 LPS Instruction Manual 7-2012