

RED DRAGON ELECTRONIC PROPANE FLARE

Assembly and Operating Instructions

For Models:

PF-16 LPS – 1/2" Flare – 48,300,000 BTU/hr Max

The RED DRAGON PROPANE FLARE is designed for the evacuation of LP liquid or vapor only. Its use for the evacuation of any other gases or flammable liquids is strongly discouraged and cancels any warranties or perceived responsibility of FLAME ENGINEERING, INC.



Read this manual and any other safety-related information before assembling, operating or maintaining your RED DRAGON PROPANE FLARE: Save this manual for future reference.

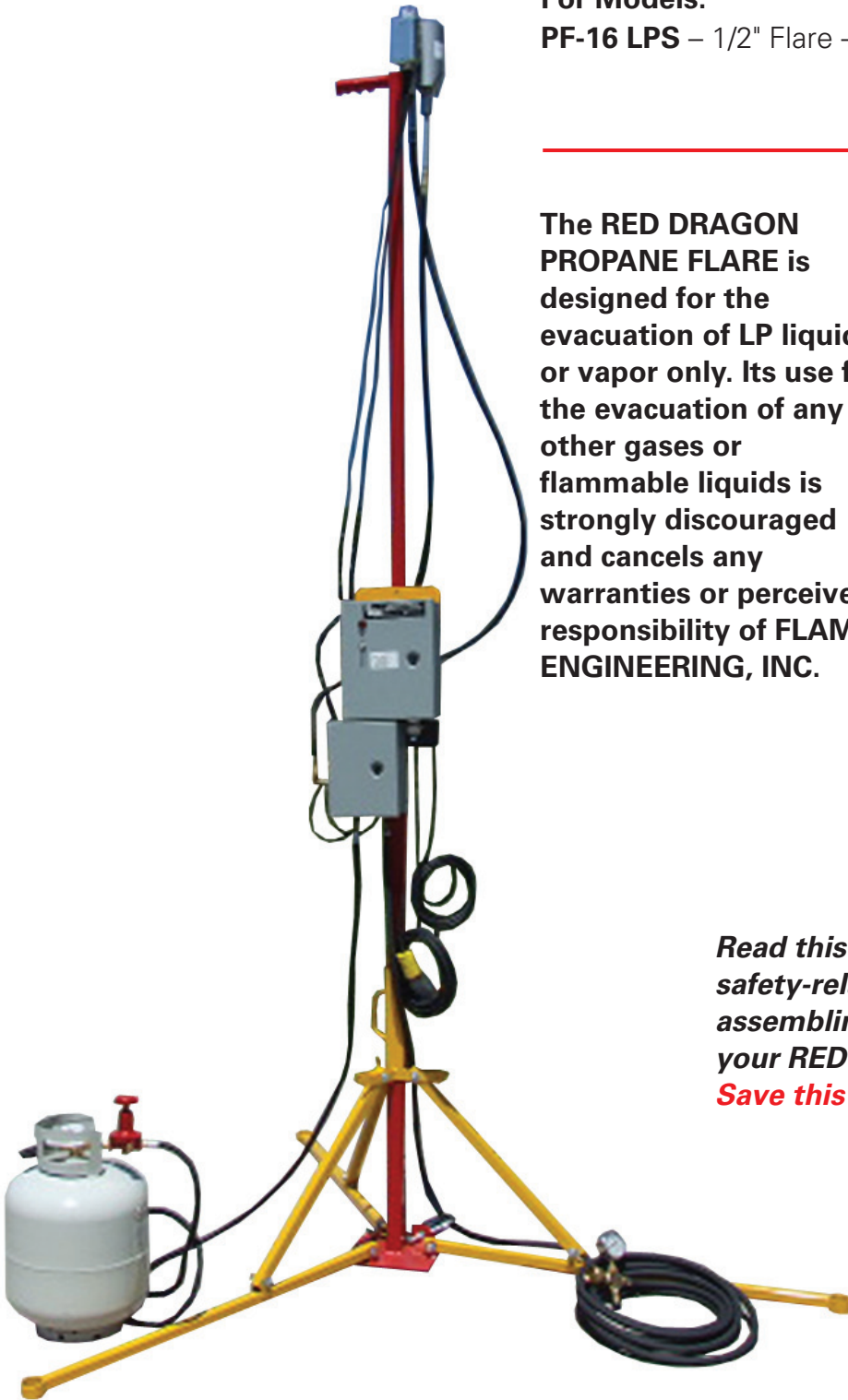

Failure to follow these instructions, local, state, national codes and other instructions provided with this flare equipment may result in serious injury or death.

TABLE OF CONTENTS:

Important Information and Safety Information	1
Other Required Equipment	1
Component Photos and Descriptions.....	2
Assembly Instructions	3
Lighting Instructions	5
Shut Down Procedures	5
Trouble Shooting Tips & Other Flaring Rules	6
Parts List	8

PLEASE READ BEFORE GETTING STARTED:

The purpose of the Red Dragon Electronic Propane Flare is to provide an efficient process for the evacuation of propane liquid and or vapors from an LP container. It is important to remember a Red Dragon Propane Flare will not completely empty the container. All safety rules, local ordinances, state and federal regulations are to be reviewed and permission granted by the appropriate authority before the flaring of LP cylinders in or near to a populated area.

All gas components used in the construction of the Red Dragon Propane Flare are either UL or CSA listed components.

NOTE: The Red Dragon Propane Flare is designed for the evacuation of LP gas liquids or gases only. The use of the flare for the evacuation of any other gases or flammable liquids is prohibited and voids any warranties expressed or implied.

Qualifications, Codes, Etc.

The testing, firing, and the service of this flare equipment requires training and knowledge of LP-Gas and LP-Gas appliances and should not be attempted by anyone who is not qualified. You must completely familiarize yourself with the flare, and its operation by reading and complying with the safety instructions, labels, owner's manual, etc. that is provided with each flare.

IMPORTANT SAFETY NOTE: The manual flare is not designed to be operated unattended.

OTHER REQUIRED EQUIPMENT NOT INCLUDED WITH THIS FLARE:

D=CH: I 9 @GCI F79

A filled LP cylinder with a minimum of 5 gallon capacity (20lb cylinder) is required to provide the pilot torch fuel. A larger cylinder or several 5 gallon cylinders may be required for the complete flaring of a larger propane container.

58>I GH56 @`K F9B7<

Required for attaching the evacuation hoses to valve box, the flare head to the tower and the P.O.L. fitting to the pilot cylinder.

; @CJ9G`5 B8 `9M9`DFCH97 H=CB

Required for safe assembly & operation of the flare.

' `7 Ya Ybh6 `cW`g`cf" `GUbX`6 U` g

Required for weighting down tripod if the flare is to be operated on pavement or soft soil where stakes are not sufficient.

COMPONENT PHOTOS & DESCRIPTIONS:

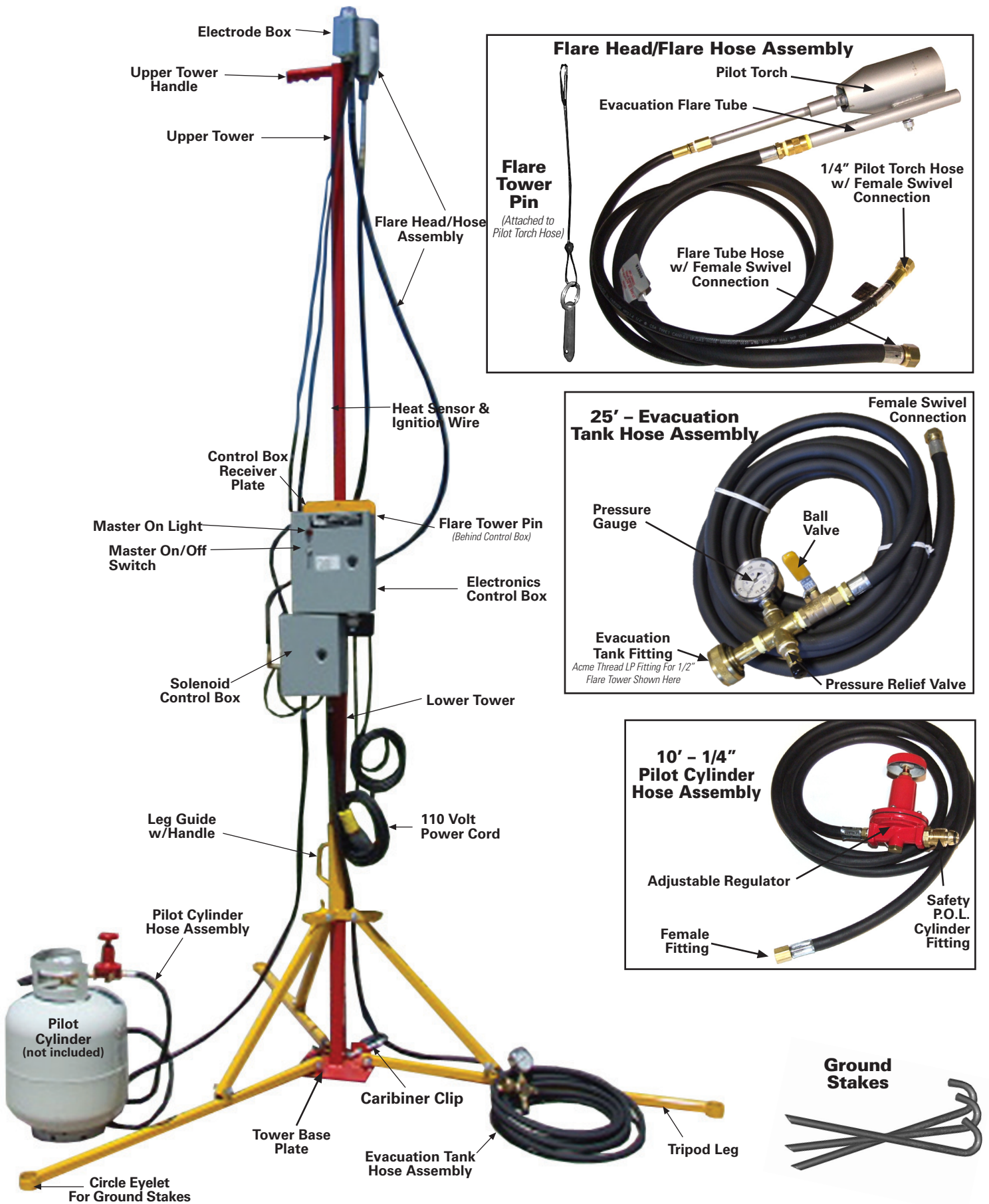

ASSEMBLY INSTRUCTIONS:

BEFORE OPERATING THE RED DRAGON PROPANE FLARE:

Make sure you have selected a safe area for placement and operation with approximately 40 foot radius and a minimum 50 feet of vertical clearance.

1. Stand the tower in an upright position on the tower base plate. Remove the three Leg Pins that are securing the Tripod Legs and pull the legs free of the storage brackets. (see photos A & B)

2. Pull the tee handle lock of the tripod leg guide. The leg guide will slide down until the tripod legs are at maximum extension. (see photos A ,B & C)

3. Pull upward on the lower tower square tubing until the tee handle locks the tripod legs securely. (Test the flare tower position and confirm that the tripod legs cannot be folded. (see photos A & C)

IMPORTANT NOTE: The Eyelets at the end of each tripod leg are to hold the Ground Stakes if the tower is set up on dirt or grass. If using the flare tower on pavement, weight the tripod legs with sandbags or cement blocks before operating.

4. Assemble the electrode box, pilot torch and evacuation flare tube to the receiver bracket on the top of the upper tower using a lock-washer and hex nut. (See Photo D and Diagram 1)

5. Attach the control box to the control box receiver plate at the top of the lower tower section using the provided wing nuts. (See Photo E)

6. Run the pilot hose and evacuation fuel hose from the torch through the hose secure ring on the upper tower collar and attach them to the appropriate fittings on the left side of the solenoid (bottom) control box. The main evacuation line will connect to the top fitting and the pilot torch line will connect to the bottom fitting. These are flared fittings – no need for thread sealant. (See Photo F)

7. Grasp the upper tower square tubing or handle and extend the upper tower to full height and secure with the flare tower pin which is conveniently attached to the pilot torch hose. Check that all hoses remain in their proper hose brackets on the tower.

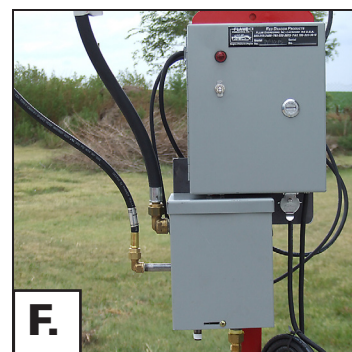
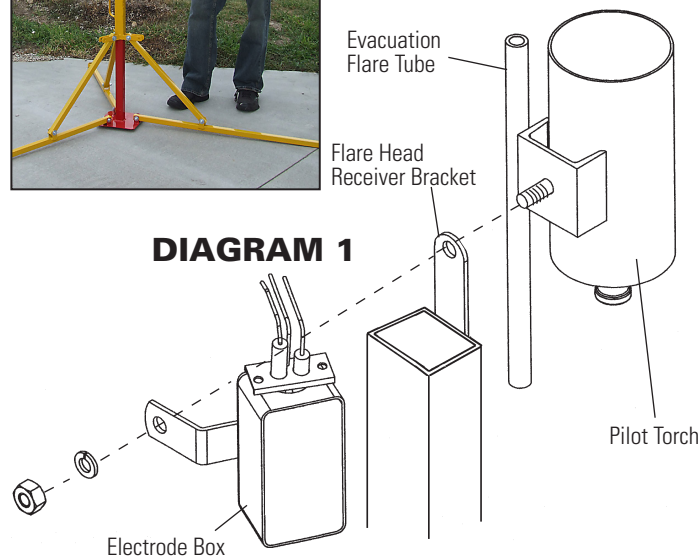
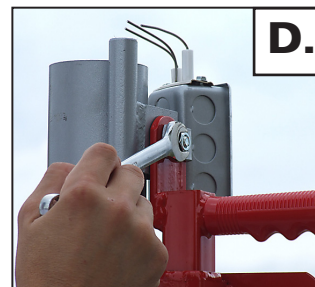
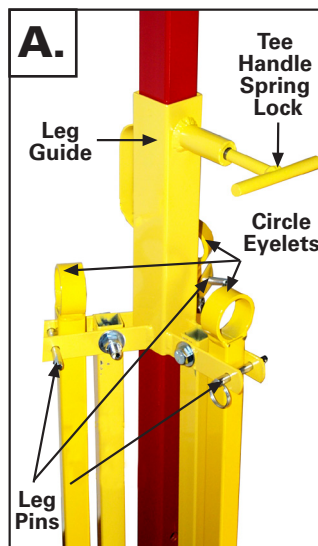

ASSEMBLY INSTRUCTIONS:

8. Arrange the tower so that the tripod leg with the hose bracket is pointing toward the tank being evacuated. Weight the tripod legs with cinder blocks or sand bags if the unit is to be operated on pavement. If the unit is to be operated on dirt or grass, stake each tripod leg down using the leg stakes included with the unit.

9. Attach the Female Swivel Connection on the Pilot Cylinder Hose to the Male Connection on the bottom left male fitting on the bottom of the solenoid control box. Attach the other end of the Pilot Cylinder Hose to the pilot cylinder using the P.O.L. fitting. **NOTE: Always use a separate pilot cylinder. Never use the tank being evacuated as the pilot source.** Wrench tighten but do not over tighten (remember this is a left hand thread fitting).(see photo G)

10. Attach the Female Swivel Connection on the Evacuation Tank Hose to the Male Flared Connection on the bottom right of the Solenoid Control Box. As mentioned before, Teflon® or pipe thread sealant is NOT required. (see photo G)

Note: Use the caribiner clip to keep the evacuation hose in an orderly manner. (See Photo H)

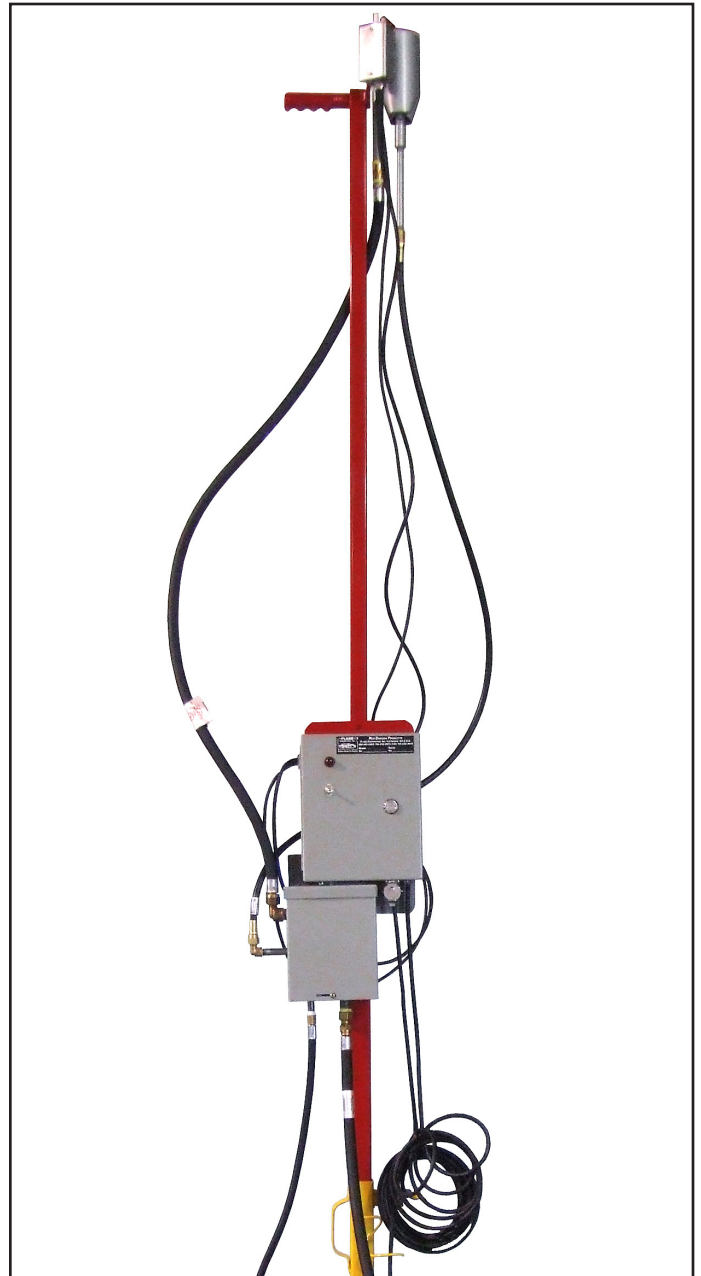
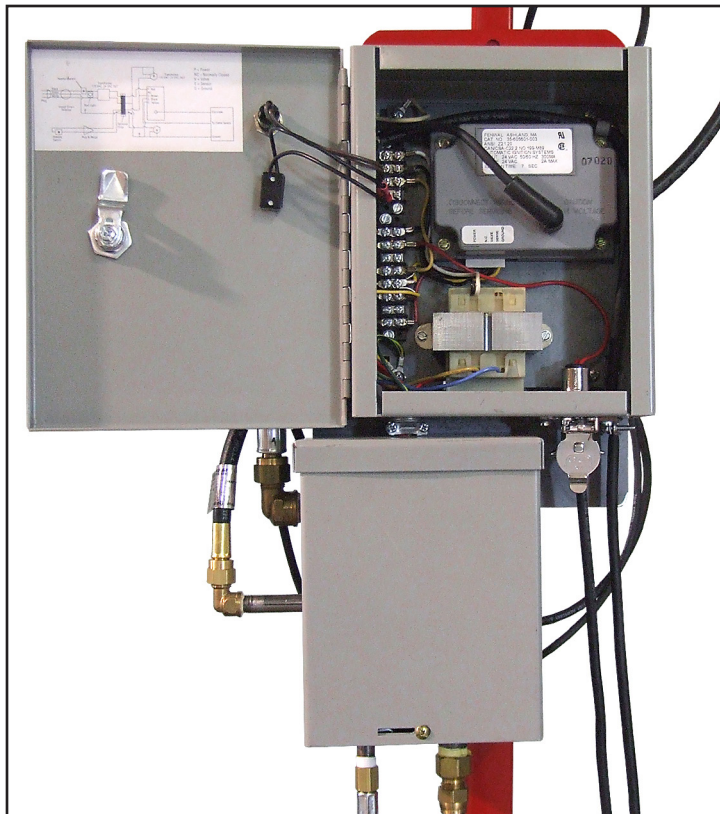
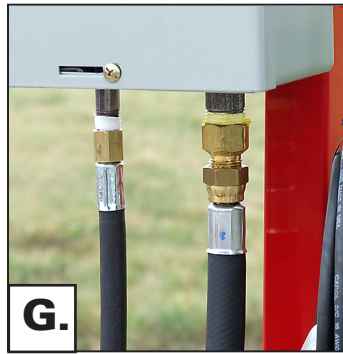

RED DRAGON PROPANE FLARE OPERATING INSTRUCTIONS

**BEFORE OPERATING THE RED DRAGON PROPANE FLARE:
Make sure you have selected a safe area for placement and operation with approximately 40 foot radius and a minimum 50 feet of vertical clearance.**

LIGHTING PROCEDURES

Before Starting, Make sure the "Main" switch and the "Remote" switch are in the "OFF" position.

1. Attach pilot hose to an LPG fuel supply with at least five gallon capacity.
2. Attach the main evacuation line to the tank being evacuated. This connection will be either a P.O.L fitting or a commercial tank connection, depending on the model.
3. Slightly open each tank, one at a time, and test for leaks at all connections to the Solenoid Control Box using soapy water or commercial leak testing fluid. Turn off tanks and correct any leaks before continuing. Repeat this step if you have to correct leaks until none are found.
4. Make certain that the main and remote switches are in the "OFF" position. Slowly open each tank valve fully. Connect electrical power cord to a 110 volt A.C. power source.
5. After making certain the remote switch is in the "OFF" position, move the main switch to the "ON" position. The RED indicator light will come on. The pilot torch should now automatically light.

NOTE: It is possible you will hear the buzzing sound of the electrical spark attempting to light the pilot burner. The ignition system will cycle in seven seconds. The ignition system will attempt to re-light after a 7 second delay. A third ignition will be attempted. Failure to establish a pilot results in the unit locking out.

Should the pilot not achieve ignition, turn the main switch "OFF", wait 30 seconds and start again. It may be necessary to repeat this procedure several times to purge sufficient fuel through the pilot fuel lines.

Once the pilot is burning, the system will continue to monitor itself. If the pilot torch goes out, an automatic relight is attempted. If reignition does not occur within 10 seconds, the system will automatically shut down and the operator should start again at step 4 in these instructions.

6. After pilot is ignited, move the remote switch to the "ON" position to start evacuation of the main tank. Leak test hose connections from torch and flare tube to the solenoid control box using soapy water or commercial leak detector.

SHUT DOWN PROCEDURES

1. Turn the valve off on the tank being evacuated and allow all LP-Gas to escape from the fuel line.
2. Turn the remote switch to "OFF".
3. Close the pilot tank valve.
4. After pilot has burned out, turn main switch to "OFF".
5. Disconnect the unit from the power supply and disconnect hoses from both tanks.

RED DRAGON PROPANE FLARE OPERATING INSTRUCTIONS

CARE AND MAINTENANCE

1. Check all screws on the terminal strips in the electronic control box for tightness before and after each use. Tighten if needed.
2. Store the unit in a dry place to protect the burners and ignition system components.
3. Always leak check all connections before each use and correct as necessary before lighting. DO NOT operate the unit if any leaks are present.

TROUBLE SHOOTING TIPS

Ignition and Heat Sensor:

The ignition and heat sensor electrodes can be sensitive. If unit is not lighting or staying lit, make sure the electrodes have a 90° angle and that the gap between the ignitor and the ground is 1/4". The ignitor and ignitor ground wire should be over the pilot torch bell an 1/8" - 1/4" and the heat sensor wire should just barely cross the edge as shown below.

The flare solenoid will only activate when pilot flame is sensed. If flare solenoid fails to activate double check the position of the heat sensor wire and make sure it is positioned as shown below.

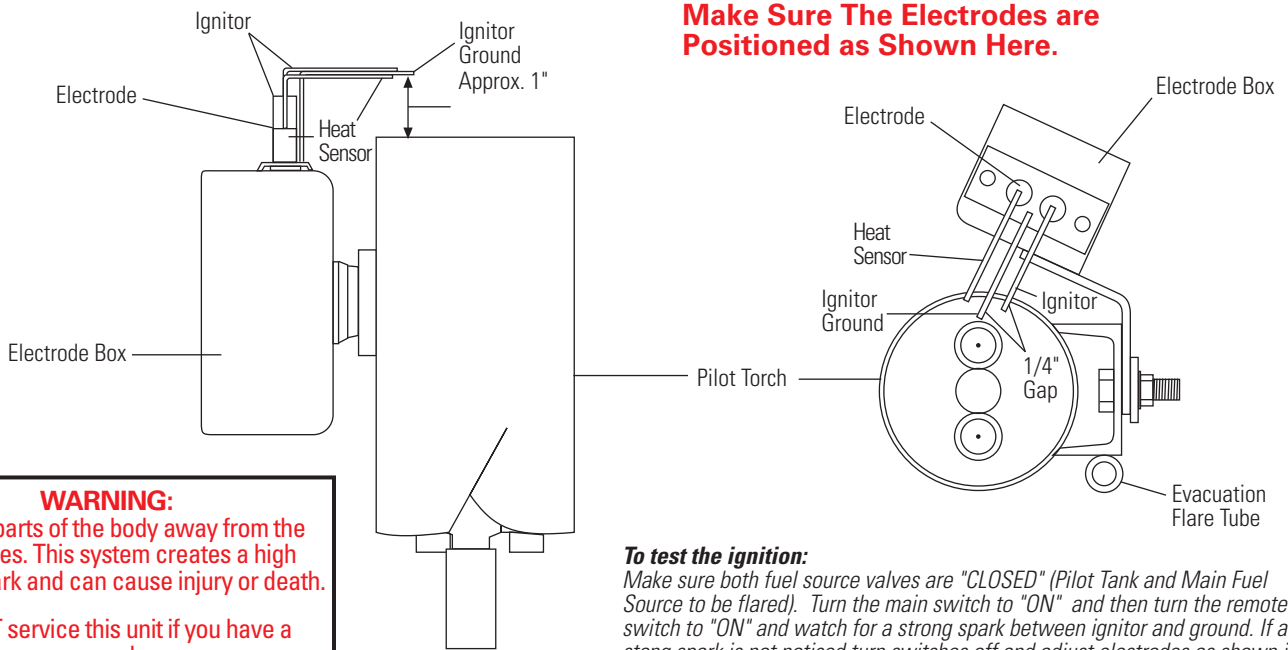

WARNING:
Keep all parts of the body away from the electrodes. This system creates a high voltage spark and can cause injury or death.
DO NOT service this unit if you have a pacemaker.

To test the ignition:
Make sure both fuel source valves are "CLOSED" (Pilot Tank and Main Fuel Source to be flared). Turn the main switch to "ON" and then turn the remote switch to "ON" and watch for a strong spark between ignitor and ground. If a strong spark is not noticed turn switches off and adjust electrodes as shown in these diagrams. Keep hands and head a safe distance away from the flare head as there may be a small amount of fuel left in the lines.

Flaring in the Wind:

The Red Dragon Flare can operate in winds up to 25 mph. It may be necessary to rotate the flare so the electrodes and heat sensor are situated in the pilot flame but not exposed to the fuel coming from the evacuation flare tube.

Flaring in the Rain:

Flaring may not be possible in rainy conditions. Rain may extinguish the pilot or cool the heat sensor enough to where it will shut-down the flare solenoid.

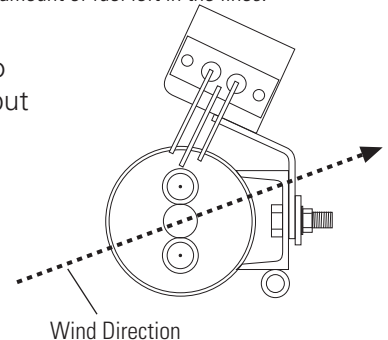

RED DRAGON PROPANE FLARE OPERATING INSTRUCTIONS

REPLACEMENT PARTS LIST

DESCRIPTION.....Part No.

FLARE HEAD:

Pilot torch/flare tube assembly:

For Model PF-16 LPS 1/2" Flare..... VT 3-12 PF-16

Electrode assembly:

Electrode (Ignitor and Heat Sensor).....26
 Electrode Box and Cover.....36
 Hi Temp Wire Insulator.....26-2

HOSES:

1/4" Pilot Hoses:

65" Hose – Solenoid Control Box to Pilot Torch.....HP65T
 10' Hose – Pilot fuel source to Solenoid Control Box..... HP10C

Flare Hoses:

Hose From Solenoid Control Box to Flare Tube

For Model PF-16 LPS 1/2" Flare.....60" – HP1/2-5TS

25' Hose From Main Tank to Solenoid Control Box

For Model PF-16 LPS 1/2" Flare.....25' – HP1/2X25S

REGULATOR:

25 lb. Preset Regulator For Pilot Tank.....567 RC

TANK CONNECTIONS:

Safety P.O.L. For Pilot Tank Connection.....P-3200 W
 Commercial Tank Connector for 1/2" Flare Line.....F-3175

PRESSURE GAUGE AND PRESSURE RELIEF VALVE:

300 lb. Pressure Gauge for Main Tank.....G-25
 400 P.S.I. Pressure Relief Valve For Evacuation Hose.....H400

CONTROL BOXES AND INDIVIDUAL COMPONENTS:

Complete Controls: Electronics Control Box, Solenoid Control Box, Electrode and Remote Switch

For PF-16 LPS 1/2" Flare.....CS603

Electronic Control Box (Top Box) & Electrode Components:

Main ON/OFF Toggle Switch.....M 3008
 Main ON Indicator Light.....330
 Ignition Control Box.....Model 24
 Wiring Harness For Ignition Control Box.....Model 24W
 Transformer (output is 24 V / 60 VA).....28
 Terminal Connection Strips.....29 & 29-8
 Remote Switch with 20' connection wire.....PFRS
 10' 110 Volt A.C. Power Cord.....PFPW
 10' Sensor Cable.....PFSW
 10' Ignition wire.....PFIW
 Electrode (Ignitor and Heat Sensor).....26
 Electrode Box.....36
 Hi Temp Wire Insulator.....26-2

Solenoid Control Box Components (Bottom Box):

24 Volt A.C. normally closed solenoid valves:
 1/4" Solenoid for pilot on all Solenoid Control Boxes.....S-124
 1/2" Solenoid for PF-16 LPS 1/2" Flare.....S-126

Miscellaneous Parts:

Flare Tower Retaining Pin.....G-21
 Tripod Leg Retaining Pins.....G-21-2 (3)
 Control Box Receiver Plate.....PF-TA

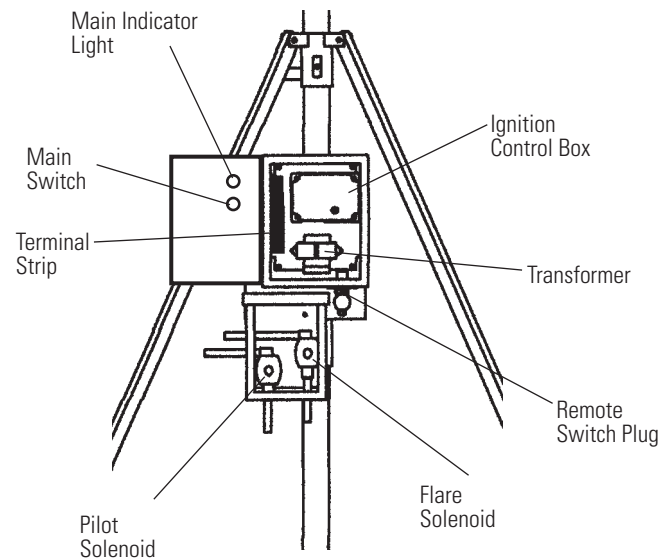
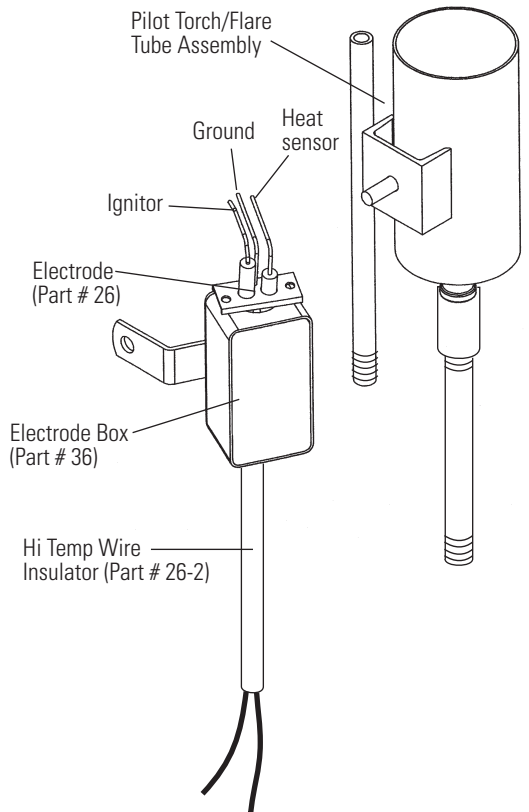



PFLPS Instruction Manual 7-2012