

DODGE/CHRYSLER Charger, Magnum, 300C and Challenger

Hemi Cars

Supercharger System Installation Instructions

**2005-2010 Model Years
50 State Smog Legal per CARB EO# D-213-31**

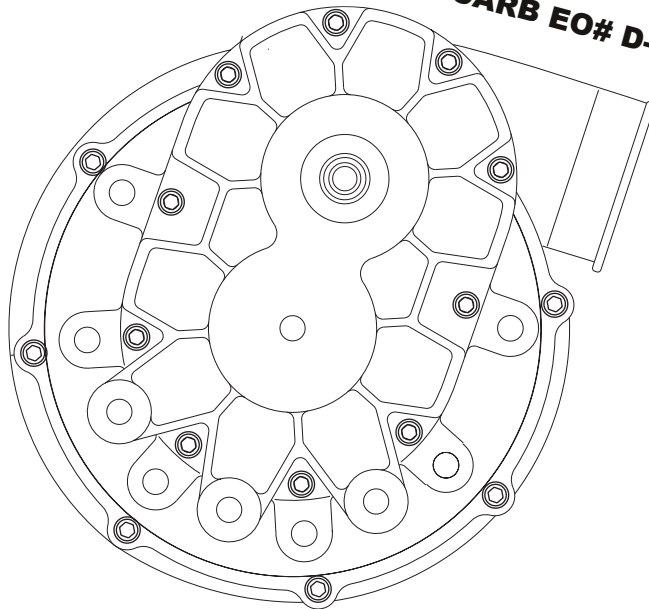

ENGINEERING, INC.

1650 PACIFIC AVENUE • CHANNEL ISLANDS, CA 93033-9901 • (805) 247-0226
FAX (805) 247-0669 • www.vortechsuperchargers.com

FOREWORD

This manual provides information on the installation, maintenance and service of the Vortech supercharger kit expressly designed for this vehicle. All information, illustrations and specifications contained herein are based on the latest product information available at the time of this publication. Changes to the manual may be made at any time without notice. Contact Vortech Engineering for any additional information regarding this kit and any of these modifications at (805) 247-0226 8:00am-4:30pm PST.

Take note of the following before proceeding:



1. Proper installation of this supercharger kit requires general automotive mechanic knowledge and experience. Please browse through each step of this instruction manual prior to beginning the installation to determine if you should refer the job to a professional installer/technician. Please contact your dealer or Vortech Engineering for possible installers in your area.
2. **This product was designed for use on stock (*un-modified, OEM*) vehicles.** The PCM (*computer*), engine, transmission, drive axle ratios and tire O.D. must be stock. If the vehicle or engine has been modified in any way, check with Vortech prior to installation and use of this product.
3. Use only premium grade fuel with a minimum of 91 octane (*R+M/2*).
4. Always listen for any sign of detonation (*knocking/pinging*) and discontinue hard use (*no boost*) until the problem is resolved.
5. Vortech is not responsible for any clutch, transmission, drive-line or engine damage.

Exclusions from Vortech warranty coverage considerations include, but not limited to:

1. Neglect, abuse, lack of maintenance, abnormal operation or improper installation.
2. Continued operation with an impaired vehicle or sub-system.
3. The combined use of Vortech components with other modifications such as, but not limited to, exhaust headers, aftermarket camshafts, nitrous oxide, third party PCM programming or other such changes.

© 2012 VORTECH ENGINEERING, INC.

All rights reserved. No part of this publication may be reproduced, transmitted, transcribed, or translated into another language in any form, by any means without written permission of Vortech Engineering, Inc.

TABLE OF CONTENTS

FOREWORD	ii
TABLE OF CONTENTS.....	iii
IMPORTANT NOTES	iv
TOOL & SUPPLY REQUIREMENTS.....	v
PARTS LISTS.....	vi
1. PREPARATION AND REMOVAL	1
2. HARMONIC DAMPER DOWEL PIN INSTALLATION	3
3. FUEL INJECTOR REPLACEMENT	4
4. SUPERCHARGER MOUNTING PLATE INSTALLATION	5
5. SUPERCHARGER INSTALLATION	8
6. AIR INLET INSTALLATION	9
7. CHARGE AIR COOLER (CAC) CORE INSTALLATION	11
8. RESERVOIR AND WATER PUMP ASSEMBLY AND INSTALLATION	12
9. CHARGE AIR COOLER RADIATOR INSTALLATION	13
10. SUPERCHARGER DISCHARGE ASSEMBLY INSTALLATION	15
11. FUEL PUMP VOLTAGE BOOSTER INSTALLATION (SOME MODELS)	17
12. REFLASH COMPUTER	21
13. FINAL ASSEMBLY AND CHECKING	22

OFF-HIGHWAY USE

When driving vehicle on non-public roads (off-road applications such as racing/high RPM) Vortech strongly recommends reducing the factory spark plug gap down to .032”.

COPYRIGHT NOTICE

This product is protected by state common law, copyright and/or patent. All legal rights therein are reserved. The design, layout, dimensions, geometry and engineering features shown in this product are the exclusive property of Vortech Engineering, INC.. This product may not be copied or duplicated in whole or part, abstractly or fundamentally, intentionally or fortuitously, nor shall any design, dimension, or other information be incorporated into any product or apparatus without prior written consent of Vortech Engineering, INC..

ATTENTION

BEFORE STARTING INSTALLATION, PLEASE NOTE THE FOLLOWING:

DiabloSport releases new software versions almost daily. These updates add vehicle support, features, and more. **ALWAYS** update your tuner before installing it on your vehicle.

Wi-Fi Updates

To get the latest updates for your i3 via a Wi-Fi connection, go to the device's settings menu. There you will have the ability to find your wireless network, enter the password, and search for any available software updates.

"Note: i3's Wi-Fi will not connect to networks that require a web browser for sign in (i.e. hotel)."

Windows Updates

When you plug the i3 into a Windows PC, it creates a drive in "My Computer" called i3. Open the drive, click into the "Updater" folder, then the "Windows" folder, where you can find the inTune Updater Utility. Follow the prompts to begin the update process.

Mac OSX Updates

When you plug the i3 into a Mac, it will create a drive called i3 in the Finder window. Open the drive, click into the "Updater" folder, then the "Mac" folder where you can find the inTune Updater Utility. Follow the prompts to begin the update process.

"Note: requires Java installation on OS X."



If you require further assistance in updating your tuner, please contact DiabloSport.

Dodge/Chrysler Hemi Cars Installation Instructions

Congratulations on selecting the best performing and best backed automotive supercharger available today... the VORTECH® Supercharger!

Before beginning this installation, please read through this entire instruction booklet and the Street Supercharger System Owner's Manual which includes the Automotive Limited Warranties Program and the Warranty Registration form.

Vortech supercharger systems are performance improving devices. In most cases, increases in torque of 30-35% and horsepower of 35-45% can be expected with the boost levels specified by Vortech Engineering. This product is intended for use on healthy, well maintained engines. Installation on a worn-out or damaged engine is not recommended and may result in failure of the engine as well as the supercharger. **Vortech Engineering is not responsible for engine damage.**

Installation on new vehicles will not harm or adversely affect the break-in period so long as factory break-in procedures are followed.

For best performance and continued durability, please take note of the following key points:

1. Use only premium grade fuel 91 octane or higher (R+M/2).
2. The engine must have stock compression ratio.
3. If the engine has been modified in any way, check with Vortech prior to using this product.
4. Always listen for any sign of detonation (pinging) and discontinue hard use (no boost) until problem is resolved.
5. Before beginning installation, replace all spark plugs that are older than 1 year or 10,000 miles with original heat range plugs as specified by the manufacturer and reset timing to factory specifications (follow the procedures indicated within the factory repair manual and/or as indicated on the factory underhood emissions tag). **Do not use platinum spark plugs unless they are original equipment.** Change spark plugs every at least 15,000 miles and spark plug wires at least every 50,000 miles.

TOOL & SUPPLY REQUIREMENTS:

- Factory Repair Manual
- 3/8" Socket and Drive Set: SAE & Metric
- 1/2" Socket and Drive Set: SAE & Metric
- Adjustable Wrench
- Open End Wrenches: 3/8", 7/16", 1/2", 9/16"
- Flat #2 Screwdriver
- Phillips #2 Screwdriver
- Drill Motor
- 1/8", 3/16", 1/4", 27/64" Drill Bits
- 3/16" Allen Wrench
- Wire Strippers and Crimpers
- Utility Knife

If your vehicle has in excess of 15,000 miles since its last spark plug change, then you will also need:

- Spark Plug Socket
- NEW Spark Plugs

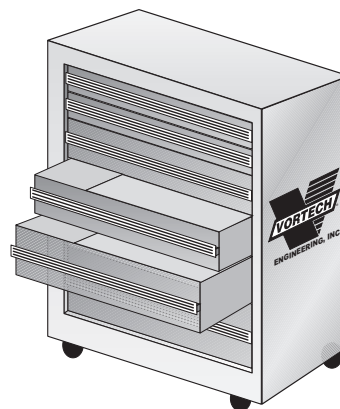



ENGINEERING, INC.

2005-2008 Hemi 5.7L Car Supercharger Kit

Part No. 4CL218-010L

PARTS LIST

IMPORTANT: Before beginning installation, verify that all parts are included in the kit. Report any shortages or damaged parts immediately.

PART NO.	DESCRIPTION	QTY	PART NO.	DESCRIPTION	QTY
008118	DECAL, VINYL, VORTECH	2	4GR116-300	IDLER ASSY, 20MM BELT	1
008130	LICENSE PLATE FRAME, VORTECH	1	4CL116-350	IDLER ASSY, 20 MM, SRT8 3.5	1
008341	POWERCOOLER DECAL	1	7J500-002	1/2" LOCK WASHER	1
008447	S/C STREET PACKAGE ASSEMBLY	1	4FD017-011	PILOT, 6205 BRG 1/2" SCREW	1
009035	LUBE ASSY, 3-PACK	1	4HS017-041	SPACER, LOWER S/C PLT S2000	2
2A046-106	BELT PREMIUM 104.5"	1	4NZ030-041	BRG HSG, 350Z	1
2F329-030	S/C ASSY, V3 CCW SI 5.7L CAR	1	7A250-075	1/4-20 X .75 SHCS	6
4GR033-034	PULLEY, SC, C5, 20MM, 34T	1	7A312-152	5/16-18 X 1.5 SHCS, ZN PLT	4
4CL020-010	INSTRUCTION MANUAL, HEMI	1	7A375-100	3/8-16X1 G5 HXHD PLT	4
4CL110-030	FUEL ASSY, 5.7L HEMI CAR	1	7A375-225	3/8-16 X 2 1/4" G8 HX HD	1
4CL010-030	MAP SENSOR BLOCK, 07 CHARGER	1	7B375-075	3/8-24 X 3/4" GR8 HXHD BOLT	1
5A002-017	MAP SENSOR, 07 CHARGER SC	1	7B375-150	3/8-24X 1-1/2 GR8 HX	1
7C010-052	10-24 X 1/2 BUTTN HEAD CRWW	2	7C012-100	12MM X 100MM X 1.75 HXHD BOLT	1
7P062-187	1/16NPT X 3/16 HOSE BARB	2	7C080-066	M8 X 1.25 X 65 HXHD CL10.9	1
7P250-045	1/4 MALE NPT X 3/8 MALE BARB	1	7C080-090	M8 X 1.25 X 90 HXHD CL10.9	7
7P375-113	PCV VALVE, VIPER, 3/8"-1/2" HOSE 90°	1	7C080-100	M8 X 1.25 X 100 HXHD ZN PLT	3
7P500-003	1/2"-3/8" REDUCER BARB UNION	1	7C080-120	BOLT, 8MM X 120MM X 1.25 HXHD	1
7R001-006	#6 STNLS HOSE CLAMP, NARROW	2	7G010-175	12MM X 1.75 NUT	1
7R004-002	STEPLESS CLAMP 17.0-70	2	7J012-092	12MM WASHER, FLAT	3
7R004-687	STEPLESS CLAMP, 13/16"	4	7J312-000	5/16 FLAT WASHER-SAE	11
7U030-053	3/8 X 90 MOLDED RUBBER HOSE	1	7J375-044	3/8 SAE WASHER, PLTD	4
4CL010-060	BRKT, CHGR ENG CVR SPT FRONT	1	7K250-001	1/4" AN WASHER	6
4CL010-070	BRKT, CHGR ENG CVR SPT UPPER	1	7U100-068	BUMPER, RBR Ø.5X.25 MTG HOLE	2
4CL010-080	BRKT, CHGR ENG CVR SPT LOWER	1	7U100-069	KEY, 3/16 SQUARE X .73 LONG	1
7A250-074	1/4-20 X .75 HHCS PLTD	1	7U100-073	KEY, 3/16 SQUARE X 1.375 LONG	1
7F250-021	1/4-20 NYLOCK NUT ZINC PLATED	1	7U100-084	SNAP RING, V9	1
7J250-001	1/4 WASER, SAE, PLTD	2	7X100-027	WAVE WASHER-LARGE (V-2)	1
7U100-068	BUMPER, RBR Ø .5X.25 MTG HOLE	1	4CL110-110*	ASSY, DAMPER PIN	1
8F060-008	FUEL INJ, 07 CHARGER SC	8	4CL112-010*	AIR DISCHARGE ASSY	1
4CL110-044	S/C MTG BRKT ASSY	1	4CL112-030*	AIR INLET ASSEMBLY, HEMI	1
2A017-016	PILOT, 3/8 SCREW	1	5A003-080	IN-TUNE, DIABLOSPORT	1
2A017-093	SPACER, S/C PULLEY, .093"	1	8N006-020	WATER COOLER	1
2A017-156	SPACER, IDLER, HEMI	1	8N105-190*	WATER TANK MTG ASSY	1
2A017-105-222	SPACER, 1"OD .328" ID, 2.225"L	7	8N107-190*	WATER PUMP MTG ASSY	1
2A017-462	SPACER, IDLER SMOOTH 6RIB	1	5W001-011	16-14 GA RING TERM .26" HOLE	1
2A017-876-12	SPACER, .875 OD X .475 LONG	2	5W001-013	14-16 GA BUTT CONN BLU INSUL	2
2A036-136	S/C PULLEY 3.60" 6 GROOVE W/FLG	1	5W001-024	MINI ATC FUSE TAP	1
2A040-011	PULLEY RETAINER S/C	2	5W001-025	FEMALE SLIDE, INSULATED, MINI	1
2A042-080	BELT, GATES 20MM, 80 TOOTH	1	5W001-054	18 GA FUSE HOLDER	1
2D070-159	LARGE BEARING, EXTENDED DRIVE	2	5W014-030	14GA STRD WIRE BLACK	5
2D070-171	JACKSHAFT, C5, H900	1	7R003-027	ADEL CLAMP, 1-11/16"	1
4CL010-010	BRKT, PWR STR MTG, 07 CHGR	1	8F001-402	PUMP, WATER, PIERBURG	1
4CL010-020	PLATE, HEAD MTG, 07 CHGR	1	8N100-001	NYLON MOUNTING KIT	1
4CL010-044	PLATE, SC MTG, 07 CHGR	1	8N201-380	WELDED CLR ASSY	1
4CL010-050	MTG TAB, CHARGER CLR SPT	2			
4CL016-011	HUB, PWR STR PLY, HEMICAR	1			
4CL016-021	PULLEY, PWR STR, HEMICAR	1			
4FT017-080	SPCR, COOLER SUPPORT	1			
4GR032-032	PULLEY, JACKSHAFT, C5, 20MM, 32T	1			

*SEE PAGE Xi FOR INDIVIDUAL COMPONENTS IN ASSEMBLY



2005-2010 Hemi 6.1L SRT-8 Supercharger Kit Part No. 4CL218-030L **PARTS LIST**

IMPORTANT: Before beginning installation, verify that all parts are included in the kit. Report any shortages or damaged parts immediately.

PART NO.	DESCRIPTION	QTY	PART NO.	DESCRIPTION	QTY
008118	DECAL, VINYL, VORTECH	2	4CL110-100	FUEL SYSTEM ASSY, SRT-8 CAR	1
008130	LICENSE PLATE FRAME, VORTECH	1	4CL010-100	OIL FILL CAP, SRT-8	1
008341	VORTECH CHARGE COOLER DECAL	1	7P375-156	3/8"X3/8"X5/32" MALE BARB TEE	1
008447	1 YR S/C STRT INFO PKG ASY VOR	1	7R001-006	#6 STNLS HOSE CLAMP, NARROW	2
009035	S/C LUBE, BOTTLED, VORT 3-PACK	1	8F060-008	FUEL INJ, 07 CHARGER SC	8
2A046-106	BELT PREMIUM 104.5", GATES	1	5A002-017	MAP SENSOR, 07 CHARGER SC	1
2F329-130	V3 S/C ASY, 6.1L HEMI SRT8 30T	1	4CL110-110*	ASSY, DAMPER PIN	1
4CL010-160	BRKT, FLDYNE CHLLNGR DRVR	1	4CL112-010*	AIR DISCHARGE ASSY	1
4CL010-170	BRKT, FLDYNE CHLLNGR PASS	1	4CL112-030*	AIR INLET ASSY, HEMI	1
4CL010-251	BRKT, CAC SUPRT, HEMI CHALL	1	5A003-080	IN-TUNE, DIABLOSPORT	1
4CL020-010	MANUAL, DODGE HEMI CHGR	1	5A102-031	ASSY, VOLT BOOST SRT8 HEMI G3	1
4CL110-044	S/C MTG BRKT ASSY, HEMI	1	5A002-031	VOLT BOOSTER HEMI G3	1
2A017-016	PILOT, 3/8 SCREW	1	5W001-021	1/2" SPLIT PLASTIC WIRE LOOM	2'
2A017-093	SPACER, S/C PULLEY, .093"	1	5W001-005	3/8" SPLIT PLASTIC WIRE LOOM	9'
2A017-156	SPACER, IDLER, HEMI	1	5W001-032	1/4" SPLIT PLASTIC WIRE LOOM	20'
2A017-105-222	SPACER, 1"OD .328" ID, 2.225"L	7	5W012-000	12GA. RED STRANDED WIRE	4'
2A017-462	SPACER, IDLER SMOOTH 6RIB	1	5W012-010	12GA. BLACK STRANDED WIRE	4'
2A017-876-12	SPACER, .875 OD X .475 LONG	2	5W012-080	12GA. ORANGE STRANDED WIRE	8'
2A036-136	S/C PULLEY 3.60" 6 GROOVE W/FLG	1	5W014-010	14GA. RED STRANDED WIRE	8'
2A040-011	PULLEY RETAINER S/C	2	7U030-024	1/8" NYLON INSTRUMENT TUBING	21'
2A042-080	BELT, GATES 20MM, 80 TOOTH	1	7P156-082	5/32" TEE	1
2D070-159	LARGE BEARING, EXTENDED DRIVE	2	7U030-109	7/64" VAC HOSE	.5'
2D070-171	JACKSHAFT, C5, H900	1	7U100-044	4" NYLON TIE WRAPS	10
4CL010-010	BRKT, PWR STR MTG, 07 CHGR	1	7U100-055	7.5" NYLON TIE WRAPS	10
4CL010-020	PLATE, HEAD MTG, 07 CHGR	1	5W001-014	FUSE HOLDER 10GA. WIRE	1
4CL010-044	PLATE, SC MTG, 07 CHGR	1	4CL010-260	MOUNTING PLATE FPB	1
4CL010-050	MTG TAB, CHARGER CLR SPT	2	7C010-050	10-24 X 1/2" SCREWS	4
4CL016-011	HUB, PWR STR PLY, HEMICAR	1	7J010-001	#10 FLAT WASHER	4
4CL016-021	PULLEY, PWR STR, HEMICAR	1	7F010-024	10-24 NYLOCK NUT	4
4FT017-080	SPCR, COOLER SUPPORT	1	7A250-074	1/4-20 X 3/4" HEX HEAD BOLT	2
4GR032-032	PULLEY, JACKSHAFT, C5, 20MM, 32T	1	7J250-001	1/4" WASHER	4
4GR116-300	IDLER ASSY, 20MM BELT	1	7F250-022	1/4-20 NYLOCK NUTS	2
4CL116-350	IDLER ASSY, 20 MM, SRT8 3.5	1	5W001-007	3/16 HEAT SHRINK	.75'
7J500-002	1/2" LOCK WASHER	1	5W001-038	1/4 HEAT SHRINK	.75'
4FD017-011	PILOT, 6205 BRG 1/2" SCREW	1	5W001-043	10-12GA. 1/4" YELLOW RING TERMINAL	2
4HS017-041	SPACER, LOWER S/C PLT S2000	2	5W001-041	10-12GA. YELLOW SLIDE CONN MALE	2
4NZ030-041	BRG HSG, 350Z	1	5W001-040	10-12GA. YELLOW SLIDE CONN FEMALE	2
7A250-075	1/4-20 X .75 SHCS	6	5W001-019	10-12GA. YELLOW BUTT CONN	1
7A312-152	5/16-18 X 1.5 SHCS, ZN PLT	4	5W001-009	14-16GA. BLUE SLIDE CONN MALE	1
7A375-100	3/8-16X1 G5 HXHD PLT	4	5W001-010	14-16GA. BLUE SLIDE CONN FEMALE	1
7A375-225	3/8-16 X 2 1/4" G8 HX HD	1	5W001-013	14-16GA. BLUE BUTT CONN	2
7B375-075	3/8-24 X 3/4" GR8 HXHD BOLT	1	8N006-020	WATER COOLER	1
7B375-150	3/8-24X 1-1/2 GR8 HX	1	8N105-190*	WATER TANK MTG ASSY	1
7C012-100	12MM X 100MM X 1.75 HXHD BOLT	1	8N107-190*	WATER PUMP MTG ASSY, 07 CHGR	1
7C080-066	M8 X 1.25 X 65 HXHD CL10.9	1	8N201-380	WELDED CLR ASSY	1
7C080-090	M8 X 1.25 X 90 HXHD CL10.9	7			
7C080-100	M8 X 1.25 X 100 HXHD ZN PLT	3			
7C080-120	BOLT, 8MM X 120MM X 1.25 HXHD	1			
7G010-175	12MM X 1.75 NUT	1			
7J012-092	12MM WASHER, FLAT	3			
7J312-000	5/16 FLAT WASHER-SAE	11			
7J375-044	3/8 SAE WASHER, PLTD	4			
7K250-001	1/4" AN WASHER	6			
7U100-068	BUMPER, RBR Ø.5X.25 MTG HOLE	2			
7U100-069	KEY, 3/16 SQUARE X .73 LONG	1			
7U100-073	KEY, 3/16 SQUARE X 1.375 LONG	1			
7U100-084	SNAP RING, V9	1			
7X100-027	WAVE WASHER-LARGE (V-2)	1			

*SEE PAGE xii FOR INDIVIDUAL COMPONENTS IN ASSEMBLY



ENGINEERING, INC.

2009-2010 5.7L M6 Challenger Supercharger Kit

Part No. 4CL218-040L

PARTS LIST

IMPORTANT: Before beginning installation, verify that all parts are included in the kit. Report any shortages or damaged parts immediately.

PART NO.	DESCRIPTION	QTY	PART NO.	DESCRIPTION	QTY
008118	DECAL, VINYL, VORTECH	2	7C080-100	M8 X 1.25 X 100 HXHD ZN PLT	3
008130	LICENSE PLATE FRAME, VORTECH	1	7C080-120	BOLT, 8MM X 120MM X 1.25 HXHD	1
008341	VORTECH CHARGE COOLER DECAL	1	7G010-175	12MM X 1.75 NUT	1
008447	1 YR S/C STRT INFO PKG ASY VOR	1	7J012-092	12MM WASHER, FLAT	1
009035	S/C LUBE, BOTTLED, VORT 3-PACK	1	7J312-000	5/16 FLAT WASHER-SAE	11
2A046-106	BELT PREMIUM 104.5", GATES	1	7J375-044	3/8 SAE WASHER, PLTD	4
2F329-130	V3 S/C ASY, 6.1L HEMI SRT8 30T	1	7J500-002	1/2" WASHER, SPLIT LOCK	1
4CL010-160	BRKT, FLDYNE CHLLNGR DRVR	1	7U100-068	BUMPER, RBR .5 X .25 MTG HOLE	2
4CL010-170	BRKT, FLDYNE CHLLNGR PASS	1	7U100-069	KEY, 3/16 SQUARE X .73 LONG	1
4CL010-251	BRKT, CAC SUPRT, HEMI CHALL	1	7U100-073	KEY, 3/16 SQUARE X 1.375 LONG	1
4CL020-010	MANUAL, DODGE HEMI CHGR	1	7U100-084	SNAP RING, EXT DRV HOUSING	1
4CL110-032	FUEL SYSTEM ASSY, 5.7L HEMI	1	7X100-027	WAVE WASHER, LARGE, V2 INPUT	1
4CL010-030	MAP SENSOR BLOCK, 07 CHARGER	1	7C080-025	M8 X 1.25 X 25 HXHD	3
4CL014-010	THERMOSTAT, 180° HEMI CAR	1	2A017-750-09	SPACER, .75 OD X .328 ID X .36	3
4CL145-010	ASSY, FUEL LINE, 2009 5.7L HEM	1	4CL110-060ASM, P/S, 09 5.7L M6 HEMI CHAL		1
5A002-017	MAP SENSOR, 07 CHARGER SC	1	7P375-075	3/4" HOSE BARB UNION, BRASS	1
5A002-024	CONNECTR, MAP SNSR, 09 5.7L HE	1	7R004-007	STEPLESS CLAMP, 28.6 X 7MM WID	2
5A002-025	SENSOR, IAT, 2005-08 DODGE HEM	1	7R002-010	#10 SAE TYPE F SS HOSE CLAMP	1
7A250-074	1/4-20 X .75 HHCS PLTD	1	7P500-078	1/2NPT X 3/4 HOSE FIT STRT	1
7C010-052	10-24 X 1/2 BUTTN HEAD CRWW	2	7P500-036	1/2 NPT, STREET, 45 DEG	1
7F250-021	1/4-20 NYLOCK NUT ZINC PLATED	1	4CL010-241	FITTING, P/S, 09 5.7L M6 HEMI	1
7J250-001	1/4 WASHER, SAE, PLTD	2	5A002-024	CONNECTOR, MAP SENSOR, 5.7L HE	1
7P062-187	1/16NPT X 3/16 HOSE BARB	1	4CL110-110*	ASSY, DAMPER PIN, HEMI	1
7P250-045	1/4 MALE NPT X 3/8 MALE BARB	2	4CL112-010*	AIR DISCHARGE ASSY,HEMI CAR	1
7P375-113	PCV VALVE, VIPER, 3/8"-1/2" BA	1	4CL112-030*	AIR INLET ASSY, HEMI	1
7P500-003	1/2"-3/8" REDUCER BARB UNION	1	5A003-080	IN-TUNE, DIABLOSPORT	1
7R001-006	#6 STNLS HOSE CLAMP, NARROW	2	5A102-031	ASSY, VOLT BOOST SRT8 HEMI G3	1
7R004-002	STEPLESS CLAMP, 17.0-70	2	5A002-031	VOLT BOOSTER HEMI G3	1
7R004-687	STEPLESS CLAMP,13/16" ONE EAR	4	5W001-021	1/2" SPLIT PLASTIC WIRE LOOM	2'
7U030-053	3/8 X 90° MOLDED RUBBER HOSE	1	5W001-005	3/8" SPLIT PLASTIC WIRE LOOM	9'
8F060-008	FUEL INJECTOR, HEMI CHARGER	8	5W001-032	1/4" SPLIT PLASTIC WIRE LOOM	20'
4CL110-054	ASSY, S/C MTG BRKT,09 5.7L M6	1	5W012-000	12GA. RED STRANDED WIRE	4'
008725	CAP, TAMPER PROOF, VORT S/C	2	5W012-010	12GA. BLACK STRANDED WIRE	4'
2A017-016	PILOT, 6203/5 BRG, 3/8 SCREW	1	5W012-080	12GA. ORANGE STRANDED WIRE	8'
2A017-093	SPACER, S/C PULLEY, .093"	1	5W014-010	14GA. RED STRANDED WIRE	8'
2A017-105-222	SPACER, 1"OD X .328"ID X 2.225	5	7U030-024	1/8" NYLON INSTRUMENT TUBING	21'
2A017-462	SPACER, IDLER SMOOTH 6RIB	1	7P156-082	5/32" TEE	1
2A017-156	SPCR, SM IDLER, DBL BRG JACK	1	7U030-109	7/64" VAC HOSE	.5'
2A036-136	S/C PULLEY 3.60" 6 GROOVE W/FL	1	7U100-044	4" NYLON TIE WRAPS	10
2A040-051	PLY RETAINER, TAMPER PRF CAP	2	7U100-055	7.5" NYLON TIE WRAPS	10
2A040-061	RETAINER CUP, VORT S/C PLY	2	5W001-014	FUSE HOLDER 10GA. WIRE	1
2A042-080	BELT, GATES 20MM, 80 TOOTH	1	4CL010-260	MOUNTING PLATE FPB	1
2D070-159	LARGE BEARING,EXTENDED DRIVE	2	7C010-050	10-24 X 1/2" SCREWS	4
2D070-171	JACKSHAFT, C5, H900, 1INCH	1	7J010-001	#10 FLAT WASHER	4
4CL010-230	PLATE, SUPPORT, REAR, 09 5.7L	1	7F010-024	10-24 NYLOCK NUT	4
4CL010-221	PLATE, CYL HEAD, 09 5.7L M6 HE	1	7A250-074	1/4-20 X 3/4" HEX HEAD BOLT	2
4CL010-044	PLATE, SC MTG, 07 CHGR	1	7J250-001	1/4" WASHER	4
4CL010-251	CAC, SUPPORT BRACKET, 09 5.7L	1	7F250-022	1/4-20 NYLOCK NUTS	2
4CL116-350	IDLER ASSY, 20MM GILMER, SRT8	1	5W001-007	3/16 HEAT SHRINK	.75'
4FD017-011	PILOT, 6203/5 BRG, 1/2 SCREW	1	5W001-038	1/4 HEAT SHRINK	.75'
4FT017-080	SPCR, COOLER SUPPORT	1	5W001-043	10-12GA. 1/4" YELLOW RING TERMINAL	2
4GR032-032	PULLEY,JACKSHAFT,C5,20MM,32T	1	5W001-041	10-12GA. YELLOW SLIDE CONN MALE	2
4GR116-300	IDLER ASSY, 20MM GILMER, C5	1	5W001-040	10-12GA. YELLOW SLIDE CONN FEMALE	2
4HS017-041	SPACER, LOWER S/C PLT S2000	2	5W001-019	10-12GA. YELLOW BUTT CONN	1
4NZ030-041	BEARING HSG, 350Z	1	5W001-009	14-16GA. BLUE SLIDE CONN MALE	1
7A312-152	5/16-18 X 1.5 SHCS, ZN PLT	4	5W001-010	14-16GA. BLUE SLIDE CONN FEMALE	1
7A375-124	3/8-16 X 1-1/4 HHCS, G5, PLATE	4	5W001-013	14-16GA. BLUE BUTT CONN	2
7A375-225	3/8-16 X 2-1/4 HXHD G8	1	8N006-020	WATER COOLR, FLDYN DUAL PASS	1
7B375-075	3/8-24 X 3/4" GR8 HXHD BOLT	1	8N105-190*	WATER TANK MTG ASSY, 07 CHGR	1
7B375-150	3/8-24 X 1-1/2 GR8 HX	1	8N107-190*	WATER PUMP MTG ASSY, 07 CHGR	1
7C012-100	12MM X 100MM X 1.75 HXHD BOLT	1	8N201-380	WELDED CLR ASSY, 07 HEMI CHGR	1
7C080-090	M8 X 1.25 X 90 HXHD CL.10.9	3			

*SEE PAGE xiii FOR INDIVIDUAL COMPONENTS IN ASSEMBLY



2009-2010 5.7L Automatic Challenger Supercharger Kit

Part No. 4CL218-050L

PARTS LIST

IMPORTANT: Before beginning installation, verify that all parts are included in the kit. Report any shortages or damaged parts immediately.

PART NO.	DESCRIPTION	QTY	PART NO.	DESCRIPTION	QTY
008118	DECAL, VINYL, VORTECH	2	7C012-100	12MM X 100MM X 1.75 HXHD BOLT	1
008130	LICENSE PLATE FRAME, VORTECH	1	7C080-066	M8 X 1.25 X 65 HXHD CL10.9	1
008341	VORTECH CHARGE COOLER DECAL	1	7C080-090	M8 X 1.25 X 90 HXHD CL10.9	7
008447	1 YR S/C STRT INFO PKG ASY VOR	1	7C080-100	M8 X 1.25 X 100 HXHD ZN PLT	3
009035	S/C LUBE, BOTTLED, VORT 3-PACK	1	7C080-120	BOLT, 8MM X 120MM X 1.25 HXHD	1
2A046-106	BELT PREMIUM 104.5", GATES	1	7G010-175	12MM X 1.75 NUT	1
2F329-130	V3 S/C ASY, 6.1L HEMI SRT8 30T	1	7J012-092	12MM WASHER, FLAT	3
4CL010-160	BRKT, FLDYNE CHLLNGR DRVR	1	7J312-000	5/16 FLAT WASHER-SAE	11
4CL010-170	BRKT, FLDYNE CHLLNGR PASS	1	7J375-044	3/8 SAE WASHER, PLTD	4
4CL010-251	BRKT, CAC SUPRT, HEMI CHALL	1	7K250-001	1/4" AN WASHER	6
4CL020-010	MANUAL, DODGE HEMI CHGR	1	7U100-068	BUMPER, RBR Ø.5X.25 MTG HOLE	2
4CL110-032	FUEL SYSTEM ASSY, 5.7L HEMI	1	7U100-069	KEY, 3/16 SQUARE X .73 LONG	1
4CL010-030	MAP SENSOR BLOCK, 07 CHARGER	1	7U100-073	KEY, 3/16 SQUARE X 1.375 LONG	1
4CL014-010	THERMOSTAT, 180° HEMI CAR	1	7U100-084	SNAP RING,V9	1
4CL145-010	ASSY, FUEL LINE, 2009 5.7L HEM	1	7X100-027	WAVE WASHER-LARGE (V-2)	1
5A002-017	MAP SENSOR, 07 CHARGER SC	1	4CL110-110*	ASSY, DAMPER PIN, HEMI	1
5A002-024	CONNECTR, MAP SNSR, 09 5.7L HE	1	4CL112-010*	AIR DISCHARGE ASSY,HEMI CAR	1
5A002-025	SENSOR, IAT, 2005-08 DODGE HEM	1	4CL112-030*	AIR INLET ASSY, HEMI	1
7A250-074	1/4-20 X .75 HHCS PLTD	1	5A003-080	IN-TUNE, DIABLOSPORT	1
7C010-052	10-24 X 1/2 BUTTN HEAD CRWW	2	5A102-031	ASSY, VOLT BOOST SRT8 HEMI G3	1
7F250-021	1/4-20 NYLOCK NUT ZINC PLATED	1	5A002-031	VOLT BOOSTER HEMI G3	1
7J250-001	1/4 WASHER, SAE, PLTD	2	5W001-021	1/2" SPLIT PLASTIC WIRE LOOM	2'
7P062-187	1/16NPT X 3/16 HOSE BARB	1	5W001-005	3/8" SPLIT PLASTIC WIRE LOOM	9'
7P250-045	1/4 MALE NPT X 3/8 MALE BARB	2	5W001-032	1/4" SPLIT PLASTIC WIRE LOOM	20'
7P375-113	PCV VALVE, VIPER, 3/8"-1/2" BA	1	5W012-000	12GA. RED STRANDED WIRE	4'
7P500-003	1/2"-3/8" REDUCER BARB UNION	1	5W012-010	12GA. BLACK STRANDED WIRE	4'
7R001-006	#6 STNLS HOSE CLAMP, NARROW	2	5W012-080	12GA. ORANGE STRANDED WIRE	8'
7R004-002	STEPLESS CLAMP, 17.0-70	2	5W014-010	14GA. RED STRANDED WIRE	8'
7R004-687	STEPLESS CLAMP,13/16" ONE EAR	4	7U030-024	1/8" NYLON INSTRUMENT TUBING	21'
7U030-053	3/8 X 90° MOLDED RUBBER HOSE	1	7P156-082	5/32" TEE	1
8F060-008	FUEL INJECTOR, HEMI CHARGER	8	7U030-109	7/64" VAC HOSE	.5'
4CL110-044	S/C MTG BRKT ASSY	1	7U100-044	4" NYLON TIE WRAPS	10
2A017-016	PILOT, 3/8 SCREW	1	7U100-055	7.5" NYLON TIE WRAPS	10
2A017-093	SPACER, S/C PULLEY, .093"	1	5W001-014	FUSE HOLDER 10GA. WIRE	1
2A017-156	SPACER, IDLER, HEMI	1	4CL010-260	MOUNTING PLATE FPB	1
2A017-105-222	SPACER, 1"OD .328" ID, 2.225"L	7	7C010-050	10-24 X 1/2" SCREWS	4
2A017-462	SPACER, IDLER SMOOTH 6RIB	1	7J010-001	#10 FLAT WASHER	4
2A017-876-12	SPACER, .875 OD X .475 LONG	2	7F010-024	10-24 NYLOCK NUT	4
2A036-136	S/C PULLEY 3.60" 6 GROOVE W/FLG	1	7A250-074	1/4-20 X 3/4" HEX HEAD BOLT	2
2A040-011	PULLEY RETAINER S/C	2	7J250-001	1/4" WASHER	4
2A042-080	BELT, GATES 20MM, 80 TOOTH	1	7F250-022	1/4-20 NYLOCK NUTS	2
2D070-159	LARGE BEARING,EXTENDED DRIVE	2	5W001-007	3/16 HEAT SHRINK	.75'
2D070-171	JACKSHAFT, C5, H900	1	5W001-038	1/4 HEAT SHRINK	.75'
4CL010-010	BRKT, PWR STR MTG, 07 CHGR	1	5W001-043	10-12GA. 1/4" YELLOW RING TERMINAL	2
4CL010-020	PLATE, HEAD MTG, 07 CHGR	1	5W001-041	10-12GA. YELLOW SLIDE CONN MALE	2
4CL010-044	PLATE,SC MTG, 07 CHGR	1	5W001-040	10-12GA. YELLOW SLIDE CONN FEMALE	2
4CL010-050	MTG TAB, CHARGER CLR SPT	2	5W001-019	10-12GA. YELLOW BUTT CONN	1
4CL016-011	HUB, PWR STR PLY, HEMICAR	1	5W001-009	14-16GA. BLUE SLIDE CONN MALE	1
4CL016-021	PULLEY, PWR STR, HEMICAR	1	5W001-010	14-16GA. BLUE SLIDE CONN FEMALE	1
4FT017-080	SPCR, COOLER SUPPORT	1	5W001-013	14-16GA. BLUE BUTT CONN	2
4GR032-032	PULLEY,JACKSHAFT,C5,20MM,32T	1	8N006-020	WATER COOLR, FLDYN DUAL PASS	1
4GR116-300	IDLER ASSY, 20MM BELT	1	8N105-190*	WATER TANK MTG ASSY, 07 CHGR	1
4CL116-350	IDLER ASSY, 20 MM, SRT8 3.5	1	8N107-190*	WATER PUMP MTG ASSY, 07 CHGR	1
7J500-002	1/2" LOCK WASHER	1	8N201-380	WELDED CLR ASSY, 07 HEMI CHGR	1
4FD017-011	PILOT, 6205 BRG 1/2" SCREW	1			
4HS017-041	SPACER, LOWER S/C PLT S2000	2			
4NZ030-041	BRG HSG, 350Z	1			
7A250-075	1/4-20 X .75 SHCS	6			
7A312-152	5/16-18 X 1.5 SHCS, ZN PLT	4			
7A375-100	3/8-16X1 G5 HXHD PLT	4			
7A375-225	3/8-16 X 2 1/4" G8 HX HD	1			
7B375-075	3/8-24 X 3/4" GR8 HXHD BOLT	1			
7B375-150	3/8-24X 1-1/2 GR8 HX	1			

*SEE PAGE XIV FOR INDIVIDUAL COMPONENTS IN ASSEMBLY



ENGINEERING, INC.

2005-2008 Hemi 5.7L Car Tuner Kit

Part No. 4CL218-110L

PARTS LIST

IMPORTANT: Before beginning installation, verify that all parts are included in the kit. Report any shortages or damaged parts immediately.

PART NO.	DESCRIPTION	QTY	PART NO.	DESCRIPTION	QTY
008118	DECAL, VINYL, VORTECH	2	8N006-020	WATER COOLER	1
008130	LICENSE PLATE FRAME, VORTECH	1	8N105-190	WATER TANK MTG ASSY, 07 CHGR	1
008341	POWERCOOLER DECAL	1	7A250-051	1/4-20 X .50" HHCS PLTD	2
008447	S/C STREET PACKAGE ASSEMBLY	1	7A250-101	1/4-20 X 1 HHCS ZINC PLTD	1
009035	LUBE ASSY, 3-PACK	1	7U100-027	PLASTIC RIVET, BUMPER CVR	6
2A046-106	BELT PREMIUM 104.5", GATES	1	4FT017-080	SPACER, COOLER SUPPORT .5"L	1
2F329-030*	S/C ASSY, V3 CCW SI STR 07 CHGR	1	4CL010-190	BRACKET RESERVOIR	1
4CL010-030	MAP SENSOR BLOCK	1	7A250-050	1/4-20 X .50 SHCS ZINC PLTD	3
4CL020-010	MANUAL, 2007 DODGE HEMI CHGR 5.7L	1	7E010-075	#12 X 3/4" SHT METL SCRW HEX	8
4CL110-044*	S/C MTG BRKT ASSY, 07 CHARGER	1	7P375-075	3/4" HOSE UNION	3
4CL110-110	ASSY, DAMPER PIN, CHGR	1	7P500-026	1/2NPT X 3/4 BARB 90° BRASS	3
4GR010-110	GUIDE, DWL PIN INST	1	7P500-750	1/2NPT-3/4 BARB 90° SHORT	2
7C014-095	M14-1.5 X 95MM SHCS	1	7P500-078	1/2NPT X 3/4 HOSE FIT STRT	1
7U250-019	DOWEL PIN, 1/4X1/2 +.001"	1	7R007-001	NYLON RATCHET CLAMP 1-1/8"	16
7U250-026	DRILL BUSHING, 1/4 ID, 3/8 OD, 1/2L	1	7U030-065	3/4"X90° RUBBER HOSE, SHORT	3
4CL112-010	AIR DISCHARGE ASSY, 07 CHGR	1	7U038-000	3/4" HEATER HOSE	14
4CL012-010(8)	DUCT, CAC TO T-BODY	1	7U038-012	HOSE, 3/4"DIA 90 ,4X12 LEGS	4
4CL112-020(8)	DISCH TUBE, SC TO CAC	1	7U100-044	TIE WRAP, 4" NYLON	10
5A002-018	IAT HARNESS EXT, HEMI	1	7U100-055	TIE WRAP, 7.5" NYLON	10
7S275-092	ELBOW, 2.75 X 90 SILICONE	1	8N055-030	TANK, WATER, TRIANGLE SHAPE	1
7S275-300	SLEEVE, 2.75" X 3.00"L, BLUE	2	8N055-050	PLASTIC CAP, SURGE TANK	1
7S350-277	ELBOW, 3.5 X 2.75 90° SILICONE	1	8N056-060	SURGE TANK, PLASTIC	1
7R002-016	#16 SAE TYPE F SS HOSE CLAMP	2	4CL010-110	BRKT, FLUIDYNE RAD. MTG. SHORT	1
7R002-044	#44 SAE TYPE F SS HOSE CLAMP	7	4CL010-120	BRKT, FLUIDYNE RAD. MTG. LONG	1
7R002-056	#56 SAE TYPE F SS HOSE CLAMP	1	4CL010-130	BRKT, SURGE TANK MTG, HEMI CAR	1
7U030-046	5/32" VACUUM LINE	7	4CL010-140	BRKT, FLUIDYNE RAD 300L SHORT	1
7U034-016	1" GS HEATER HOSE	0.25	4CL010-150	FLUIDYNE RAD 300L LONG	1
8D001-001	STD COMPRESS BYPASS VALVE	1	4CL010-160	BRKT, FLUIDYNE, CHLGR DRVR	1
8H040-300	AIR FILTER, 3.5" OFFSET, 300C	1	4CL010-170	BRKT, FLUIDYNE, CHLGR PSGR	1
4CL010-050	BRKT, CLR SPT, CHGR	2	4GJ014-020	WATER TUBE B, GTO	1
4CL010-060	BRKT, ENG CVR SPT FRONT	1	8N107-190	WATER PUMP MTG ASSY, 07 CHGR	1
4CL010-070	BRKT, ENG CVR SPT UPPER	1	5W001-011	16-14 GA RING TERM .26" HOLE	1
4CL010-080	BRKT, ENG CVR SPT LOWER	1	5W001-013	14-16 GA BUTT CONN BLU INSUL	2
4CL112-030	AIR INLET ASSY, HEMI	1	5W001-024	MINI ATC FUSE TAP	1
4CL010-180	BRKT, CHALLENGER AIR INLET	1	5W001-025	FEMALE SLIDE, INSULATED, MINI	1
4CL012-030	DUCT, INLET 08 HEMI CHALLENGER	1	5W001-054	18 GA FUSE HOLDER	1
7A250-039	1/4-20 X 3/8" SHCS ZINC PLTD	2	5W014-030	14GA STRD WIRE BLACK	5
7J250-001	1/4 WASHER, SAE, PLTD	2	7R003-027	ADEL CLAMP, 1-11/16"	1
7R002-056	#56 SAE TYPE F SS HOSE CLAMP	1	8F001-402	PUMP, WATER, PIERBURG	1
7R002-080	#80 SAE TYPE F SS HOSE CLAMP	1	8N100-001	NYLON MOUNTING KIT	1
7S500-351	INLET SLEEVE, HEMI, 5 X 3.5	1	8N201-380	WELDED CLR ASSY	1
8H040-235	AIR FILTER, 4" FLG X 7.0L	1			
7P500-009	1/2"X90 HOSE BARB UNION	1			
7U030-036	1/2" OIL DRAIN HOSE	4'			
8H040-300	AIR FILTER 300C	1			
7U032-020	3/8 P/S HOSE	32"			

*SEE PAGE vii FOR INDIVIDUAL COMPONENTS IN ASSEMBLY



2005-2010 Hemi 6.1L SRT-8 Car Tuner Kit

Part No. 4CL218-130L

PARTS LIST

IMPORTANT: Before beginning installation, verify that all parts are included in the kit. Report any shortages or damaged parts immediately.

PART NO.	DESCRIPTION	QTY	PART NO.	DESCRIPTION	QTY
008118	DECAL, VINYL, VORTECH	2	8N006-020	WATER COOLER	1
008130	LICENSE PLATE FRAME, VORTECH	1	8N105-190	WATER TANK MTG ASSY	1
008341	VORTECH CHARGE COOLER DECAL	1	7A250-051	1/4-20 X .50" HHCS PLTD	2
008447	1 YR S/C STRT INFO PKG ASY VOR	1	7A250-101	1/4-20 X 1 HHCS ZINC PLTD	1
009035	S/C LUBE, BOTTLED, VORT 3-PACK	1	7U100-027	PLASTIC RIVET, BUMPER CVR	6
2A046-106	BELT PREMIUM 104.5", GATES	1	4FT017-080	SPACER, COOLER SUPPORT .5"L	1
2F329-130	V3 S/C ASY, 6.1L HEMI SRT8 30T	1	4CL010-190	BRACKET RESERVOIR	1
4CL010-100	OIL FILL CAP, SRT-8	1	7A250-050	1/4-20 X .50 SHCS ZINC PLTD	3
4CL010-160	BRKT, FLDYNE CHLLNGR DRVR	1	7E010-075	#12 X 3/4" SHT METL SCRW HEX	8
4CL010-170	BRKT, FLDYNE CHLLNGR PASS	1	7P375-075	3/4" HOSE UNION	3
4CL020-010	MANUAL, DODGE HEMI CHGR	1	7P500-026	1/2NPT X 3/4 BARB 90° BRASS	3
4CL110-044*	S/C MTG BRKT ASSY, HEMI	1	7P500-750	1/2NPT-3/4 BARB 90° SHORT	2
4CL110-110	ASSY, DAMPER PIN	1	7P500-078	1/2NPT X 3/4 HOSE FIT STRT	1
4GR010-110	GUIDE, DWL PIN INST	1	7R007-001	NYLON RATCHET CLAMP 1-1/8"	16
7C014-095	M14-1.5 X 95MM SHCS	1	7U030-065	3/4"X90° RUBBER HOSE, SHORT	3
7U250-019	DOWEL PIN, 1/4X1/2 +.001"	1	7U038-000	3/4" HEATER HOSE	14
7U250-026	DRILL BUSHING, 1/4 ID, 3/8 OD, 1/2L	1	7U038-012	HOSE, 3/4"DIA 90 .4X12 LEGS	4
4CL112-010	AIR DISCHARGE ASSY	1	7U100-044	TIE WRAP, 4" NYLON	10
4CL012-010(8)	DUCT, CAC TO T-BODY	1	7U100-055	TIE WRAP, 7.5" NYLON	10
4CL112-020(8)	DISCH TUBE, SC TO CAC	1	8N055-030	TANK, WATER, TRIANGLE SHAPE	1
5A002-018	IAT HARNESS EXT, HEMI	1	8N055-050	PLASTIC CAP, SURGE TANK	1
7S275-092	ELBOW, 2.75 X 90 SILICONE	1	8N056-060	SURGE TANK, PLASTIC	1
7S275-300	SLEEVE, 2.75" X 3.00"L, BLUE	2	4CL010-110	BRKT, FLUIDYNE RAD. MTG, SHORT	1
7S350-277	ELBOW, 3.5 X 2.75 90° SILICONE	1	4CL010-120	BRKT, FLUIDYNE RAD. MTG, LONG	1
7R002-016	#16 SAE TYPE F SS HOSE CLAMP	2	4CL010-130	BRKT, SURGE TANK MTG, HEMI CAR	1
7R002-044	#44 SAE TYPE F SS HOSE CLAMP	7	4CL010-140	BRKT, FLUIDYNE RAD 300L SHORT	1
7R002-056	#56 SAE TYPE F SS HOSE CLAMP	1	4CL010-150	FLUIDYNE RAD 300L LONG	1
7U030-046	5/32" VACUUM LINE	7	4CL010-160	BRKT, FLUIDYNE, CHLGR DRVR	1
7U034-016	1" GS HEATER HOSE	0.25	4CL010-170	BRKT, FLUIDYNE, CHLGR PSGR	1
8D001-001	STD COMPRESS BYPASS VALVE	1	4GJ014-020	WATER TUBE B, GTO	1
8H040-300	AIR FILTER, 3.5" OFFSET, 300C	1	8N107-190	WATER PUMP MTG ASSY, 07 CHGR	1
4CL010-050	BRKT, CLR SPT, CHGR	2	5W001-011	16-14 GA RING TERM .26" HOLE	1
4CL010-060	BRKT, ENG CVR SPT FRONT	1	5W001-013	14-16 GA BUTT CONN BLU INSUL	2
4CL010-070	BRKT, ENG CVR SPT UPPER	1	5W001-024	MINI ATC FUSE TAP	1
4CL010-080	BRKT, ENG CVR SPT LOWER	1	5W001-025	FEMALE SLIDE, INSULATED, MINI	1
4CL112-030	AIR INLET ASSY, HEMI	1	5W001-054	18 GA FUSE HOLDER	1
4CL010-180	BRKT, CHALLENGER AIR INLET	1	5W014-030	14GA STRD WIRE BLACK	5
4CL012-030	DUCT, INLET 08 HEMI CHALLENGER	1	7R003-027	ADEL CLAMP, 1-11/16"	1
7A250-039	1/4-20 X 3/8" SHCS ZINC PLTD	2	8F001-402	PUMP, WATER, PIERBURG	1
7J250-001	1/4 WASHER, SAE, PLTD	2	8N100-001	NYLON MOUNTING KIT	1
7R002-056	#56 SAE TYPE F SS HOSE CLAMP	1	8N201-380	WELDED CLR ASSY	1
7R002-080	#80 SAE TYPE F SS HOSE CLAMP	1			
7S500-351	INLET SLEEVE, HEMI, 5 X 3.5	1			
8H040-235	AIR FILTER, 4" FLG X 7.0L	1			
7P500-009	1/2"X90 HOSE BARB UNION	1			
7U030-036	1/2" OIL DRAIN HOSE	4'			
8H040-300	AIR FILTER 300C	1			
7U032-020	3/8 P/S HOSE	32"			

*SEE PAGE viii FOR INDIVIDUAL COMPONENTS IN ASSEMBLY



ENGINEERING, INC.

2009-2010 5.7L M6 Challenger Tuner Kit

Part No. 4CL218-140L

PARTS LIST

IMPORTANT: Before beginning installation, verify that all parts are included in the kit. Report any shortages or damaged parts immediately.

PART NO.	DESCRIPTION	QTY	PART NO.	DESCRIPTION	QTY
008118	DECAL, VINYL, VORTECH	2	7C010-052	10-24 X 1/2 BUTTN HEAD CRWW	2
008130	LICENSE PLATE FRAME, VORTECH	1	8N006-020	WATER COOLER	1
008341	VORTECH CHARGE COOLER DECAL	1	8N105-190	WATER TANK MTG ASSY	1
008447	1 YR S/C STRT INFO PKG ASY VOR	1	7A250-051	1/4-20 X .50" HHCS PLTD	2
009035	S/C LUBE, BOTTLED, VORT 3-PACK	1	7A0250-101	1/4-20 X 1 HHCS ZINC PLTD	1
2A046-106	BELT PREMIUM 104.5", GATES	1	7U100-027	PLASTIC RIVET, BUMPER CVR	6
2F329-130*	V3 S/C ASY, 6.1L HEMI SRT8 30T	1	4FT017-080	SPACER, COOLER SUPPORT .5" L	1
4CL010-030	MAP SENSOR BLOCK	1	4CL010-190	BRACKET RESERVOIR	1
4CL010-160	BRKT, FLDYNE CHLLNGR DRVR	1	7A250-050	1/4-20 X .50 SHCS ZINC PLTD	3
4CL010-170	BRKT, FLDYNE CHLLNGR PASS	1	7E010-075	#12 X 3/4" SHT METL SCRW HEX	8
4CL010-251	BRKT, CAC SUPRT, HEMI CHALL	1	7P375-075	3/4" HOSE UNION	3
4CL020-010	MANUAL, DODGE HEMI CHGR	1	7P500-026	1/2NPT X 3/4 BARB 90° BRASS	3
4CL110-054*ASSY, S/C MTG BRKT,09 5.7L M6		1	7P500-750	1/2NPT-3/4 BARB 90° SHORT	2
4CL110-060 ASM, P/S, 09 5.7L M6 HEMI CHAL		1	7P500-078	1/2NPT X 3/4 HOSE FIT STRT	1
4CL110-110	ASSY, DAMPER PIN	1	7R007-001	NYLON RATCHET CLAMP 1-1/8"	16
4GR010-110	GUIDE, DWL PIN INST	1	7U030-065	3/4"X90° RUBBER HOSE, SHORT	3
7C014-095	M14-1.5 X 95MM SHCS	1	7U038-000	3/4" HEATER HOSE	14
7U250-019	DOWEL PIN, 1/4X1/2 +.001"	1	7U038-012	HOSE,3/4"DIA 90 ,4X12 LEGS	4
7U250-026	DRILL BUSHING, 1/4 ID, 3/8 OD, 1/2L	1	7U100-044	TIE WRAP, 4" NYLON	10
4CL112-010	AIR DISCHARGE ASSY	1	7U100-055	TIE WRAP, 7.5" NYLON	10
4CL012-010(8)	DUCT, CAC TO T-BODY	1	8N055-030	TANK, WATER, TRIANGLE SHAPE	1
4CL112-020(8)	DISCH TUBE, SC TO CAC	1	8N055-050	PLASTIC CAP, SURGE TANK	1
5A002-018	IAT HARNESS EXT, HEMI	1	8N056-060	SURGE TANK, PLASTIC	1
7S275-092	ELBOW, 2.75 X 90 SILICONE	1	4CL010-110	BRKT, FLUIDYNE RAD. MTG, SHORT	1
7S275-300	SLEEVE, 2.75" X 3.00"L, BLUE	2	4CL010-120	BRKT, FLUIDYNE RAD. MTG, LONG	1
7S350-277	ELBOW, 3.5 X 2.75 90° SILICONE	1	4CL010-130	BRKT, SURGE TANK MTG, HEMI CAR	1
7R002-016	#16 SAE TYPE F SS HOSE CLAMP	2	4CL010-140	BRKT, FLUIDYNE RAD 300L SHORT	1
7R002-044	#44 SAE TYPE F SS HOSE CLAMP	7	4CL010-150	FLUIDYNE RAD 300L LONG	1
7R002-056	#56 SAE TYPE F SS HOSE CLAMP	1	4CL010-160	BRKT, FLUIDYNE, CHLGR DRVR	1
7U030-046	5/32" VACUUM LINE	7	4CL010-170	BRKT, FLUIDYNE, CHLGR PSGR	1
7U034-016	1" GS HEATER HOSE	0.25	4GJ014-020	WATER TUBE B, GTO	1
8D001-001	STD COMPRESS BYPASS VALVE	1	8N107-190	WATER PUMP MTG ASSY, 07 CHGR	1
8H040-300	AIR FILTER, 3.5" OFFSET, 300C	1	5W001-011	16-14 GA RING TERM .26" HOLE	1
4CL010-050	BRKT, CLR SPT, CHGR	2	5W001-013	14-16 GA BUTT CONN BLU INSUL	2
4CL010-060	BRKT, ENG CVR SPT FRONT	1	5W001-024	MINI ATC FUSE TAP	1
4CL010-070	BRKT, ENG CVR SPT UPPER	1	5W001-025	FEMALE SLIDE,INSULATED,MINI	1
4CL010-080	BRKT, ENG CVR SPT LOWER	1	5W001-054	18 GA FUSE HOLDER	1
4CL112-030	AIR INLET ASSY, HEMI	1	5W014-030	14GA STRD WIRE BLACK	5
4CL010-180	BRKT, CHALLENGER AIR INLET	1	7R003-027	ADEL CLAMP,1-11/16"	1
4CL012-030	DUCT, INLET 08 HEMI CHALLENGER	1	8F001-402	PUMP, WATER, PIERBURG	1
7A250-039	1/4-20 X 3/8" SHCS ZINC PLTD	2	8N100-001	NYLON MOUNTING KIT	1
7J250-001	1/4 WASHER, SAE, PLTD	2	8N201-380	WELDED CLR ASSY	1
7R002-056	#56 SAE TYPE F SS HOSE CLAMP	1			
7R002-080	#80 SAE TYPE F SS HOSE CLAMP	1			
7S500-351	INLET SLEEVE, HEMI, 5 X 3.5	1			
8H040-235	AIR FILTER, 4" FLG X 7.0L	1			
7P500-009	1/2"X90 HOSE BARB UNION	1			
7U030-036	1/2" OIL DRAIN HOSE	4'			
8H040-300	AIR FILTER 300C	1			
7U032-020	3/8 P/S HOSE	32"			

*SEE PAGE IX FOR INDIVIDUAL COMPONENTS IN ASSEMBLY



2009-2010 5.7L Automatic Challenger Tuner Kit

Part No. 4CL218-150L PARTS LIST

IMPORTANT: Before beginning installation, verify that all parts are included in the kit. Report any shortages or damaged parts immediately.

PART NO.	DESCRIPTION	QTY	PART NO.	DESCRIPTION	QTY
008118	DECAL, VINYL, VORTECH	2	7U032-020	3/8 P/S HOSE	32"
008130	LICENSE PLATE FRAME, VORTECH	1	7C010-052	10-24 X 1/2 BUTTN HEAD CRWW	2
008341	VORTECH CHARGE COOLER DECAL	1	8N006-020	WATER COOLER	1
008447	1 YR S/C STRT INFO PKG ASY VOR	1	8N105-190	WATER TANK MTG ASSY	1
009035	S/C LUBE, BOTTLED, VORT 3-PACK	1	7A250-051	1/4-20 X .50" HHCS PLTD	2
2A046-106	BELT PREMIUM 104.5", GATES	1	7A0250-101	1/4-20 X 1 HHCS ZINC PLTD	1
2F329-130*	V3 S/C ASY, 6.1L HEMI SRT8 30T	1	7U100-027	PLASTIC RIVET, BUMPER CVR	6
4CL010-030	MAP SENSOR BLOCK	1	4FT017-080	SPACER, COOLER SUPPORT .5" L	1
4CL010-160	BRKT, FLDYNE CHLLNGR DRVR	1	4CL010-190	BRACKET RESERVOIR	1
4CL010-170	BRKT, FLDYNE CHLLNGR PASS	1	7A250-050	1/4-20 X .50 SHCS ZINC PLTD	3
4CL010-251	BRKT, CAC SUPRT, HEMI CHALL	1	7E010-075	#12 X 3/4" SHT METL SCRW HEX	8
4CL020-010	MANUAL, DODGE HEMI CHGR	1	7P375-075	3/4" HOSE UNION	3
4CL110-044*	S/C MTG BRKT ASSY, HEMI	1	7P500-026	1/2NPT X 3/4 BARB 90° BRASS	3
4CL110-110	ASSY, DAMPER PIN	1	7P500-750	1/2NPT-3/4 BARB 90° SHORT	2
4GR010-110	GUIDE, DWL PIN INST	1	7P500-078	1/2NPT X 3/4 HOSE FIT STRT	1
7C014-095	M14-1.5 X 95MM SHCS	1	7R007-001	NYLON RATCHET CLAMP 1-1/8"	16
7U250-019	DOWEL PIN, 1/4X1/2 +.001"	1	7U030-065	3/4"X90° RUBBER HOSE, SHORT	3
7U250-026	DRILL BUSHING, 1/4 ID, 3/8 OD, 1/2L	1	7U038-000	3/4" HEATER HOSE	14
4CL112-010	AIR DISCHARGE ASSY	1	7U038-012	HOSE, 3/4" DIA 90, 4X12 LEGS	4
4CL012-010(8)	DUCT, CAC TO T-BODY	1	7U100-044	TIE WRAP, 4" NYLON	10
4CL112-020(8)	DISCH TUBE, SC TO CAC	1	7U100-055	TIE WRAP, 7.5" NYLON	10
5A002-018	IAT HARNESS EXT, HEMI	1	8N055-030	TANK, WATER, TRIANGLE SHAPE	1
7S275-092	ELBOW, 2.75 X 90 SILICONE	1	8N055-050	PLASTIC CAP, SURGE TANK	1
7S275-300	SLEEVE, 2.75" X 3.00" L, BLUE	2	8N056-060	SURGE TANK, PLASTIC	1
7S350-277	ELBOW, 3.5 X 2.75 90° SILICONE	1	4CL010-110	BRKT, FLUIDYNE RAD. MTG, SHORT	1
7R002-016	#16 SAE TYPE F SS HOSE CLAMP	2	4CL010-120	BRKT, FLUIDYNE RAD. MTG, LONG	1
7R002-044	#44 SAE TYPE F SS HOSE CLAMP	7	4CL010-130	BRKT, SURGE TANK MTG, HEMI CAR	1
7R002-056	#56 SAE TYPE F SS HOSE CLAMP	1	4CL010-140	BRKT, FLUIDYNE RAD 300L SHORT	1
7U030-046	5/32" VACUUM LINE	7	4CL010-150	FLUIDYNE RAD 300L LONG	1
7U034-016	1" GS HEATER HOSE	0.25	4CL010-160	BRKT, FLUIDYNE, CHLGR DRVR	1
8D001-001	STD COMPRESS BYPASS VALVE	1	4CL010-170	BRKT, FLUIDYNE, CHLGR PSGR	1
8H040-300	AIR FILTER, 3.5" OFFSET, 300C	1	4GJ014-020	WATER TUBE B, GTO	1
4CL010-050	BRKT, CLR SPT, CHGR	2	8N107-190	WATER PUMP MTG ASSY, 07 CHGR	1
4CL010-060	BRKT, ENG CVR SPT FRONT	1	5W001-011	16-14 GA RING TERM .26" HOLE	1
4CL010-070	BRKT, ENG CVR SPT UPPER	1	5W001-013	14-16 GA BUTT CONN BLU INSUL	2
4CL010-080	BRKT, ENG CVR SPT LOWER	1	5W001-024	MINI ATC FUSE TAP	1
4CL112-030	AIR INLET ASSY, HEMI	1	5W001-025	FEMALE SLIDE, INSULATED, MINI	1
4CL010-180	BRKT, CHALLENGER AIR INLET	1	5W001-054	18 GA FUSE HOLDER	1
4CL012-030	DUCT, INLET 08 HEMI CHALLENGER	1	5W014-030	14GA STRD WIRE BLACK	5
7A250-039	1/4-20 X 3/8" SHCS ZINC PLTD	2	7R003-027	ADEL CLAMP, 1-11/16"	1
7J250-001	1/4 WASHER, SAE, PLTD	2	8F001-402	PUMP, WATER, PIERBURG	1
7R002-056	#56 SAE TYPE F SS HOSE CLAMP	1	8N100-001	NYLON MOUNTING KIT	1
7R002-080	#80 SAE TYPE F SS HOSE CLAMP	1	8N201-380	WELDED CLR ASSY	1
7S500-351	INLET SLEEVE, HEMI, 5 X 3.5	1			
8H040-235	AIR FILTER, 4" FLG X 7.0L	1			
7P500-009	1/2"X90 HOSE BARB UNION	1			
7U030-036	1/2" OIL DRAIN HOSE	4'			
8H040-300	AIR FILTER 300C	1			

*SEE PAGE X FOR INDIVIDUAL COMPONENTS IN ASSEMBLY

1. PREPARATION AND REMOVAL

- A. Disconnect negative cable at the battery.
- B. Remove the plastic engine covers and set aside.
- C. Remove the valve cover breather hose from the factory air inlet duct. Remove the air filter and all ducting upstream of the throttle body.
- D. All models except 2009-2010 5.7L: Unplug the IAT (Inlet Air Temperature) sensor connector and remove it from the air filter housing. Set it aside for later use.
- E. Remove the accessory drive belt.
- F. Unplug the fan electrical connector, then remove fan shroud hardware. Pull up and remove the electric radiator fan assembly from the vehicle (cooling system may need to be drained and upper radiator hose removed).
- G. Using an appropriate power steering pulley removal tool, remove the power steering pump pulley from the pump.
- H. Install the supplied power steering pulley hub onto the power steering pump so that it is flush with the end of the shaft. (See Fig. 1-a)

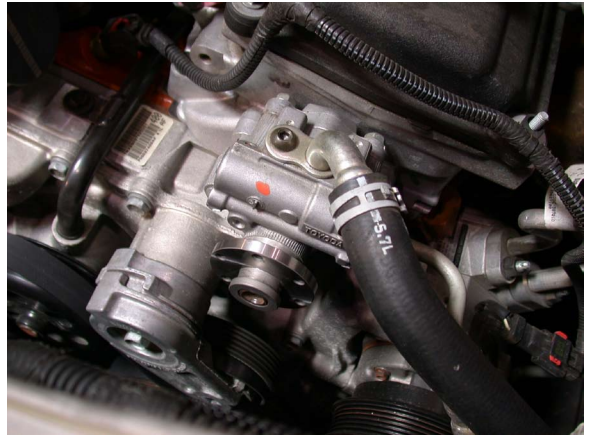

Fig. 1-a

11. FRONT FASCIA REMOVAL

1. Remove the plastic splash pan on the bottom of the vehicle.
2. Remove the electrical plug for the fog lights located on the passenger side of the vehicle.
3. Remove the plastic rivets securing the inner fender liners (new rivets are supplied for re-installation).
4. Locate the two 10mm headed screws in the front outer edge of the inner fender (one on each side of the vehicle) (See Fig 5.A-1. Remove the screws and set aside to be re-installed in a later step.
5. Locate and remove the four 10 mm nuts (Two on each side of the vehicle) (See Fig 5.A-2)
6. Remove the two covers from the top of the fascia (See Fig 5.A-3)
7. Remove the six plastic retaining clips securing the top of the fascia to the radiator core support.
8. Gently pull the corners of the fascia way from the fenders. And remove the fascia.
9. Remove the plastic clips retaining the inner fascia support. And remove the inner fascia support. (See Fig 5.A-4, 5.A-5)

(300C and 2008 Magnum: skip to section 2. All others proceed as follows)

10. Remove the three 8 mm headed screws from the drivers side headlight.
11. Pull the headlight straightforward and remove.
12. Remove the two head light plugs. And set the head light assembly aside.



Fig. 5.A-1 (Challenger Shown)



Fig. 5.A-2 (Challenger Shown)



Fig. 5.A-3 (Challenger Shown)



2. HARMONIC DAMPER DOWEL PIN INSTALLATION

NOTE: The purpose of this section is to provide access to the harmonic damper bolt area so that the crankshaft can be pinned to the damper to prevent the damper from spinning on the crankshaft. The following steps will work on all or most applications. If it is not possible to get adequate clearance by performing the following steps, follow the manufacturer's steps for removing the harmonic damper until there is sufficient room to work in.

- A. Remove the crankshaft damper bolt. (A factory tool may be used to keep the engine from rotating or carefully use a pry tool to keep the damper from rotating.)
- B. Install the supplied drill guide with the raised section piloting in the damper bore. Secure in place by installing the supplied socket head cap screw. Do not over-tighten the screw as it may distort the drill guide (its purpose is just to hold the guide in place while drilling). See Fig. 2-a.
- C. Using a small drill motor (right angle pneumatic works well), mark a 1/4" drill bit with electrical tape or a drill stop so that the hole will be deep enough for the supplied 1/2" long dowel pin. See Fig. 2-b.
- D. Drill hole in damper/crankshaft.
- E. Remove the socket head cap screw.
- F. Clean area of metal chips and install the supplied dowel pin in the drilled hole making sure that it does not protrude past the damper face.
- G. Install and tighten the crankshaft damper bolt to 129 ft-lbs (176 Nm).
- H. Re-install the radiator fans and verify that the electrical connector is plugged in.



Fig. 2-a



Fig. 2-b

3. FUEL INJECTOR REPLACEMENT

- A. Relieve the fuel system pressure
- B. Disconnect the eight fuel injector plugs and retaining clips from the injectors.

NOTE: Do not reinstall the factory injector retaining clips onto the new injectors.

- C. Remove the four screws that hold down the fuel rail on the intake manifold. Lift up on the rails evenly and remove all eight injectors.
- D. Using a small amount of clean motor oil, lightly lubricate the O-rings on both ends of the Vortech supplied fuel injectors.
- E. Install the new injectors into the fuel rails with the terminals facing outward.
- F. Carefully lower the fuel rail/injector assembly down onto the intake manifold. **2009-2010 5.7L Challenger Only:** Fuel Rail must be mounted 180° from original position so that fuel inlet is now located on the passenger side.
- G. Check to see that each injector has been seated properly into the intake manifold.
- H. Tighten down the passenger side of the fuel rail assembly with the original bolts and attach the injector plugs to the injectors.
- I. **(5.7L vehicles only)** Cut the engine cover mounting pedestals off of the two driver side fuel rail fasteners.
- J. Install the driver side fasteners through the two supplied charge cooler core support brackets and tighten the driver side fuel rail (See Fig. 3-a). Use the shorter pair of brackets for the 6.1L and the longer pair for the 5.7L. Ensure that the supplied rubber bumpers are installed into the CAC support brackets.
- K. **(5.7L vehicles only)** Use the supplied PCV valve, 1/2" to 3/8" hose union and 3/8" 90° hose to splice into the factory crank case breather hose as shown in Fig. 3-b.
- L. Tighten a stepless clamp on each hose connection.
- M. **(5.7L engine only)** Cut the brake booster line next to the brake booster and install the aluminum MAP sensor block assembly. Install a clamp on each connection. Unplug the connector from the factory MAP sensor on the back of the intake manifold and plug it into the supplied MAP sensor. (See Fig. 3-c) **2009-2010 5.7L Challenger Only:** Install dummy plug into factory MAP sending unit to keep it from rotating out.
- N. **(6.1L engine only)** Cut the brake booster line next to the brake booster and install the supplied TEE. Install a clamp on each connection. Remove the factory MAP sensor from the back of the intake manifold. Install the supplied MAP sensor into the factory location and plug it in.

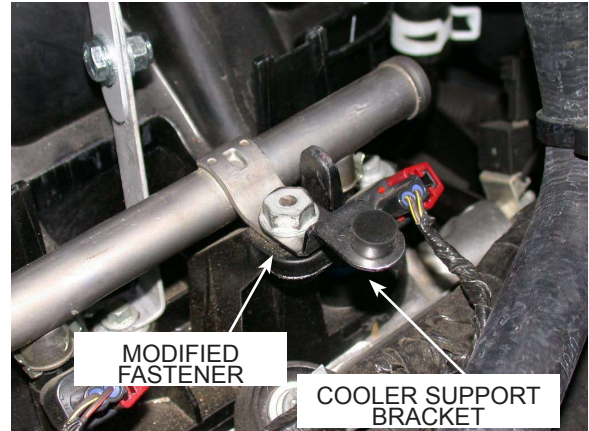

Fig. 3-a (5.7L Shown, 6.1L Similar)



Fig. 3-b



Fig. 3-c

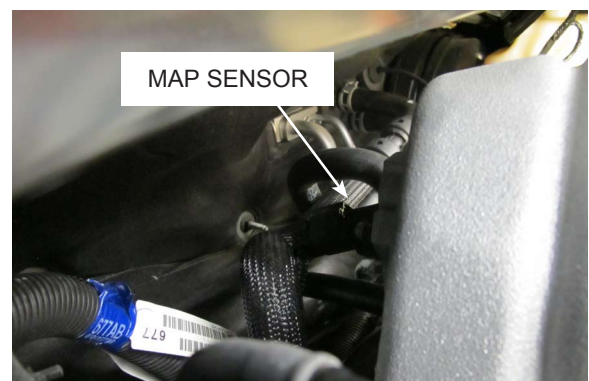

4. SUPERCHARGER MOUNTING PLATE INSTALLATION

- A. Remove the three bolts securing the power steering pump to the head.
- B. Loosely attach the steel bracket to the back of the primary mounting plate.
- C. Attach the supercharger mounting plate to the primary mounting plate using the supplied M8 x90mm bolts and spacers.
- D. Without installing hardware, sandwich the power steering pump between the steel plate and the supercharger mounting plate.

NOTE: This is difficult to accomplish with the power steering lines connected. It may be easier to completely remove the power steering pump from the vehicle and install into the mounting bracket assembly out of the vehicle.

2009-2010 5.7L engines require removal of the inlet fitting for the power steering pump to be replaced with the supplied fitting. Set aside the hose as it will be used in a later step. Refer to Fig. 4-b for final installation reference.

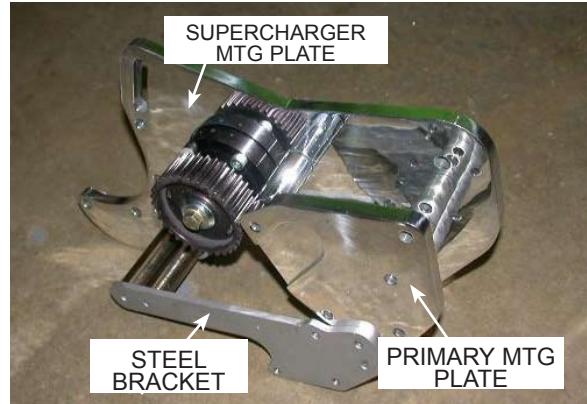

Fig. 4-a

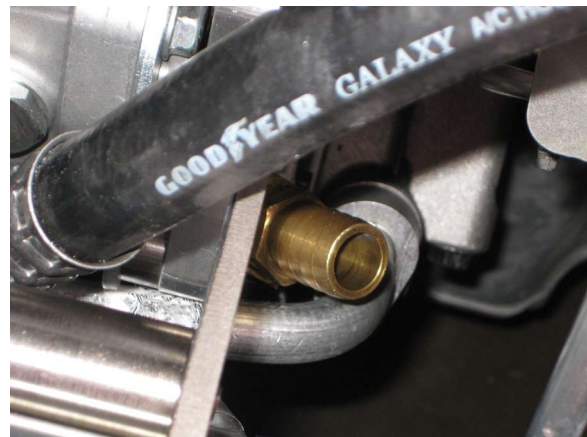

Fig. 4-b (2009-2010 5.7L Challenger and M6 6.1L)

4. SUPERCHARGER MOUNTING PLATE INSTALLATION

- E. Start the supplied 8mm bolt in the outside hole making sure that it does not protrude through the back and impact the a/c line (2009-2010 5.7L engines bend the a/c lines slightly as necessary. Zip tie a piece of supplied 3/4" hose to bracket to prevent rubbing. See Fig. 4-c).
- F. Install a .475" spacer between the supercharger mounting plate and the power steering pump at the two remaining power steering pump mounting holes. Install 8mm x 90mm bolts and washers.
- G. Position the supercharger mounting plate assembly in front of the engine and secure it to the head using the three M8 x 100 mm bolts and one M8 x 120mm bolt. (See Fig. 4-d).
- H. Tighten all of the mounting plate bolts in steps so that the protruding bolt heads do not hit the power steering pump pulley.

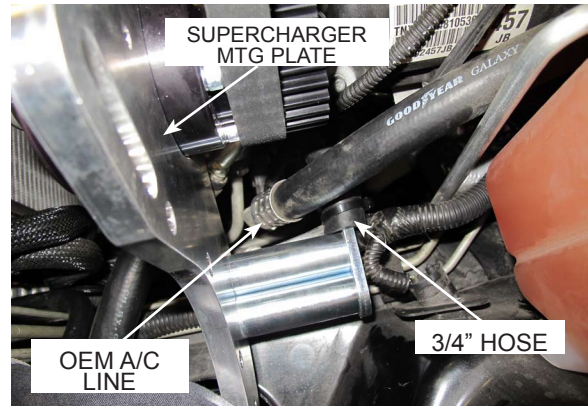

Fig. 4-c

NOTE: Only 2009-2010 5.7L Challengers M6 continue with steps I, J, K. All other systems reattach the power steering lines now and skip to section 5.



Fig. 4-d

4. SUPERCHARGER MOUNTING PLATE INSTALLATION, CONT'D

Steps I, J and K apply to 2009-2010 5.7L Challenger M6 Only:

- I. Remove power steering hose from pump to reservoir. Cut hose as depicted in Figure 4-e Set aside the two longer pieces of hose and discard the two shorter pieces. Replace the small bend with a $\frac{3}{4}$ hose union and attach the 2 pieces of hose together.
- J. Install hose so that the end with the single bend attaches to the pump. Do not install clamps. Mark union for correct clocking. Remove hose from car and install stepless clamps at union (See Fig. 4-f).
- K. Install hose assembly back into car using the factory clamp to secure the hose to the reservoir and a supplied hose clamp to attach the hose to the power steering pump.



Fig. 4-e (2009-2010 5.7L Charger/Challenger)



Fig. 4-f (2009-2010 5.7L Charger/Challenger)

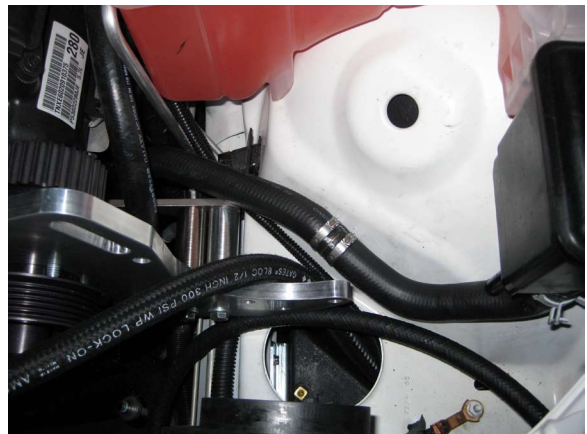

Fig. 4-g (2009-2010 5.7L Charger/Challenger)

5. SUPERCHARGER INSTALLATION

- A. **(This step applies to 300C and 2008 Magnum vehicles only. All others skip to step B)** Install a 1/2" breather hose from the engine to the hole in the air filter using the supplied barbed fitting. Insert the air filter into the space behind the driver side headlight for later attachment to the supercharger inlet. (See Fig. 5-a)

NOTE: 1/2" hose should point towards the passenger side and then back under the supercharger plate and up to the manifold port.

- B. Install the supplied 3" aluminum idler in the lower 3/8-16 hole for the 6.1L and in the upper 3/8-16 hole for the 5.7L. Make sure that the snap ring side is facing forward (away from the mounting plate). (See Fig. 5-b). **2009-2010 5.7L Challenger models** will use inner most hole on mounting plate for idler pulley.
- C. Install the supplied power steering pump pulley on the already installed hub using the supplied 1/4" hardware.
- D. Install the supplied accessory drive belt (as shown in Fig. 5-c).
- E. Position the supercharger in front of the mounting plate assembly in front of the engine and install and tighten the four 3/8" x 1 1/4" bolts.
- F. **(This step applies to 300C and 2008 Magnum vehicles only. All others skip to step G)** Install the air filter onto the supercharger inlet and tighten the clamp.
- G. Install the supplied gilmer (toothed) belt around the pulleys on the mounting plate assembly.
- H. Using the supplied M12 x 100mm bolt, install the supplied 3.5" aluminum idler with the bearing retaining snap ring pointed towards the front of the vehicle. The screw should pass through a flat washer, S/C mounting plate, 1.55" idler spacer, the idler, thick bearing washer, lock washer and nut. Install the supplied nut and lock washer on the end of the screw and tighten the idler so that the gilmer belt is snug. (See Fig. 5-d).
- I. Secure the remote drain hose away from the belt and hoses using tie-wraps.

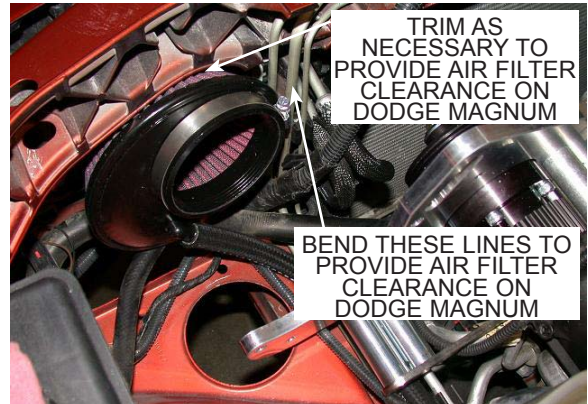

Fig. 5-a

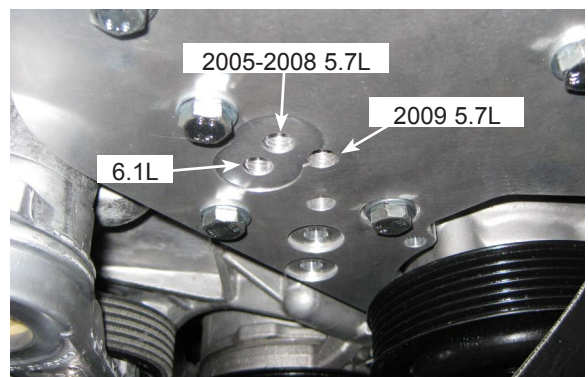

Fig. 5-b

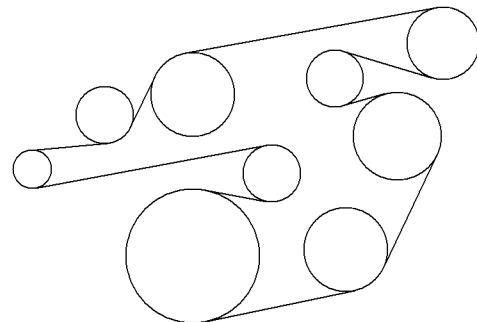

Fig. 5-c



Fig. 5-d

6. AIR INLET INSTALLATION (300C and 2008 Magnum installations skip to section 7. All others proceed as follows)

1. Locate assembly (4CL112-030) insure that all parts are present.
2. Attach the rubber sleeve to the plastic duct with the hose claps provided.
3. Attach the air filter to the inlet duct. (See Fig 6-a)
4. Attach the mounting bracket to the duct with the fasteners provided. (See Fig 6-b)
5. Remove the 15 mm headed bolt at the bottom of the core support. Set the bolt aside to be reinstalled in a later step (See Fig 6-c)



Fig. 6-a



Fig. 6-b



Fig. 6-c

6. AIR INLET INSTALLATION, CONT'D (300C and 2008 Magnum installations skip to section 7. All others proceed as follows)

6. Remove the hood latch cable clip and move to the side to be reattached to the inlet duct-mounting bracket in a later step.
7. Remove the 3/8" power steering hose from the drivers side of power steering cooler and from the reservoir. Set aside; it will not be used.
8. Locate the 30-inch piece of power steering hose that is provided. Install the hose clamps from the factor power steering hose.
9. Route the new power steering hose down and behind the core support between the radiator and the core support. (See Fig 6-d)
10. Attach the inlet duct to the inlet of the super-charger and secure with the hose clamp previously installed.
11. Reinstall the 15 mm headed bolt removed in an earlier step. Attach the hood latch cable to the bracket supporting the inlet duct. (See Fig 6-e)
12. Attach the crank case breather hose to the 90° plastic fitting on the end of the air filter. (See Fig 6-f)
13. Route the breather hose through the round hole located in the inner fender to the crank case breather fitting on the intake manifold.
14. Check the power steering fluid level and re-fill as necessary.
15. Re-install headlight, hardware and connectors.



Fig. 6-d



Fig. 6-e



Fig. 6-f

7. CHARGE AIR COOLER CORE AND SURGE TANK INSTALLATION

1. Using sealant, install two “short” 90 degree fittings (two of the supplied 90° fittings have shorter hose barbs than the others) into the CAC end tank. Point the upper one horizontally towards the driver side and point the lower one down. (See Fig. 7-a)
2. Install a 90° fitting into the bottom of the surge tank and point it towards the front of the vehicle. Install a straight fitting into the side of the surge tank.
3. Attach the supplied surge tank to the strut tower using the supplied bracket and ¼-20 x ½” socket head cap screws (See Fig. 7-b).
4. Install molded 90° hoses onto the barbed fittings on the CAC core and point them forward.
5. Lower the CAC into place over the driver side valve cover.
6. Attach the 90° hose connected to the upper fitting on the cooler end tank to the straight fitting installed in the side of the surge tank (trim hose as needed).
7. Verify that all water hose connections have tightened clamps installed.
8. Trim the strut top cover as needed and reinstall. (See Fig 7-c).



Fig. 7-a



Fig. 7-b



Fig. 7-c

8. RESERVOIR AND WATER PUMP ASSEMBLY AND INSTALLATION

1. Attach the water reservoir bracket to the reservoir using $\frac{1}{4}$ -20 x .5" cap screws. (See Fig. 8-a for bracket orientation).
2. In the area in front of the driver side front wheel, position the water reservoir/bracket next to the frame rail. Orient the assembly for best clearance, at least 6" from the rear face of the bumper (See Fig. 8-b)
3. Mark mounting bracket location and remove. Drill two $\frac{11}{64}$ " holes for the supplied #12 sheet metal screws (See Fig. 8-c).
4. Using thread sealant, install the $\frac{1}{2}$ " NPT 90° hose barb fitting into the top and bottom of the supplied plastic reservoir.
5. Secure the assembly to the frame rail using two #12 sheet metal screws.
6. Trial fit the front bumper cover to verify water reservoir clearance.
7. Cut off the electrical plug on the water pump leaving as much wire connected to the pump as possible. Install the supplied $\frac{1}{4}$ " eyelet on the water pump ground wire (brown wire).
8. Connect the pump inlet to the bottom reservoir fitting with a piece of the supplied hose. Point pump to discharge up at a 45° angle for 300C vehicles, or forward (and slightly up, to allow air to escape the pump housing) for all other vehicles. Secure hose with clamps on both ends. Drill a hole in the radiator support and secure the water pump to it using an adel clamp and #12 sheet metal screw. Make sure to ground the fuel pump under the mounting screw. (See Fig. 8-d)
9. Connect a hose to the top of the reservoir and run it up to the area next to the driver side valve cover. This hose will later be connected to the 90 degree fitting installed in the bottom of the supplied surge tank (trim for ideal routing).
10. Drill a $\frac{5}{8}$ hole in rear facing side of the power distribution box lid approx. 3 inches from inner edge. Insert supplied grommet into hole. Install supplied fuse holder from inside of lid, pressing one end into the grommet. Connect fuse tap and slide connector to fuel pump fuse referring to the owner's manual. Connect remaining end of fuse holder to water pump wire using supplied wire. Route wire behind engine following the factory loom. Install supplied split loom over wire (See Fig. 8-e).

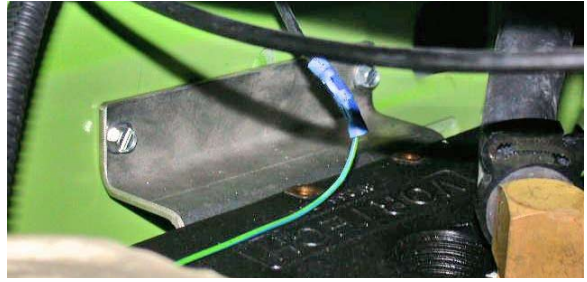

Fig. 8-a



Fig. 8-b



Fig. 8-c



Fig. 8-d

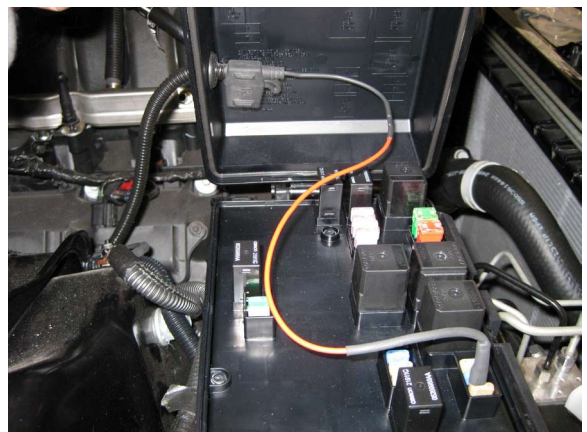

Fig. 8-e

9. CHARGE AIR COOLER RADIATOR INSTALLATION

1. **(Challenger vehicles only. All others skip to step 2)** Attach the supplied brackets to each side of the CAC radiator as shown in figs. 9-a and 9-b. Remove the two small plastic panels from the front bumper cover as shown in Fig. 9-c. Skip to step 5.
2. **(300C vehicles only. All others skip to step 3)** Attach the longer pair of the supplied brackets to the charge air cooler radiator. The driver side bracket should be attached by sandwiching the supplied $\frac{1}{2}$ " long spacer between the bracket and the CAC radiator. (See Fig. 9-d). With the foam bumper installed on the vehicle position the CAC radiator with brackets on top of the steel bumper so that it has about $\frac{1}{2}$ " clearance behind it. Mark the four frontmost mounting bracket holes to be drilled. Remove assembly, drill $\frac{11}{64}$ " holes and install the CAC radiator using four #12 sheet metal screws. (See Fig. 9-e). 300C models skip ahead to 9.5
3. Attach the shorter pair of the supplied brackets to the charge air cooler radiator. The driver side bracket should be attached by sandwiching the supplied $\frac{1}{2}$ " long spacer between the bracket and the CAC radiator. (See Fig. 9-f).

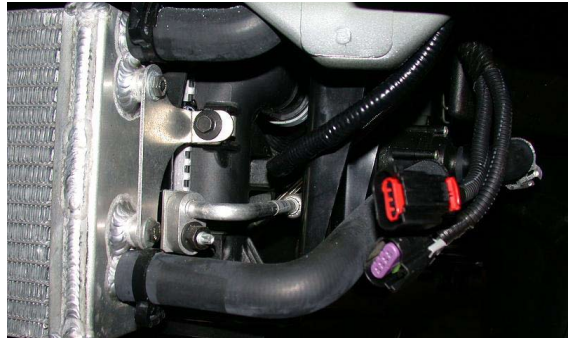

Fig. 9-a



Fig. 9-b

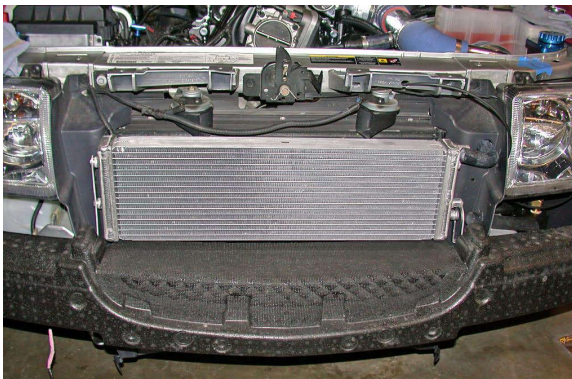

Fig. 9-e



Fig. 9-c

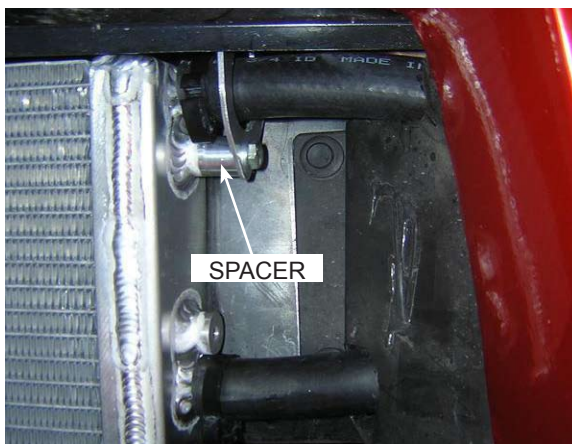

Fig. 9-f

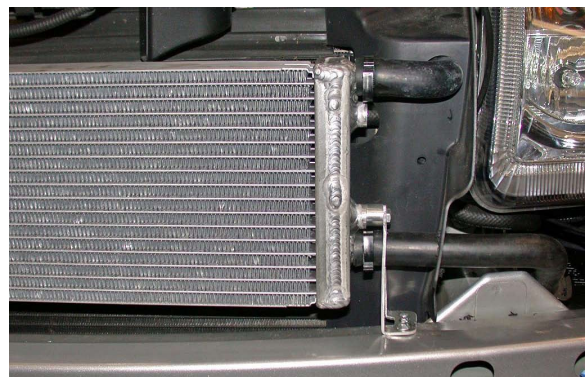

Fig. 9-d

9. CHARGE AIR COOLER RADIATOR INSTALLATION con't

4. With the hard plastic bumper installed on the vehicle position the CAC radiator with brackets underneath the steel bumper and centered. Mark the four frontmost mounting bracket holes to be drilled. Remove assembly, drill 11/64" holes and install the CAC radiator using four #12 sheet metal screws. (See Fig. 9-d and Fig 9-g).
5. Connect the water pump discharge to the bottom hose barb on the CAC radiator using the supplied 90° hose (and additional straight hose if needed). See Figure 9-f for CAC hose routing.
6. Connect the upper hose barb on the cooler radiator to the water inlet fitting on the CAC core using the supplied hose mender, hose, and a molded 90 degree hose. Drill a hole in the plastic side panel as needed to allow smooth hose routing. (For 300C and Challenger vehicles use the supplied aluminum tube to extend the line into the engine bay above the driver side valve cover as shown in Fig. 9-h).
7. Remove cap from surge tank and slowly fill system with 25%/75% coolant/water mix. Check for leaks.
8. Re-install the front inner and outer fascias and fender liner in reverse of removal.



Fig. 9-g

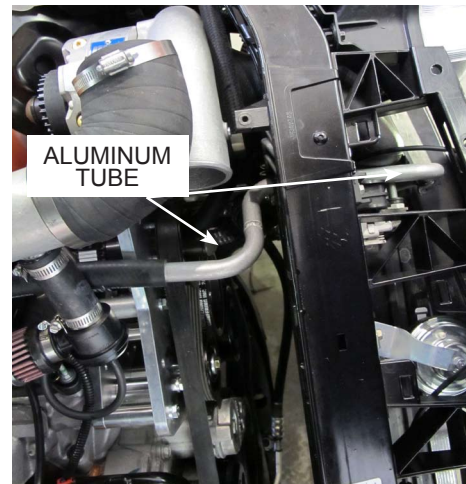

Fig. 9-h (300C/Challenger Only)

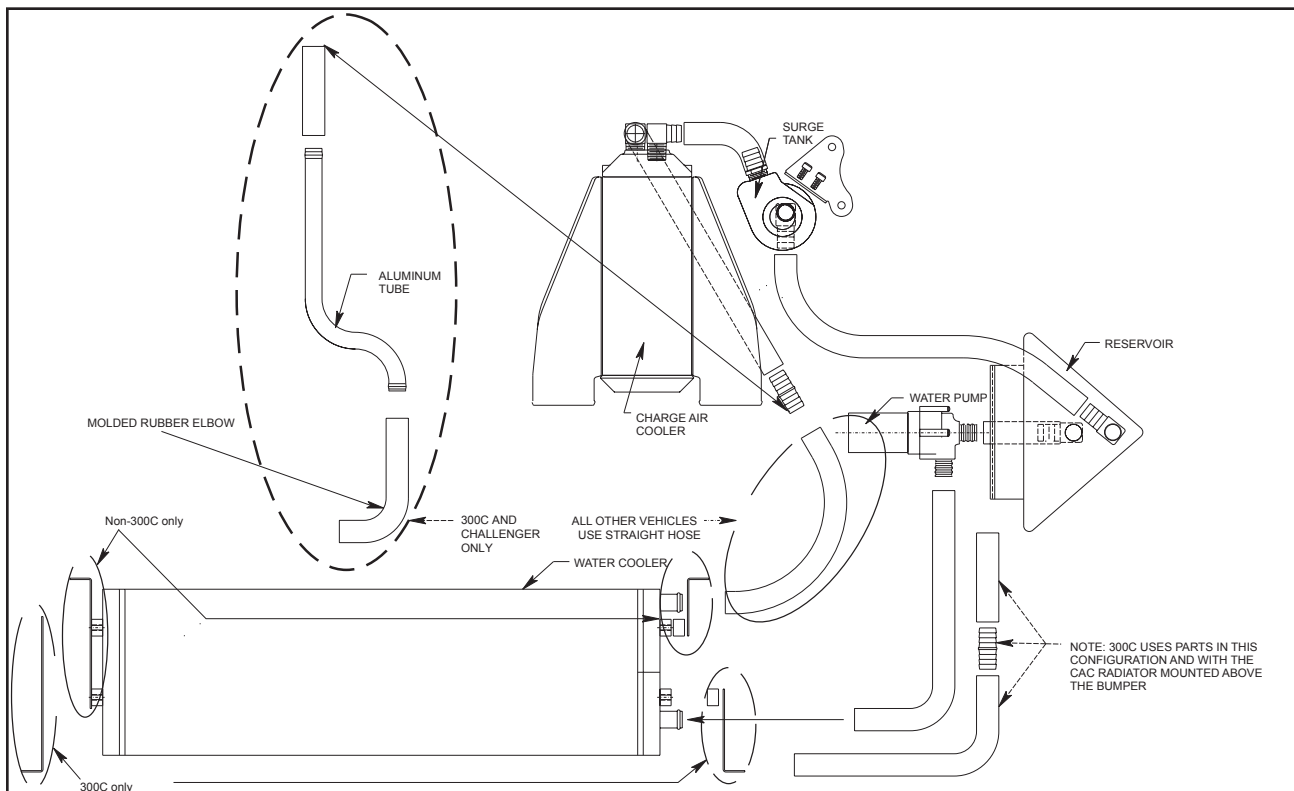

Fig. 9-f

10. SUPERCHARGER DISCHARGE ASSEMBLY INSTALLATION

- A. Attach the straight supercharger discharge tube to the supercharger using the supplied $\text{\O}2.75$ " 90° elbow per Fig. 10-a.
- B. Attach the other end to the CAC inlet using the supplied $\text{\O}2.75 \times 3$ " sleeve and #44 hose clamps.
- C. Install the supplied bypass valve onto the barb on the discharge tube using 1" hose and point it towards the rear of the vehicle. Install the supplied 1" air filter on the bypass valve discharge. (See Fig. 10-b).
- D. Connect $5/32$ " vacuum line from the bypass valve to the tee fitting installed in the brake booster hose in step 3M or 3N. Locate the $5/32$ " tee in the Fuel Pump Voltage Booster assembly and install inline for use in a later step.
- E. **(6.1L engine only)** Re-install the passenger side plastic engine cover. In order to provide room for the charge cooler, remove the oil fill cap, transfer the o-ring on the factory oil fill cap to the supplied oil fill cap and install the supplied oil fill cap.
- F. **(5.7L engine only)** Cut off the driver side portion of the engine cover leaving only a thin portion ($\sim 3/4$ ") extending beyond the colored insert. Loosen the intake manifold bolt and install the supplied "engine cover lower bracket" (see Fig. 10-c).
- G. **(5.7 engine only)** Remove a nut from the driver side rear corner of the colored insert and install the "upper engine cover bracket" (See fig. 10-d).
- H. **(2009-2010 5.7L Challenger only)** Do not re-install the factory engine cover.



Fig. 10-a



Fig. 10-b



Fig. 10-c

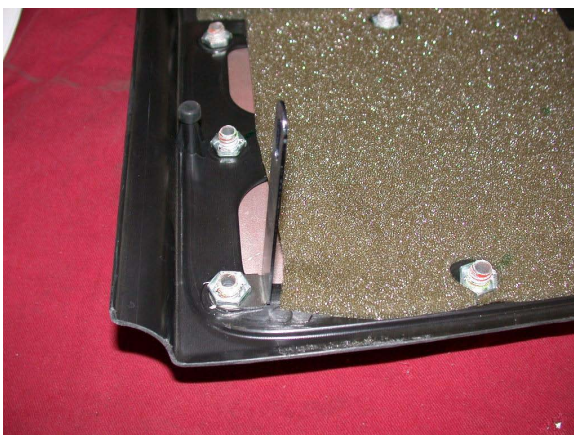

Fig. 10-d

10. SUPERCHARGER DISCHARGE ASSEMBLY INSTALLATION con't

- I. **(5.7L engine only)** Remove a nut from the driver side front corner of the colored insert and install the "front engine cover bracket" onto the underside of the engine cover (See Fig 10-e).
- J. **(5.7L engine only)** Install the engine cover on the passenger side factory pedestals. Using the supplied $\frac{1}{4}$ " hardware connect the "upper bracket" to the "lower bracket" as shown. Slots allow the height to be adjusted as needed.
- K. **(2009-2010 5.7L models only)** Cut the blue w/green wires from the OEM harness approximately 1" from the IAT female connector. Locate the supplied Intake Air Temperature (IAT) harness and cut off the male connector. Slide a piece of supplied heat shrink tubing over each of the OEM IAT wires. Solder the ends of the OEM wires to the new harness (the color of the wires does not matter). Insulate the connections by shrinking the sleeve with the proper amount of heat. Route the wires under the throttle body to the driver's side. Protect the wires with split loom or another suitable means and route them away from heat, sharp edges, and other hazards. Butt connectors have been supplied for temporary connection if a solder joint cannot be completed at installation time.
- L. Install the OEM (2009-2010 5.7L models use the supplied sensor) air temperature sensor into the hole in the discharge tube that connects the CAC outlet to the throttle body using the supplied grommet.
- M. Install the discharge tube using the supplied 90° silicon elbow (if necessary, rotate the engine breather tube so that it does not interfere with the discharge duct).
- N. The IAT sensor wires must be lengthened in order to reach the new IAT sensor mounting location in the discharge duct. If an extension harness is not included use the supplied wire and crimp connectors to accomplish this. (Soldering is recommended).
- O. Plug in the IAT sensor and tighten hose clamps on each connection.
- P. Re-install the front bumper cover using the supplied replacement plastic rivets.



Fig. 10-e

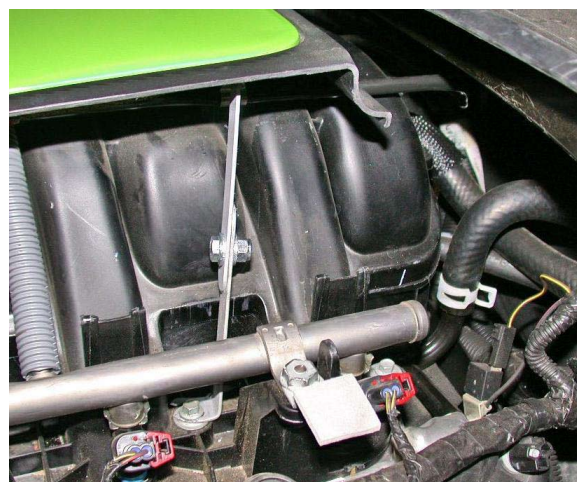

Fig. 10-f



Fig. 10-g

11. FUEL PUMP BOOSTER INSTALLATION (SRT8 AND 2009-2010 5.7L MODELS ONLY. 2006-2008 5.7L SKIP TO SECTION 12)

- A. Open trunk and remove carpet to expose the Styrofoam organizer in the spare tire well and remove the organizer. Using the FPB mounting plate as a template, mark (2) drill hole locations. Using a 17/64" drill bit, drill through, at the two marked locations (see Fig. 11-a).
- B. Secure the supplied FPB to the mounting plate with the provided # 10 hardware screws, washers, and nylock nuts. Then mount the FPB assembly to the two previously drilled 17/64" holes in the spare tire well using the provided 1/4-20 screws, washers, and nylock nuts.
- C. Locate the rubber grommet on the driver's side of the firewall. Make a small slice in the grommet.
- D. Remove the two plastic clips securing the under dash cover. Set aside the cover to be installed in a later step. (See Fig. 11-b)
- E. Lift up the driver side plastic door sill running across the door and remove. (See Fig. 11-c) It will be reinstalled in a later step.
- F. Remove the rear seat by lifting up on each side of the lower section. (The upper section does not need to be removed)
- G. Locate the supplied 1/8" nylon Instrument tubing and install it into the 1/4" plastic split loom.
- H. Route the 1/8" nylon tube assembly along the door sill to the FPB previously installed in the trunk. Secure the loom with provided tie wraps. Locate the 7/64 vacuum hose and cut a 2" piece and install one end on the 1/8" nylon tube and the other end to the vacuum port on the FPB. Secure hose connections with tie wraps. This will be used for boost reference.

NOTE: When routing tubing, ensure nylon tubing does not get kinked or potentially pinched during vehicle operation.

- I. Route the other end of the 1/8" nylon tube assembly loom through the firewall grommet (Previously cut in step 11-C) and into the engine bay. Continue routing the tube assembly to the 5/32" tee fitting installed in the bypass valve line. (Previous step 10-D) Cut another 2" piece of 7/64" vacuum hose and attach to tee fitting. Secure with plastic tie wraps.



Fig. 11-a



Fig. 11-b



Fig. 11-c

11. FUEL PUMP VOLTAGE BOOSTER INSTALLATION con't

- J. Locate the factory fuel pump wires under the rear seat driver's side. Remove the tape from the wires. Separate the blue with orange or blue with red depending on model year (See Fig. 11-d).

NOTE: Crimp on connectors are provided but it is recommended that all of the wire connections be soldered and insulated.

- K. Cut the blue with red/orange trace wire leaving approximately 4" out of the fuel pump. Attach the 12ga. orange wire provided in your kit to the 12ga. orange wire from the FPB. Attach the other end to the fuel pump. This wire will power the fuel pump. (Refer to wiring diagram Fig. 11-h)

NOTE: Refer to the fuel pump wiring diagram that is provided for further explanation if needed (Fig. 11-h).

- L. Attach the 14ga. red wire provided in your kit to the 14ga brown wire from the FPB. Attach the other end to the blue with red/orange trace wire into the OEM wire harness. (Refer to wiring diagram Fig. 11-h)

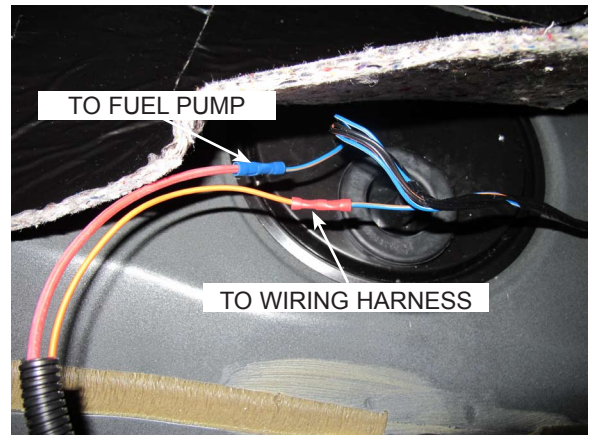

Fig. 11-d

11. FUEL PUMP VOLTAGE BOOSTER INSTALLATION con't

- M. Reinstall the rear seat, door sill, and under dash cover at this time.
- N. On the FPB box, locate the red 12 ga. wire with fuse holder. Cut off the fuse holder and discard. Locate the 12 ga. red wire provided and connect where fuse holder was cut off. Locate the provided black 12ga. wire and connect to the black wire on the FPB.
- O. Route the red power wire and black ground wire toward the fuse box next to the battery. Trim the wires to proper lengths to attach to factory ground lug and factory power distribution box. Locate the provided fuse holder and cut the center of the wire loop. Attach one end to the red 12 ga. power wire from FPB. Use the supplied ring terminals crimp, solder, and attach to factory lugs. (See Figs. 11-e, 11-f, 11-g for close up view.) Install the supplied 40amp fuse into fuse holder after all connections are complete.
- P. Reinstall the trunk organizer and carpet at this time.



Fig. 11-e

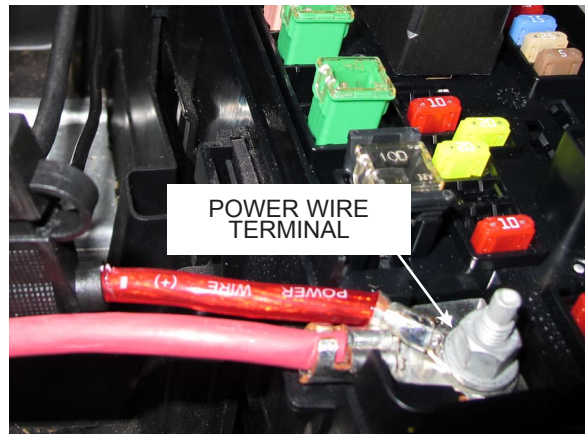

Fig. 11-f



Fig. 11-g

12. REFLASH COMPUTER

IMPORTANT!: To ensure trouble-free programming of your vehicle's computer:

- Make sure the vehicle's battery is sufficiently charged.
- Turn off all accessories & close the doors to prevent unnecessary drain on the battery.
- Do not attempt to program your vehicle while a battery charger is connected.
- Improper battery voltage will result in failure of the programming process.
- Do not disconnect the cable or turn off the ignition during programming.

- A. Reconnect the battery.
- B. With the vehicle off, locate the vehicle's OBD2 connector located below the dash on the driver's side of the vehicle.
- C. Attach the OBD2 connector from the flash tool that is provided in the kit to the vehicle's OBD2 port. Make sure this connector is seated all the way in the vehicle's OBD2 port. You do not want this connector coming out during programming or damage may occur to the vehicle's ECM.
- D. In order to use the inTune, you must select "YES" to agree to the terms set forth by DiabloSport. Once "YES" is selected, the screen will boot and display three parameters. (See Fig. 12-a)
 1. Tune Vehicle
 2. Scan Tool
 3. Settings
- E. Select "Tune Vehicle" by pressing the icon.
- F. You will be prompted to turn the key to the RUN position but do not start the engine. Press "CONTINUE" to proceed.
- G. Select "EASY TUNE".
- H. Next, select "VORTECH HO" and follow the prompts on the screen.
- I. At this point, the inTune will create a backup of your stock tune. Select "YES" to continue. Please allow the inTune to complete this process, which may take a few minutes.
- J. Once the backup is complete, you will be prompted to verify that you want to install the "VORTECH HO" tune. Select "YES".
- K. The inTune will proceed to load the tune at this time. Please allow a few minutes for it to be completed.
- L. Next, you will be prompted to turn the ignition off. Once off, select "CONTINUE".
- M. Next, you will be prompted to turn the ignition to the "RUN" position, but do not start the engine. Select "CONTINUE".
- N. The inTune will now finish loading the tune. Once complete, select "CONTINUE" and unplug the OBD2 cable from the OBD2 port. The tune is now loaded.



Fig. 12-a: inTune Touchscreen Display

13. FINAL ASSEMBLY AND CHECKING

NOTE: THIS SUPERCHARGER HAS BEEN FACTORY PRE-FILLED WITH SPECIAL SYNTHETIC LUBRICANT. OIL DOES NOT NEED TO BE ADDED TO A BRAND NEW UNIT. HOWEVER THE FOLLOWING FLUID LEVEL CHECK SHOULD BE PERFORMED.

- A. Remove the factory installed flat head brass shipping plug (not the dipstick) from the top of the supercharger case.
- B. Replace the sealed shipping plug with the supplied “vented” plug. Do not operate the supercharger without it.
- C. Ensure that the .06” copper sealing washer is located on the dipstick base.
- D. Thread the clean dipstick into the supercharger until it seats.
- E. Once the dipstick has seated, remove the dipstick from the unit. Fluid should register in the crosshatched area on the dipstick.
- F. **DO NOT OVERFILL!!** Drain excess fluid from the unit if it is above the maximum level on the dipstick. Install and tighten the dipstick in the gearcase.
- G. If your vehicle has gone over 20,000 miles since its last spark plug change, it is a good idea to change the spark plugs now, before test-driving.
- H. Make sure that the vehicle is filled with 91 octane or higher fuel before commencing test drive.
- I. With key on, make sure charge air cooler water pump is operating and that water is flowing through the surge tank. Fill as necessary. If water is not flowing, remove the hose from the bottom of the surge tank and lower until water flows out of hose. This should prime the pump. Reconnect hose, verify water flow and top off surge tank. Do not run the water pump for extended periods (30 seconds or more) without water flow.
- J. Check all fittings, nuts, bolt and clamps for tightness.
- K. At this point it is OK to start the vehicle.

WARNING: DO NOT ATTEMPT TO OPERATE THE VEHICLE UNTIL ALL COMPONENTS ARE INSTALLED AND ALL OPERATIONS ARE COMPLETED INCLUDING FINAL CHECK. FAILURE TO DO SO MAY CAUSE PREMATURE FAILURE OF MAJOR COMPONENTS.

- L. With engine running, check power steering hose connections for leakage. Let engine run for two minutes. Turn steering wheel in both directions.



Fig. 13-a



Fig. 13 -b

13. FINAL ASSEMBLY AND CHECKING con't

Verify:

- Smooth power assist
 - Noiseless operation
 - Proper fluid level
 - No system leaks
 - No bubbles, foam or discoloration in fluid
- M. Verify that the gilmer belt is running smoothly. If wear is detected on the side of the belt, it is probably too tight. If it is vibrating excessively, tighten until there is minimal movement.
- N. Turn off vehicle and recheck all fluid levels and verify that no hoses, wires, etc. are near exhaust headers or moving parts and that there is no fluid leakage.
- O. Re-install the splash pan.
- P. Test drive vehicle by gradually working up to full throttle and paying close attention to any abnormal sounds or engine detonation.
- Q. Install the engine cover by trimming the driver side to clear the supercharger kit.
- R. Read the STREET SUPERCHARGER SYSTEM OWNER'S MANUAL AND RETURN THE WARRANTY REGISTRATION FORM within thirty (30) days of purchasing your supercharger system to qualify for the 3 year limited warranty.

WARNING: NEVER OPERATE YOUR ENGINE AT FULL THROTTLE WHEN THE ENGINE IS COLD. ALWAYS ALLOW PLENTY OF TIME FOR THE OIL TO REACH FULL OPERATING TEMPERATURE BEFORE RUNNING ABOVE 2,500 RPM. FULL SUPERCHARGER OPERATING TEMPERATURE IS GENERALLY ACHIEVED ONLY AFTER THE ENGINE WATER TEMPERATURE HAS BEEN AT THE NORMAL INDICATED OPERATING RANGE FOR TWO OR THREE MINUTES.

V3 supercharger long term maintenance and care:

- **CAUTION:** Use of any fluid other than the Vortech supplied synthetic lubricating fluid will void the warranty and may cause component failure.
Replacement Vortech SL lubricating fluid part numbers:
009035: Package of three 4 oz. bottles
 - Check the fluid level using the dipstick at least every 2,500 miles.
 - Initial supercharger fluid change must be performed at 2,500 miles. The supercharger fluid must then be changed at least every 7,500 miles.
1. Drain the fluid, re-fill the unit only with 4 oz. of Vortech supplied synthetic lubricating fluid.
 2. Confirm proper oil level using the dipstick. **DO NOT OVERFILL!!** (See steps 13-C through 13-F)



ENGINEERING, INC

1650 PACIFIC AVENUE • CHANNEL ISLANDS, CA 93033-9901 • (805) 247-0226
FAX (805) 247-0669 • www.vortechsuperchargers.com • M-F 7:00 AM - 3:30 PM PST