

EVAKOOL®

TRAVELMATE XTREME

INSTRUCTION MANUAL

FOR MODELS

TMX35

TMX50

TMX65

TMX75



CHILLED FOR GOOD TIMES

Please read operating manual carefully before using your unit.

Please keep manual in a safe place.

If lost find a digital copy at Evakool.com.au or contact Evakool on 1300 385 665 (1300 EVKOOL).

Contents

1	Safety Instructions	4
2	Notes on Using the Product	4
3	Operation	5
4	Cleaning & Maintenance	8
5	Troubleshooting	8
6	Error Codes	9
7	Warranty Statement	10

Key Product Features

- Reliable cooling system - SECOP compressor.
- Efficient electronic technology, low energy consumption.
- Multi-voltage system (DC 12-24 Volt) and (AC 100-120/220-240 Volt).
- Digital Battery Protection - protects your vehicle battery effectively.



NOTE

Your fridge is preregistered with the following user account for the APP.

User: 12345678900

Password: 123456

1 Safety Instructions

- Warning: Do not touch exposed cables.
- Warning: Do not use fridge if you suspect any connections could be wet.
- When using the fridge please ensure the circuit being used is fused.
- Any installation of DC power sources should be handled by a qualified professional.
- Make sure the source voltage is correct. The technical data label shows the voltage data.
- Do not place any electrical devices inside the refrigerator as moisture could harm these devices.

2. Notes On Using The Product

- Your refrigerator requires good ventilation, especially around the vents of the refrigerator; allow a gap of at least 200mm around the vents and 100mm around the rest of the unit.
- Avoid humidity: humidity inside the appliance can form frost and impair cooling. Do not allow frost to build up.
- Never wash the appliance using a hose or running water and never submerge the unit, as water will damage the electronics.
- Avoid placing your refrigerator near a heat source. A cooler environment helps the refrigerator to work more efficiently and keep the contents cool.
- Place the refrigerator on a flat surface and away from any edges. When using the fridge in a vehicle, please use a fastening device to secure it.

3. Operation

- **Power:** The refrigerator can be powered by a multi-voltage system utilising either 12/24 Volts or 240 Volts. The electronic module controls the compressor motor and has the added function of a three stage battery protection. When the input voltage drops below the minimum, the compressor will cut out; when the voltage comes back up to the cut-in value, the compressor will restart automatically.
- **Battery Protection:** The Secop compressor requires over 10.4 Volts (12 Volt System) or 23.0 Volts (24V System) to operate. If the voltage drops below this the fridge will stop operating.
- **Cable Specification:** The DC cables must have a suitable cross-section for their length (measured from the battery to the unit), according to this table:

Cable Thickness (Area)		12V Max Cable Length		24V Max Cable Length	
(mm ²)	AWG	(m)	(ft)	(m)	(ft)
2.5	12	2.5	8	5	16
4	12	4	13	8	26
6	10	6	20	12	39
10	8	10	33	20	66

Display Panel

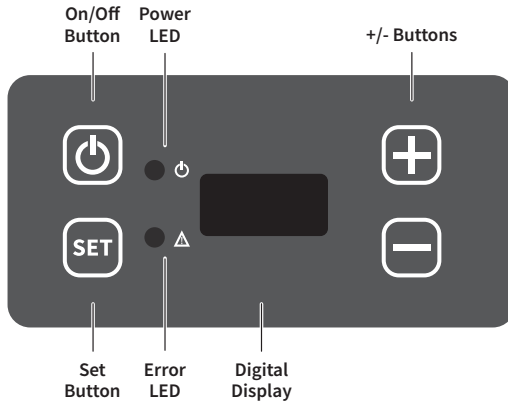

Using the Fridge

- **To Turn On:** Plug in the DC or AC power cable. The LED display on the control panel will light up and the interior temperature will be displayed.
- **Note:** If the unit is off, only an orange LED will be illuminated. To turn on your unit please hold the  button down until the power LED changes to green and the LED display is illuminated.
- **Setting the Temperature:** Press **SET** once and then the display will flash then press the **+** and **-** buttons to adjust the temperature. Press the button **+** to increase and the button **-** to decrease the temperature. The temperature will flash three times before automatically setting in place. The display board will display the current temperature inside the unit after the target temperature is set. After approximately 5 minutes the displayed temperature will start to decrease.
- **Temperature setting range:** -20°C to +10°C, 4°F to +50°F.
- To change the fridge between °C a °F. Press **SET** twice and then **+** or **-** to change the setting. Press **SET** again to lock this in.
- **Changing battery voltage protection:** To change the battery voltage setting press the **SET** button three times and then use the **+** or **-** to change the setting. Press **SET** once to lock this in. The three voltage settings are as follows: (Evakool recommends you keep the setting on LO).

LO – 10.4 Volts

NE – 11.2 Volts

HI – 12 Volts

USB Charging Port and Thermostat Override Switch



USB Port

- USB Port – This USB port can be used to charge small devices. E.g. mobile phones and remote controllers. The socket is rated to 500mA / 5 Volts.

Thermostat Override Switch

- If your digital thermostat fails and you are unable to set the temperature, turn this switch to Emergency override. This enables the fridge to run until you reach a service centre to replace the faulty component.
- If emergency override is enabled the compressor will run 100% of the time. As this removed the ability to set the internal temperature and will increase power usage and cause product to freeze, it is not recommended for everyday use.

4. Cleaning & Maintenance

- Clean the appliance inside and out with a damp cloth every week. If it is dirty, use sodium bicarbonate dissolved in lukewarm water to clean the unit.
- Never use abrasive products, detergents or soap. After washing, rinse with clean water and dry carefully. Do not leave the refrigerator off with food inside or lid closed.
- Never clean the appliance under running water. Do not use abrasive cleaning agents or hard objects during cleaning as these can damage the refrigerator.

5. Troubleshooting

The appliance is not turning on

- Check the power supply.
- Check whether the plug and the socket have a good connection.
- Check whether the fuse has been burned out.
- Check whether the appliance has been turned on (Press and hold ON/OFF button).

The food inside is frozen

- The setting temperature is too low.
- Thermostat override switch is enabled.

Bad performance in refrigeration

- Too much food been placed inside the refrigerator.
- The lid is unlocked/or open.
- The lid seal is broken.
- Problems arising from poor ventilation.
- There is too much warm product inside.
- There is no room around the fridge and vents.
- There is a heat source near the unit.
- The temperature setting is inappropriate.

Hear the sound of water from inside the unit

- This is normal, due to the flow of the refrigerant.

Unusual noise when refrigerator is working

- The refrigerator is not placed on a level surface.
- Some part has come loose inside the refrigeration compartment (see a service agent).

If none of the above solves your issue please contact Evakool on 1300 385 665 or warranty@evakool.com for details of your closest Evakool service centre.

6. Error Codes

The error codes are depicted by a number of flashes by the error light in a sequence every four seconds.

Code	Reason / Solution
ERR1 or ERR2 (On Display instead on temperature)	<p>Faulty temperature probe</p> <ul style="list-style-type: none"> • Please call Evakool for closest service centre.
1 Flash	<p>Low Voltage</p> <ul style="list-style-type: none"> • Please check the source voltage to ensure it is above the cut out. Try lowering the voltage cut out setting to LO. • The vehicle cabling may be inadequate/unsuitable, please refer to cable specifications table for correct cable thickness (page 5). • Try on a different power source.
2 Flashes	<p>Fan or compressor running issue</p> <ul style="list-style-type: none"> • Fan is drawing too many Amps (Over 1 Amp) –Replace Fan. • The compressor is drawing too many amps (Over 12 Amps). • Possible Electronic Box or compressor fault – contact Evakool or Service Agent.
3 Flashes	<p>The compressor speed is too low</p> <ul style="list-style-type: none"> • Reduce products / items inside unit. • Move unit to a lower ambient temperature. • Clean vents / ensure clear air flow over compressor.
4 Flashes	<p>Ambient Temperature too high</p> <ul style="list-style-type: none"> • Clean vents / ensure clear air flow. • Fan Fault – Replace fan.
5 Flashes	<p>Thermal Cut-Out of Electronic Unit</p> <ul style="list-style-type: none"> • If the refrigeration system has been too heavily overloaded. • Ambient temperature is too high.

7. Warranty Statement/Terms & Conditions

Nexberg Pty Ltd trading as EvaKool undertakes to the original purchaser that this product is sold free of defect in materials and/or workmanship under normal use for a period of **36 months (as of 2020)**. Subject to the following:

- The warranty period commences from the date of purchase by the original purchaser from an authorised EvaKool dealer.
- The Secop compressor in this unit carries a 5 year warranty under normal use.
- EvaKool will honour this warranty on presentation of proof of purchase of the unit to EvaKool or its approved service agent. The service agent may be requested to provide EvaKool with a photocopy of the proof prior to warranty being honoured.
- EvaKool will not be held responsible for any costs incurred in making a warranty claim.
- Please telephone 1300 865 665 for the name of an authorised service agent or refer to list provided on website. It is the purchaser's responsibility to freight the unit to and from the service agent.
- EvaKool will not be held responsible for any damage or loss suffered or cost incurred whilst fridge is in transit.
- Warranty repairs may only be carried out by an authorised service agent. EvaKool will not reimburse repair claims carried out by unauthorised service agents. Any unauthorised tampering with any part of the unit will automatically void the warranty.
- Service agents may charge a fee for viewing or testing the unit. This is not covered by EvaKool or this warranty and is payable at the service point unless authorised by EvaKool.
- Any EvaKool authorised service centre in Australia will be able to carry out the service of your unit. If a repair needs to be undertaken and is covered in terms of this warranty a warranty authorisation number must be obtained prior to commencement of any work.
- This warranty does not extend to any products acquired for the purposes of re-supply, to be used up or transformed in a production or manufacture process or in repairing other goods.
- This fridge is intended for recreational use only. If used for commercial use, a 12 month warranty applies.
- To the extent permitted by law, this warranty does not extend to any claim for damages that you or any other person may have for any loss (including without limitation consequential damages or loss of profit) or damage howsoever caused.
- **EvaKool will not accept a warranty claim if:**
 1. Modifications have been carried out to the unit without EvaKool's written authority.
 2. Damage to or failure of the unit has been caused in EvaKool's opinion by incorrect, extreme or unreasonable use.
 3. Damage to or failure of the unit has been caused in EvaKool's opinion by misuse, neglect, accident, impact or similar cause. Refer the preventative maintenance guidelines.
- EvaKool has total discretion of the variation of the warranty terms.
- Our goods come with guarantees that cannot be excluded under the Australian Consumer Law. You are entitled to a replacement or refund for major failure and for compensation for any other reasonably foreseeable loss or damage. You are also entitled to have the good repaired or replaced if the goods fail to be of acceptable quality and the failure does not amount to a major failure.
- The above warranty conditions are in addition to any other rights and/or remedies as per the applicable law.
- Failure to follow the guidelines/recommendations in this manual may void the warranty.
- This warranty cannot be varied by others.

Please retain your receipt or proof of purchase for warranty purposes.

EVAKOOL®

CHILLED FOR GOOD TIMES

For your nearest stockist contact EvaKool

T: 1300 385 665 (1300 EVKOOL)

E: warranty@evakool.com

or visit us at evakool.com.au