

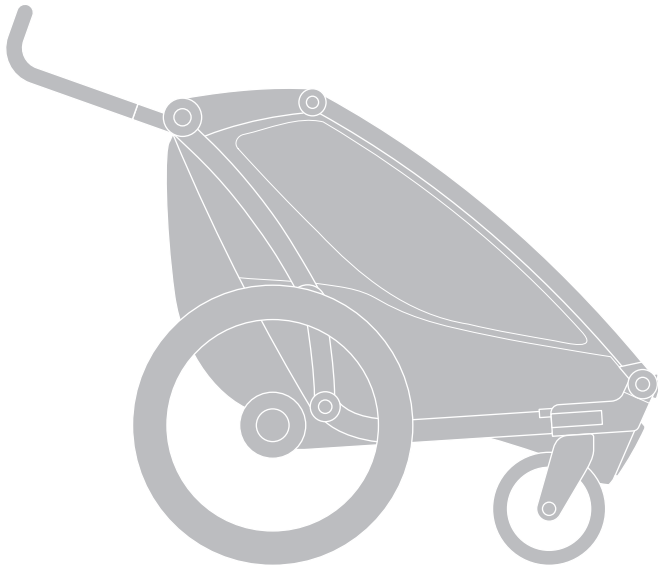

> Instructions

Thule Chariot Lite 1 & 2

102030XX



- EN** Multisport trailer
- DE** Mehrzweck-Anhänger
- FR** Multi-purpose trailer
- NL** Multifunctionele fietskar
- ES** Remolque para bicicleta multifuncional
- PT** Trailer multiesportivo
- IT** Rimorchio multiuso
- SV** Multisportvagn
- DK** Multisportstrailer
- NO** Flerfunksjonsvogn
- FI** Monikäyttötöperävaunu
- IS** Margnota tengivagn
- ET** Universaalsed kârud
- LV** Daudzfunkcionāla piekabe
- LT** Universalioji priekaba
- RU** Универсальный прицеп
- UK** Багатофункціональний причеп
- PL** Wielofunkcyjna przyczepka

- CS** Multifunkční přívěs
- HU** Többfunkciós utánfutó
- RO** Remorcă multifuncțională
- SK** Viacúčelový príves
- SL** večnamenski voziček
- BG** Многофункционално ремарке
- HR** Multifunkcionalna prikolica
- EL** Τρέιλερ πολλαπλών χρήσεων
- TR** Çok amaçlı dorse
- MT** Trejler b'ħafna użi

נגרר רב-תכליתי **HE**
 مقطورة متعددة الاستخدام **AR**

- ZH-CN** 多用途拖车
- ZH-TR** 多功能拖車
- JA** 多目的トレーラー
- KO** 다목적 트레일러
- TH** รถพ่วงอเนกประสงค์
- MS** Treler berbilang fungsi

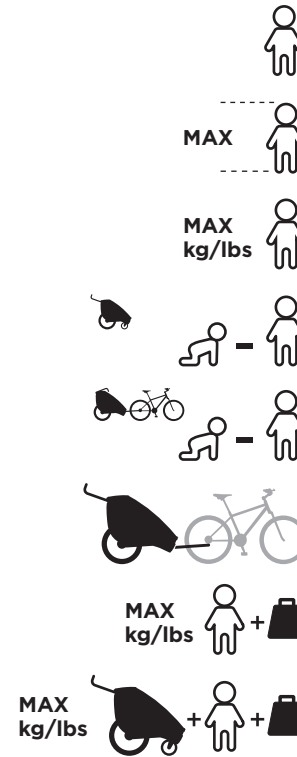

Thule Chariot Lite 1	Thule Chariot Lite 2
111 cm 44 inch	111 cm 44 inch
22 kg 49 lbs	22 kg x 2 49 lbs x 2
6 m - 4 y	6 m - 4 y
1 - 4 y	1 - 4 y
12,6 kg 27.8 lbs	13,9 kg 30.7 lbs
34 kg 75 lbs	42 kg 92.6 lbs
50 kg 110 lbs	60 kg 132 lbs

- EN** *Whichever comes first
- FR** *N'importe lequel
- ES** *Lo que ocurra primero
- DE** *Je nach dem, was zuerst kommt
- NL** *Afhankelijk van wat zich het eerst voordoet
- PT** *O que vier primeiro
- IT** *A seconda di quale si verifica prima
- SV** *Beroende på vad som infaller först
- DK** *Uanset hvilken, der kommer først
- NO** *Det som skjer først
- FI** *Kumpi tapahtuukaan ensin
- IS** *Sama hvort gerist fyrst
- ET** *Kumb on varasem
- LV** *Neraugoties uz to, kurš ir pirmais
- LT** *Atsižvelgiant į tai, kas įvyksta pirmiau
- RU** *Смотря что наступит ранее
- UK** *Залежно від того, що настане раніше
- PL** *w zależności które zostanie przekroczone jako pierwsze

- CS** *Cokoliv, co přijde dříve
- HU** *Amelyik előbb történik
- RO** *Oricare se realizează mai întâi
- SK** *Podľa toho, čo nastane skôr
- SL** *Kar je izpolnjeno prej
- BG** *Коего е първо
- HR** *Ovisno o tome što nastupi prije
- EL** *Όποιο έρθει νωρίτερα
- TR** *Hangisi önce gerçekleşirse
- MT** *Ikun liema jkun li jiġi l-ewwel

המוקדם מביניהם **HE**
 * أيهما يأتي أولاً **AR**

- ZH-CN** *以先到达者为准
- ZH-TR** *先到者優先
- JA** *どちらでも、早い方を
- KO** *이 가운데 먼저인 것
- TH** *แล้วแต่อย่างใดก่อน
- MS** *Mana satu dahulu

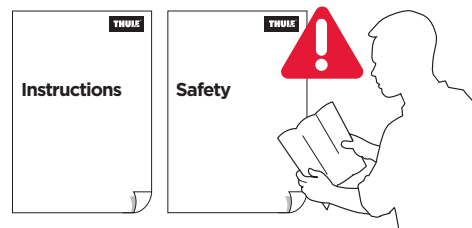

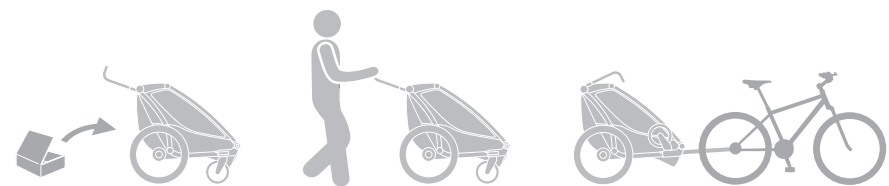

6-10	!
12	EN
14	FR
16	ES
18	DE
20	NL
22	PT
24	IT
26	SV
28	DK
30	NO
32	FI
34	IS
36	ET
38	LV
40	LT
42	RU
44	UK
46	PL
48	CS
50	HU
52	RO
54	SK
56	SL
58	BG
60	HR
62	EL
64	TR
66	MT
68	HE
70	AR
72	ZH
74	ZH
76	JA
78	KO
80	TH
82	MS
84-109	

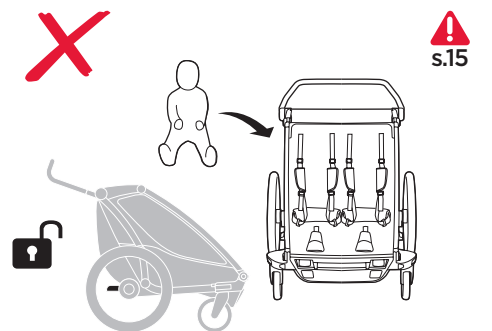
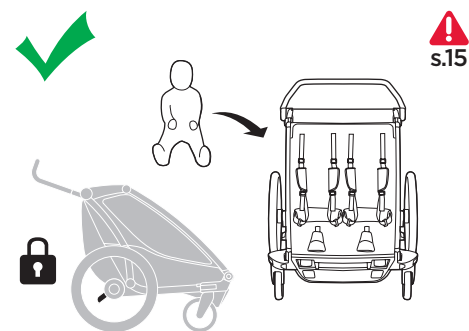
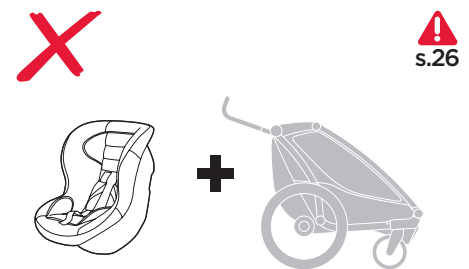
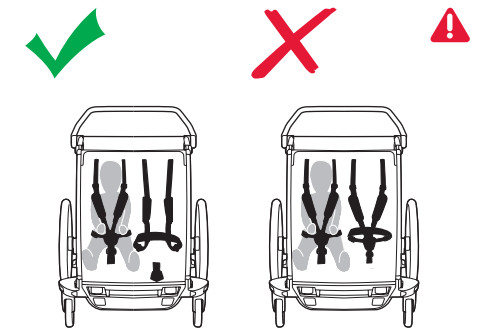
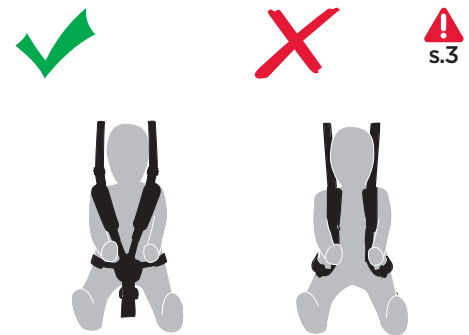
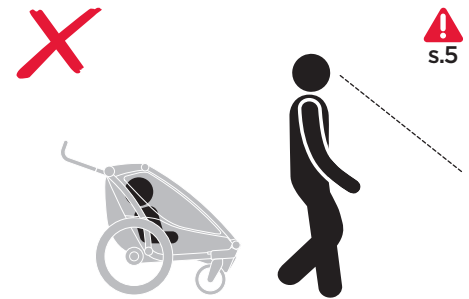
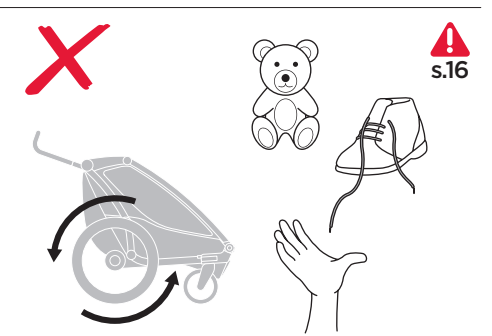

i

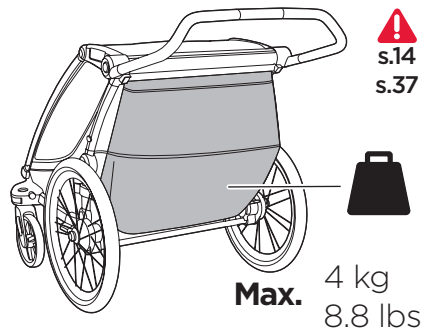
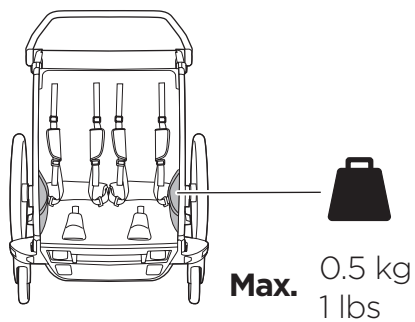

!
s.14
s.37

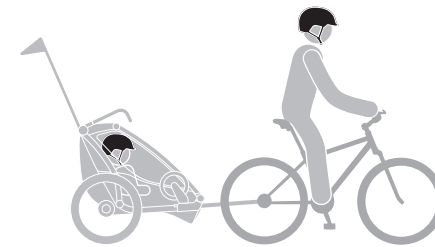
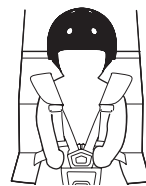

!
s.23
s.40



s.46

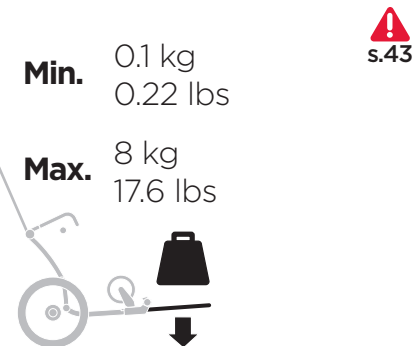
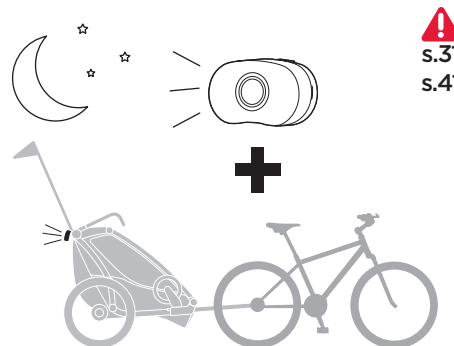
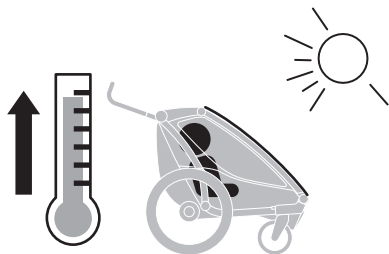

s.13

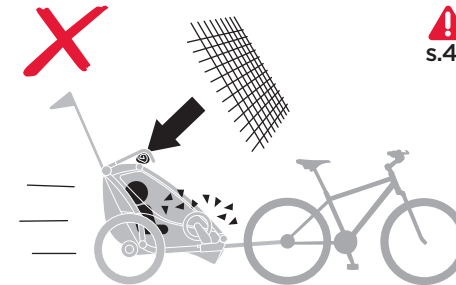
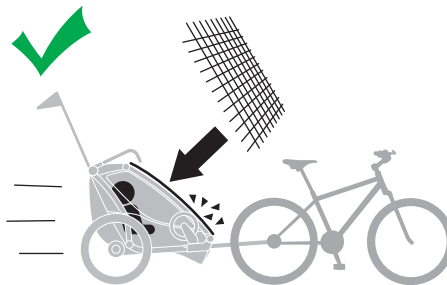
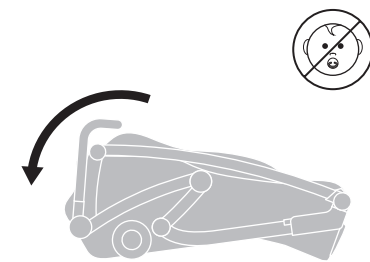
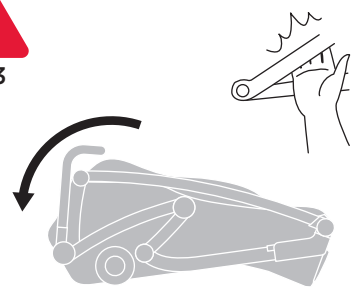

i

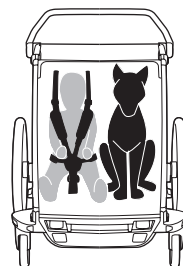
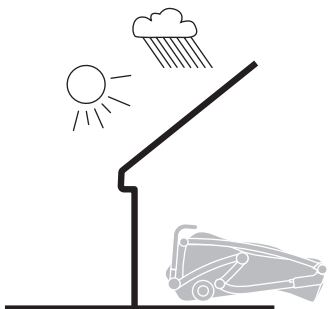

!
s.32

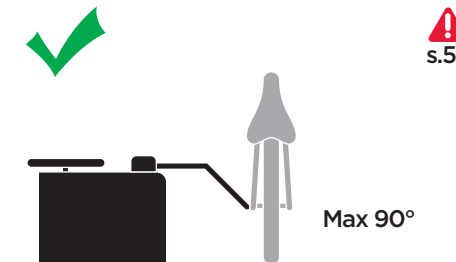
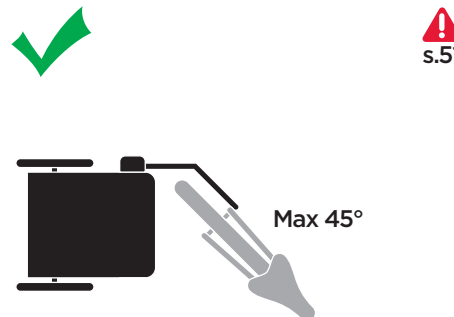



s.38
s.42

Max. 25 km/h
15 mph

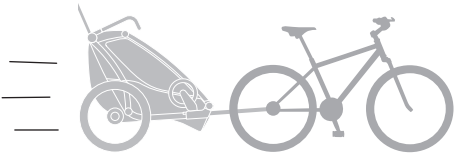

s.50

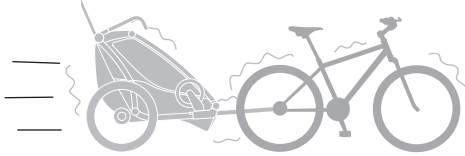

s.58

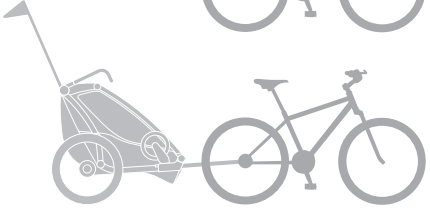
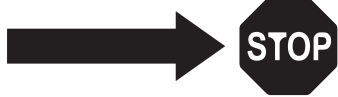

s.44

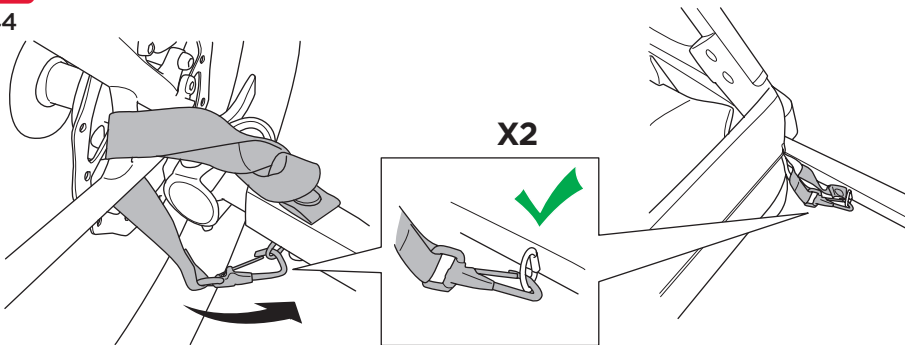

s.27



Features

1. Adjustable handlebar
2. Sunshade
3. Weather and mesh covers
4. Reflectors
5. Adjustable vents
6. Bike arm
7. Push button fold
8. Adjustable suspension
9. Stroller wheel storage
10. Versawing
11. Bike arm storage / Fold lock
12. Wheel release button
13. Reflective tires
14. Wrist strap
15. Accessory cross bar
16. Mesh pocket
17. Parking brake pedal

! WARNING

IMPORTANT - READ CAREFULLY AND KEEP FOR FUTURE REFERENCE. The child's safety may be affected if you do not follow these instructions.

Read the Safety manual for Thule Strollers and Bicycle Trailers before use and keep for future reference.

Maintenance

Keeping this Thule child carrier clean and well maintained is an important factor in keeping it in good condition.

It is highly recommended that you take your child carrier to an authorized service provider once a year to keep it in the best possible condition.

Regularly inspect your Thule child carrier and accessories for damage and signs of wear:

- Check metal components for any dents or cracks. Do not use the child carrier if any metal components are cracked or damaged.
- Examine the child carrier to see if any of the fasteners are bent, broken, missing or loose. Tighten any loose fasteners and replace any damaged or missing fasteners.

- Examine the fabric regularly for tears, worn spots or any other signs of damage.

Regularly clean the child carrier with warm water and a mild soapy solution. Never use harsh cleansers or solvents.



Clean the wheel axles and apply grease or oil to all exposed moving parts. Have the wheels inspected and serviced at least once a year.

Store your child carrier and accessories in a dry area out of direct sunlight.

Before storing your child carrier, it should be dry to prevent the growth of mold or bacteria.

Accessories

Thule offers several accessories that are compatible with your child carrier. Contact your local dealer or visit www.thule.com for more information.

Contact

We are always interested to get your feedback and answer your questions on our products to make sure we give the best experience possible. Please contact our consumer service via support.thule.com or contact your local dealer.

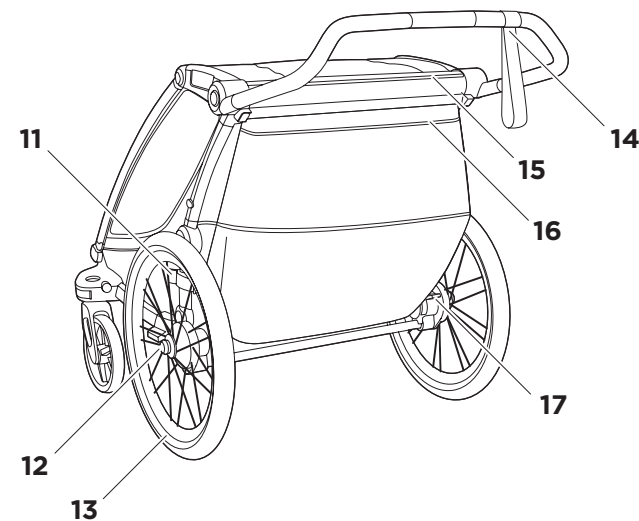
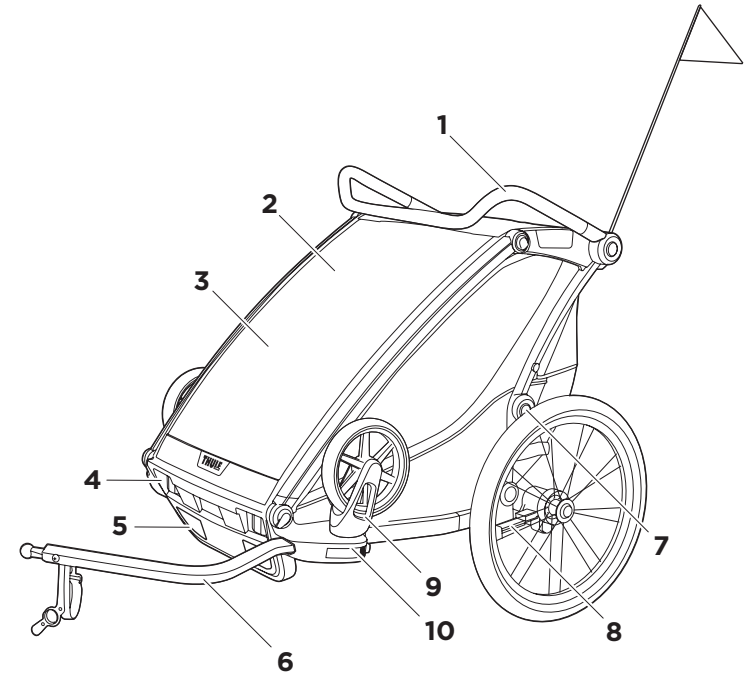

Caractéristiques

1. Guidon réglable
2. Pare-soleil
3. Toile et filet de protection
4. Réflecteurs
5. Évents réglables
6. Bras de fixation
7. Pliage par bouton-poussoir
8. Suspension réglable
9. Stockage au niveau des roues de la poussette
10. Versawing
11. Verrouillage/Stockage du bras de fixation
12. Bouton-poussoir roue
13. Pneus réfléchissants
14. Dragonne
15. Barre transversale pour accessoire
16. Poche en filet
17. Pédale du frein de stationnement

⚠️ AVERTISSEMENT

IMPORTANT - LISEZ ATTENTIVEMENT CES INSTRUCTIONS ET CONSERVEZ-LES POUR RÉFÉRENCE ULTÉRIEURE. Leur non-respect pourrait compromettre la sécurité de votre enfant.

Lisez le manuel de sécurité des poussettes et remorques de bicyclette Thule avant de les utiliser et conservez-le pour référence ultérieure.

Entretien

Pour maintenir la remorque pour enfant Thule en bon état, il est important de la garder propre et de bien l'entretenir.

Il est fortement recommandé d'apporter la remorque pour enfant dans un centre de services autorisé une fois par an afin de la maintenir dans le meilleur état possible.

Inspectez régulièrement votre remorque pour enfant Thule et les accessoires pour vous assurer qu'ils ne montrent aucun signe de détérioration ou d'usure :

- Vérifiez que les pièces métalliques ne sont ni bosselées ni fissurées. N'utilisez pas la remorque pour enfant si les pièces métalliques sont fissurées ou endommagées.

- Examinez les attaches de la remorque pour enfant afin de vous assurer qu'elles ne soient ni pliées ou brisées, ni manquantes ou desserrées. Resserrez les attaches desserrées et remplacez celles qui sont endommagées ou manquantes.
- Vérifiez régulièrement que le tissu ne présente pas de déchirures, d'usure ni d'autres signes de détérioration.

Nettoyez régulièrement la remorque pour enfant avec de l'eau tiède et un savon doux. N'utilisez jamais de détergents puissants ni de solvants.



Nettoyez les essieux de roue et appliquez de la graisse ou de l'huile sur les pièces mobiles visibles. Les roues doivent être inspectées et entretenues au moins une fois par an.

Rangez votre remorque pour enfant et vos accessoires dans un endroit sec à l'abri de la lumière directe du soleil.

Avant le rangement, votre remorque pour enfant doit être sèche afin d'éviter le développement de moisissures ou de bactéries.

Accessoires

Thule propose de nombreux accessoires compatibles avec votre remorque pour enfant. Pour de plus amples informations, contactez le revendeur le plus proche ou visitez notre site Web : www.thule.com.

Contact

Nous sommes constamment désireux de connaître votre avis et de répondre à vos questions sur nos produits pour vous offrir la meilleure expérience possible. Contactez notre service clientèle via le site support.thule.com ou votre revendeur.

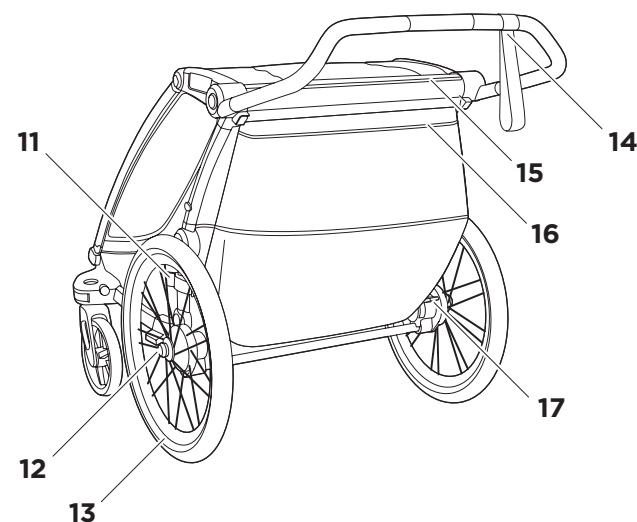
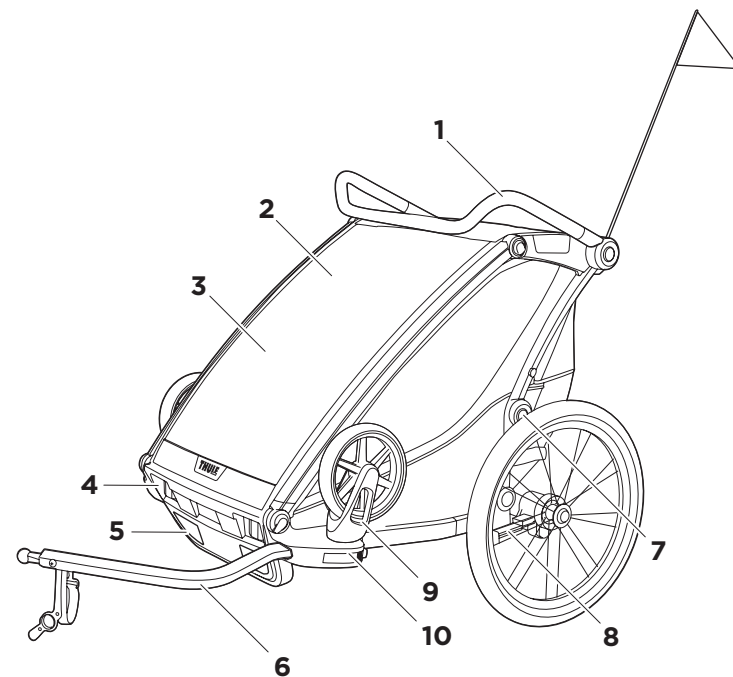

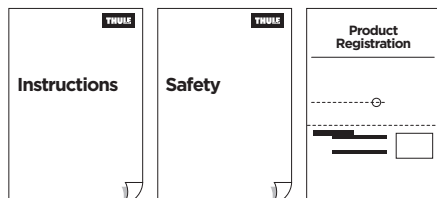
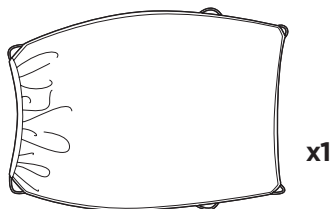
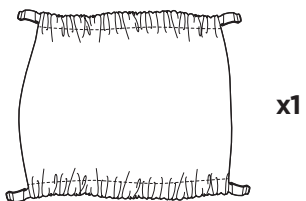
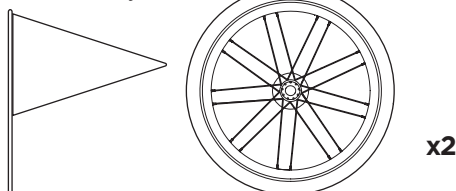
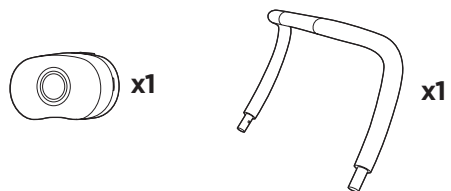
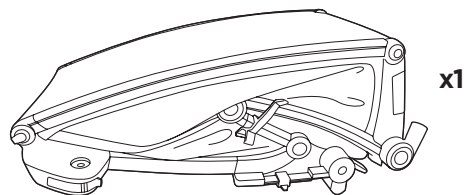

www.thule.com/register

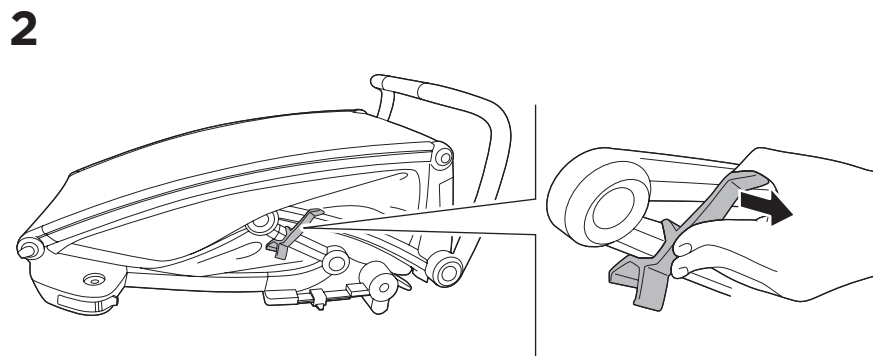
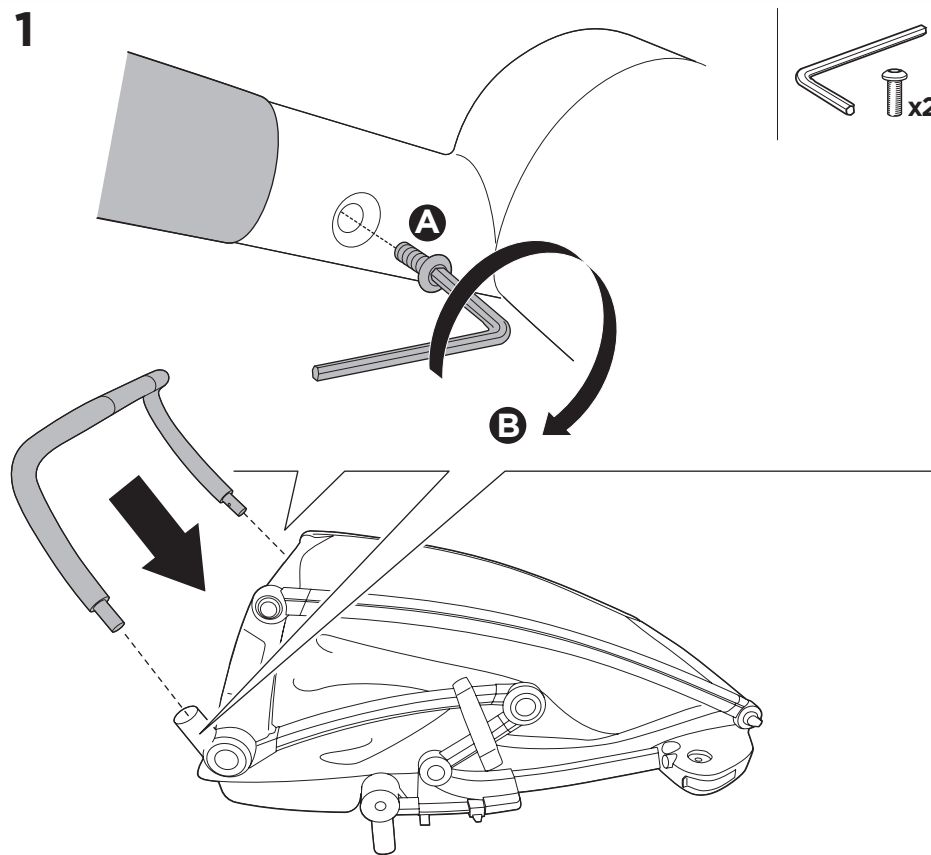
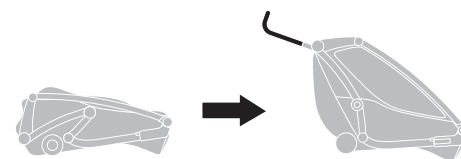
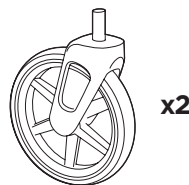
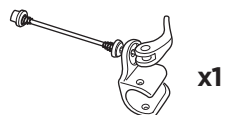
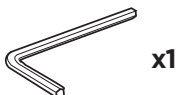

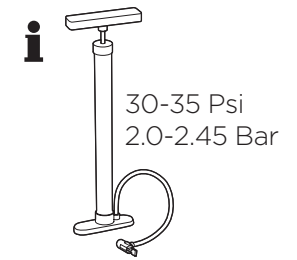
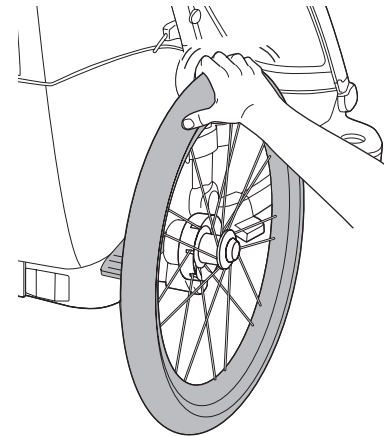
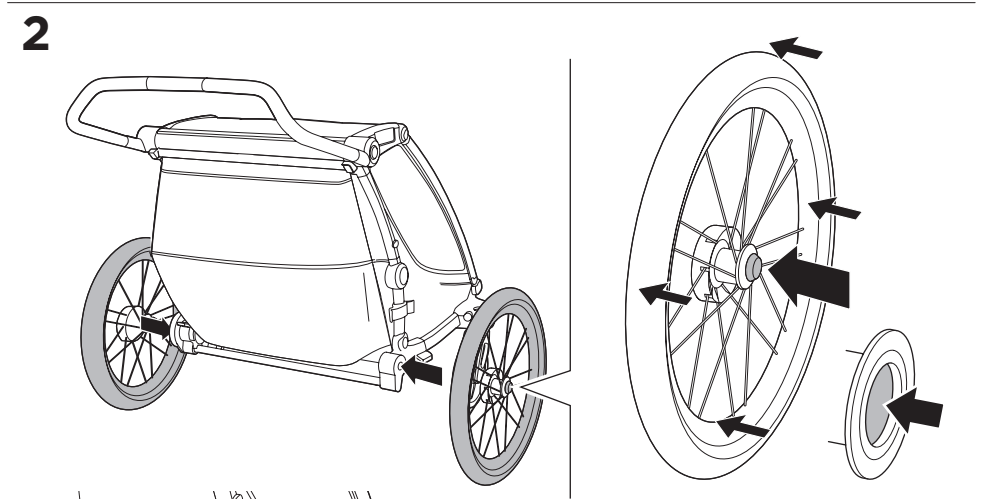
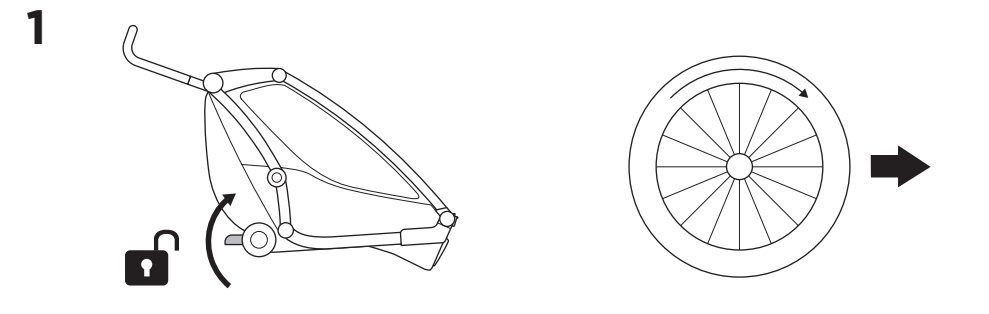
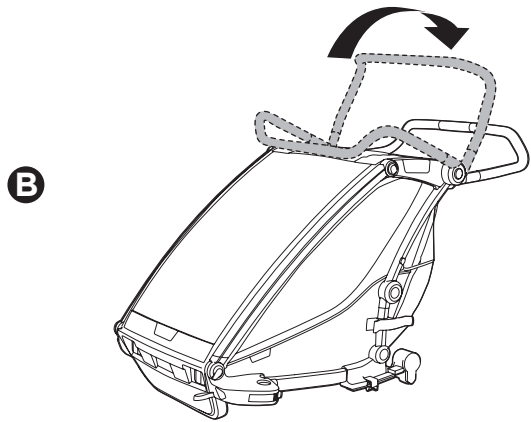
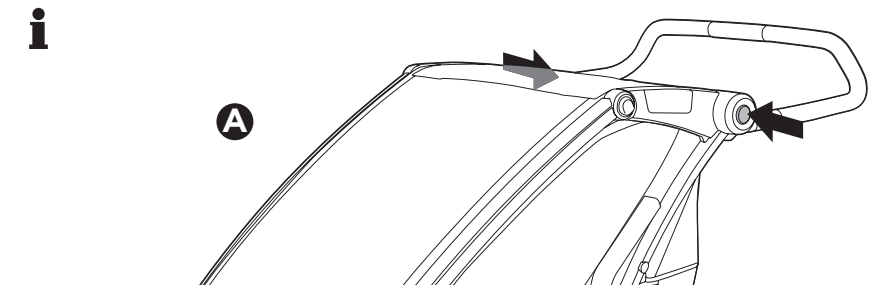
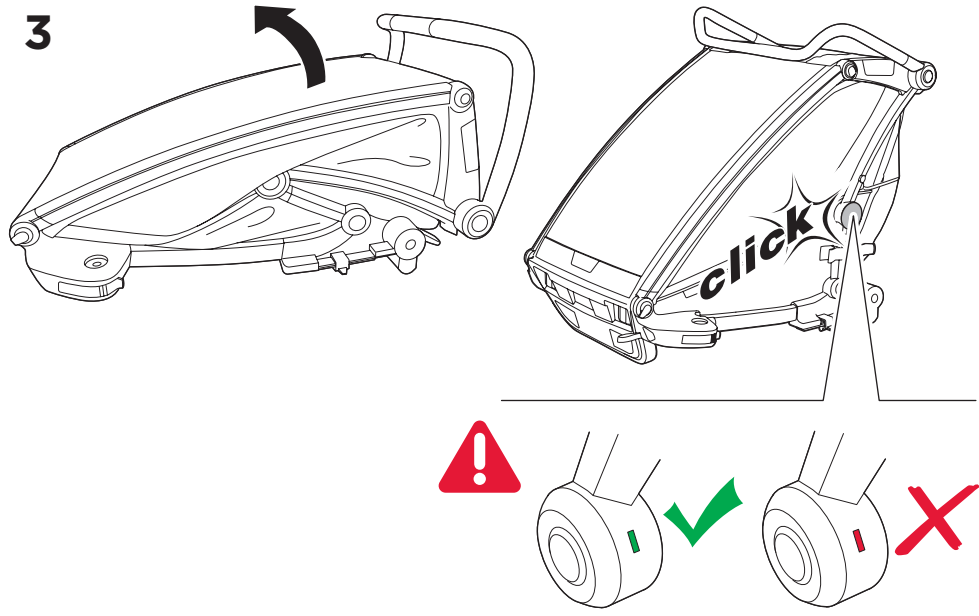



1

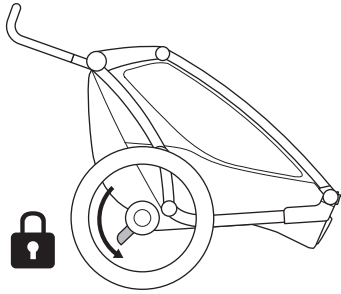

2

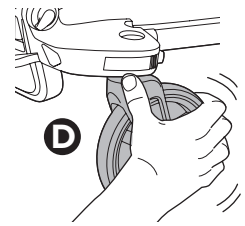
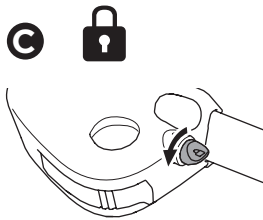
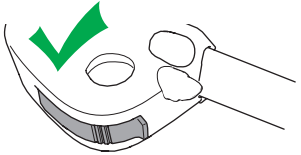
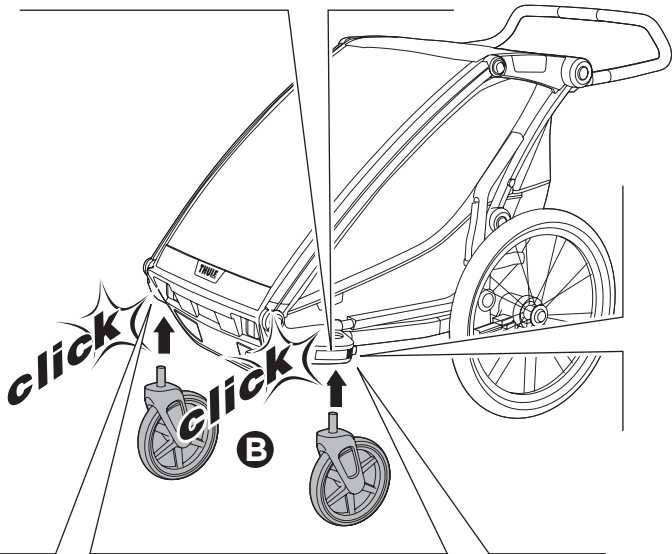
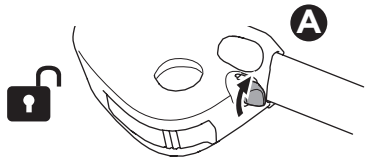

5561469001



STOP

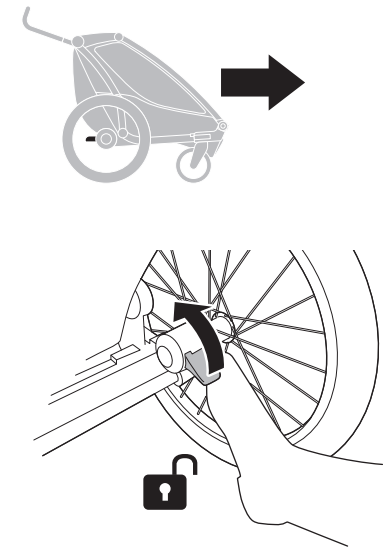
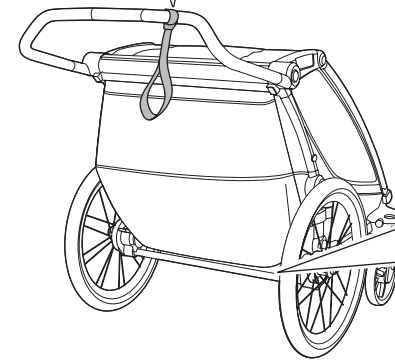
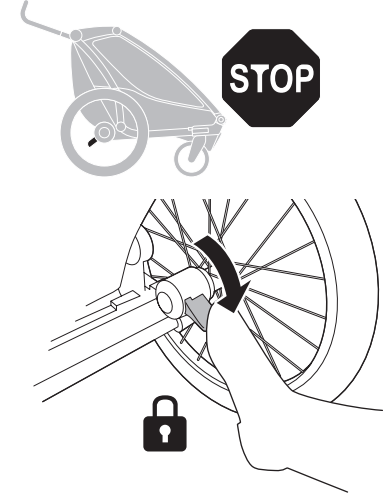
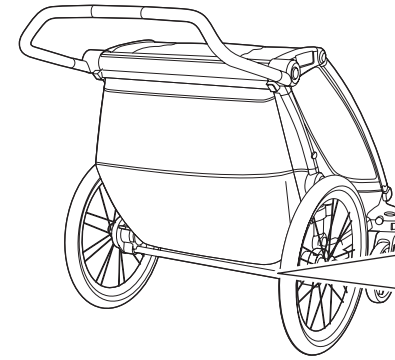
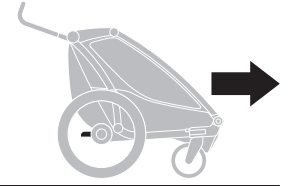

5561469001

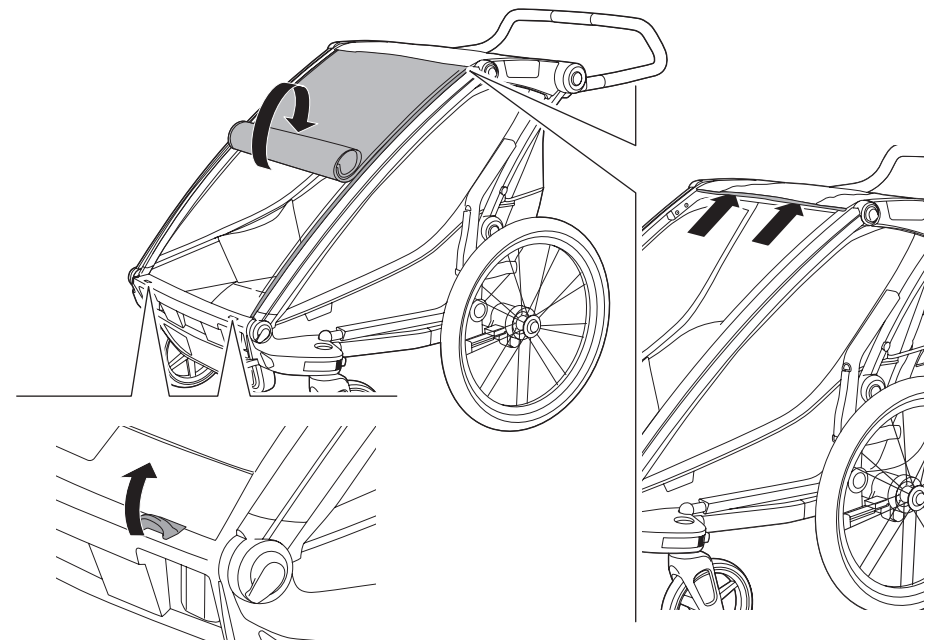
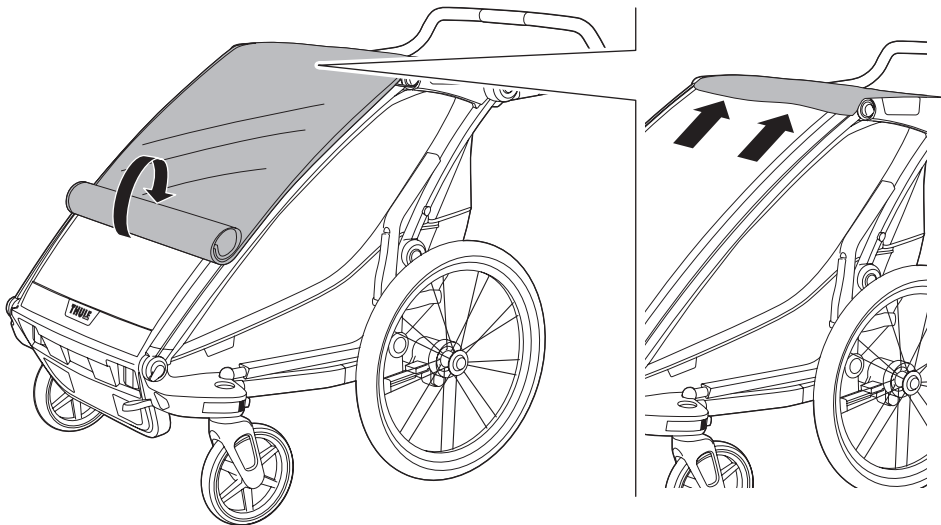
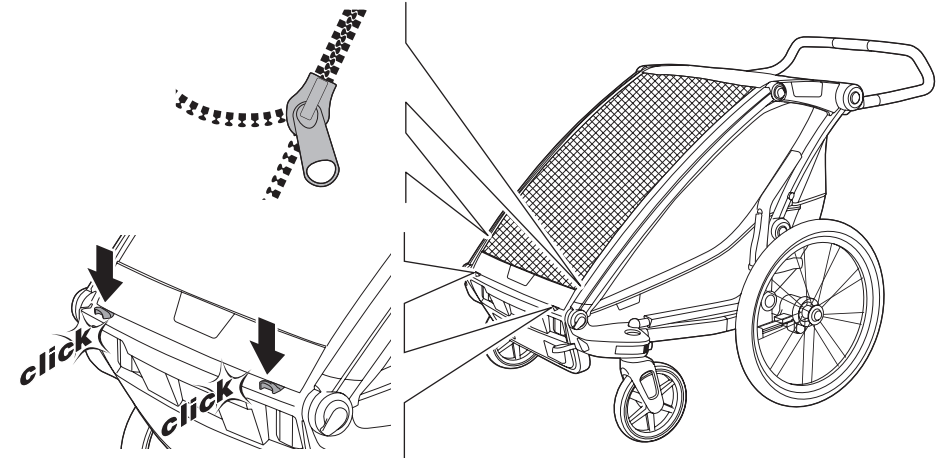
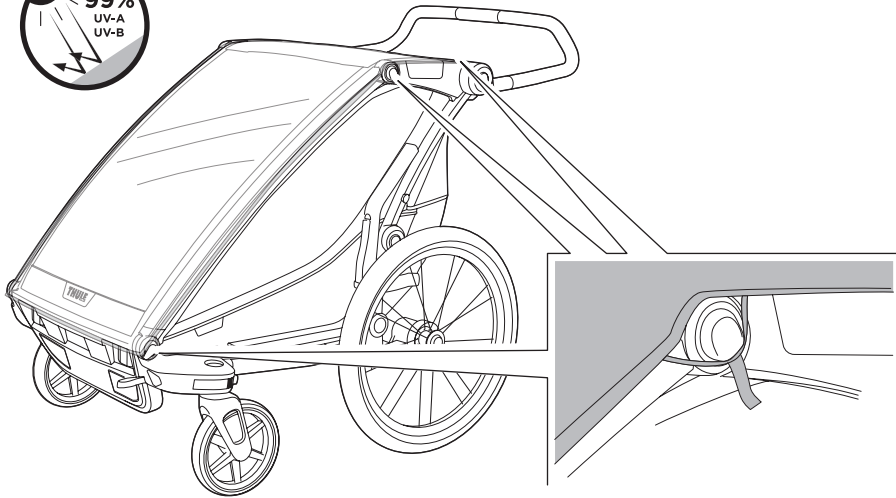
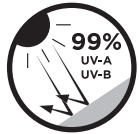
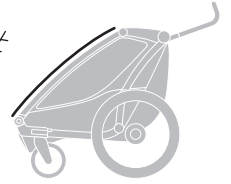
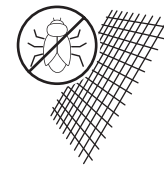
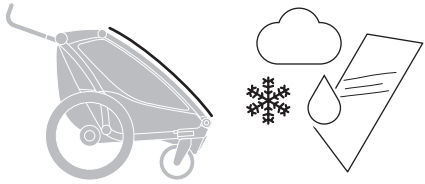

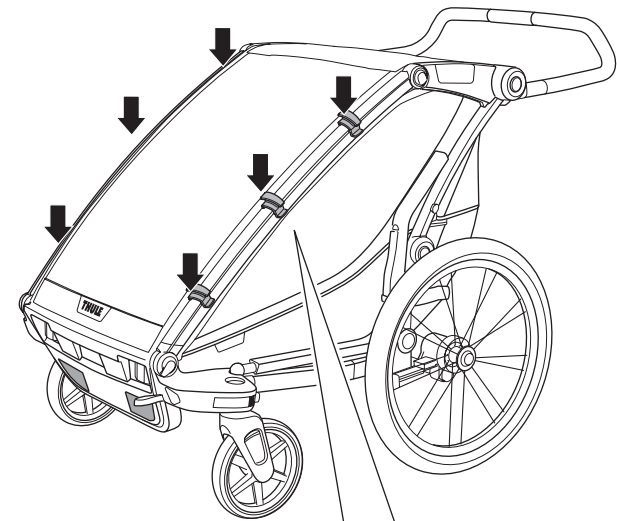
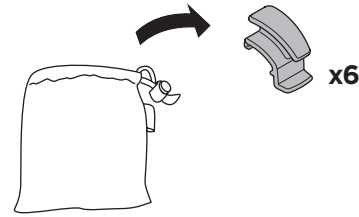
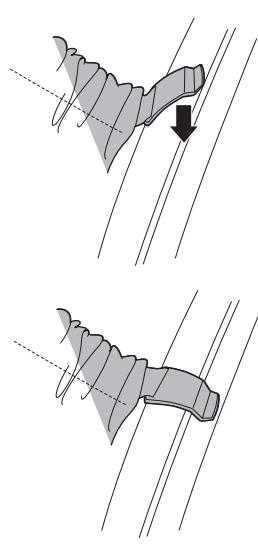
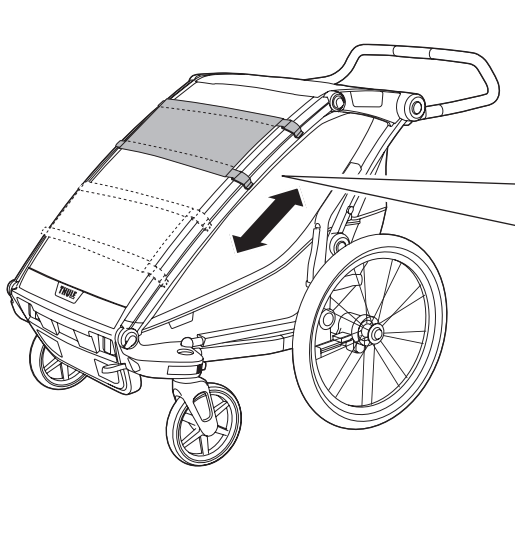
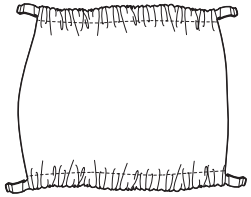
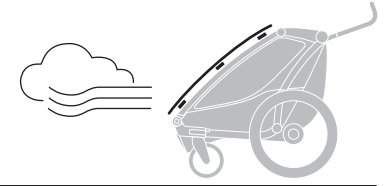
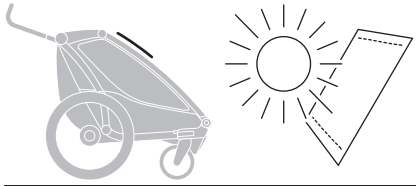

A

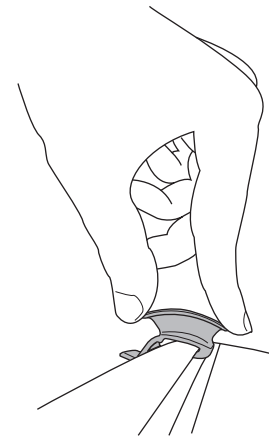

B

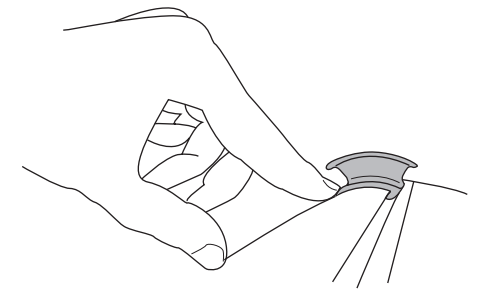

C

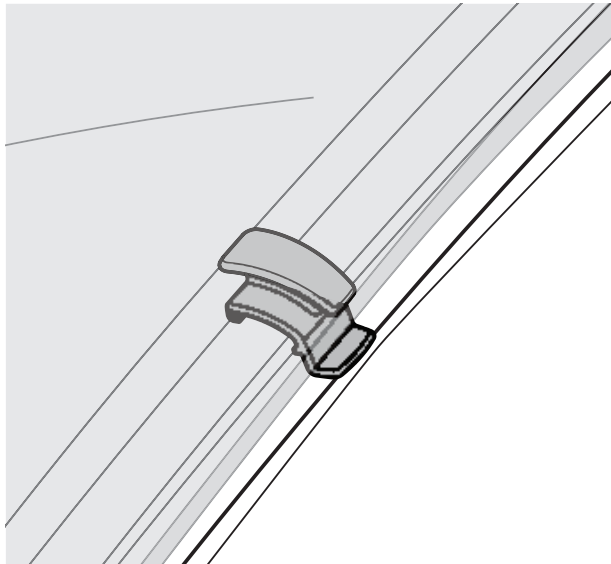
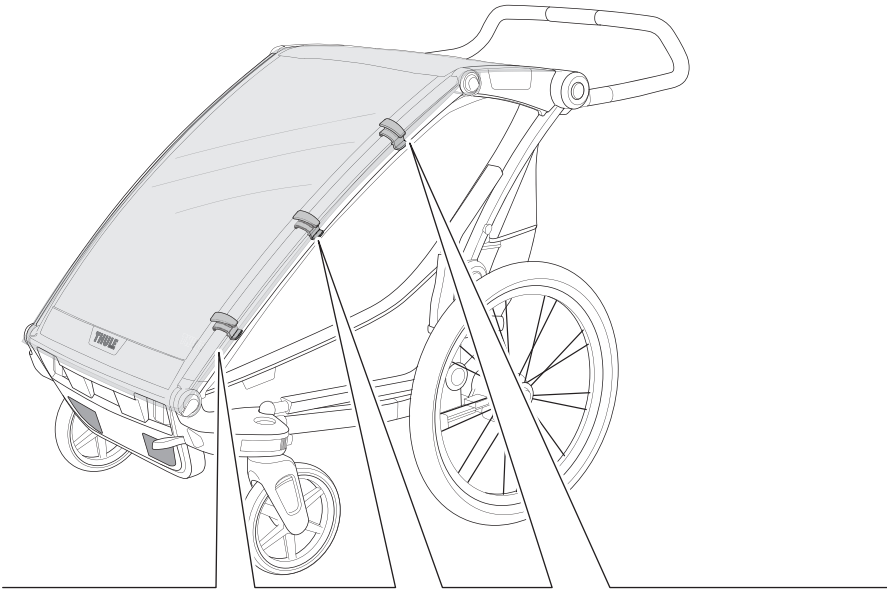

D

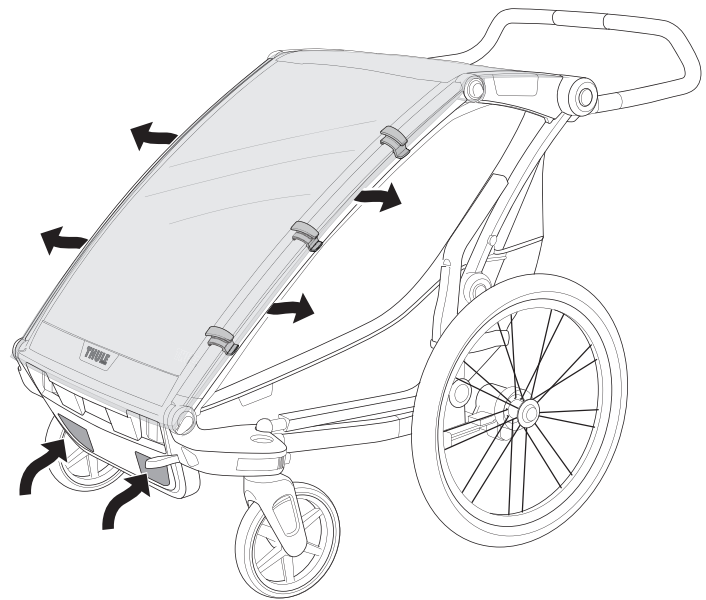
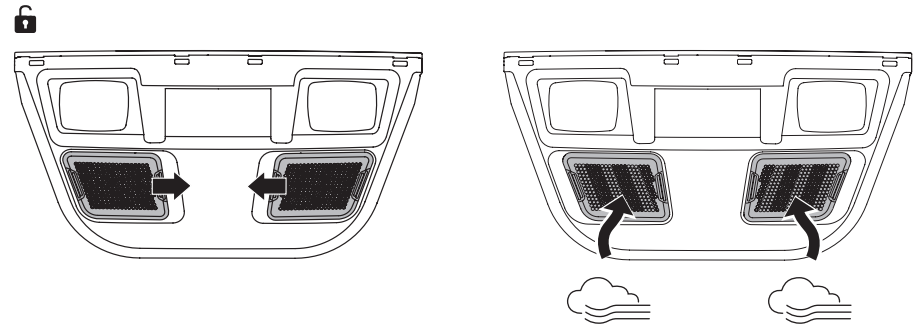
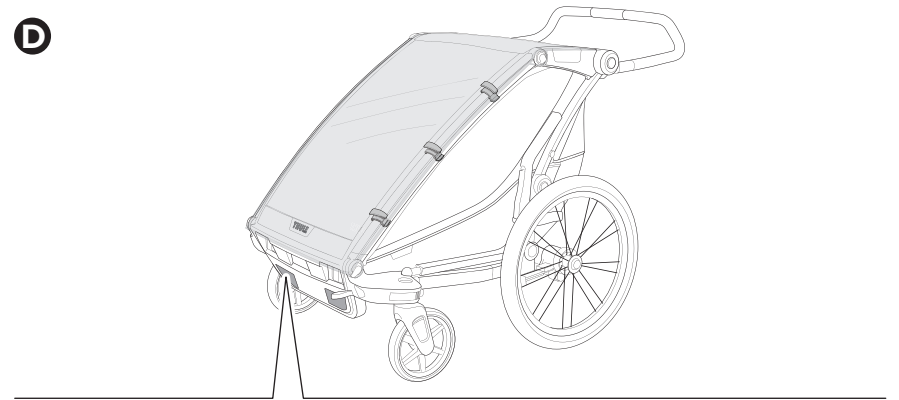

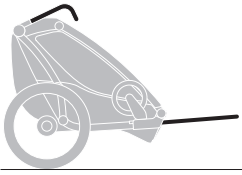

1

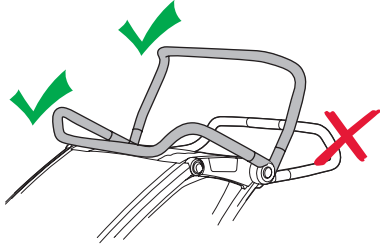

2

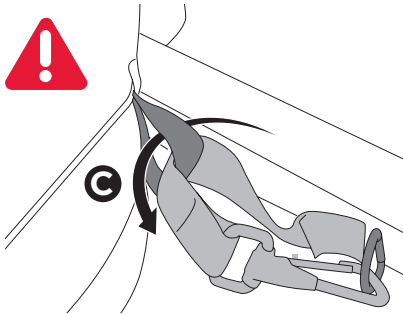
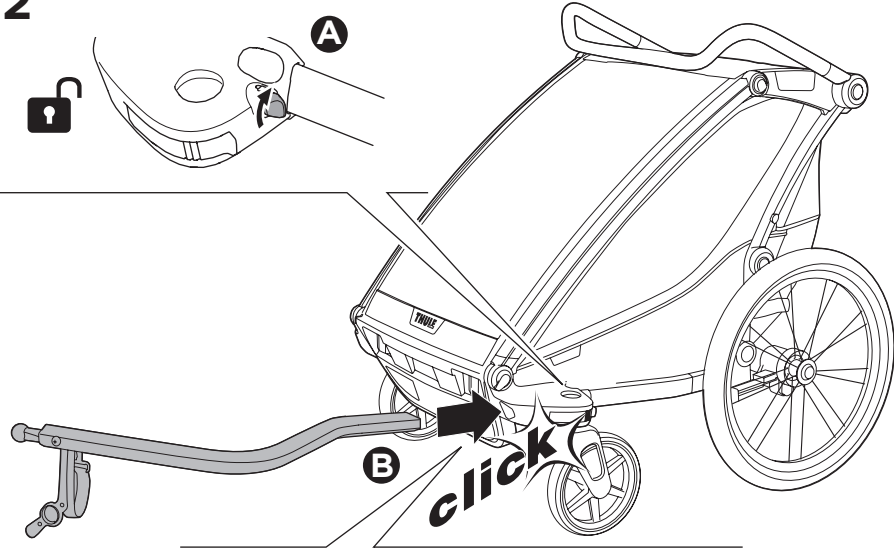

3

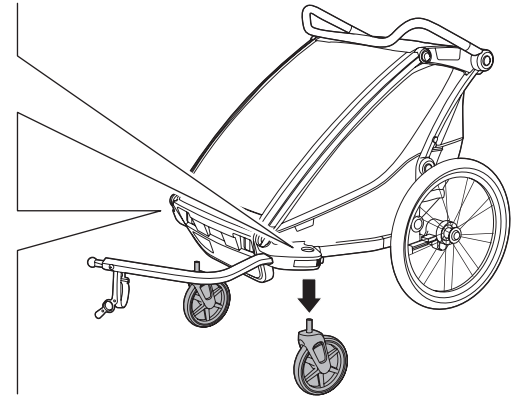
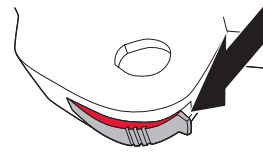

4

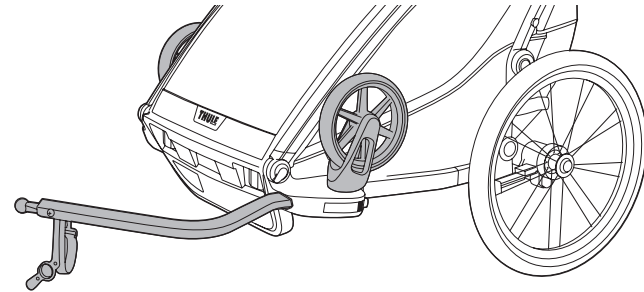
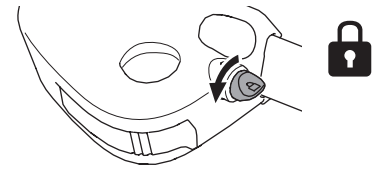
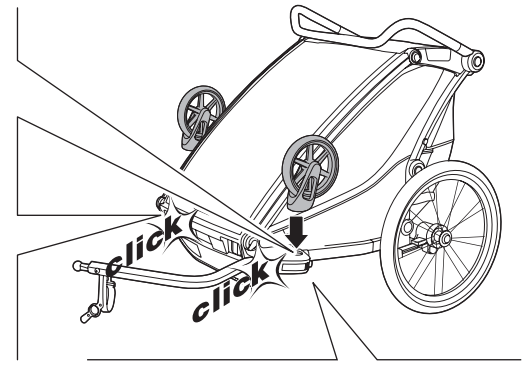
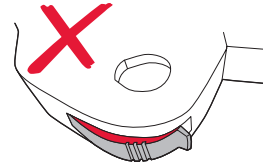
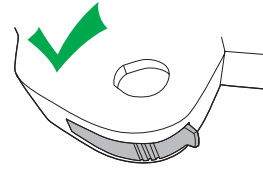

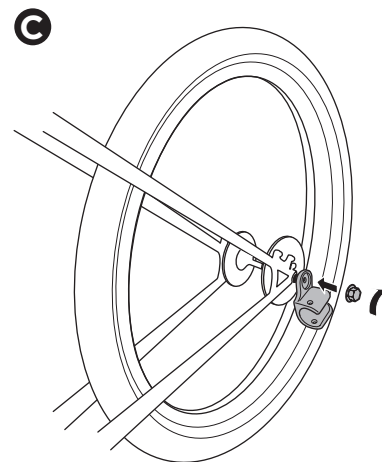
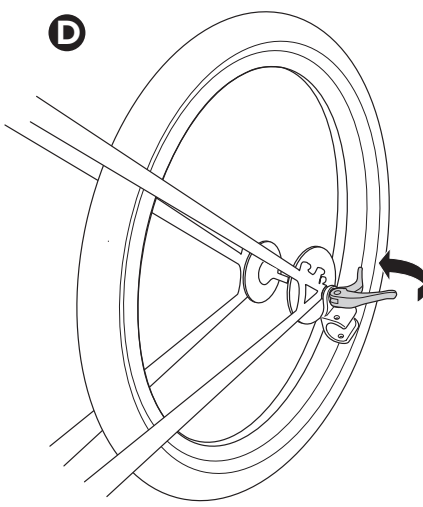
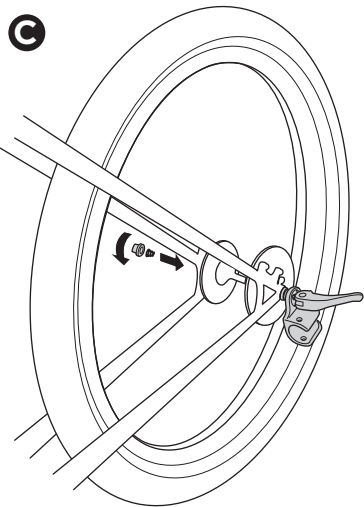
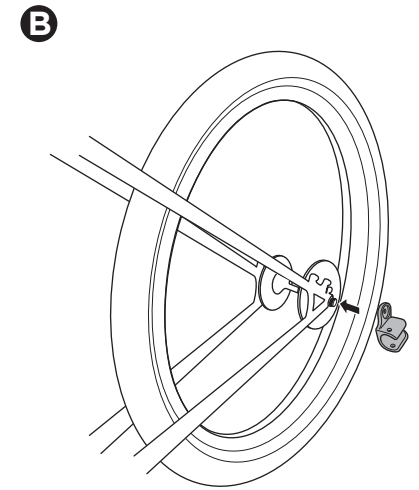
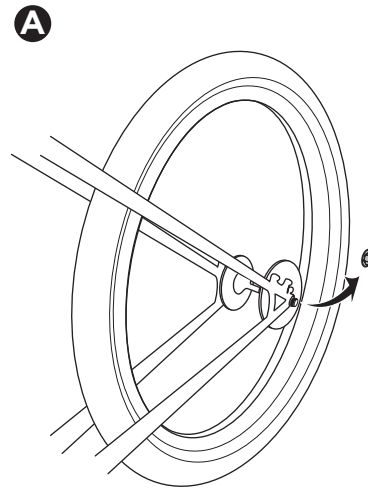
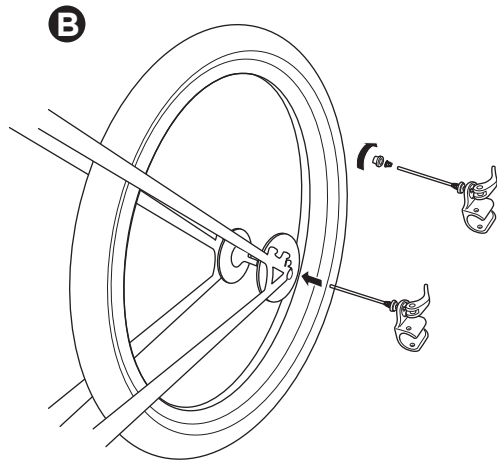
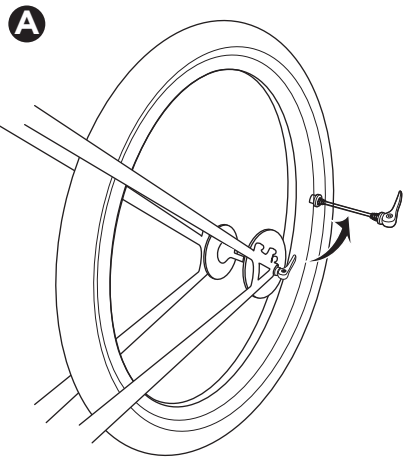
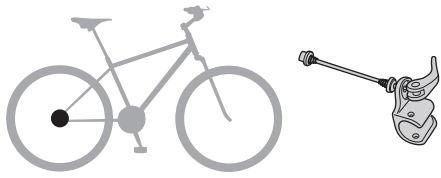

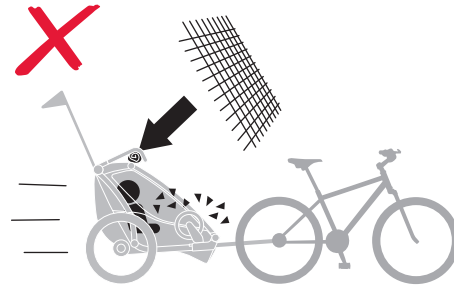
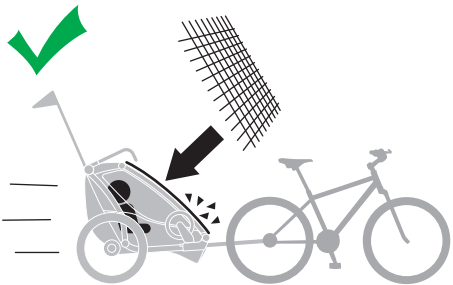
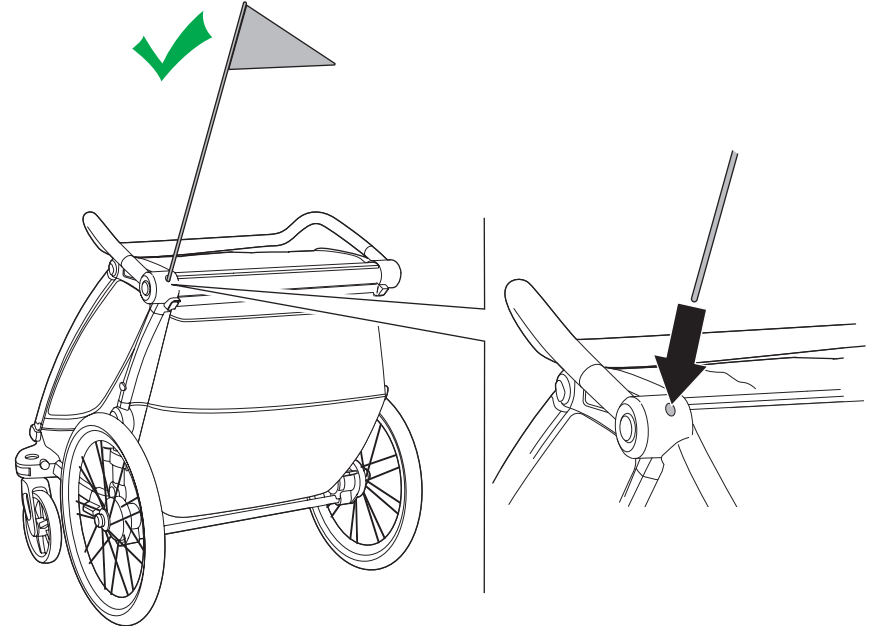
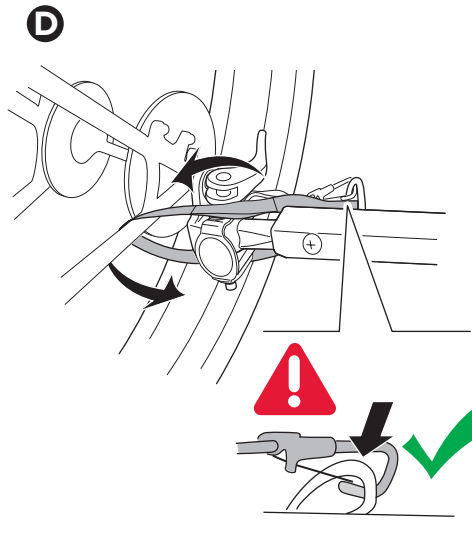
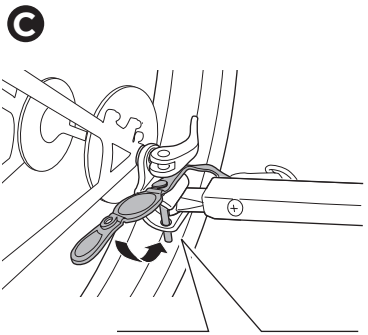
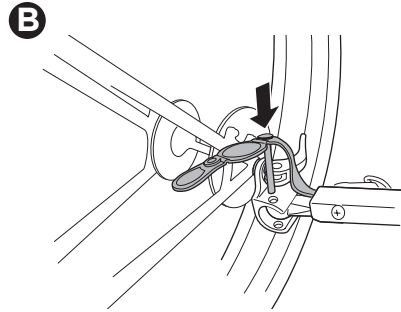
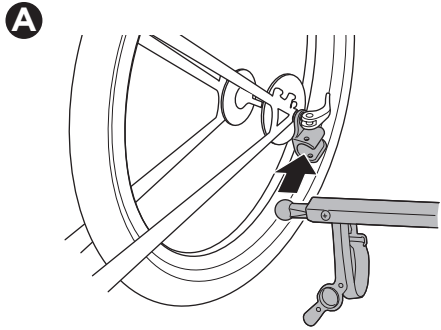
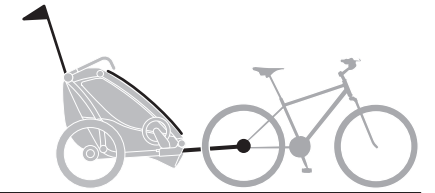
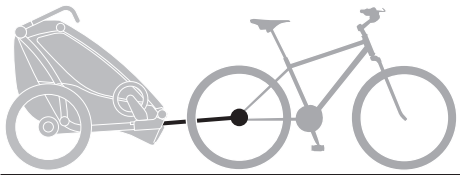

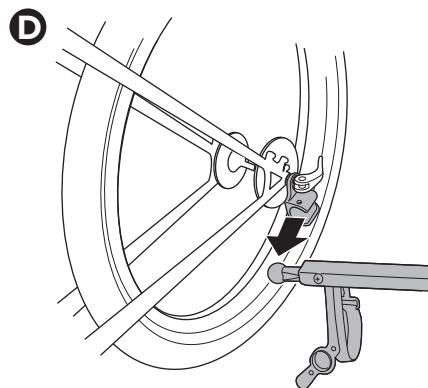
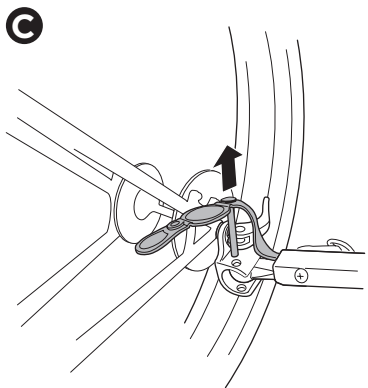
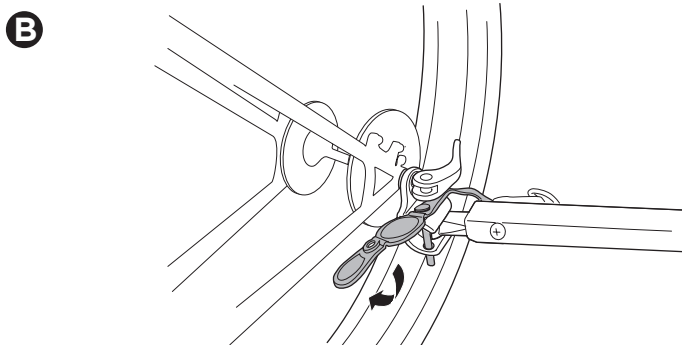
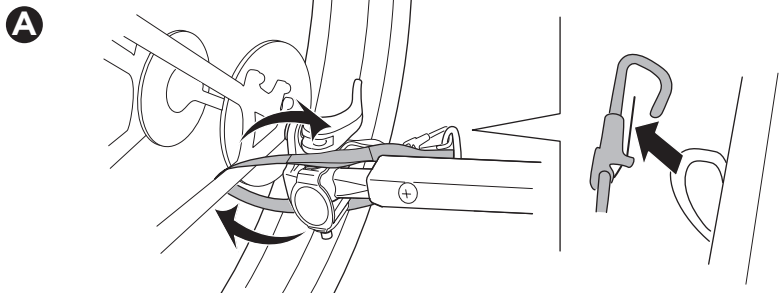
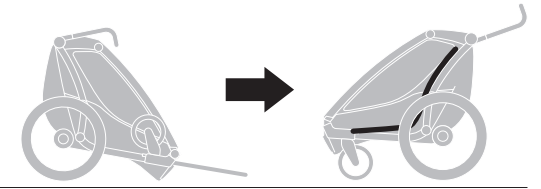
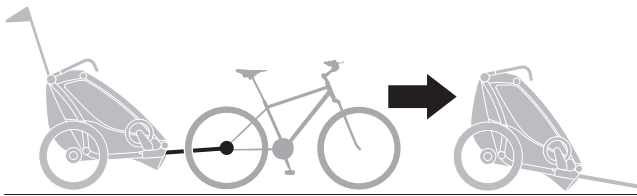

5561469001

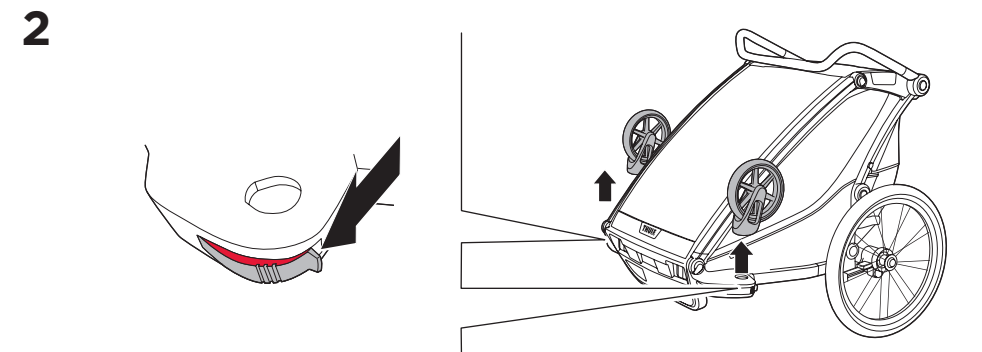
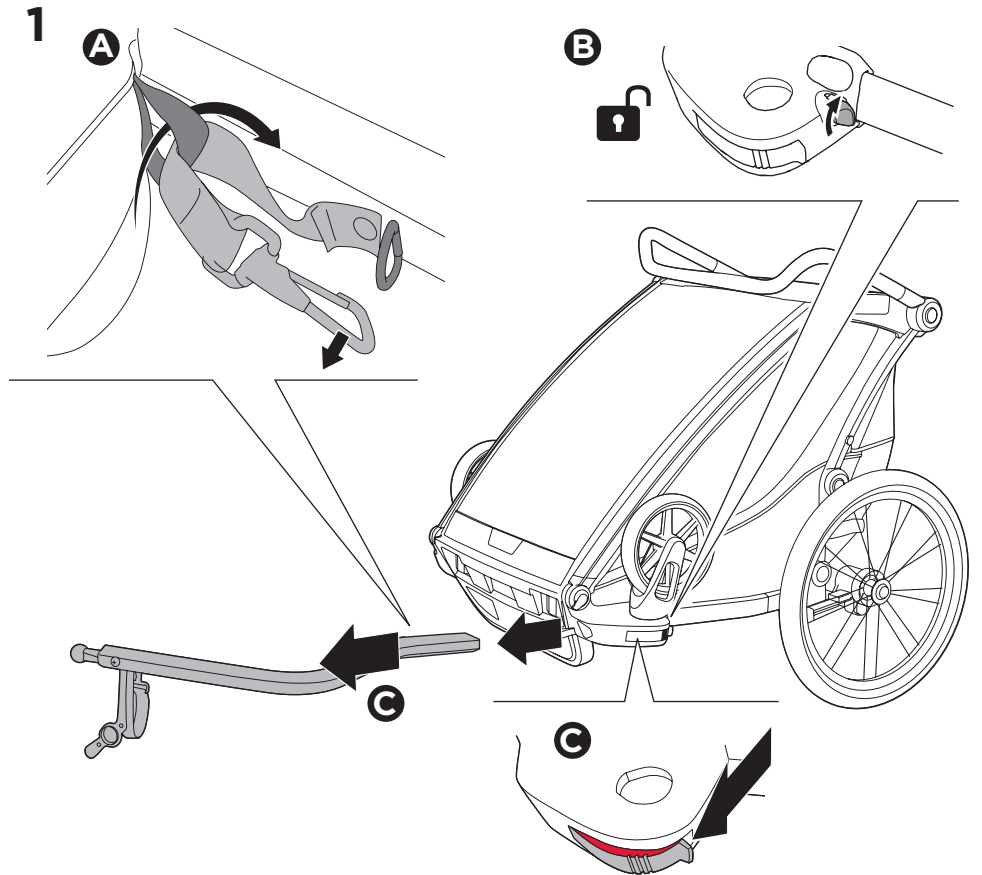

5561469001

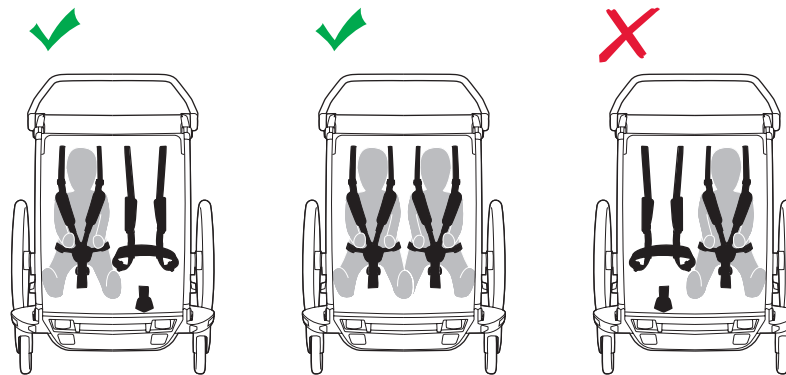
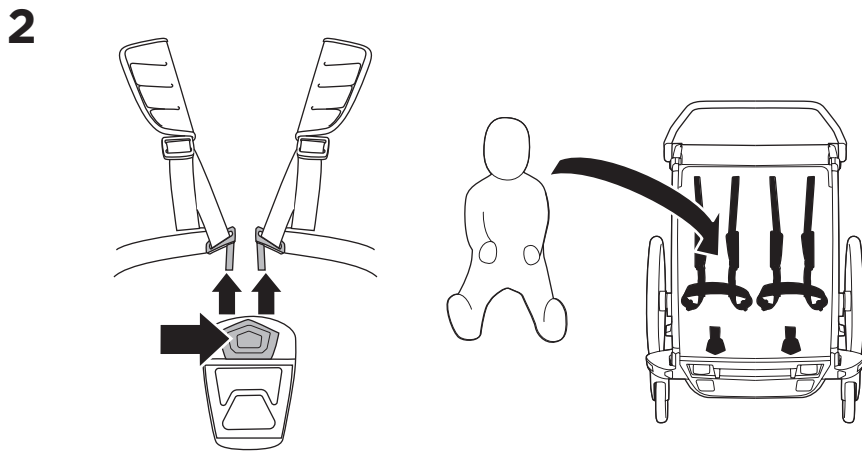
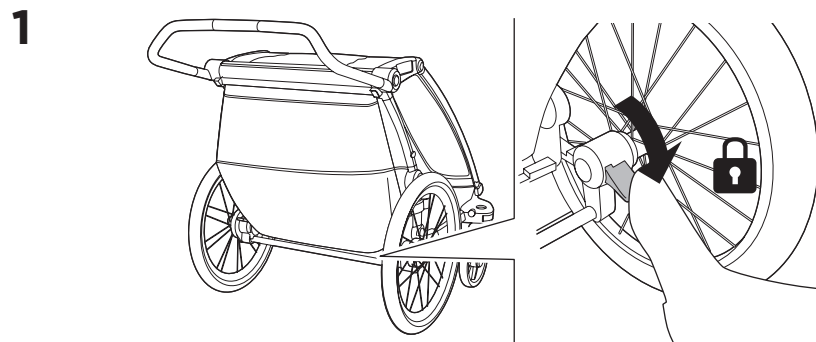
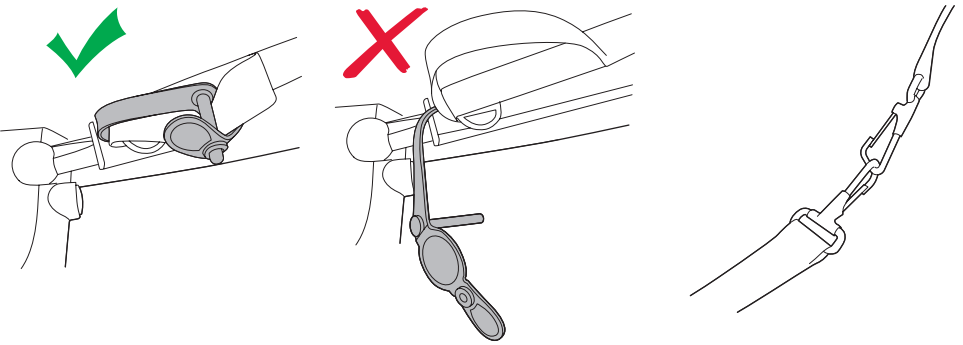
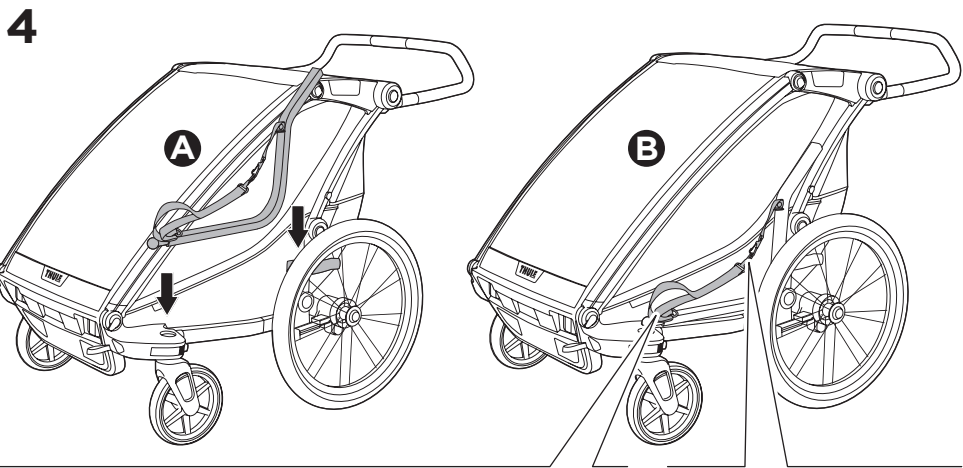
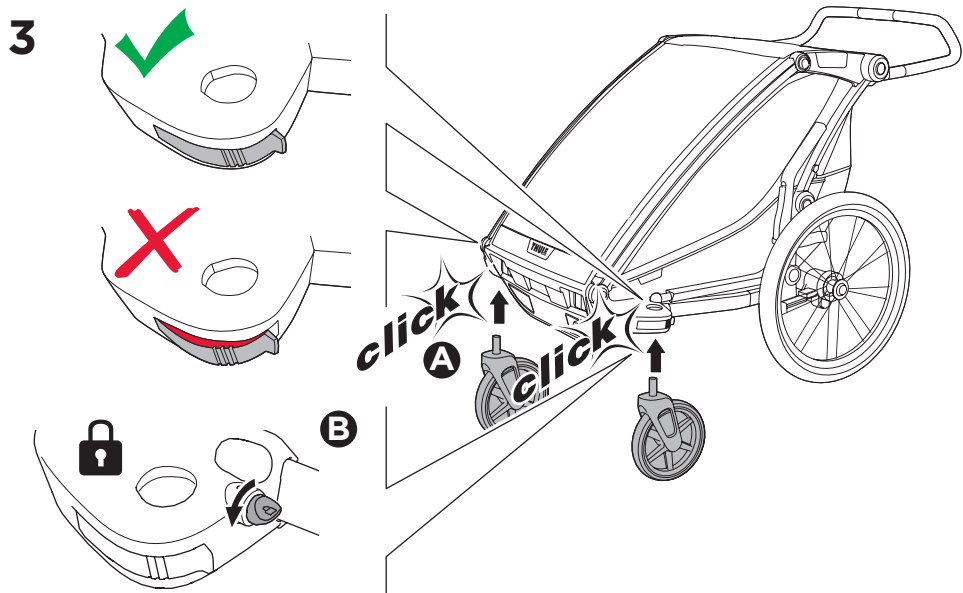

3

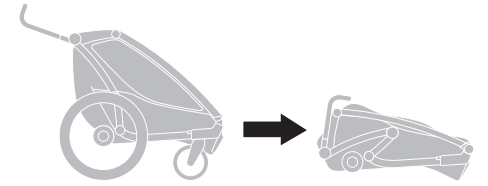
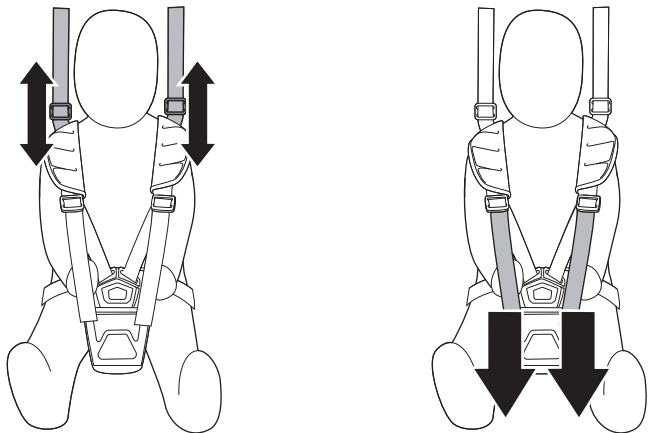
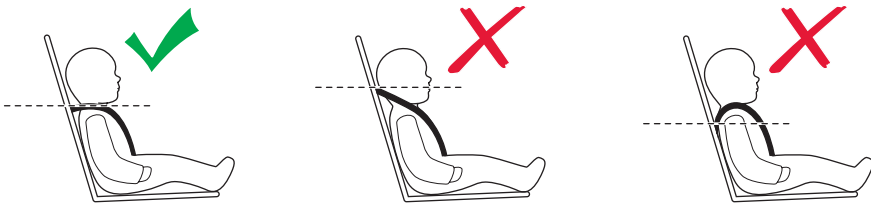
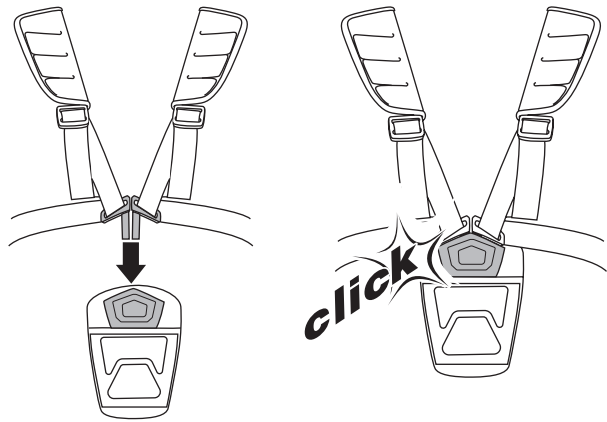

1

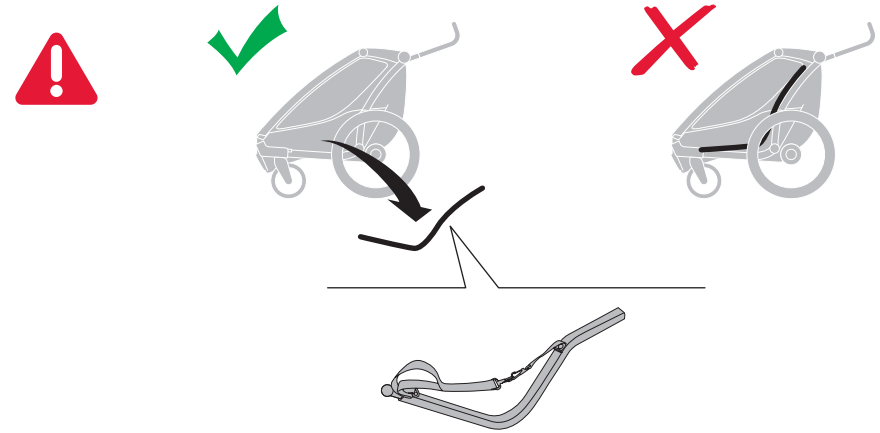

2

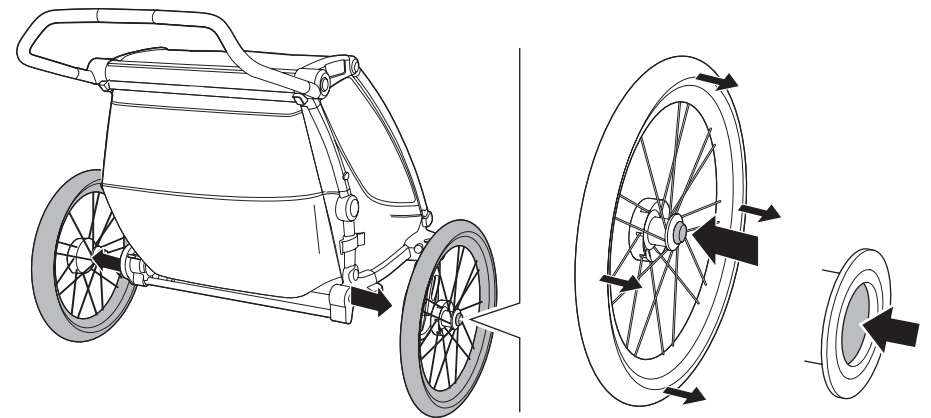

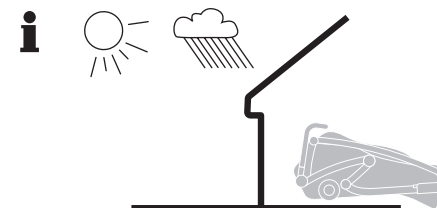
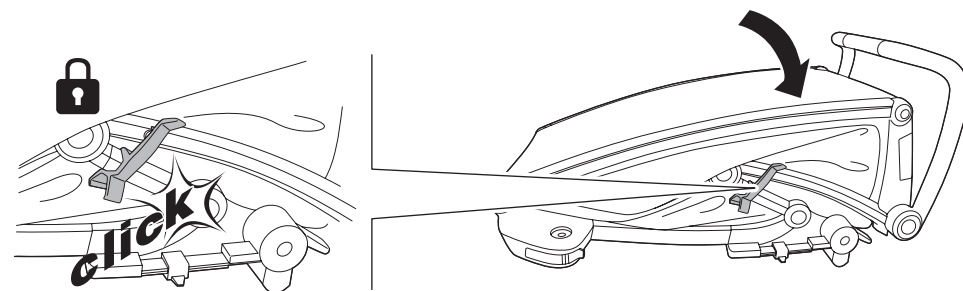
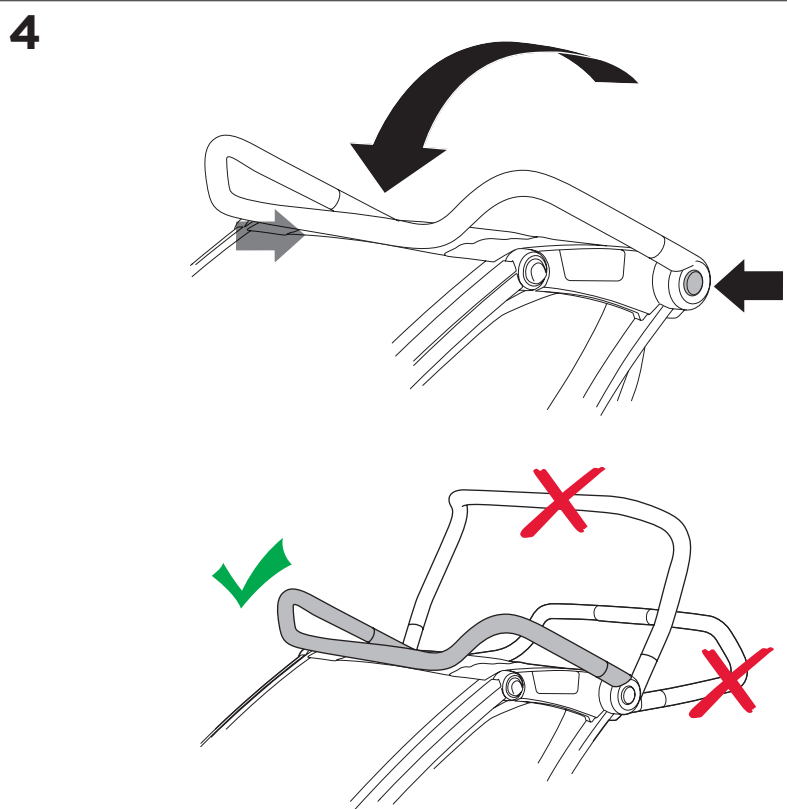
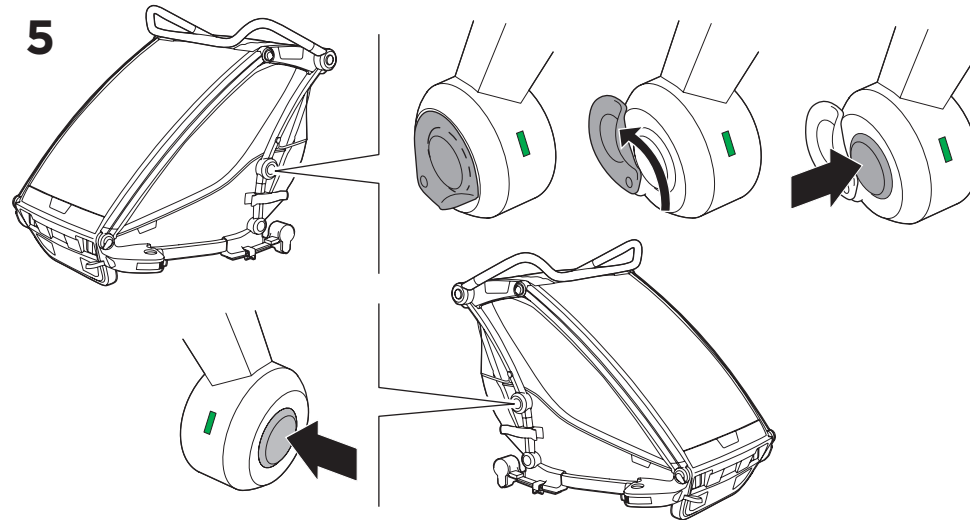
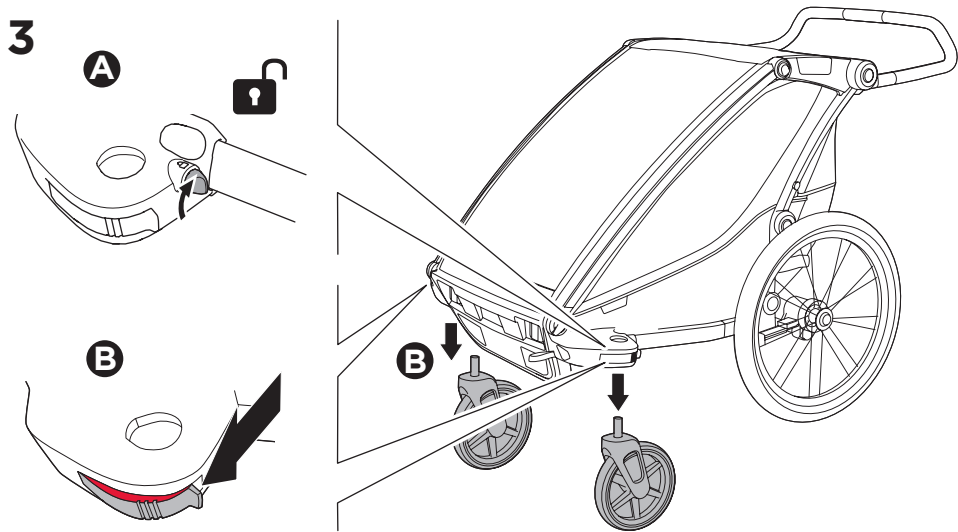

> Product Registration
 Cliquez sur le lien ci-dessous, remplissez le formulaire pour enregistrer votre produit. Vos informations nous aident à améliorer nos produits et services. Pour en savoir plus sur nos produits, visitez www.thule.com.

Enregistrement du produit
 Para registrar seu produto, clique no link abaixo. Preencha o formulário para registrar seu produto. Suas informações nos ajudam a melhorar nossos produtos e serviços. Para saber mais sobre nossos produtos, visite www.thule.com.

Registro del producto
 Para registrar su producto, haga clic en el enlace de registro. Complete el formulario para registrar su producto. Sus datos nos ayudan a mejorar nuestros productos y servicios. Para saber más sobre nuestros productos, visite www.thule.com.

Produktregistrierung
 Klicken Sie auf den unten angegebenen Link für Ihr Produkt. Bitte sei Sie in Eile bei der Datenübermittlung oder einem Rückruf kontaktieren können. Ihre Daten werden für unsere Produkte und Services genutzt. Registrieren Sie Ihr Produkt, bevor Sie die folgende Seite besuchen: www.thule.com/register

THULE



www.thule.com/register

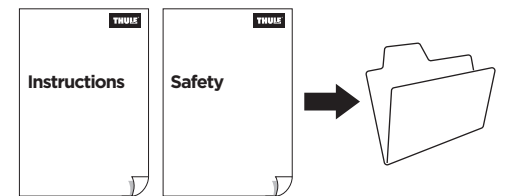



Thule Sweden AB, Borggatan 5
335 73 Hillerstorp, SWEDEN

» PART OF THULE GROUP



info@thule.com

© Thule Group 2022. All rights reserved.



www.thule.com

5561469001