

OAKHAM

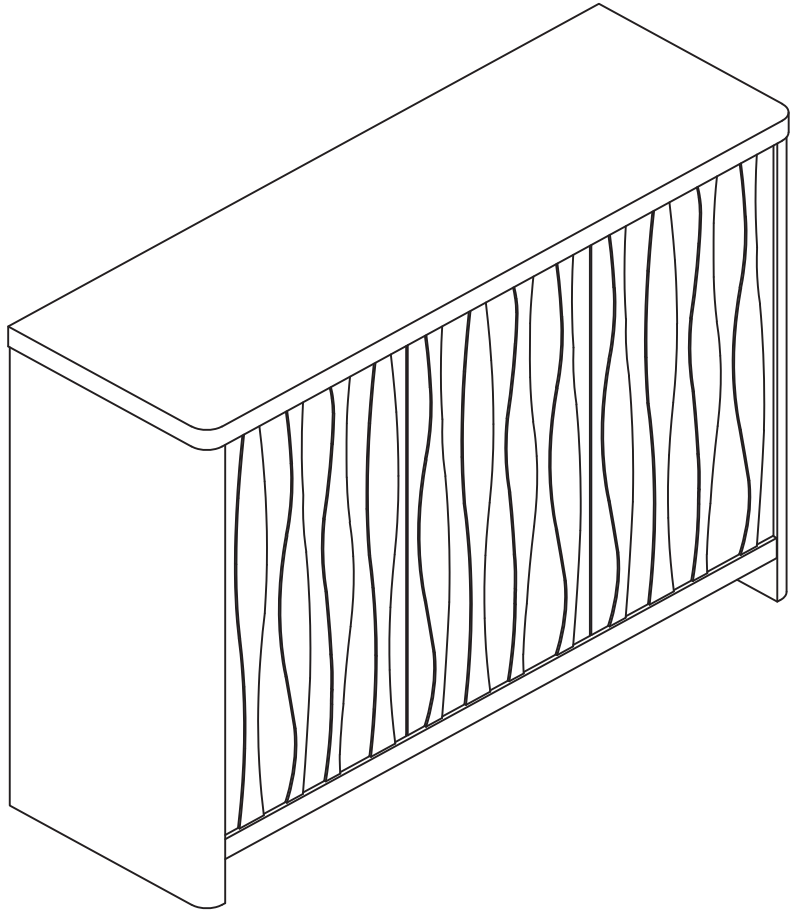

Video instructions can be found at:
<https://oakhamdesign.com/pages/assembly-videos>

Your satisfaction is our priority!

If for any reason there is anything missing, incorrect, or different from your expectation, please contact us first at







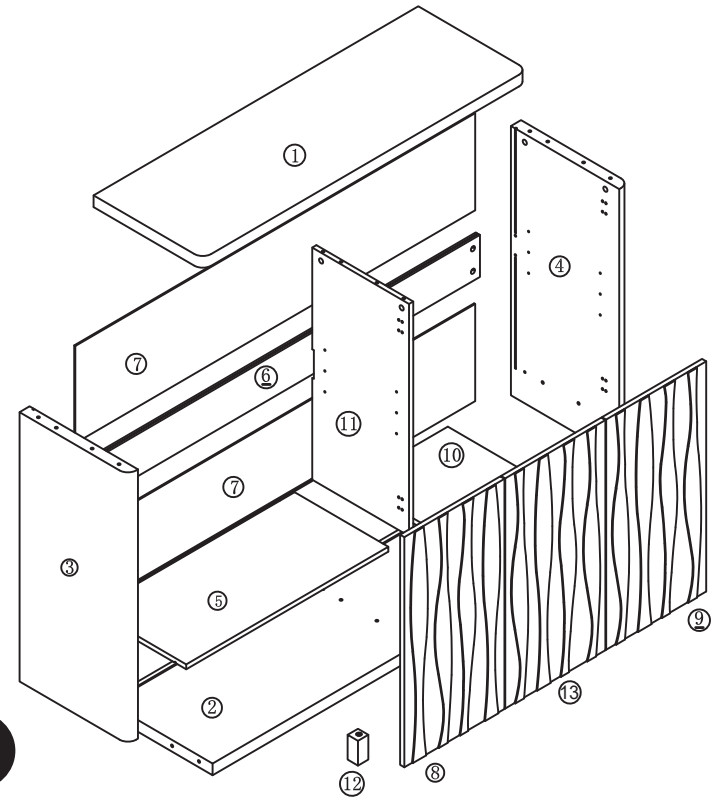





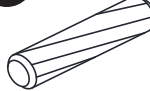

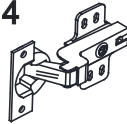

care@oakhamdesign.com

We will resolve your issue within 24 hours, guaranteed!

Parts list



Hardware list

A x14 	B x14 	C x12 $\phi 8 \times 30 \text{mm}$ 	D x8 	E x8 $\phi 3 \times 16 \text{mm}$ 
F x36 $\phi 4 \times 14 \text{mm}$ 	G x8 	H x14 $\phi 20$ 	I x3 	J x4 
K x3 M3x13mm 	L x12 $\phi 4 \times 15 \text{mm}$ 	M x2 		
N x5 	O x1 	P x2 	Q x2 $\phi 4, 2 \times 50 \text{mm}$ 	

Step 1

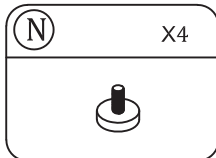
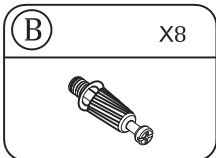
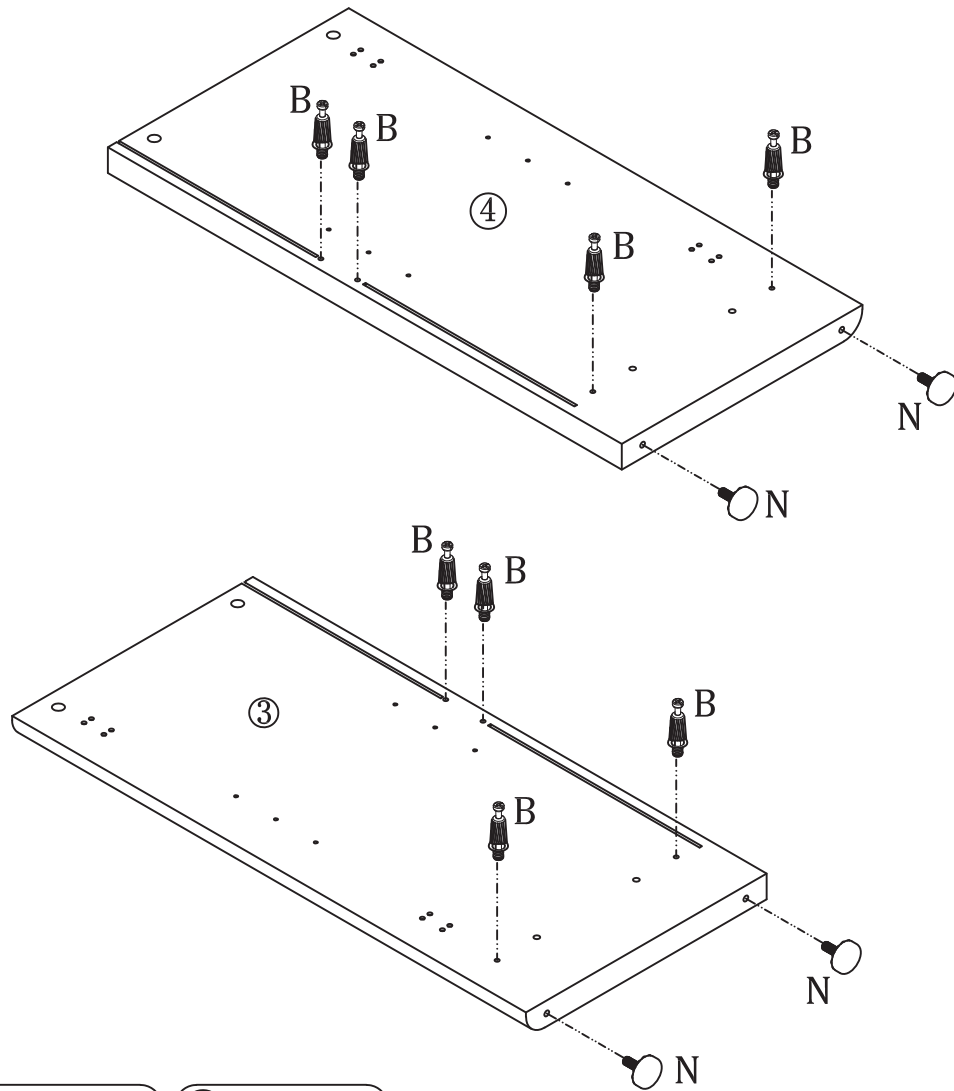

Step 2

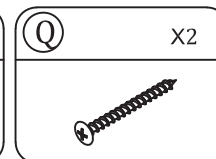
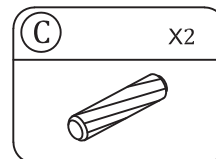
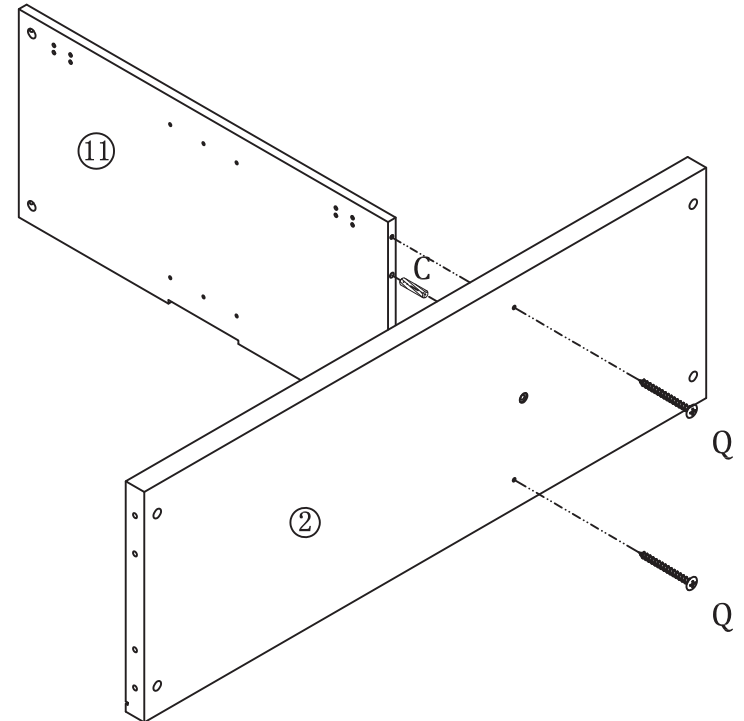

Step 3

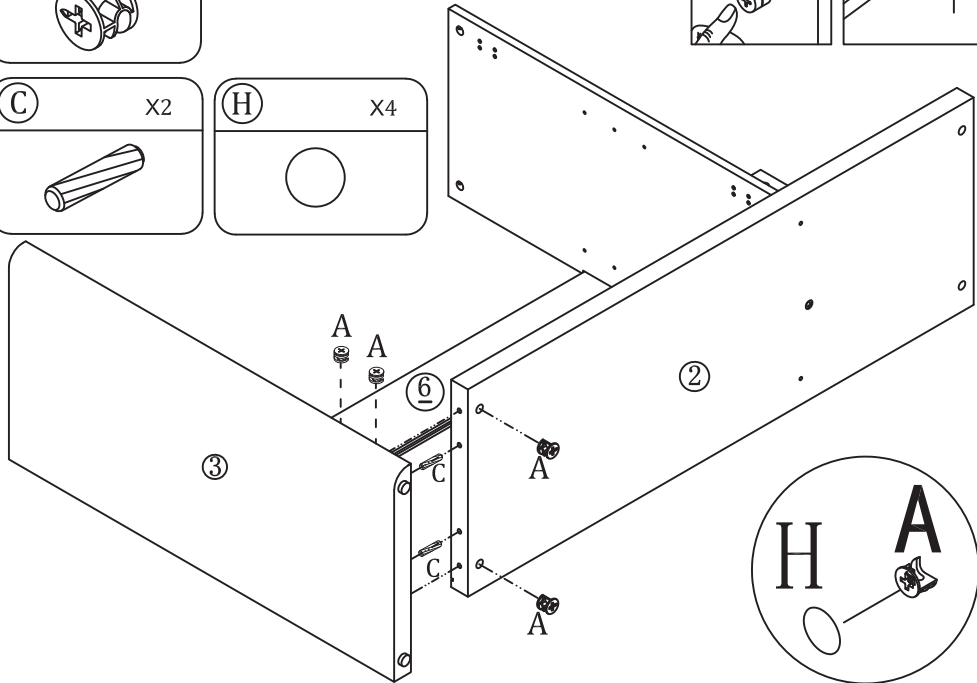
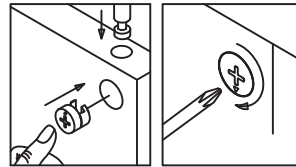
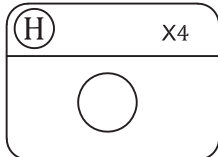
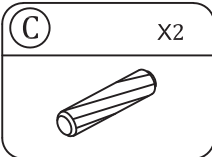
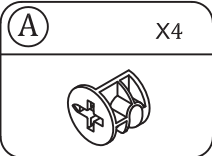
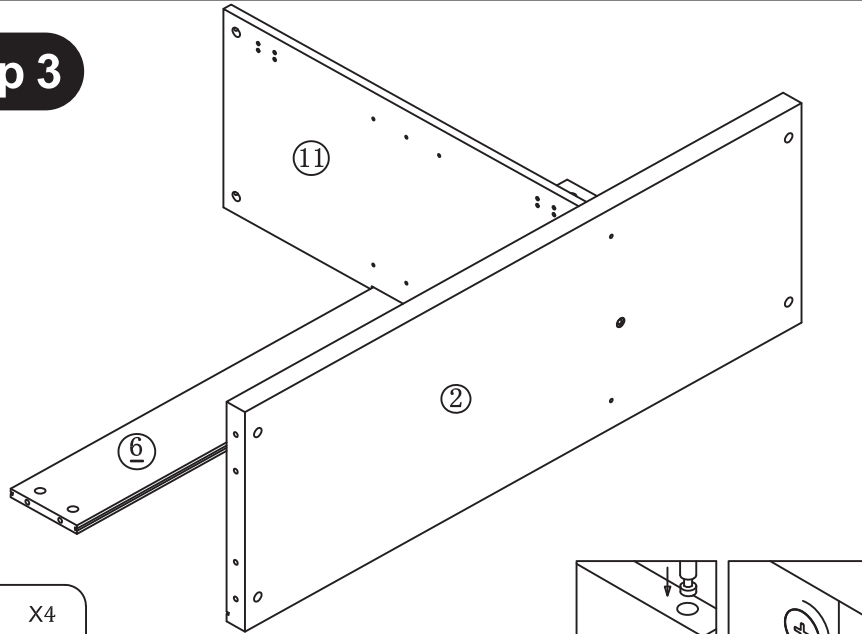

Step 4

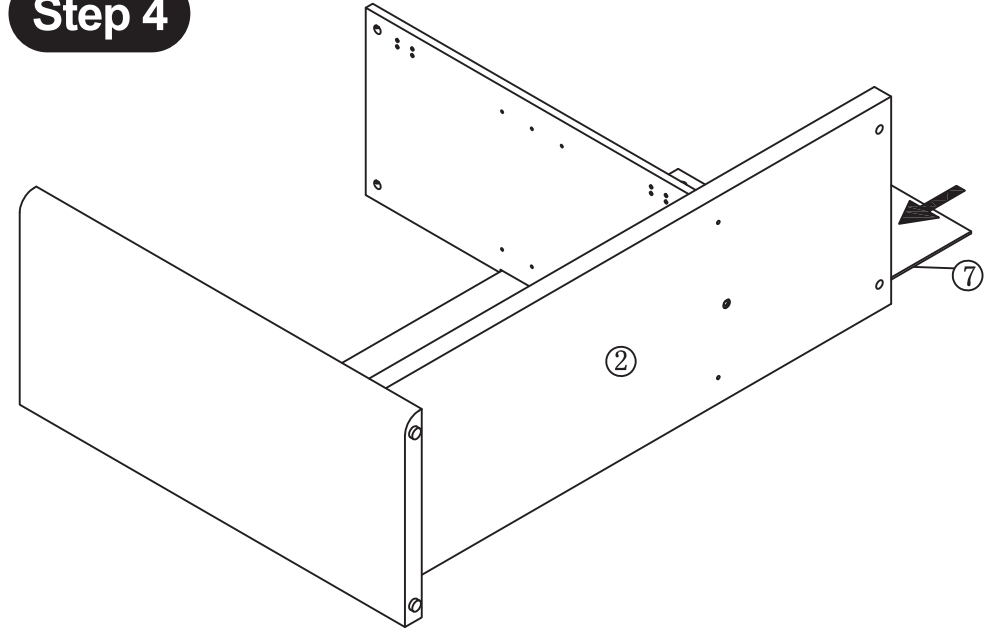

Note: Component 12 has different sized holes on the top and bottom sides. The larger hole fits accessory N, and the smaller hole fits accessory O.

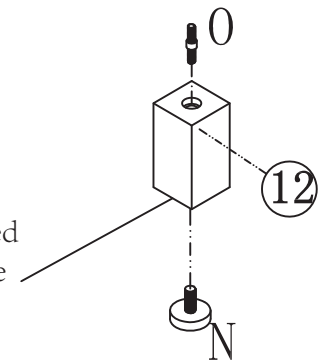
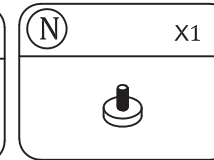
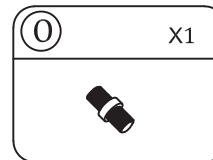

Step 5

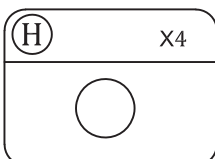
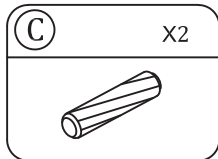
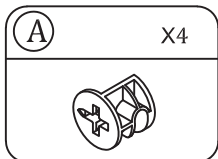
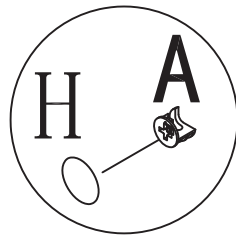
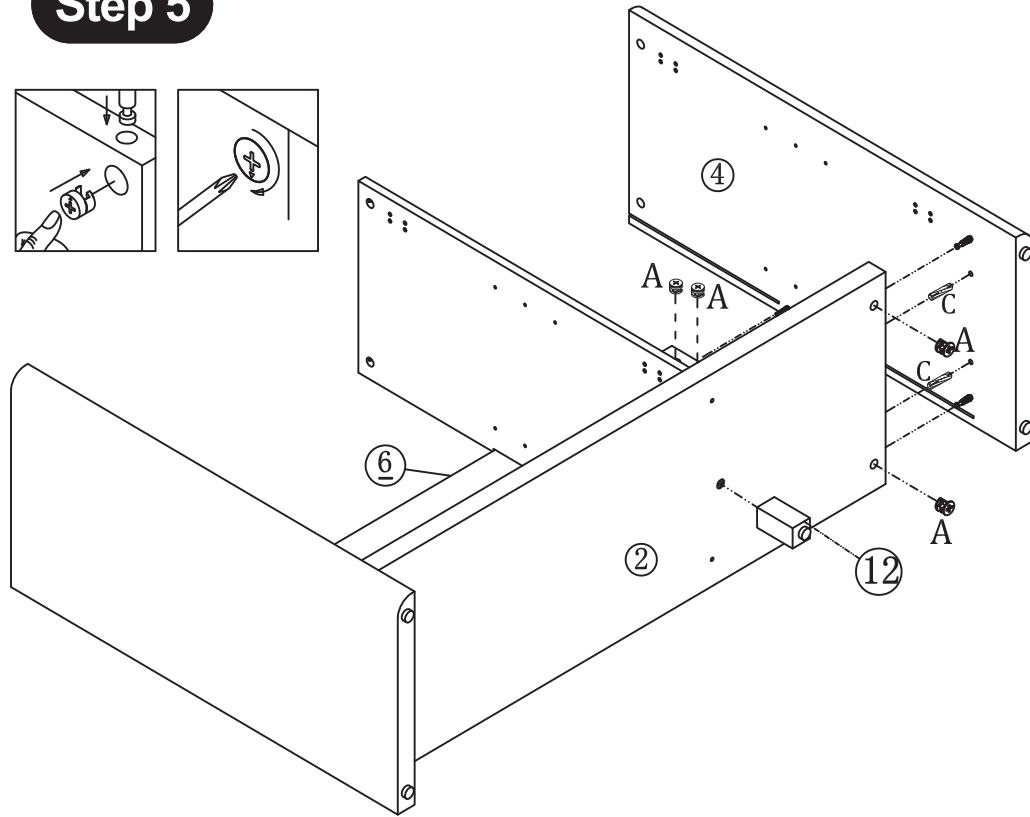
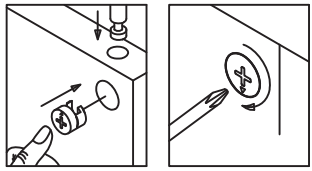

Step 6

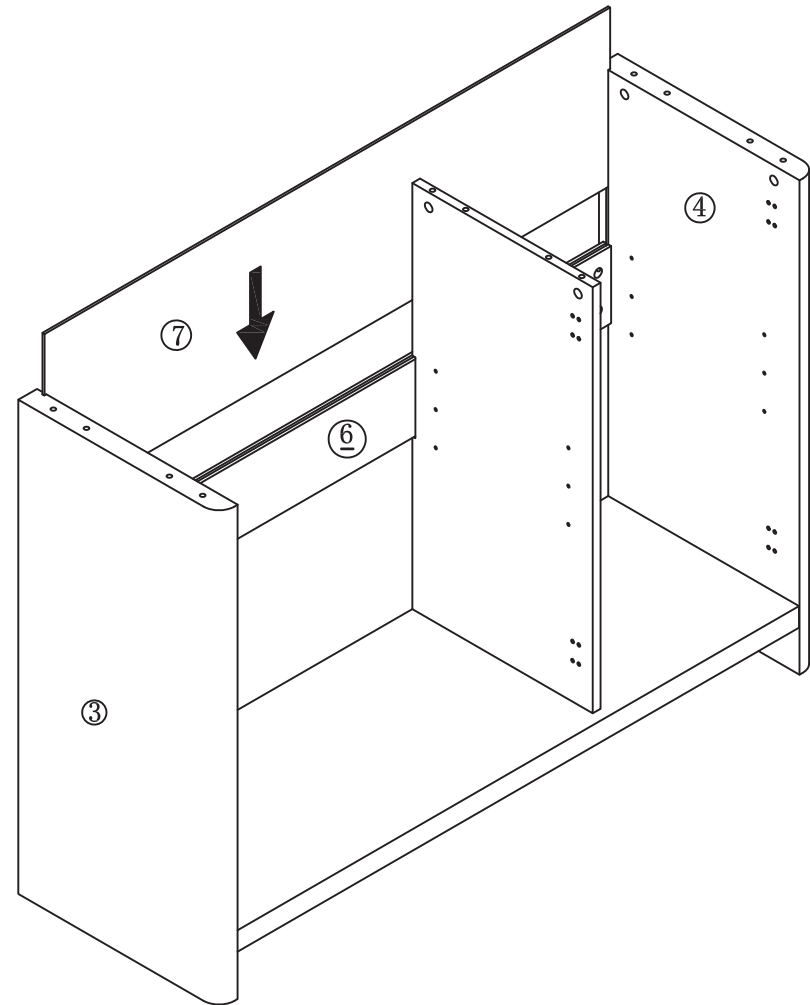

Step 7

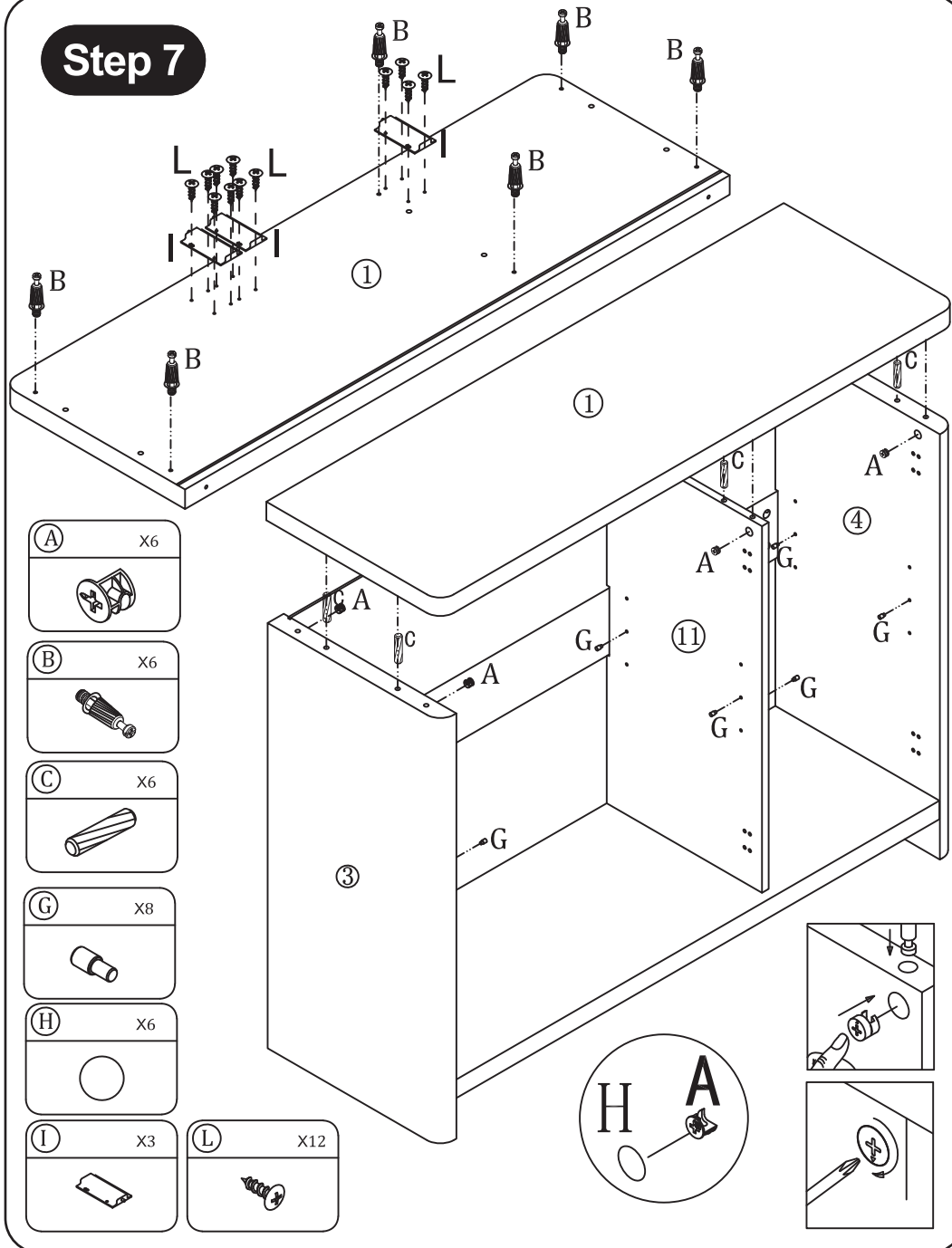

Step 8

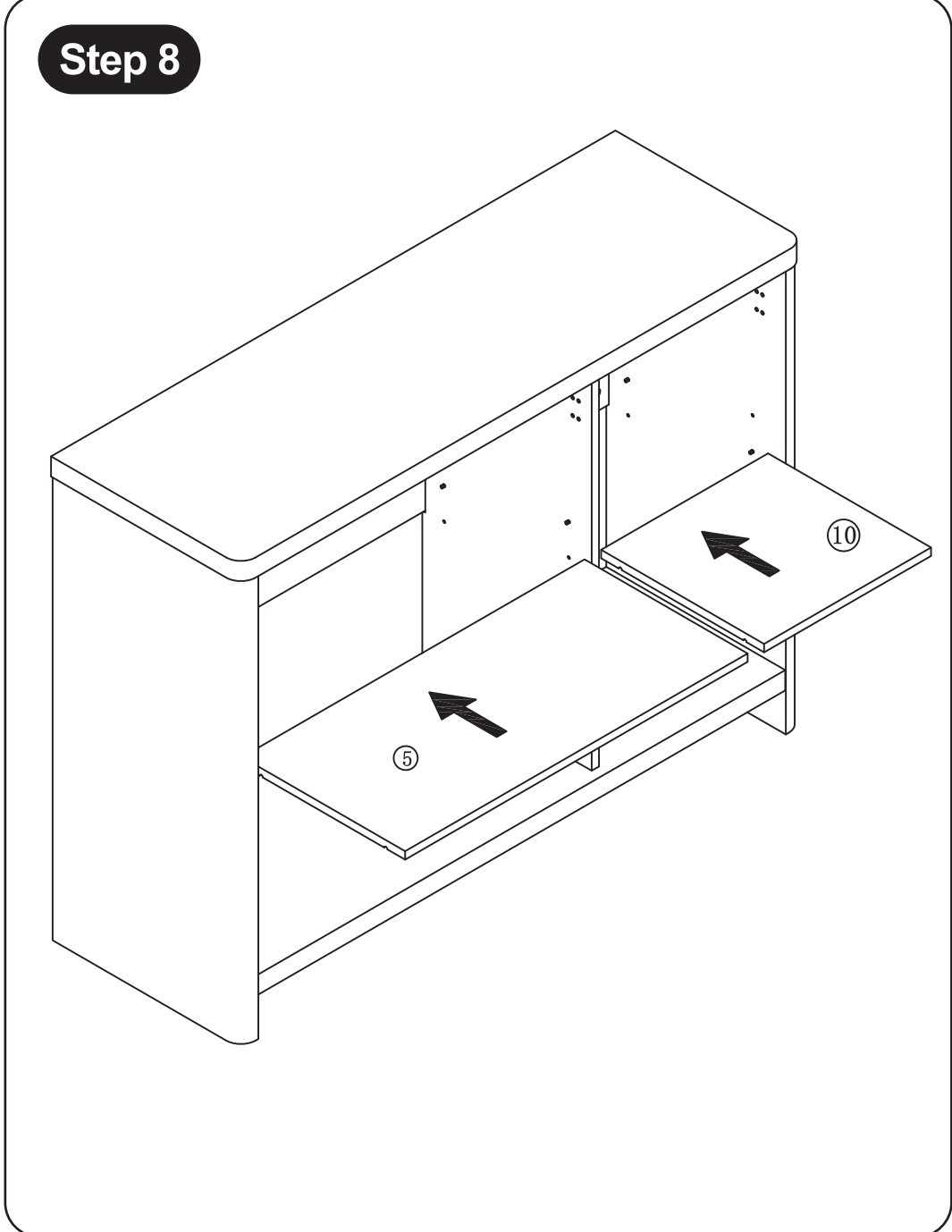

Step 9

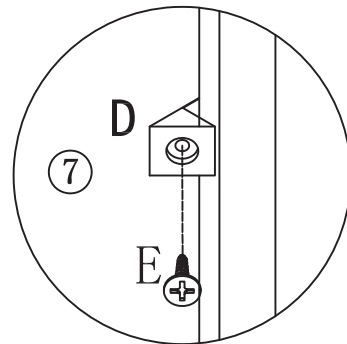
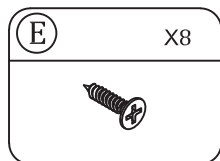
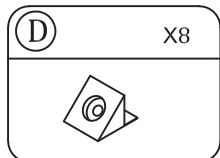
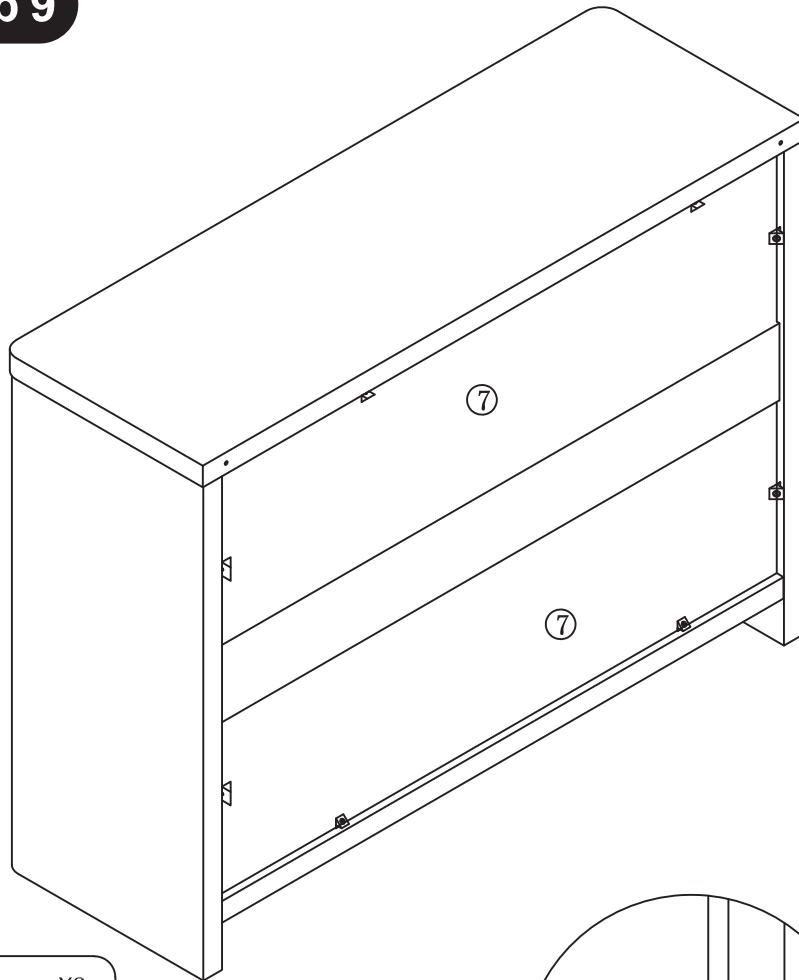

Step 10

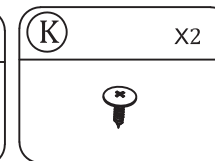
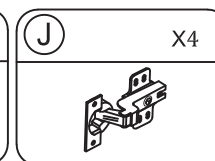
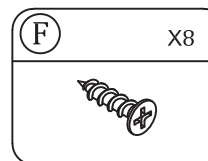
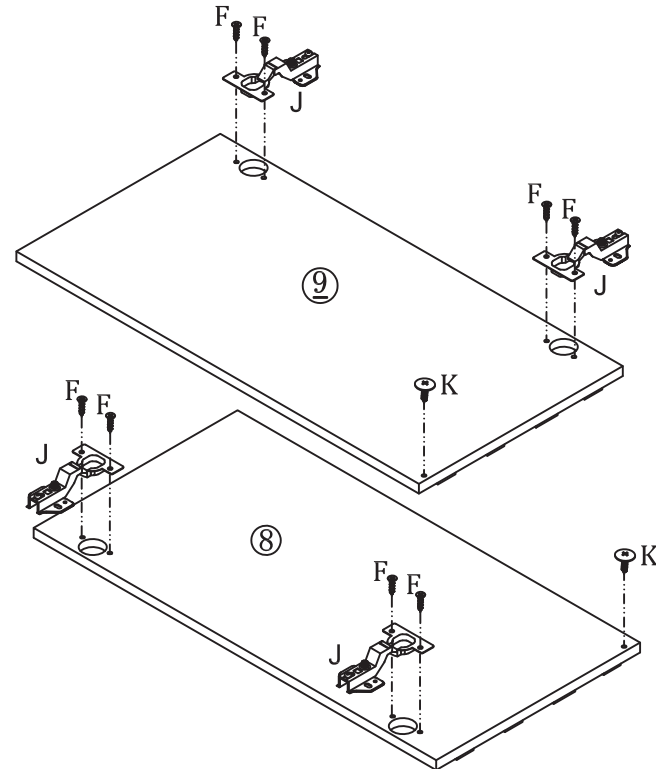
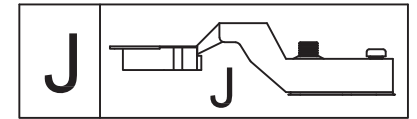

Step 11

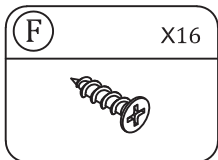
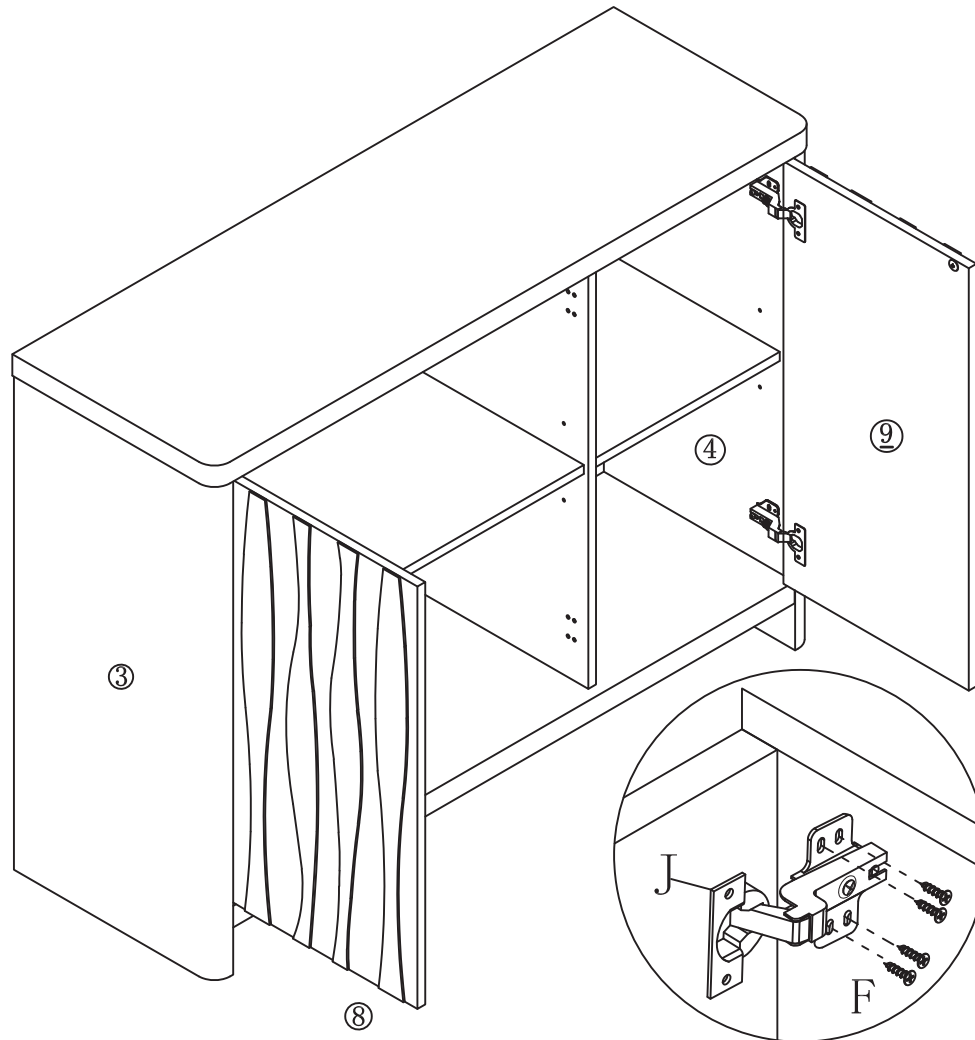

Step 12

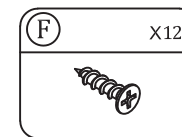
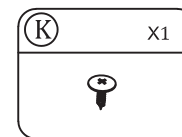
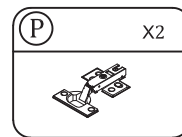
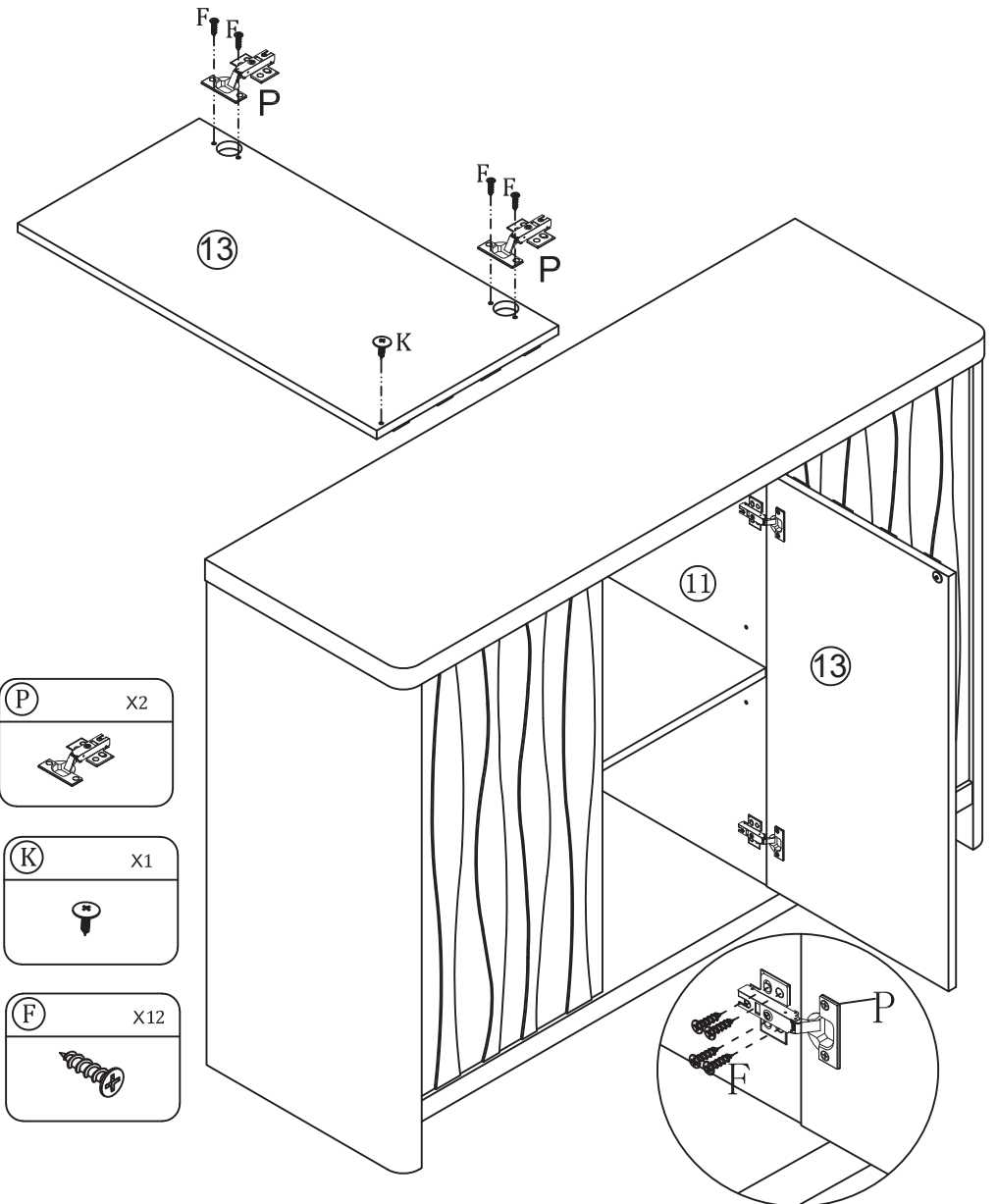
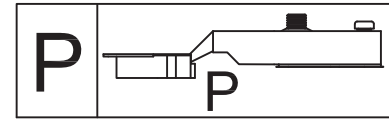

Step 13

WARNING

Serious or fatal injuries can occur from furniture tipping over. To prevent the furniture from tipping over we recommend that it is permanently fixed to the wall. Wall anchor and hardware are included with this product. Please make sure hardware is suitable for your walls before installing, as different wall materials may require different types of anchors.

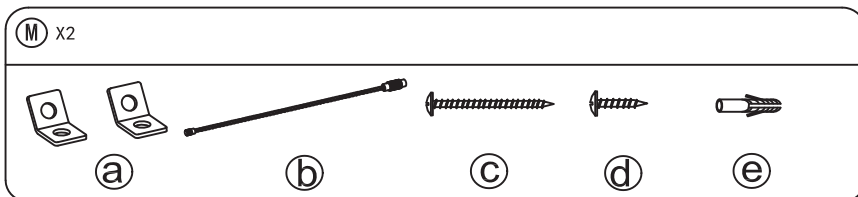
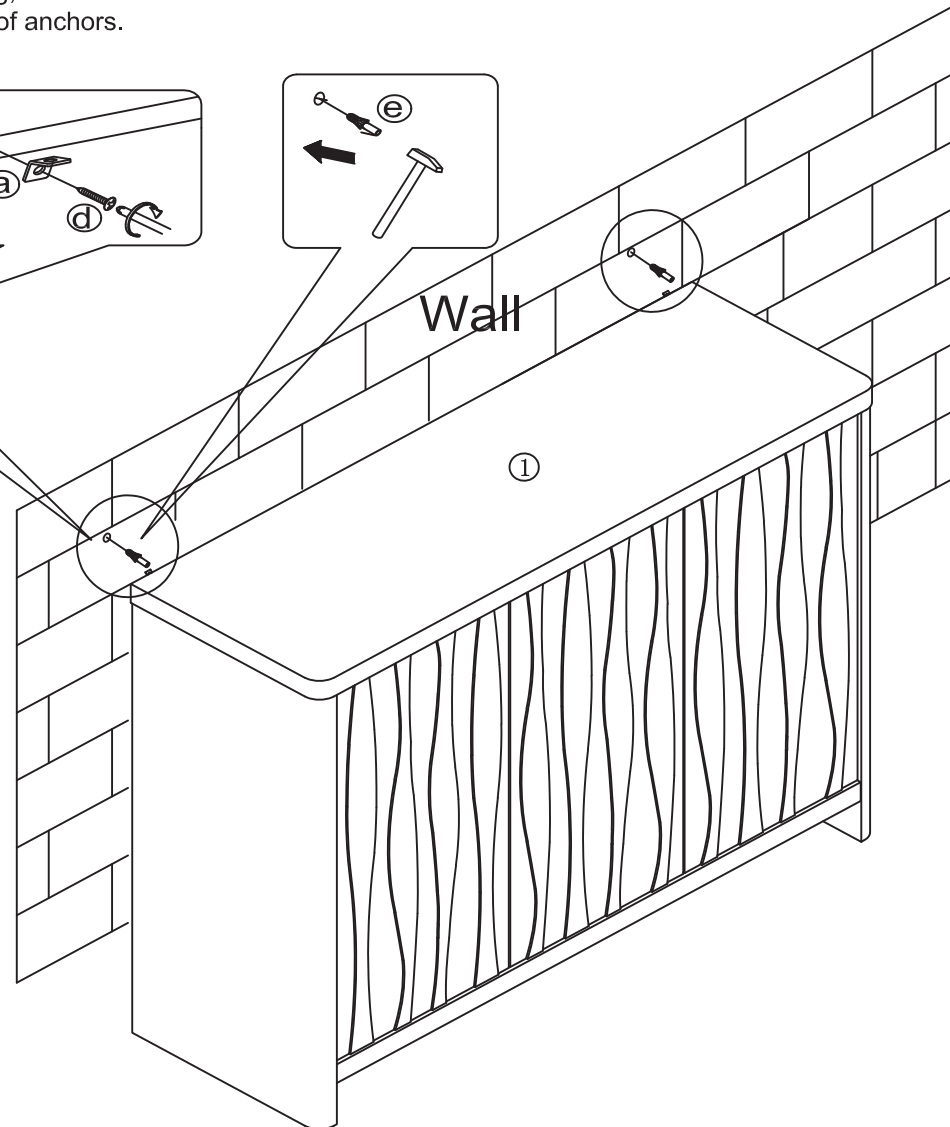
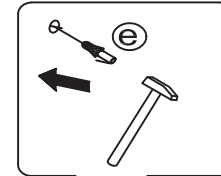
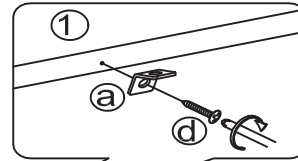
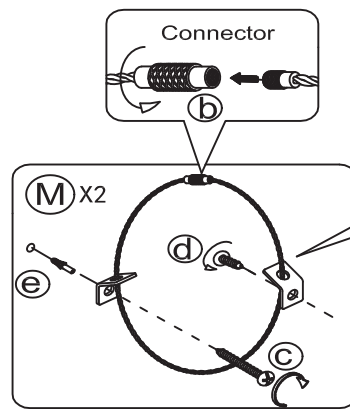
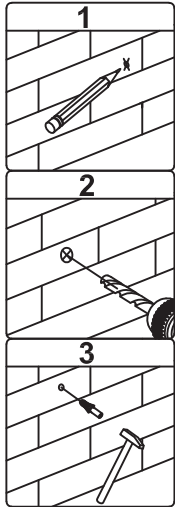

Adjusting the door

- Before adjusting the hinge, please check whether the cabinet is skewed.
- If the skew can not be repaired, please remove the anti-tipping device first, then adjust the cabinet to vertical position.
- Please adjust the hinge with the door open.
- Please operate it with more than 2 people, one person holds the door and the other one adjusts the screw.
- Have trouble adjusting the door? Please check out our video on adjusting the door via our website or contact care@oakhamdesign.com !

Components Name

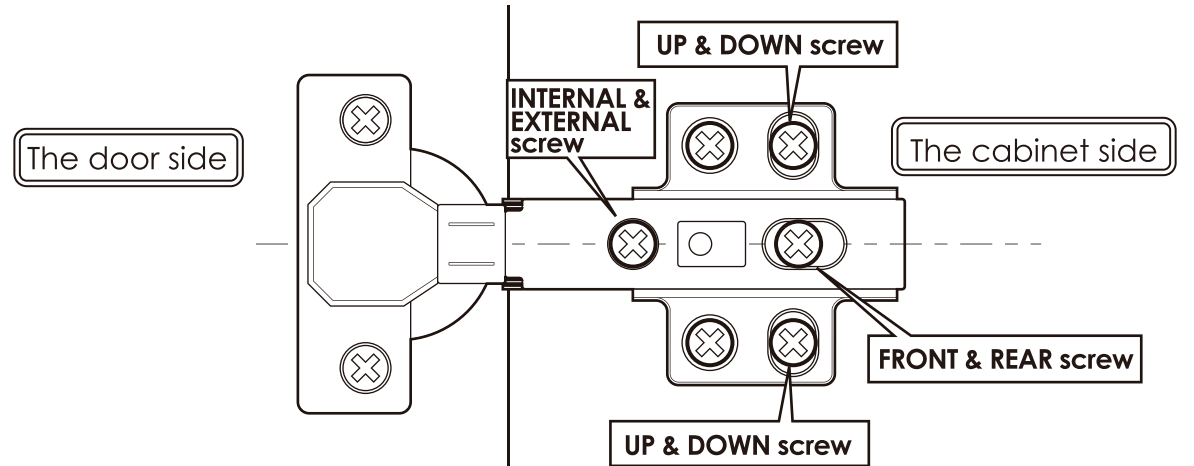

Obvious gaps between doors or Doors don't look closed

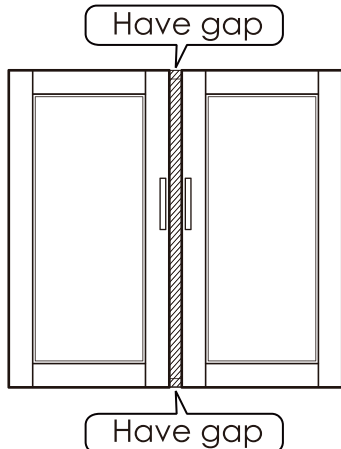

1 Turn "internal & external screw" to the right can make the door approach inside. Please adjust the doors little by little.

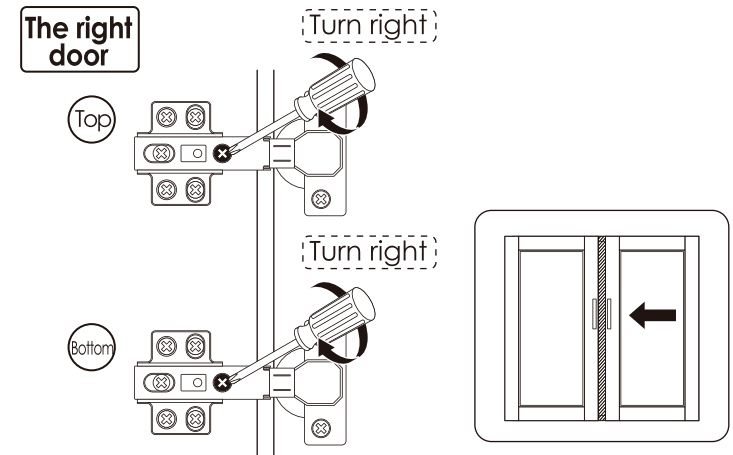
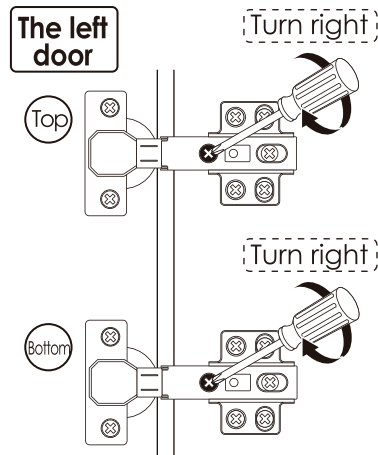

※ If the 2 doors are overlap, please turn the "internal & external screw" to the left.

When door is crooked



Please take the following steps to adjust first.

1 Rotate the "front and rear screws" to the left

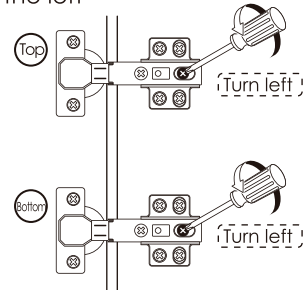

※ After adjusting the "front and rear screw", the door still does not change, please turn the "internal & external screw" to the right Slightly.

2 Push the door to the cabinet

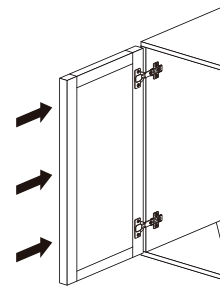

3 Rotate the "front and rear screws" to the right

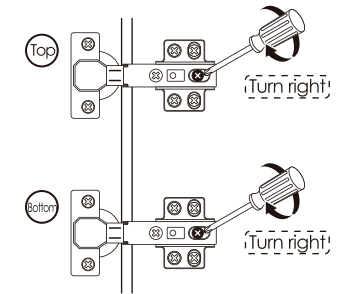

When door is leaning

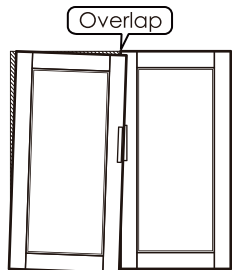

Protruding to the underside

1 Turn "internal & external screw" to the left can make the top of the door tilted outward.

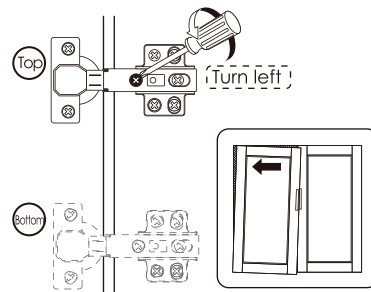

Protruding to the upside

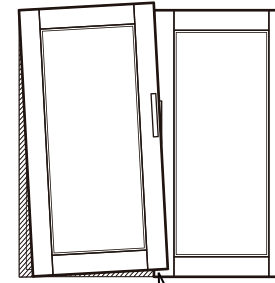

Overlap

1 Turn "internal & external screw" to the left can make the bottom of the door tilted outward.

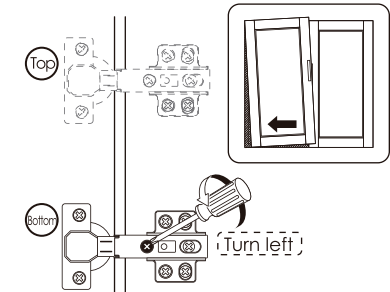

When the door is higher on top

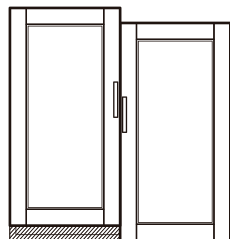

Have gap

1 Turn "up & down screw" to the left

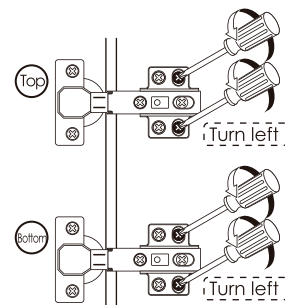

2 Lower the door's height so that 2 doors are of the same height.

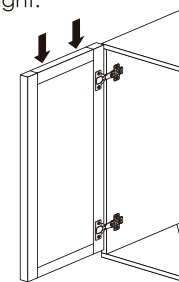

3 Turn "up & down screw" to the right

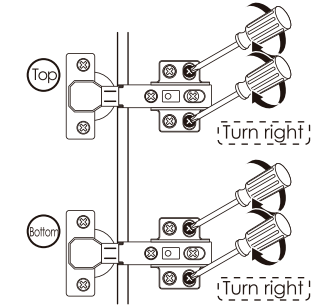

※ If the door is lower on bottom, please lift up the left door slightly on step 2

※ **Stay Scratch-Free: Safeguard Your Furniture by Assembling on Carpet.**

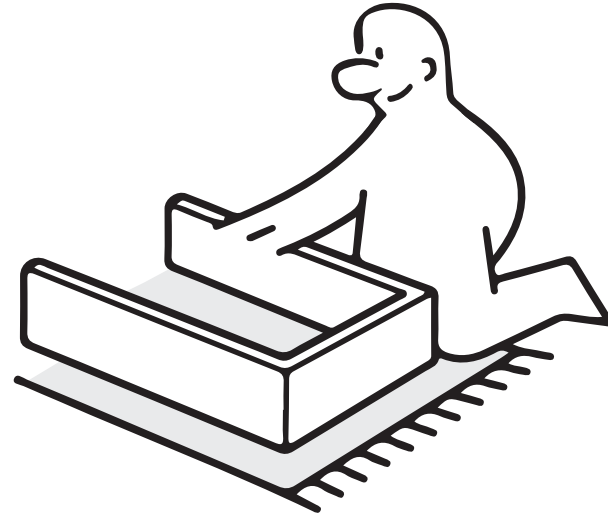
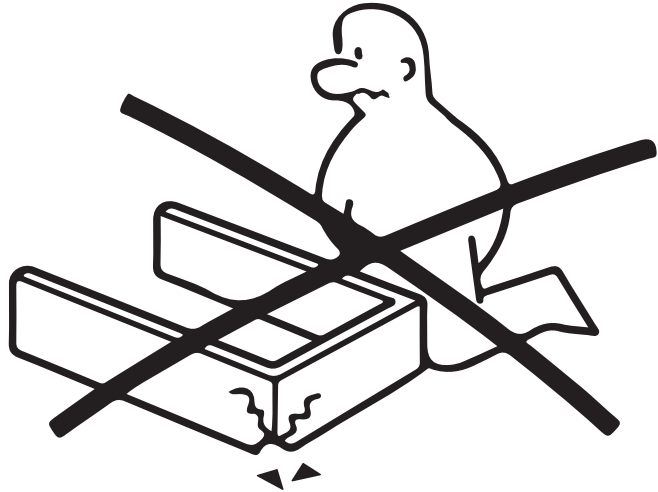

※ **Stuck in Assembly Limbo? Check out our website or contact our support team for quick solutions!**

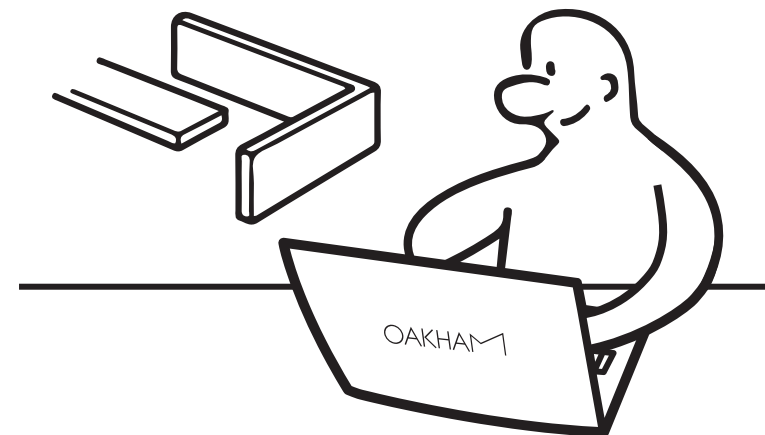
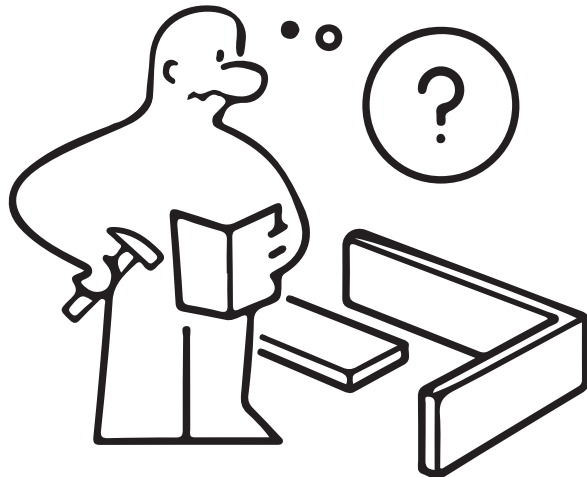

THANK YOU!

For purchasing from us

Despite our reinforced packaging, transit mishandling can sometimes occur. In the rare event that your product arrives damaged, we're here to assist you. **If your product is in perfect condition, you can disregard this message.**

If you discover any damage upon receipt of your package, please contact our after-sales mailbox immediately at care@oakhamdesign.com.

Additionally, we kindly request your assistance in filing a claim against the shipping carrier for the mishandling of your package. Please help us by providing clear photos as follows:

- ☆ Complete Shipping Label (Express Delivery Waybill): Take a clear image of the entire shipping label affixed to the package with visible and legible text and barcodes.
- ☆ Exterior Packaging Damage: Capture a comprehensive photo showing the damaged exterior of the shipping package.
- ☆ Interior Item Damage: Provide images focusing on the damaged areas of product

Your cooperation is invaluable, and we assure you that we're committed to resolving this issue promptly. Your satisfaction remains our top priority.

Thank you for your understanding and assistance.

Best regards,

Oakham Customer Support Team

care@oakhamdesign.com

Example:

