

# OAKHAM

## Hardware list

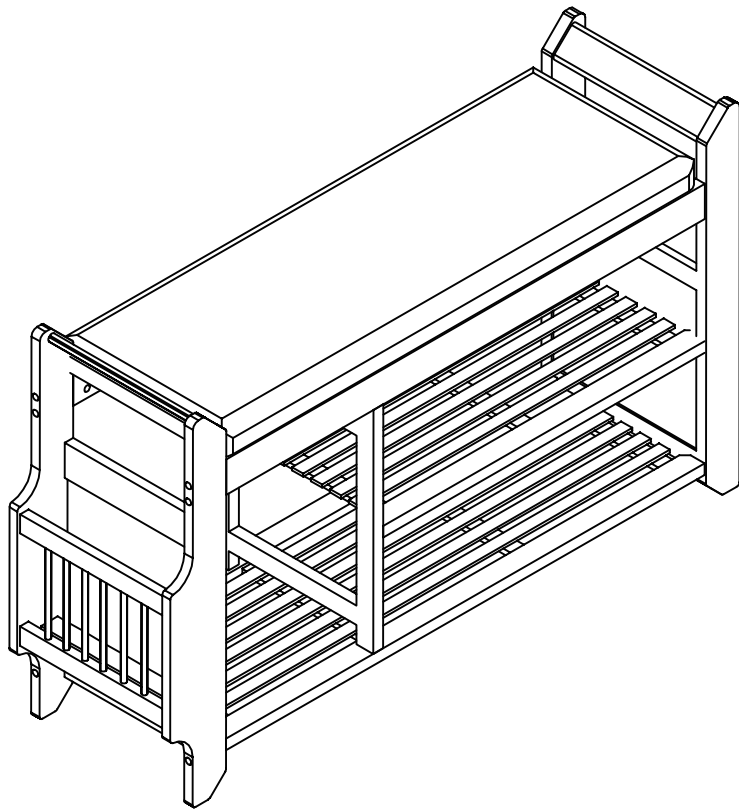

**A** x1

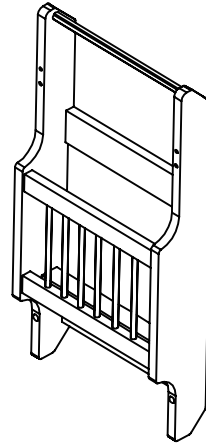

**B** x1

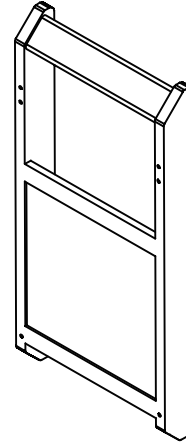

**C** x1

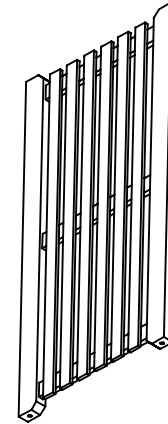

**D** x1

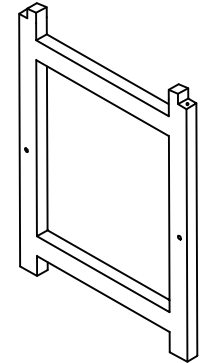

**E** x1

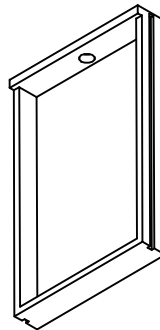

**F** x1



**G** x1

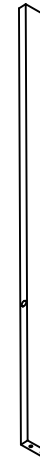

**H** x1

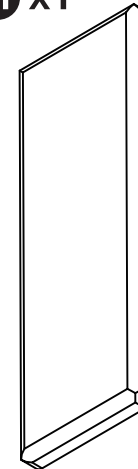

**I** x1

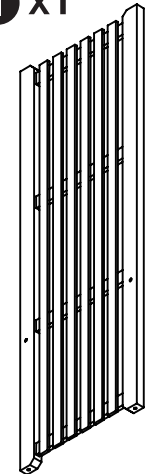

**J** x12



**K** x12



**L** x4

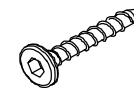

**M** x4



**N** x1



**O** x4



Video instructions can be found at:  
<https://oakhamdesign.com/pages/assembly-videos>

**Your satisfaction is our priority!**

If for any reason there is anything missing, incorrect, or different from your expectation, please contact us first at [care@oakhamdesign.com](mailto:care@oakhamdesign.com)

### Step 1

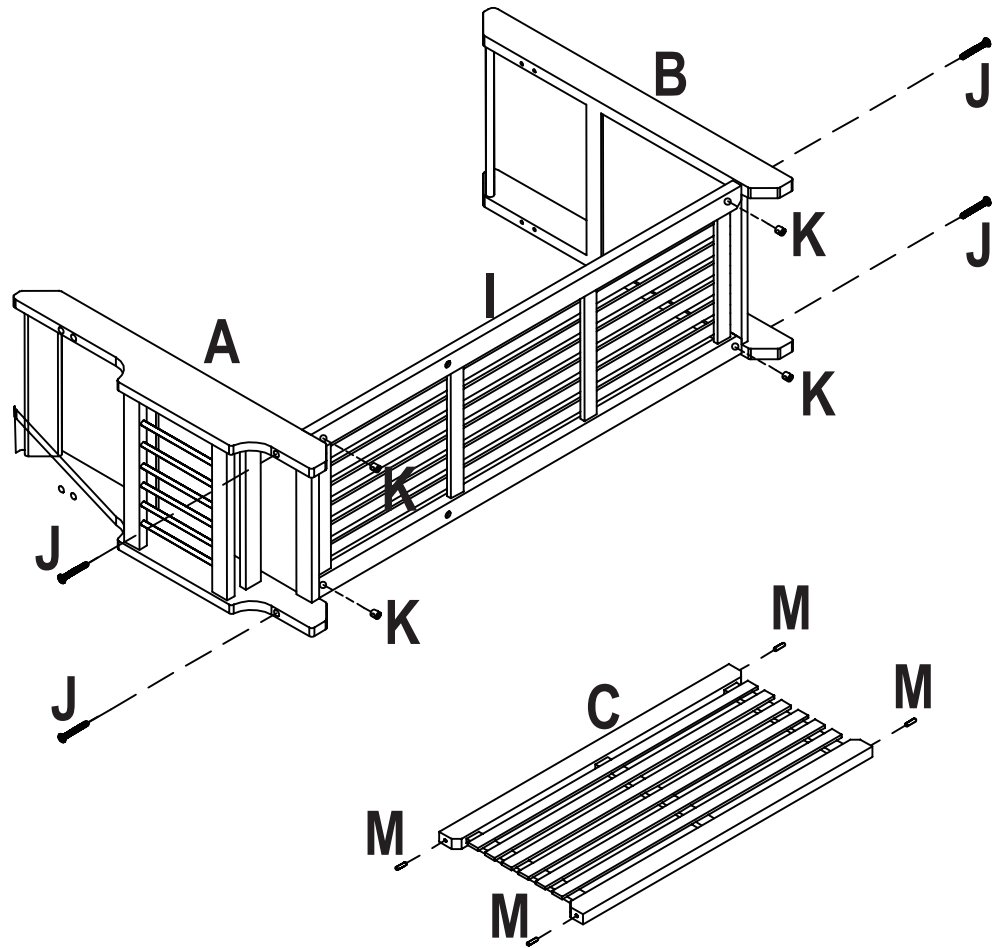

### Step 2

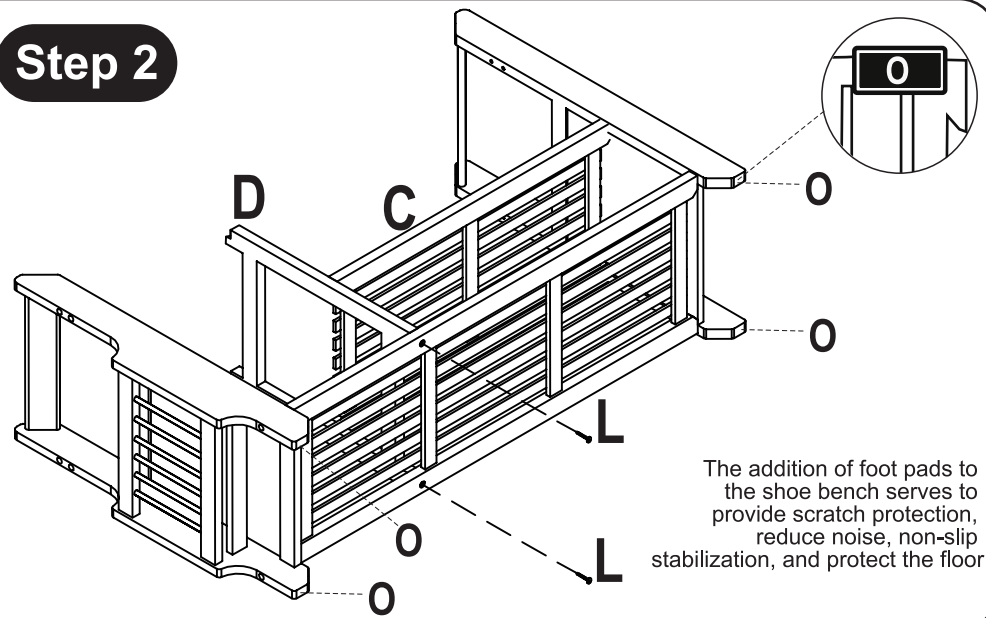

The addition of foot pads to the shoe bench serves to provide scratch protection, reduce noise, non-slip stabilization, and protect the floor

### Step 3

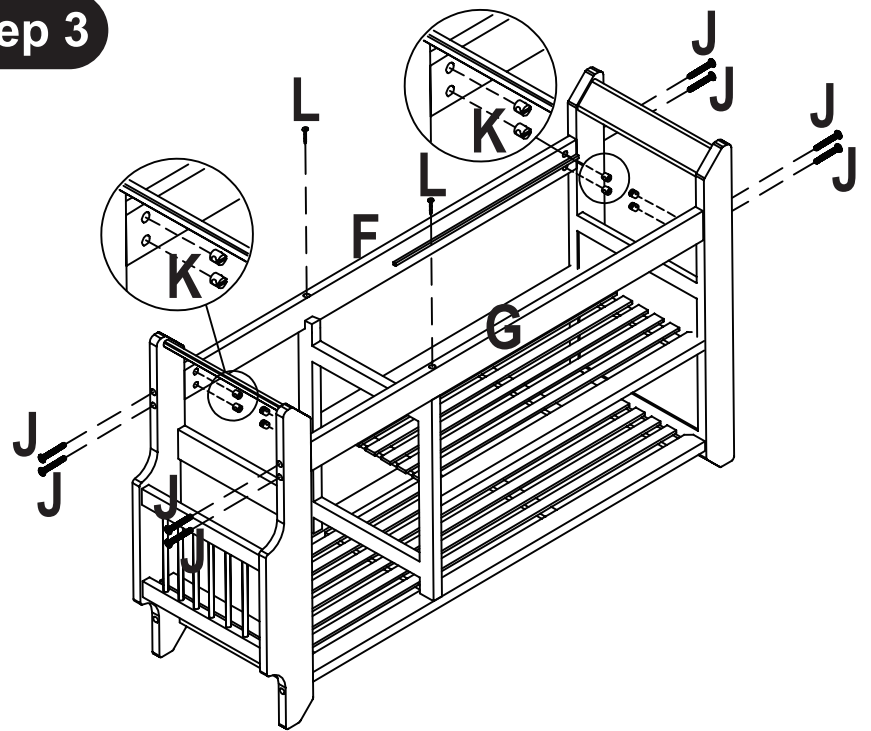

**Step 4**

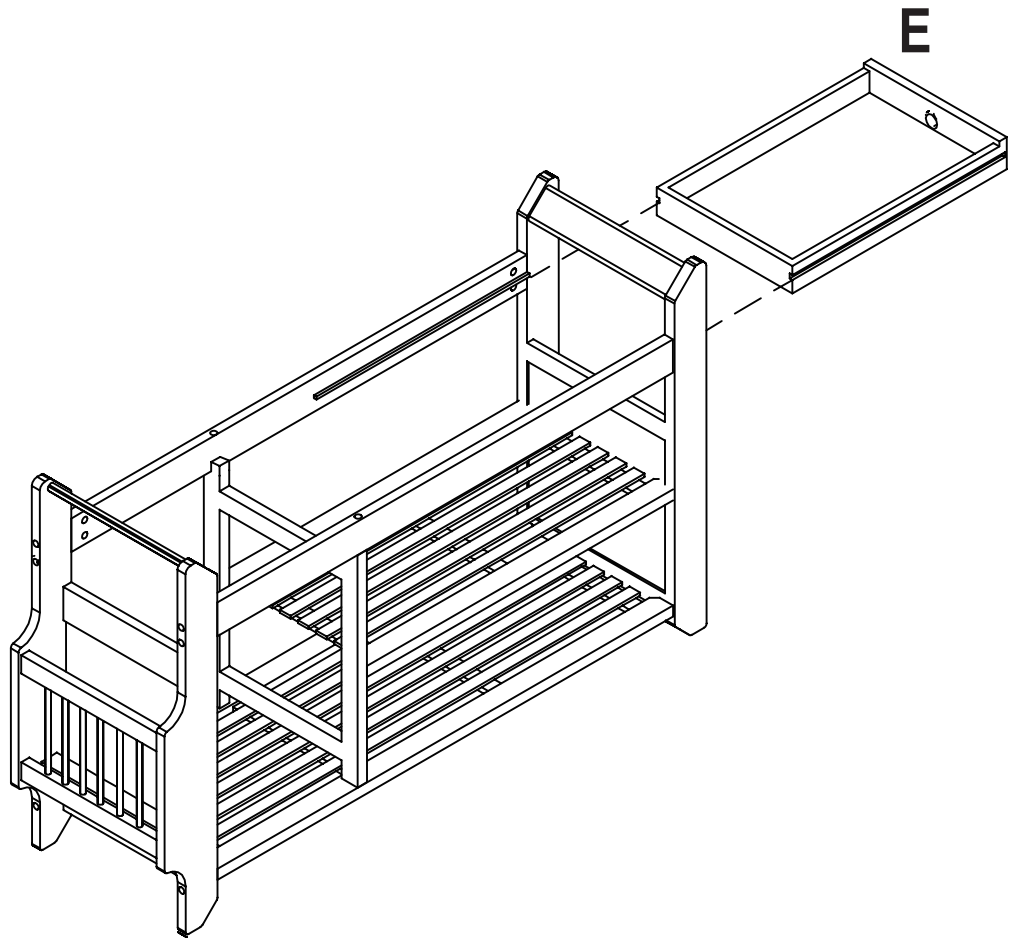

**Step 5**

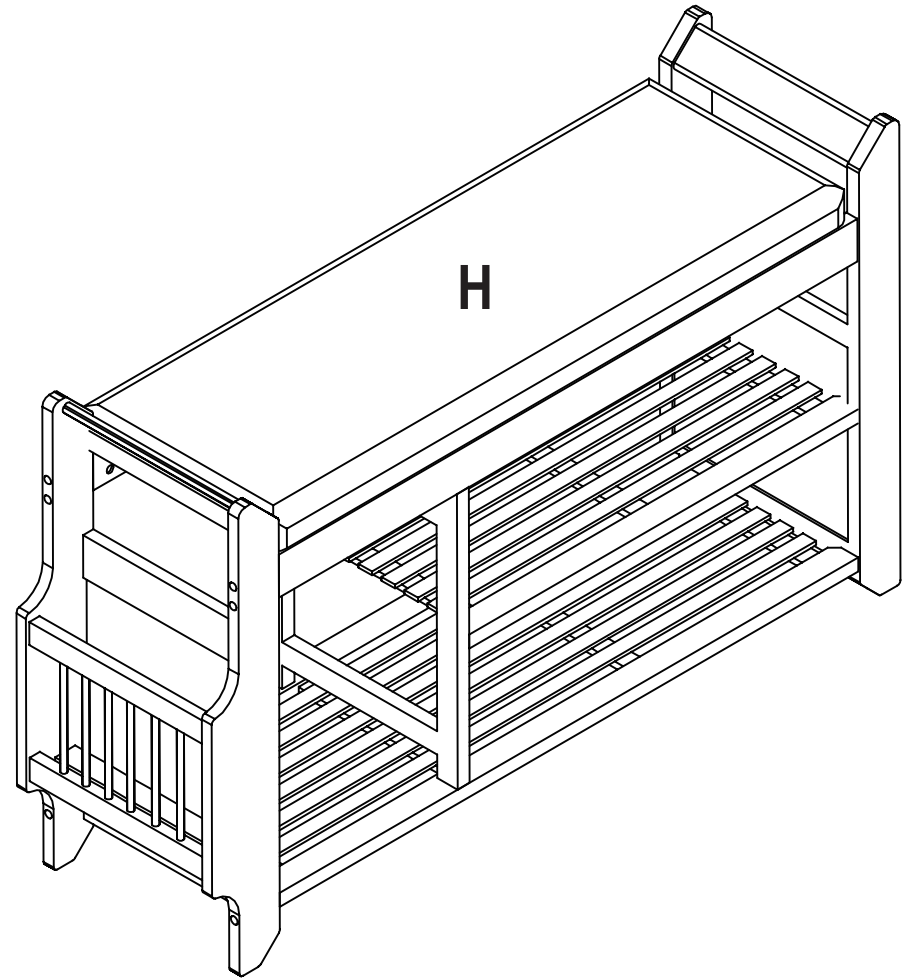

# THANK YOU!

## For purchasing from us

Despite our reinforced packaging, transit mishandling can sometimes occur. In the rare event that your product arrives damaged, we're here to assist you. **If your product is in perfect condition, you can disregard this message.**

If you discover any damage upon receipt of your package, please contact our after-sales mailbox immediately at [care@oakhamdesign.com](mailto:care@oakhamdesign.com).

Additionally, we kindly request your assistance in filing a claim against the shipping carrier for the mishandling of your package. Please help us by providing clear photos as follows:

- ☆ Complete Shipping Label (Express Delivery Waybill): Take a clear image of the entire shipping label affixed to the package with visible and legible text and barcodes.
- ☆ Exterior Packaging Damage: Capture a comprehensive photo showing the damaged exterior of the shipping package.
- ☆ Interior Item Damage: Provide images focusing on the damaged areas of product

Your cooperation is invaluable, and we assure you that we're committed to resolving this issue promptly. Your satisfaction remains our top priority.

Thank you for your understanding and assistance.

Best regards,

Oakham Customer Support Team

Example:

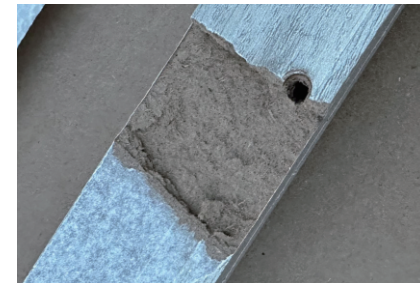

[care@oakhamdesign.com](mailto:care@oakhamdesign.com)