



**CONVENIENCE. ON THE GO.**

## ITEMS IN THE BOX

- ◆ Enclosed lockable Jerry Can Holder
- ◆ M8 Mounting Fasteners
- ◆ Wiring Extension Loom
- ◆ Cable ties for extension loom



## INSTALLATION GUIDE

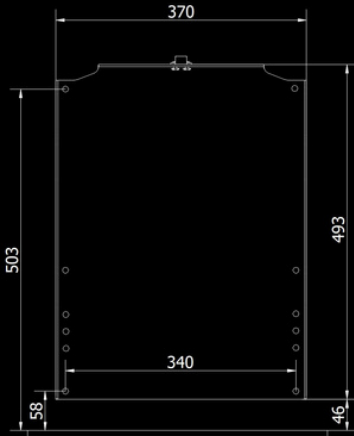

**BOLT POSITIONS**

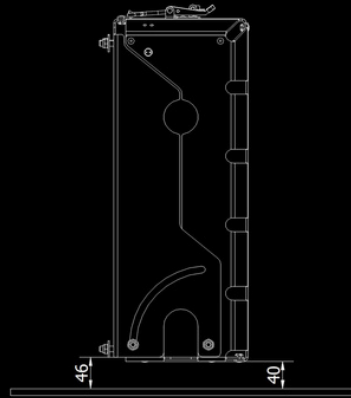

**SIDE VIEW - CLOSED**

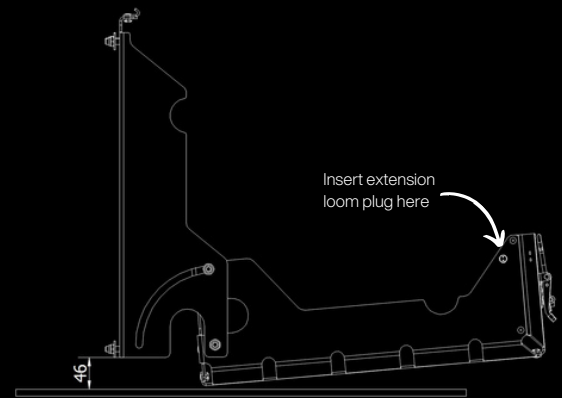

**SIDE VIEW - OPEN**

**PLEASE NOTE: IF INSTALLED DIRECTLY ABOVE TRAY OR SIMILAR, THE JERRY CAN HOLDER MUST BE SPACED UPWARDS A MINIMUM 40MM TO ALLOW CLEARANCE FOR THE CORRECT OPENING OF THE HOLDER.**

Please see drawings above, 40mm from the bottom of the unit when closed, or 46mm if measuring from the backplate.

## ASSEMBLY

- ◆ Remove all items from box.
- ◆ Position Jerry can holder for mounting, ensuring to leave sufficient gap underneath to allow opening.
- ◆ Mark final position, double check alignment and clearances to prevent binding and collisions.
- ◆ Mark and drill hole positions using a 9mm drill bit, deburr holes. Any of the pre cut holes may be used but it is best to utilise the 4 outside corners if possible as this spreads the load evenly.
- ◆ Install fasteners ensuring the round bolt heads are facing the jerry can. The large washers are intended to be used inside your canopy wall to prevent tear through.
- ◆ To prevent leaks, it is recommended to apply a small amount of silicone sealant to the bolts upon installation.
- ◆ Install wiring extension loom into the desired side of the Jerry Can Holder.
- ◆ Using 1 cable tie, fasten wiring to the inside roof of the holder to prevent damage when removing OnTap.
- ◆ With the Jerry Can Holder in the open position, lay your OnTap unit into the holder, connect your wiring to the electrical connector on the OnTap, close the holder and latch.
- ◆ Uncoil and connect power cord to the external plug just installed in the holder, connect hose and ENJOY.

## CARE INSTRUCTIONS

- ◆ This Jerry Can Holder requires very little maintenance, periodic checking of bolts and fasteners is sufficient.
- ◆ Latch tension can easily be adjusted by loosening the 10mm locking nut and turning the loop tighter or looser..
- ◆ Clean and wash as you would the rest of your vehicle, degrease and wash with a non corrosive detergent and avoid abrasive brushes or sponges.
- ◆ If fatigue or damage occurs please stop using the holder as it may cause injury to yourself or others if a container was to release.



# DRAWBAR/CARAVAN INSTALLATION GUIDE

## DRAWBAR BRACKET PARTS

- ◆ Stainless steel multi-fit brackets
- ◆ M8x75mm Extended bolts

**PLEASE NOTE: IF INSTALLED DIRECTLY ABOVE TRAY OR SIMILAR, THE JERRY CAN HOLDER MUST BE SPACED UPWARDS A MINIMUM 40MM TO ALLOW CLEARANCE FOR THE CORRECT OPENING OF THE HOLDER.**

Please see drawings above, 40mm from the bottom of the unit when closed, or 46mm if measuring from the backplate.

Alternative mounting option to previous page, intended for mounting to caravan or trailer bumper or drawbar (Bracket available separately)

This bracket is designed to suit square and rectangular box sections of 50x50mm 75x50mm and 100x50mm, sections thicker than this will require longer bolts.

The Jerry can holder features multiple sets of holes allowing fitment to any of the mentioned sized drawbars at 2 different height options.

## ASSEMBLY

- ◆ Position Jerry can holder for mounting, ensuring to leave sufficient gap underneath to allow opening.
- ◆ Mark final position, double check alignment and clearances to prevent binding and collisions.
- ◆ Insert longer bolts through corresponding holes of the Jerry Can Holder at your desired height option.
- ◆ Install fasteners ensuring the bolt heads are facing the jerry can, nyloc nuts on the bracket side. Ensure brackets are straight putting equal tension on each bolt to ensure correct fitment.

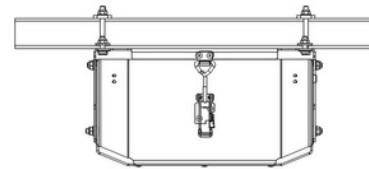
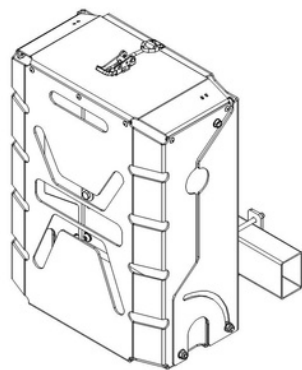

Example 75x50mm  
in "Low" position

