

Wood Chipper Operator's Manual

MODEL NUMBER : **TRA-0401**

SERIAL NUMBER :

Both model number and serial number may be found on the main label. You should record both of them in a safe place for future use.

FOR YOUR SAFETY

**READ AND UNDERSTAND THE ENTIRE MANUAL BEFORE
OPERATING MACHINE**

Customer Support (888) 680-2849, inquiry@bilthardusa.com

TABLE OF CONTENTS

Introduction	2
Specifications	2
Symbols	3
Safety	4
General Safety Rules	4
Specific Safety Rules	6
Contents supplied	8
Assembly	8
Know your Wood Chipper	11
Features & Controls	11
Operation	12
Transporting	15
Maintenance	15
Storage	19
Trouble Shooting	20
Parts Schedule	21
Engine Parts Schedule	23
Warranty	26

INTRODUCTION

The wood chipper is a power-driven machine for cutting wood into chips.

Your new wood chipper will more than satisfy your expectations. It has been manufactured under stringent quality standards to meet superior performance criteria. You will find it easy and safe to operate, and with proper care, it will give you many years of dependable service.



Carefully read through this entire operator's manual before using this unit. Take special care to heed the cautions and warnings.

Specifications, descriptions and illustrations in this manual are as accurate as known at the time of publication, but we are always working to improve our products. Therefore are subject to change without notice.

Specifications

Chipper-shredder Specifications

Item No.	TRA-0401
Engine	224cc EPA Approved
Chipping Capacity	3" dia.
Hooper Capacity	0.5"
Infeed Throat Opening	7.6"x2.9" / Ø3"
Feed Hopper Opening	9.7"x14.1" / Ø5.6"
Feed Type	Gravity
Number of Blades	2
Bag	Included
Packing Size	29.1"x19.1"x25.2"

Engine Specifications

Displacement.	224 cc
Type	4-Stroke OHV
Start Type	Recoil

Fuel Specifications

Use regular unleaded gasoline with a minimum octane rating of 87 and an ethanol content of less than 10% by volume. DO NOT USE E15 or E85. DO NOT OVERFILL.

Gasoline Capacity	0.9 gal. (3.5 L)
-------------------	------------------

Engine Oil Specifications

DO NOT OVERFILL.



The recommended oil type is 10W-30 automotive oil.

Type	See chart below
Capacity	20.3 fl. oz (600 ml)

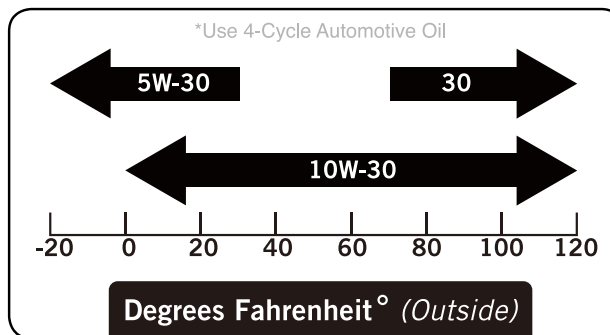

NOTICE

Weather will affect engine oil and engine performance. Change the type of engine oil used based on weather conditions to suit the engine needs.

Spark Plug Specifications

OEM Type	NHSP F6RTC
Replacement Type	NGK BPR6ES or equivalent
Gap	0.028-0.031 in.

Valve Specifications

Intake Clearance	0.005-0.007 in.
Exhaust Clearance	0.007-0.009 in.

Important Message About Temperature

Your product is designed and rated for continuous operation at ambient temperatures up to 104°F (40°C). When your product is needed it may be operated at temperatures ranging from 5°F (-15°C) to 122°F (50°C) for short periods of time. In any event, the product must always be operated outdoors, in a well-ventilated area and away from doors, windows and vents.

RECYCLING AND DISPOSAL



This marking indicates that this product should not be disposed with other household wastes. To prevent possible harm to the environment or human health from uncontrolled waste disposal, recycle it responsibly to promote the sustainable reuse of material resources. To return your used device, please use the return and collection systems or check with your local authority or local stores for advice of environmental safe recycling.

SYMBOLS

The rating plate on your machine may show symbols. These represent important information about the product or instructions on its use.



Read these instructions for use carefully.



Wear eye protection.



Wear hearing protection.



Wear protective gloves.



Wear safety footwear.



Do not remove or tamper with the protection and safety devices.



Do not touch parts which are hot from operation. Serious burns may result.



No smoking, No sparks, No flames.



Keep your hand and feet away from moving parts.



Thrown Objects.



Keep bystanders away.

SAFETY

General Safety Rules

Understand Your Machine

Read this manual and labels affixed to the machine to understand its limitations and potential hazards.

Be thoroughly familiar with the controls and their proper operation. Know how to stop the machine and disengage the controls quickly.

Make sure to read and understand all the instructions and safety precautions as outlined in the manual. Do not attempt to operate the machine until you fully understand how to properly operate and maintain the engine and how to avoid accidental injuries and/or property damage.

If the unit is to be used by someone other than original purchaser or loaned, rented, or sold, always provide this manual and any needed safety training before operation. The user can prevent and is responsible for accidents or injuries that may occur to themselves, other people, and property.

Do not force the machine. Use the correct machine for your application. The correct machine will do the job more efficiently and safer at the rate it was designed.

Personal Safety

Do not permit children to operate this machine at any time.

Keep children, pets, and other people not using the unit away from the work area. Be alert and shut off unit if anyone enters work area. Keep children under the watchful care of a responsible adult.

Do not operate the machine while under the influence of drugs, alcohol, or any medication that could affect your ability to use it properly.

Dress properly. Wear heavy long pants, boots, and gloves. Do not wear loose clothing, short pants, or jewelry of any kind. Secure long hair so it is above shoulder level. Keep your hair, clothing, and gloves away from moving parts. Loose clothes, jewelry, or long hair can be caught in moving parts.

Protect eyes, face, and head from objects that may be thrown from the unit. Always wear safety goggles or safety glasses with side shields when operating.

Wear appropriate hearing protection.

Always keep hands and feet away from all moving parts during operation. Moving parts can cut or crush body parts.

Always keep hands and feet away from all pinch points.

Do not touch parts that might be hot from operation. Allow parts to cool before attempting to maintain, adjust, or service.

Stay alert, watch what you are doing, and use common sense when operating the machine.

Do not overreach. Do not operate the machine while barefoot or when wearing sandals or similar lightweight footwear. Wear protective footwear that will protect your feet and improve your footing on slippery surfaces. Keep proper footing and balance at all times. This enables better control of the machine in unexpected situations.

Inspect Your Machine

Check your machine before starting it. Keep guards in place and in working order. Make sure all nuts, bolts, etc., are securely tightened.

Never operate the machine when it is in need of repair or is in poor mechanical condition. Replace damaged, missing, or failed parts before using it. Check for fuel leaks. Keep the machine in safe working condition.

Do not use the machine if the engine's switch does not turn it on or off. Any gasoline powered machine that can't be controlled with the engine switch is dangerous and must be replaced.

Regularly check to see that keys and adjusting wrenches are removed from the machine area before starting it. A wrench or a key that is left attached to a rotating part of the machine may result in personal injury.

Avoid accidental starting. Be sure the engine's switch is off before transporting the machine or performing any maintenance or service on the unit. Transporting or performing maintenance or service on a machine with its switch on invites accidents.

If the machine should start to vibrate abnormally, stop the engine (motor) and check immediately for the cause. Vibration is generally a warning sign of trouble.

Engine Safety

This machine is equipped with an internal combustion engine. Do not use on or near any unimproved, forest covered, or brush covered land unless the exhaust system is equipped with a spark arrester meeting applicable local, state, or federal laws.

In the state of California, a spark arrester is required by law. Other states have similar laws. A spark arrester, if used, must be maintained in effective working order by the operator.

Never start or run the engine inside a closed area. The exhaust fumes are dangerous, containing carbon monoxide, an odorless and deadly gas. Operate this unit only in a well-ventilated outdoor area.

Do not tamper with the engine to run it at excessive speeds. The maximum engine speed is preset by the manufacturer and is within safety limits.

Keep a Class B fire extinguisher on hand when operating this chipper in dry areas as a precautionary measure.

Fuel Safety

Fuel is highly flammable, and its vapors can explode if ignited. Take precautions when using to reduce the chance of serious personal injury.

When refilling or draining the fuel tank, use an approved fuel storage container while in a clean, well-ventilated outdoor area. Do not smoke, or allow sparks, open flames, or other sources of ignition near the area while adding fuel or operating the unit. Never fill the fuel tank indoors.

Keep grounded conductive objects, such as tools, away from exposed, live electrical parts and connections to avoid sparking or arcing. These events could ignite fumes or vapors.

Always stop the engine and allow it to cool before filling the fuel tank. Never remove the cap of the fuel tank or add fuel while the engine is running or when the engine is hot. Do not operate the machine with known leaks in the fuel system.

Never overfill the fuel tank. Fill the tank to no more than 1cm below the bottom of the filler neck to provide space for expansion as the heat of the engine can cause fuel to expand.

Replace all fuel tank and container caps securely and wipe up spilled fuel. Never operate the unit without the fuel cap securely in place.

Avoid creating a source of ignition for spilled fuel. If fuel is spilled, do not attempt to start the engine but move the machine away from the area of spillage and avoid creating any source of ignition until fuel vapors have dissipated.

When fuel is spilled on yourself or your clothes, wash your skin and change clothes immediately.

Store fuel in containers specifically designed and approved for this purpose.

Store fuel in a cool, well-ventilated area, safely away from sparks, open flames, or other sources of ignition.

Never store fuel or a machine with fuel in the tank inside a building where fumes may reach a spark, open flame, or any other source of ignition, such as a water heater, furnace, or clothes dryer. Allow the engine to cool before storing in any enclosure.

Specific Safety Rules

Identify hazards and take preventive steps to avoid accidents and minimize risk. Possible hazards include, but are not limited to, moving parts, thrown objects, weight of the machine and components, and the operating environment.

Prior to Starting

Thoroughly inspect the area in which you are working, keeping it clean and free of debris to prevent tripping. Operate on a flat level ground.

Before starting your chipper: make sure the feed hopper and cutting housing are empty and free of all debris, check the oil level, make sure all nuts and bolts are tight.

Operation Safety

Never place any part of your body where it would be in danger if movement should occur during assembly, installation, operation, maintenance, repair, or moving.

Keep all bystanders and pets at least 75 feet away. If you are approached, stop the unit immediately.

Never place your hands, feet, or any part of your body in the chipper hopper, discharge opening, or near or under any moving part while the machine is running. Keep the area of discharge clear of people, animals, buildings, glass, or anything else that will obstruct clear discharge, causing injury or damage. Wind can also change discharge direction, so be aware. If it becomes necessary to push materials to the chipper hopper, use a small-diameter stick, not your hands.

Keep your face and body back from the chipper hopper and discharge chute to avoid injury from accidental bounce back of material.

Never reach with your hands inside the feed hopper past the rubber flap while operating the machine.

Keep combustible substances away from the engine when it is hot.

Do not tilt the machine while the engine is running.

Never operate this machine without the feed hopper or discharge chute properly attached.

Operating Zone

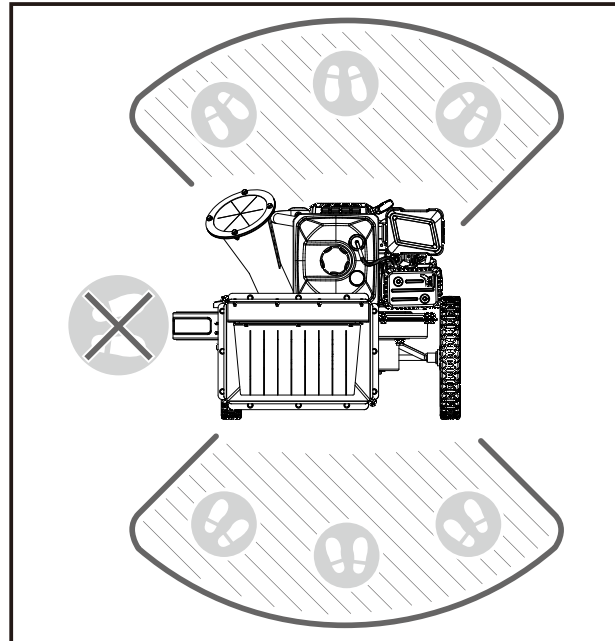

Feeding Materials

Feed only clean materials into the machine. Foreign matter such as soil, sand, grit, stones, pieces of metal, etc. will damage the sharp edge of the cutting knives. Root balls and dead wood will also dull the blades quickly.

NOTE: Wet material is easy to block the machine, so please do not put in.

Avoid feeding pine needles, flax and cabbage tree leaves into the machine; these stringy materials can wrap around the rotor shaft and work their way into the bearing.

Avoid feeding short, stubby pieces of wood into the machine; they tend to bounce and spin in the feed hopper. Feed these short pieces together with longer pieces. After becoming familiar with the machine, prune to suit its capabilities.

This machine is self-feeding, do not force branches into the blades. Allow the machine to automatically feed through. **Allow time for the machine to reach the highest spinning revolutions before feeding the next load of branches.**

Unclogging

Never allow processed material to build up in the discharge area. This can prevent proper discharge and result in kickback from the chipper hopper.

Never attempt to unclog either the feed hopper or discharge chute while the engine is running. Immediately shut off the engine, allow the cutting disk to come to a complete stop, and then remove the clogged material. Inspect for damage and check for any loose parts for repair or replacement.

Whenever you leave the operating position or if you have to remove processed material, leaves, or debris from the machine, always shut down the engine, and ensure the engine is switched to “off” to prevent accidental starting, and wait for all moving parts to come to a complete stop.

Before opening the cutting disk housing, always make sure the engine is switched off, the cutting disk is at a complete standstill.

Moving

Move the machine at least 10 feet away from the refueling point before starting engine.

This chipper is for movement by hand only. Never attempt to tow the machine on public highways, roads, or thoroughfares.

Machine Use And Care

Position the machine in such a way that it can not move during maintenance, cleaning, adjustment, assembly of accessories or spare parts, as well as under storage.

Do not force the machine. Use the correct machine for your application. The correct machine will do the job better and safer at the rate for which it is designed.

Do not change the engine governor settings or over-speed the engine. The governor controls the maximum safe operating speed of the engine.

Do not run the engine at a high speed when you are not working.

Do not put hands or feet near rotating parts.

This machine has two rotating cutting knives capable of amputating hands and feet and throwing objects. Keep hands and feet out of openings while machine is running. Failure to

observe these safety instructions could result in serious injury or death.

Avoid contact with hot fuel, oil, exhaust fumes and hot surfaces. Do not touch the engine or muffler. These parts get extremely hot from operation. They remain hot for a short time after you turn off the unit. Allow the engine to cool before doing maintenance or making adjustments.

If the machine should start to make an unusual noise or vibration, immediately shut off the engine, disconnect the spark plug wire, and check for the cause. Unusual noise or vibration is generally a warning of trouble.

Use only attachments and accessories approved by the manufacturer. Failure to do so can result in personal injury.

Keep the engine and muffler free of grass, leaves, excessive grease or carbon build up to reduce the chance of a fire hazard.

Never douse or squirt the unit with water or any other liquid. Keep handles dry, clean and free from debris. Clean after each use.

Observe proper disposal laws and regulations for gas, oil, etc. to protect the environment.

When storing machine out of the reach of children and do not allow persons unfamiliar with the machine or these instructions to operate it. This machine can be dangerous when used by an untrained user.

Maintaining Your Machine

Some parts of this machine are made of plastic or rubber and should be kept away from chemicals.

Never cover the machine while the muffler is still hot.

Do not alter or adjust any part of the chipper or its engine that is sealed by the manufacturer or distributor. Only a qualified service technician may adjust parts that increase or decrease governed engine speed.

To maintain your machine, check for any misalignment or binding of any moving parts. Parts that are broken or worn down may affect the machine's operation. If damage or worn parts are identified, they should be repaired before use. Many accidents are caused by poorly maintained equipment.

CONTENTS SUPPLIED

The wood chipper comes partially assembled and is shipped in carefully packed package. After all the parts have been removed from the package, you should have:

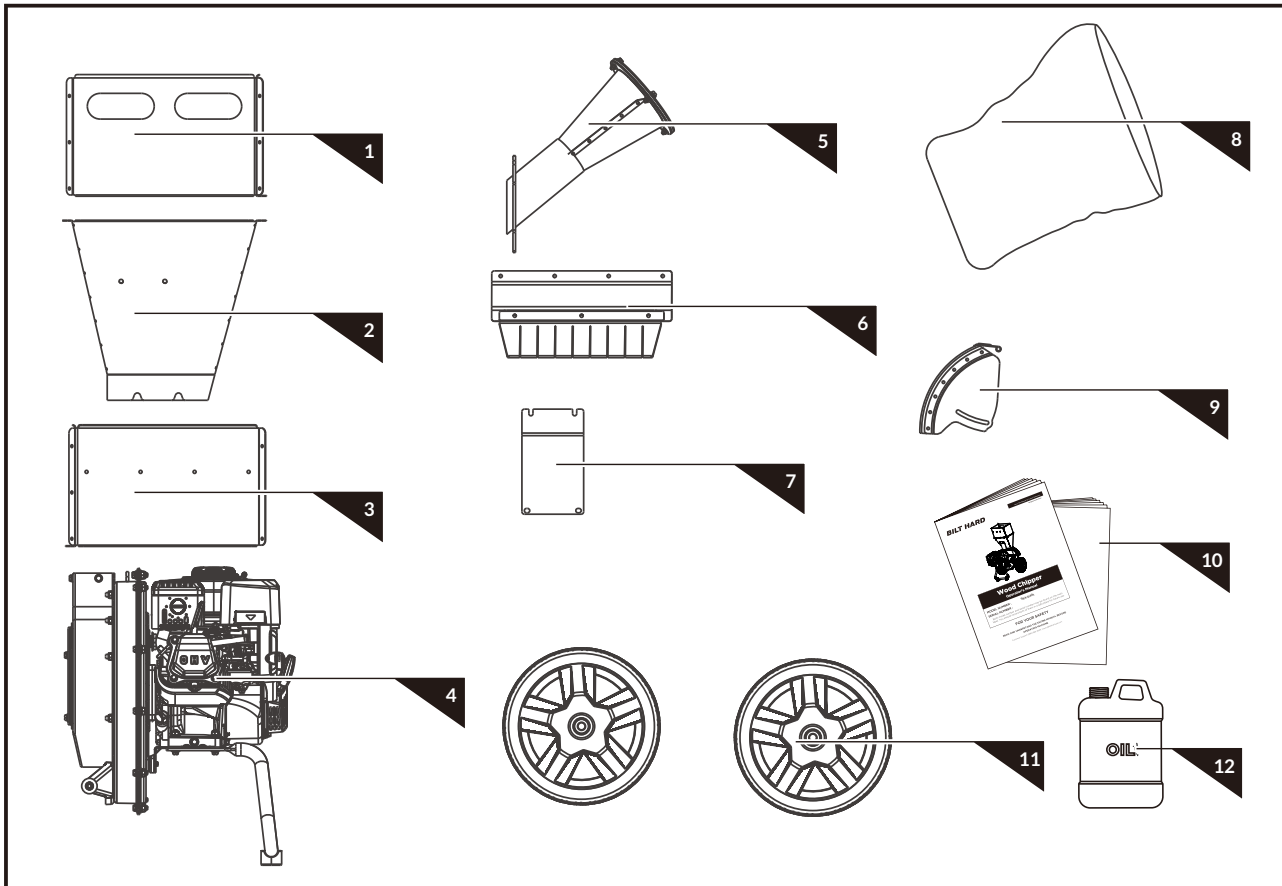

- | | |
|---------------------------|------------------------|
| 1.Right Heightening Plate | 7.Support Plate |
| 2.Hopper | 8.Discharge Bag |
| 3.Left Heightening Plate | 9.Discharge Port Cover |
| 4.Engine | 10.Operator's Manual |
| 5.Chipper Chute | 11.Wheels |
| 6.Baffle | 12.Oil (600ml) |

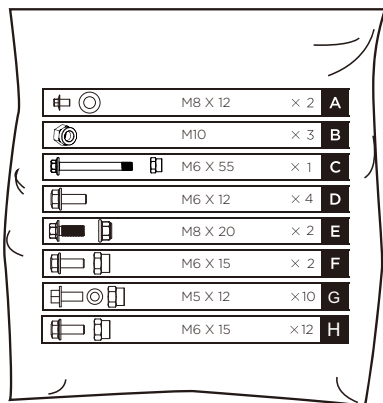

ASSEMBLY

Following the assembly directions below, you will assemble the machine in a few minutes.

Wheels

1. Install the Wheel: Thread the 2 wheels on the wheel shaft and screw the M8x12 bolt and washer(A) into the wheel shaft end to secure the wheels in place.

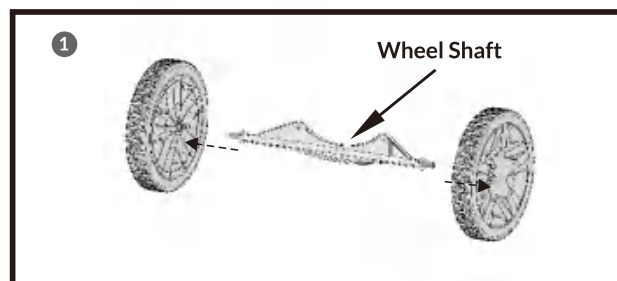

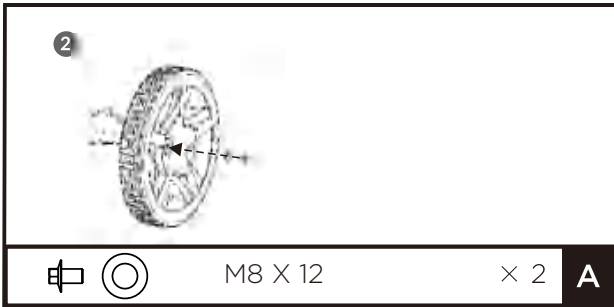

Chipper Chute

Install the Chipper Chute: Position the chipper chute over the three threaded studs protruding from the fixed plate, and attach using three M10 nuts(B) nuts to lock the chipper chute.

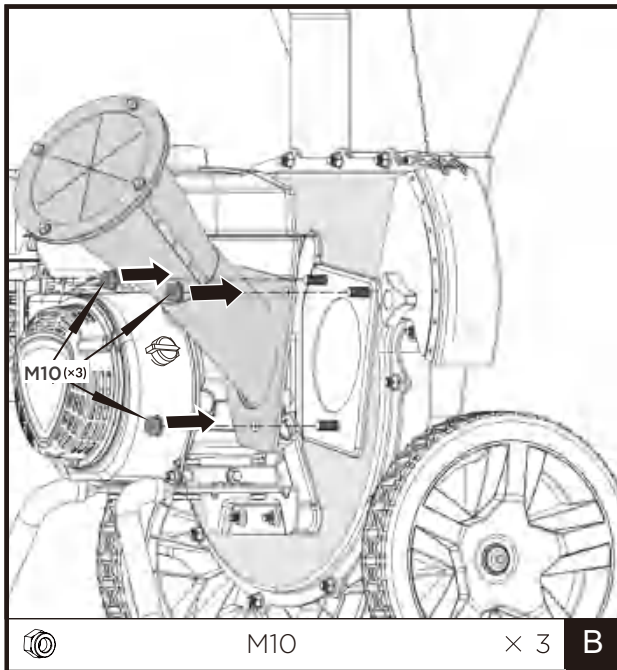

Deflector

Install the Discharging Cover: Insert the M6x55 bolt(C) into the mounting hole of the discharging cover, the shell and the fixed plate, then use M6 nut to lock; Adjust the discharge cover to the appropriate height, and attach the knob to the discharge cover, then use nut to lock the discharging cover.

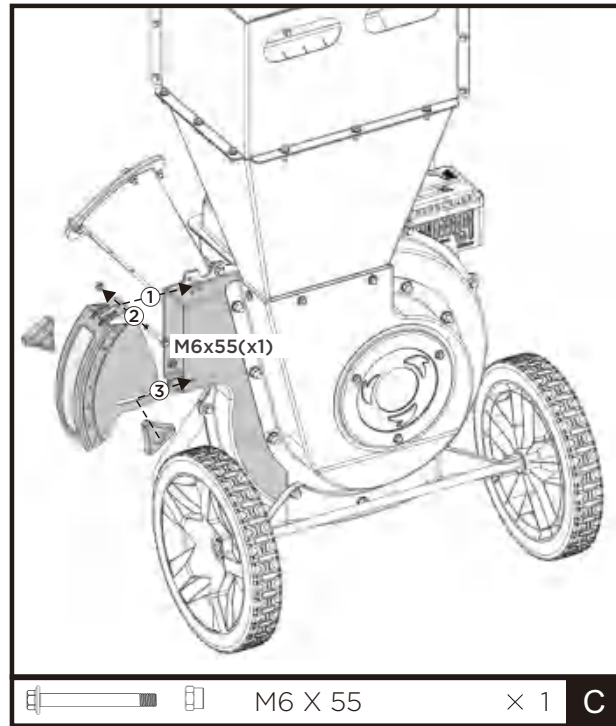

1. Install the Hopper: Put the hopper into the lower cover and align with the mounting hole, then secure the hopper with four M6x12 bolts(D)
2. Use two M8x20 bolts(E) to go through the mounting hole of fixed plate and support plate, then use M8 nuts to secure.
3. Insert two M6x15 bolts(F) into the mounting holes of the hopper, then through the mounting holes of the support plate, and tighten them with two M6 nuts. Tighten M8 bolts and nuts of the fixed plate and support plate; Tighten M6 bolts between the hopper and the lower cover.

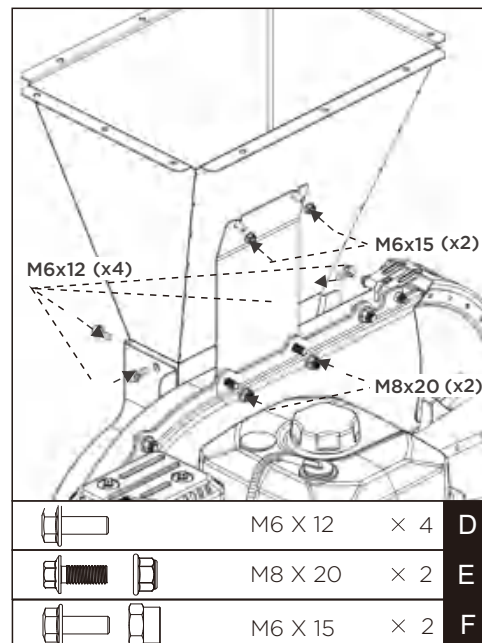

1. Combine the left heightening plate and baffle: align with mounting holes; Insert four M5x12 bolts(G) into the mounting hole from the outside of the left heightening plate and tighten them with four M5 nuts: Fix the baffle on the left heightening plate.
2. Combine the right heightening plate
Align with screw holes of left and right heightening plates, insert six M5x12 bolts(G) into mounting holes from the front side of the right heightening plate (the side with the handle hole), and thread on the six M5 nuts, do not tight.

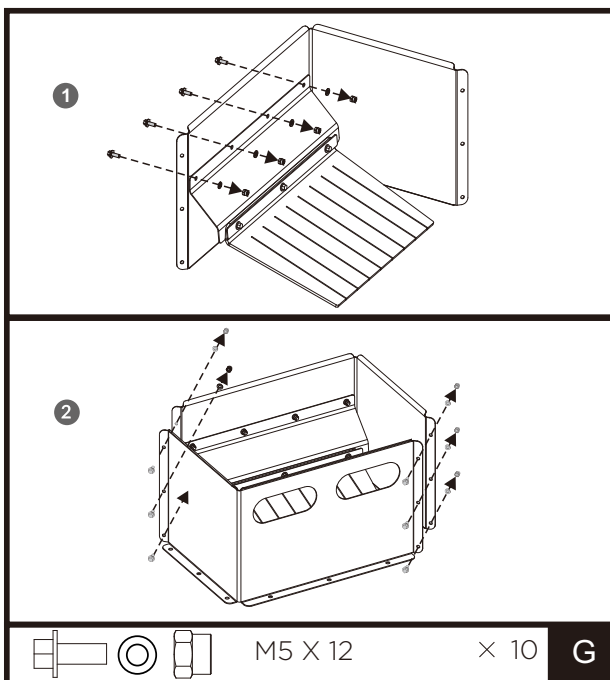

Install the heightening plate: Put the combination of heightening plates on the upper hopper, as far as possible aligned with the mounting hole; Thread twelve M6x15 bolts (H) through mounting holes on the side of the heightening plate, and tighten them with twelve M6 nuts; Finally tighten M5 bolts and nuts between the left and right heightening plates.

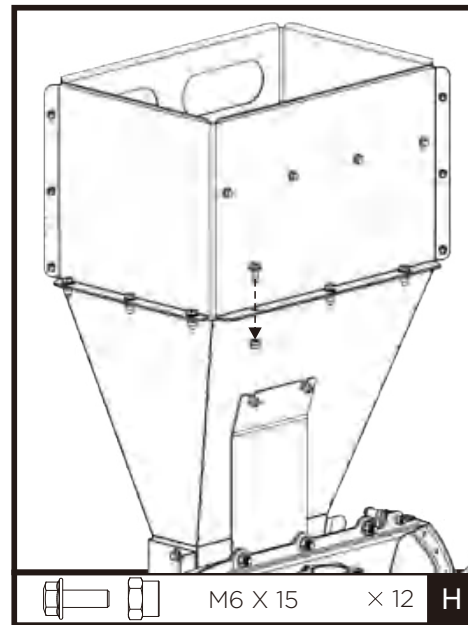

Collection Bag

1. Loosen the adjusting wing nut to set the discharge shoot door.
2. Open the debris bag and slip the opening of the debris bag over the discharge chute housing.
3. strap.

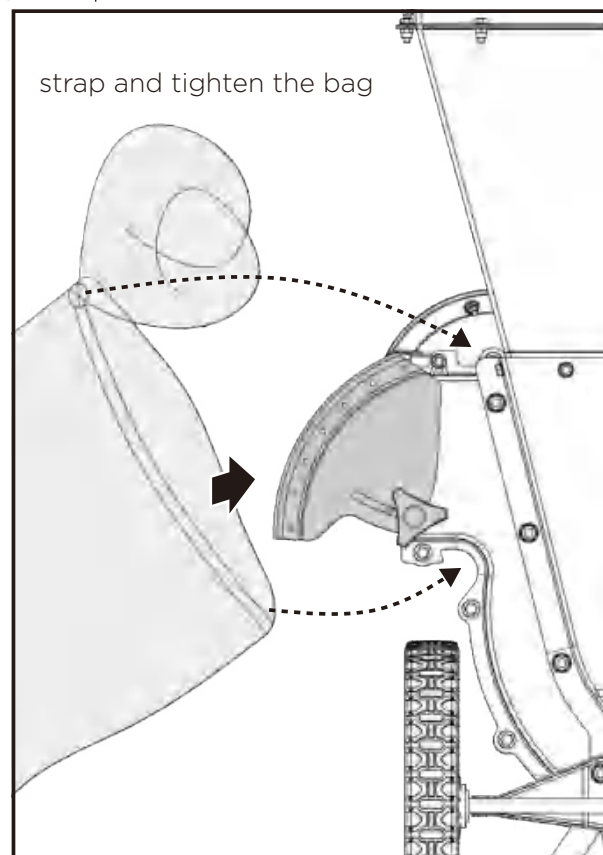

KNOW YOUR Wood Chipper

Features and Controls

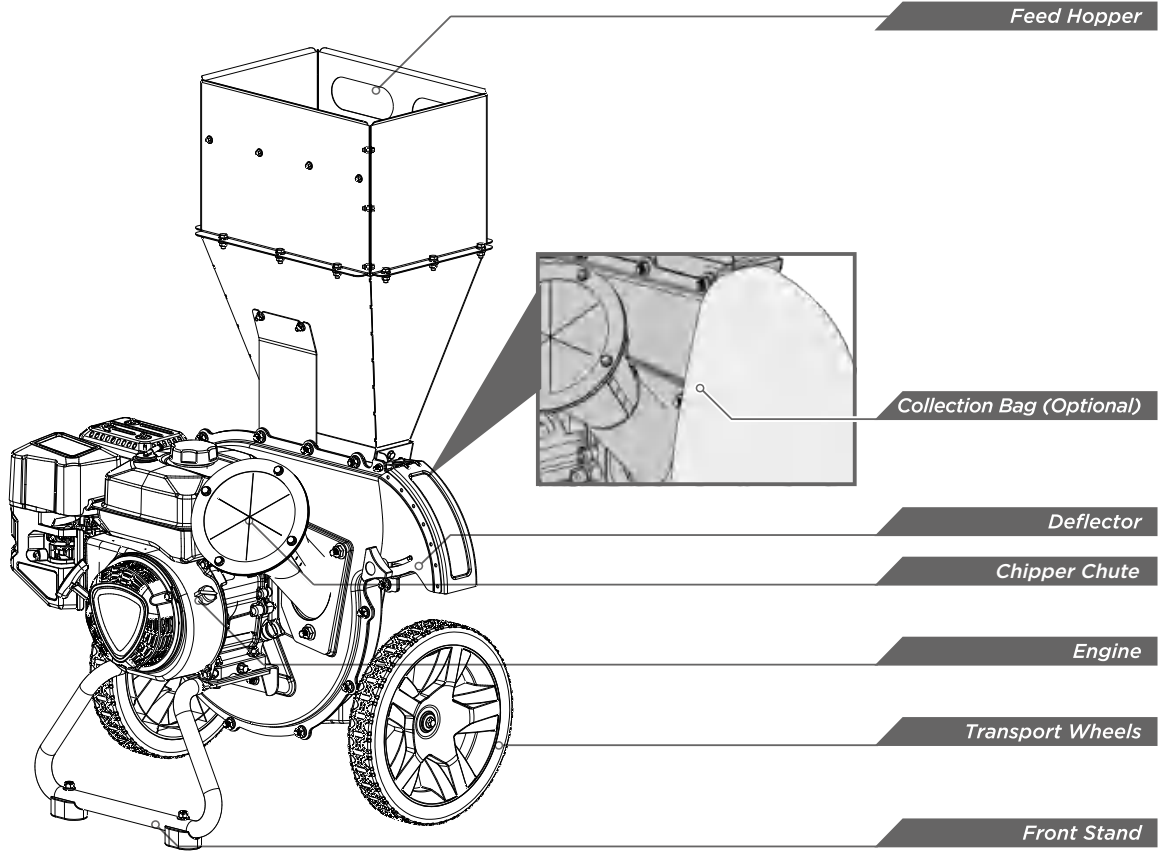

Choke Control

Engine On/Off Switch

Fuel Shut-Off Valve

Recoil Starter Handle

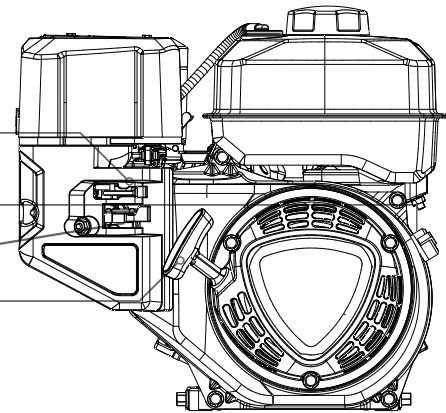

Feed Hopper

The Feed Hopper is on top of the unit. Always load leaves and other light waste into the hopper opening. Material maximum diameter 0.5inch(1.3cm).Never insert hands into the hopper opening.

Chipper Chute

The Chipper Chute is located on the front of the unit, and next to the engine. Insert branches and tree limbs no larger than 7.6cm (3") in diameter into the chipper chute opening. Never insert hands past the cone opening.

Collection Bag

The Collection Bag captures all debris discharged from the unit. Secure the collection bag before operate the unit.

Deflector

Chipped debris are discharged through the Deflector opening.

Grip Handles

The handles are used to move the unit.

Transport Wheels

To move the chipper, grip the handles located on the top of the opening of the hopper and tilt the machine back until it is fully resting on the tires.

Engine On/Off Switch

The engine switch has two positions. OFF - engine will not start or run. ON - engine will start and run.

Recoil Starter Handle

The handle is used to start the engine.

Fuel Shut-Off Valve

The fuel shut off lever has two positions: Open (🔲) and Closed (🔳). Use the Open position when operating, and use the closed position for servicing, transporting, or storing the unit. OPEN (🔲) - use this position to run the unit.

Choke Control

The choke control is used to choke the carburetor and assist in starting the engine. The choke control slides between the START |↘| and RUN |↑| positions.

Wood Chipper Operation



The engine is shipped without oil. Do not start the engine before adding oil.

Add Oil To Engine



DO NOT attempt to crank or start the engine before it has been properly filled with the recommended type and amount of oil. Damage to the wood chipper as a result of failure to follow these instructions will void your warranty.



The recommended oil type is 10W-30 automotive oil.

1. Place the wood chipper on a flat, level surface.
2. Remove oil fill cap/dipstick to add oil.
3. Add up to 20.3 fl.oz.(600ml) of oil (not included) and replace oil fill cap/dipstick. DO NOT OVERFILL.
4. Check engine oil level daily and add as needed.

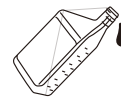

Note: Oil dipstick is blue color

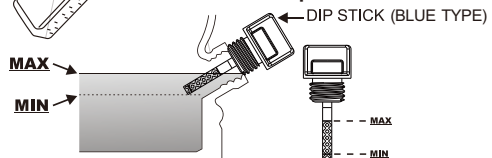

*Use 4-Cycle Automotive Oil

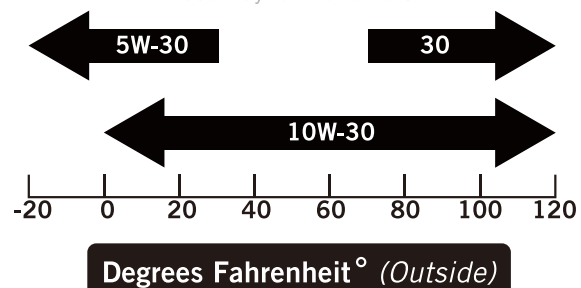

Check oil often during the break-in period. Refer to the Maintenance section for recommended service intervals.



The engine is equipped with a low oil shut-off and will stop when the oil level in the crankcase falls below the threshold level.

Add Gasoline To Engine

1. Use clean, fresh, regular unleaded fuel with a minimum octane rating of 87 and an ethanol content of less than 10% by volume.
2. DO NOT mix oil with fuel.
3. Clean the area around the fuel cap.
4. Remove the fuel cap.
5. Slowly add the fuel in the tank. DO NOT fill fully. Add fuel until reach the red line.
6. Screw on the fuel cap and wipe away any spilled fuel.

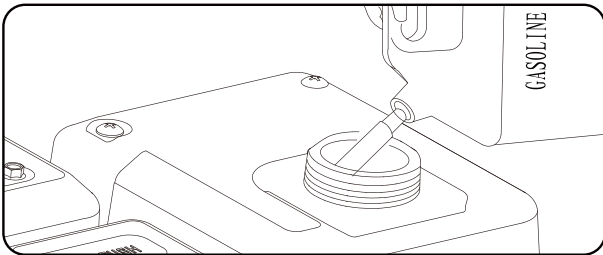

Pouring fuel too fast through the fuel screen may result in blow back of fuel at the operator while filling.

Use regular unleaded gasoline with a minimum octane rating of 87.

- Do not mix oil and gasoline.
- Add fuel until reach the red line.
- DO NOT pump gas directly into the wood chipper at the gas station. Use an approved container to transfer the fuel to the wood chipper.
- DO NOT fill fuel tank indoors.
- DO NOT fill fuel tank when the engine is running or hot.
- DO NOT overfill the fuel tank.
- DO NOT light cigarettes or smoke when filling the fuel tank.



Our engines work well with 10% or less ethanol blend fuels. When using blended fuels there are some issues worth noting:

- Ethanol-gasoline blends can absorb more water than gasoline alone.
- These blends can eventually separate, leaving water or a watery goo in the tank, fuel valve and carburetor.
- With gravity-fed fuel supplies, this compromised fuel can be drawn into the carburetor and cause damage to the engine and/or potential hazards.
- There are only a few suppliers of fuel stabilizer that are formulated to work with ethanol blend fuels.
- Any damages or hazards caused by using improper fuel, improperly stored fuel, and/or improperly formulated stabilizers, are not covered by manufacturer's warranty.



It is advisable to always shut off the fuel supply, run the engine to fuel starvation and drain the tank when the equipment is not in use for more than 30 days.

Starting Engine

1. Move the engine switch to the ON position.
2. Open the fuel shut-off valve.
3. Move the choke lever to the START position.

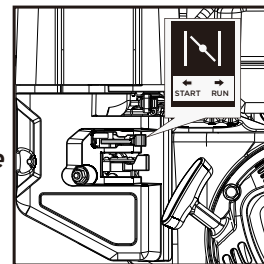
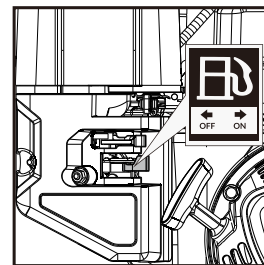
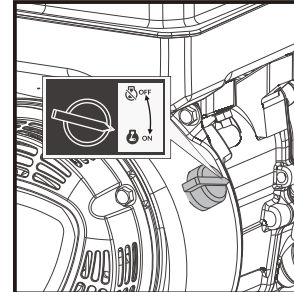

If the engine is hot, >> no need to flip the choke lever onto START.

4. Pull the recoil starter until engine compression has become difficult to pull. Let the recoil return to the home position, then pull quickly to start the engine. Repeat steps as needed.
5. Fully open the choke.



Rapid retraction of the starter cord (kickback) will pull your hand and arm toward the engine faster than you can let go. Broken bones, fractures, bruises, or sprains could result.

Operating

Starting the engine and letting it idle for one minute.

This chipper can process tree limbs, branches, and organic matter (such as corn stalks). Tree branches must be inserted with the large, cut end first into the Chipper Chute Opening. As the unit chips the load, there will be some occasional debris kickback. Always stand away from the unit and allow the self-feeding action pull the load to the cutting disc.

The chipper shredder is designed to break down and shred light brush, leaves, and soft but bulky organic waste. Load this type of material (no larger than 0.5inch in diameter) into the top of the Feed Hopper. The material is then pulled into the cutting chamber by airflow

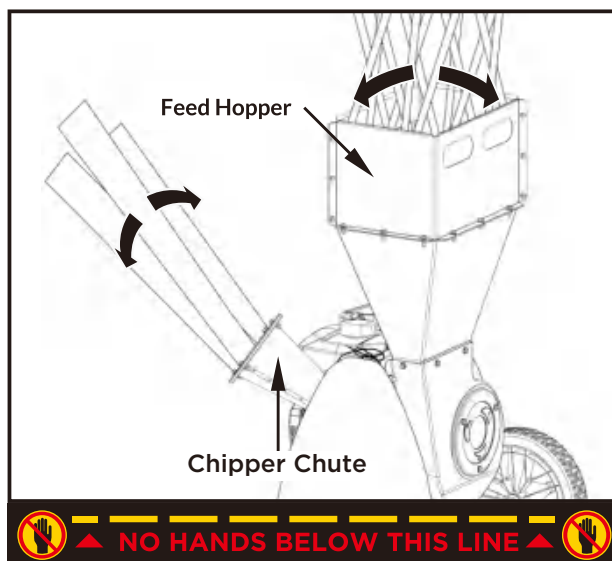

Feed tree limbs or branches with the cut end first into the hopper opening, leaving the brushy head to be chipped last. This helps guide the limb down the feed hopper opening and reduces the chance of cut pieces being tossed back up the hopper opening. Some branches may be required to be pre-cut to provide a more efficient self-feeding action.

While operating the machine, keep a wooden stick handy, approximately 1 inch in diameter by 2 feet long. This stick will be useful to push in short, brushy and very leafy materials and keep the feed hopper clear.

Do not force material into the machine. If it does not chip well, the chipper knives may need sharpening or to be replaced.

Do not overload the machine by filling the hopper opening with too much material at one time. **As a load passes through the cutting disc and is discharged, the engine speed may decrease. Allow enough time for the engine to accelerate to the highest RPM before another load is added.** In the event of overload condition, stop feeding material into the hopper.

The chipper can clog up with soft, wet, or fibrous materials. However, if you feed soft materials intermittently with branches, there should be no problem, as the chipper tends to clean out any residue left in the machine.

If any stringy material wraps around the rotor shaft, remove it before it works its way into the bearing.

If the chipper stalls from overloading or clogging, turn off the engine's power switch and wait until the cutting disk is completely stopped. Allow the engine to completely cool and switch the engine to off. Open the housing cover to clear and remove all the materials from the housing. Lock the housing cover, switch the engine to the on position, and start the machine again to resume operation.

As the discharge material piles up, move the chipper away from the pile. This will keep the material from backing up the discharge chute. Do not position the deflector vertically, as this will reduce the airflow, impeding the discharge and causing blockage.



Make sure the machine is level and stable to avoid unnecessary vibrations.



Do not operate on concrete or other hard surface.



Do not open the housing cover unless the engine and cutting disk are completely stopped and the belt drive is disengaged.



To shut down the machine, turn the engine switch to the OFF position, and it will gradually come to a standstill.

Stop Engine

To stop the engine in an emergency, simply turn the engine switch to the OFF position. Under normal conditions, use the following procedure:

1. Let the engine idle for one or two minutes.
2. Turn the engine switch to the OFF position.
3. Turn the fuel valve lever to the OFF (OFF) position.



Do not move the choke control to CHOKE to stop the engine. Backfire or engine damage may occur.

Wait until the machine completely stops. Allow the engine to completely cool. **Remove the engine's spark plug.** Then clean out the interior of the machine and its discharge chute.

TRANSPORTING

Your chipper is equipped with two large wheels for easy movement by hand. To move the unit, grip the handles and tilt the chipper slightly after making sure the oil tank cover is tightened.

MAINTENANCE

Maintaining your chipper will ensure long life to the machine and its components.

Preventive Maintenance

1. Turn off the engine. The engine must be cool.
2. Keep the engine's throttle lever in its SLOW position and remove the spark plug wire from the spark plug and secure.
3. Inspect the general condition of the chipper. Check for loose screws, misalignment or binding of moving parts, cracked or broken parts, and any other condition that may affect its safe operation.
4. Remove all debris from the chipper with a soft brush, vacuum, or compressed air. Then use a premium quality lightweight machine oil to lubricate all moving parts.
5. Place the spark plug wire back.



Never use a pressure washer to clean your chipper. Water can penetrate tight areas of the unit and cause damage to spindles, pulleys, bearings, or the engine.



Shut down the engine, wait for all moving parts to come to a complete stop, remove the spark plug wire, and then wait five minutes before performing maintenance on the chipper.

Regular Maintenance Checklist

The service intervals shown are the maximum under normal operating conditions. Increase frequencies under extremely dirty or dusty conditions.

Procedure	Before each use	Every 8-10 Hours	Every 40 Hours
Check engine oil level	▲		
Check general equipment condition	▲		
Check that cutting disk turns freely (with a long stick only)	▲		
Visually inspect knife for damage	▲		
Check knife for sharpness		▲	
Check knife attachment screws		▲	
Check for any loose nut and bolts		▲	
Change engine oil	1 st time 5 hours		▲
Inspect or replace spark plug			▲
Inspect or replace air filter and precleaner			▲

Engine Maintenance

To prevent accidental starting, remove and ground spark plug wire before performing any service.

Changing the Engine Oil

Change oil when the engine is warm. Refer to the oil specification to select the proper grade for your operating environment.

1. Remove the oil drain plug with a 15 mm socket and extension. (Not included)
2. Allow the oil to drain completely.

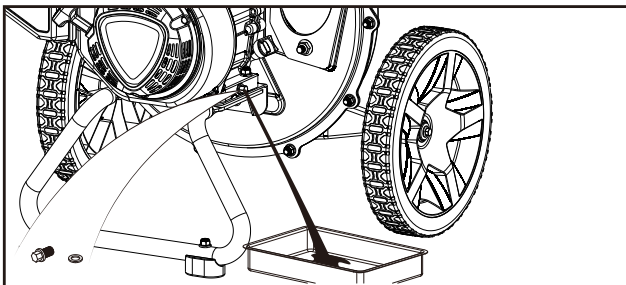

3. Replace the drain plug.
4. Remove oil fill cap/dipstick to add oil.
5. Add up to 20.3 fl. oz (600 ml) of oil and replace oil fill cap/dipstick. DO NOT OVERFILL.
6. Dispose of used oil at an approved waste management facility.

NOTICE

If using the dipstick to check oil level, DO NOT screw in the dipstick while checking.

WARNING

Used oil is a hazardous waste product and must be disposed of properly. Do not discard with household waste. Check with your local authorities, service center, or dealer for safe disposal/recycling facilities.

Cleaning and Adjusting the Spark Plug(s)

1. Remove the spark plug cable from the spark plug.
2. Use a spark plug socket (not included) to remove the plug.
3. Inspect the electrode on the plug. It must be clean and not worn to produce the spark required for ignition.
4. Make certain the spark plug gap is 0.7 - 0.8 mm (0.028 - 0.031 in.).

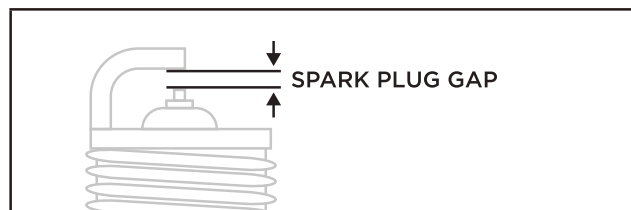

5. Refer to the spark plug section on the Specifications page when replacing the plug.
6. Carefully thread the plug into the engine.
7. Use a spark plug socket (not included) to firmly install the plug.
8. Attach the spark plug wire to the plug.

Clean the Air Filter

1. Remove the plastic outer casing.
2. Remove the foam element.
3. Wash in liquid detergent and water.
Squeeze thoroughly dry in a clean cloth.
4. Saturate in clean engine oil.
5. Squeeze in a clean, absorbent cloth to remove all excess oil.
6. Place the filter in the assembly.
7. Reattach the air filter cover.

Hammer Slice Check

Remove the rotor housing cover and cover plate. Check the triangle hammer slicer and J-type hammer slicer. If one or both are damaged, replacement is recommended.

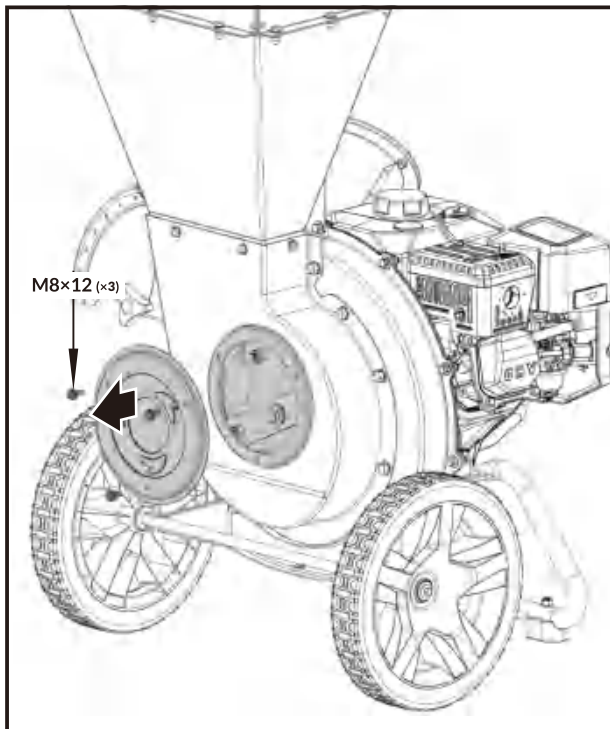

Knife Check

Remove the chipper chute from the unit and rotate the cutting disc to inspect the sharpness of the knives.

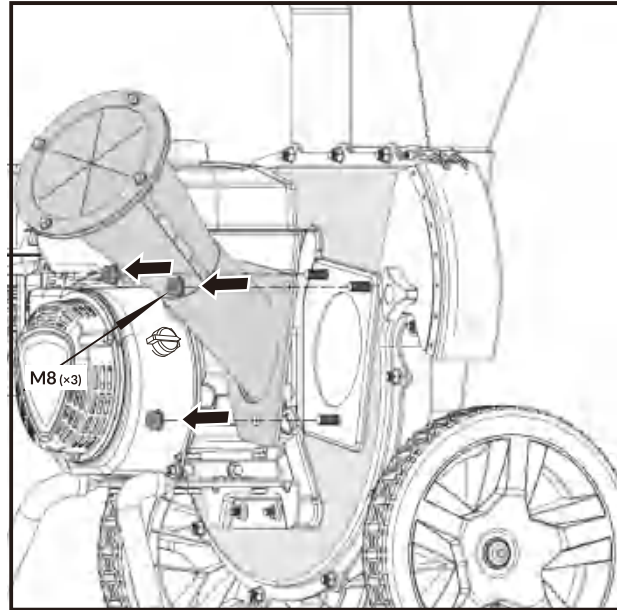

Knife Inspection

Checking the sharpness of the knives routinely will keep your chipper operating normally. Using dull knives will decrease performance and cause excessive vibration, which may damage the machine and make chipping difficult.

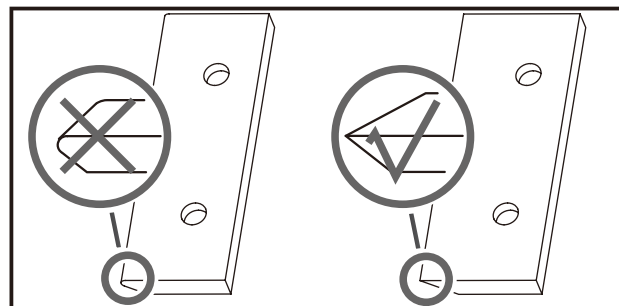

KNIFE REMOVAL AND REPLACEMENT

This chipper is equipped with two chipper knives that are mounted on the cutting disk. When the knives are dulling or show nicks, the machine will lose the self-feeding action. Material will have to be pushed in. Another indication that the knives will need to be inspected is the debris that is discharged will come out in long strips. Below are the instructions to replace the knives.

1. Remove the deflector bracket.

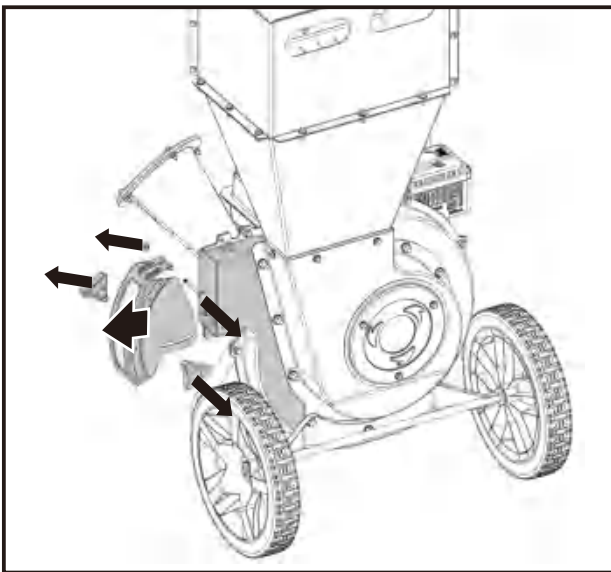

2. Remove the M8×16 bolts and nuts that connect the rotor housing and rotor disc seat.
3. Put one support block under engine.
4. Detach the rotor housing and hopper from the rotor disc seat.

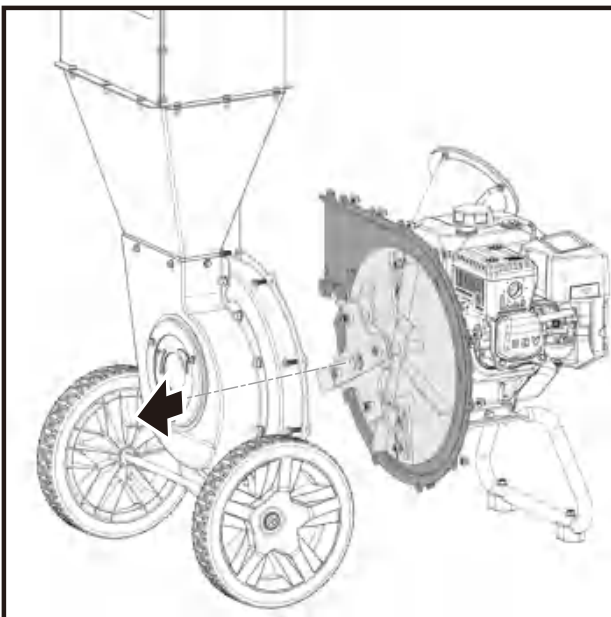

5. Using Allen key S4 to remove the two screws on top of engine shaft bushing.
6. Using Wrench S13 to remove the screw fixing the engine shaft.

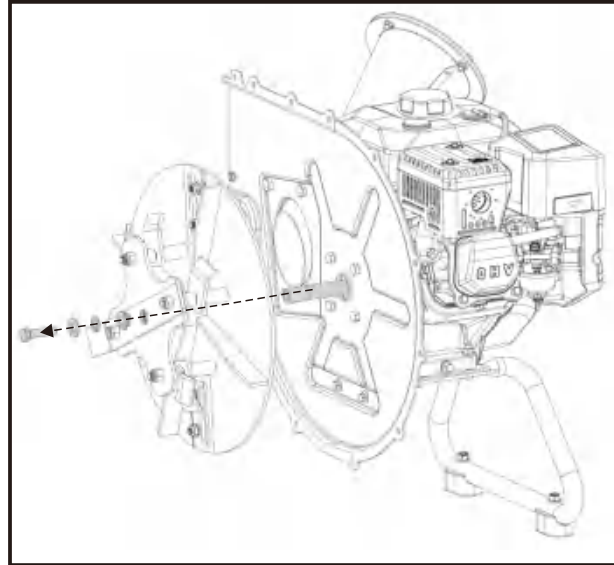

7. If the hammer slicers are damaged, remove the four M12×55 bolts that hold the J-type hammer slicer and triangle hammer slicer, and replace.

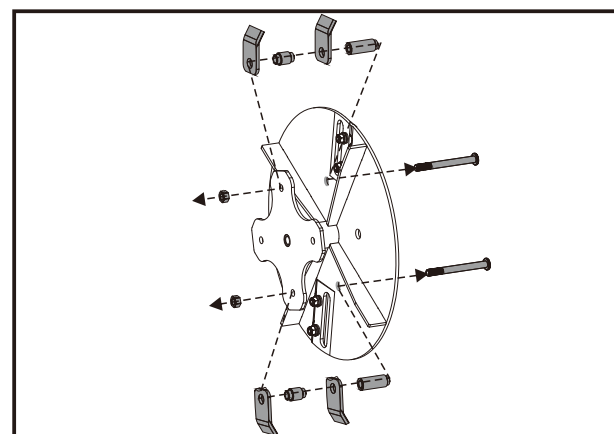
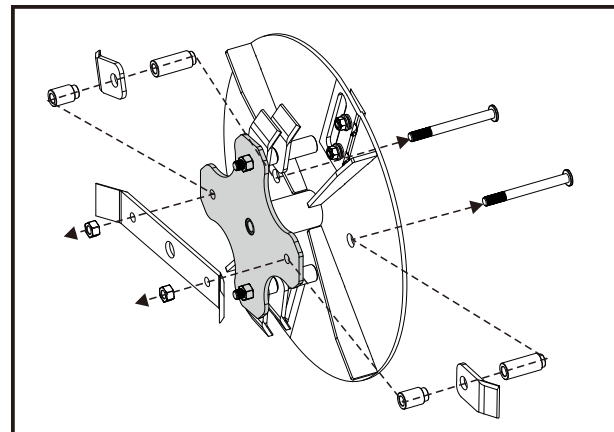

8. If the knife shows signs of wear, replace it. Using the 8mm hex wrench, reach into the main housing and remove the two socket head cap screws and the chipper knife.

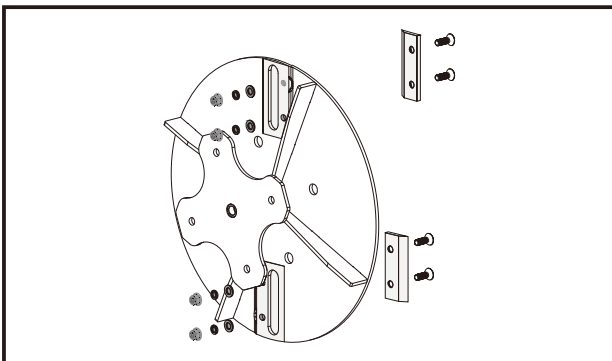

Be careful and wear gloves when working near the knives.



If the cutting disk surface is not cleaned properly and the knives are not mounted flush on the cutting disk, the knives could crack when the hardware is tightened.



When install back the screws/bolts in step 5, 6, 7, 8 apply thread glue on the bolts/screws first.

Knife Resharpener

After removal, the knives should be sharpened on a surface grinder. Be careful and wear gloves to protect your hands. It is extremely important to consistently maintain the 38-degree cutting angle for proper performance.

Make sure there is plenty of coolants used during the grinding process, since excessive heat damages the knives and weakens the metal. If you are unable to sharpen the knives yourself, take them to a professional machine shop for proper sharpening. Normally only as light touch-up is needed.

Engine Oil / Fuel

Refer to the engine manual packed separately with your unit for information on how to check or add oil/fuel and for recommendations.

Engine Maintenance

Refer to the engine manual packed separately with your unit for detailed information and a maintenance schedule.

STORAGE

GB

If your chipper will not be used for more than 30 days, follow the steps below to prepare your unit for storage :

1. Drain the fuel tank completely. Stale fuel has high gum content and can clog the carburetor and restrict fuel flow.
2. Start the engine and allow it to run until it stops. This ensures no fuel is left in the carburetor and helps prevent deposits from forming inside, which can damage the engine.
3. Drain the oil from the engine while it is still warm. Refill with fresh oil of the grade recommended in the engine manual.
4. Allow the engine to cool. Remove the spark plug and put 60 ml of SAE-30 high-quality engine oil into the cylinder. Pull the starter rope slowly to distribute the oil. Replace the spark plug.



Remove the spark plug and drain all oil from the cylinder before attempting to start the unit after storage.

5. Use clean cloths to clean off the outside of the chipper and to keep the air vents free from obstructions.



Do not use strong detergents or petroleum based cleaners when cleaning plastic parts. Chemicals can damage plastics.

6. Store your chipper in an upright position in a clean, dry building with good ventilation.



Do not store your chipper with fuel in a non-ventilated area where fuel fumes could reach flames, sparks, pilot lights or any ignition sources. Use only approved fuel containers.

TROUBLE SHOOTING

Problem	Cause	Remedy
Engine fails to start	<ol style="list-style-type: none"> 1. Spark plug wire is disconnected 2. Out of fuel or stale fuel 3. Engine and/or Fuel valve is not in ON position 4. Choke lever is not in CLOSE position 5. Blocked fuel line 6. Fouled spark plug 7. Engine flooding 8. No oil in engine 	<ol style="list-style-type: none"> 1. Attach spark plug wire securely to spark plug 2. Fill with clean, fresh gasoline 3. Engine and Fuel valve must be in ON position 4. Choke level must be in CLOSE position for a cold start 5. Clean fuel line 6. Clean, adjust gap, or replace 7. Wait a few minutes to restart, but do not prime 8. Add engine oil to engine
Engine runs erratically	<ol style="list-style-type: none"> 1. Spark plug wire is loose 2. Unit running with Choke lever in CLOSE position 3. Blocked fuel line or stale fuel 4. Vent plugged 5. Water or dirt in fuel system 6. Dirty air cleaner 	<ol style="list-style-type: none"> 1. Connect and tighten spark plug wire 2. Move choke lever to OPEN position 3. Clean fuel line. Fill tank with clean, fresh gasoline 4. Clear vent 5. Drain fuel tank. Refill with fresh fuel 6. Clean or replace air cleaner
Engine overheats	<ol style="list-style-type: none"> 1. Engine oil level low 2. Dirty air cleaner 3. Air flow restricted 	<ol style="list-style-type: none"> 1. Fill crankcase with proper oil 2. Clean air cleaner 3. Remove housing and clean
Chipping action seems too slow, cutting disk stalls, or no material is discharged when engine is running	<ol style="list-style-type: none"> 1. Engine speed is too slow causing belt to slip 2. Knives are dull or damaged 3. Cutting disk is jammed by debris from the feed hopper and discharge chute 4. Discharge chute is clogged 	<ol style="list-style-type: none"> 1. Run the engine at full throttle 2. Sharpen or replace knives 3. Remove any built-up debris and turn cutting disk with a wooden stick to be sure it turns freely 4. Clean out debris
When chipping, branch seems to vibrate and move about excessively with unusual noise	<ol style="list-style-type: none"> 1. Knives are dull or damaged 2. Knives are not properly seated on the cutting disk 3. Rotor is overloaded with material 	<ol style="list-style-type: none"> 1. Sharpen or replace knives 2. Loosen the knife mounting screws, reset the knives and tighten the screws 3. Allow unit to clear itself before adding more material to the hopper

PARTS SCHEDULE

GB

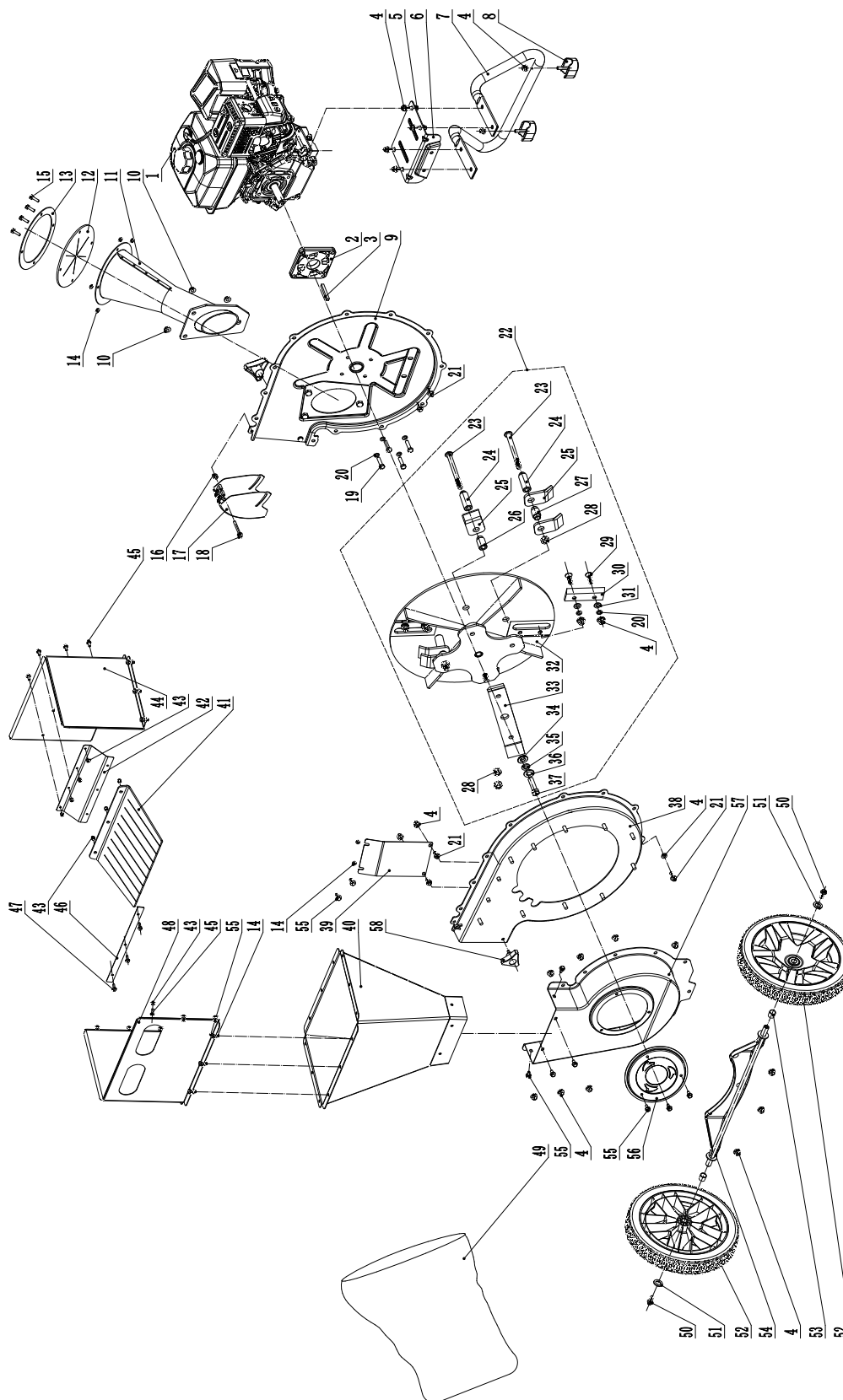

#	Part Number	Description	Qty
1	TRA-0401	Engine, 224cc	1
2	602.300601.01	Junction Plate Assembly, Engine	1
3	2.14.002	Flat Key, 6.3 x 6.3 x 50	1
4	1.6187.1.08	Lock Nut, M8	32
5	1.5789.0840	Flange Bolt, M8 x 40	4
6	602.300901.00.2	Support Mount Assembly, Black	1
7	602.300011.01.2	Tube Support, Black	1
8	602.300021.00.2	Rubber Cushion, Black	2
9	602.300200.03.2	Inner Flail Housing Assembly, Black	1
10	1.6187.1.10	Lock Nut, M10x1.5	3
11	602.300110.02.34	Lower Chipper Chute Assembly, Blue	1
12	602.300103.02	Block Rubber, Black	1
13	602.300112.02.34	Pressure Plate, Rubber Block, Blue	1
14	1.6187.1.06	Lock Nut, M6	18
15	1.5789.0620	Flange Bolt, M6 x 20	4
16	1.6182.06	Lock Nut, M6	1
17	602.300401.01.2	Chute Deflector Assembly, Black	1
18	2.08.177	Flange Bolt, M6 x 55	1
19	2.08.137	Bolt , 5/16 - 24UNF	4
20	1.93.08	Lock Washer, Ø8	8
21	1.16674.0820	Bolt, M8 x 20	14
22	602.303000.00	Impeller Assembly	1
23	602.303005.00	Clevis Pin	4
24	602.303006.02	Bush $\phi 18.5 \times \phi 10.5 \times 43.5$	4
25	602.303004.01	Flail Blade	6
26	602.303006.01	Bush $\phi 18.5 \times \phi 10.5 \times 24.5$	2
27	602.303006.00	Bush $\phi 18.5 \times \phi 10.5 \times 19.5$	2
28	1.6182.10	Lock Nut, M10	4
29	1.70.3.0825	Machine Screw, M8 x 25	4
30	601.303002.00	Chipper Blade	2

#	Part Number	Description	Qty
31	1.848.08	Washer, Ø8	4
32	602.303100.00.2	Impeller Assembly, Black	1
33	602.303004.00	Shredder Blade	1
34	602.300024.00	Washer	1
35	2.03.063	Lock Washer, Ø12	1
36	2.03.062	Washer, Ø12	1
37	2.08.136	Screw, 7/16 - 20UNF	1
38	602.300500.03.2	Outer Flail Housing Assembly, Black	1
39	602.301751.03.2	Hopper Support Bracket, Black	1
40	602.301700.03.34	Feed Hopper Assembly, Blue	1
41	602.301721.00	Baffle, Black	1
42	602.301721.03.34	Baffle, Blue	1
43	1.6182.05	Lock Nut, M5	13
44	602.301709.03.34	Booster Baffle Left, Blue	1
45	1.5789.0512	Bolt, M5 x 12	10
46	602.301722.00.34	Rubber Baffle Press Plate, Blue	1
47	1.16674.0516	Bolt, M5 x 16	3
48	602.301709.04.34	Booster Baffle Right, Blue	1
49	1.97.1.05	Washer, Ø5	10
50	9.1400.005	Collection Bag	1
51	1.5789.0612	Flange Bolt, M6 x 12	4
52	1.16674.0812	Bolt, M8 x 12	2
53	2.03.067	Washer, Ø15	2
54	254.201701.06.2	12 in.Wheel, Black	2
55	602.301744.00	Jacket Axle, Black	2
56	602.301740.00.2	Axle Assembly, Black	1
57	1.5789.0615	Flange Bolt, M6 x 15	17
58	602.300800.01.34	Maintenance Cover, Blue	1
59	602.300701.00.2	Inlet Guide, Black	1
60	602.300020.00.2	Knob, M6	2

ENGINE PARTS SCHEDULE

GB

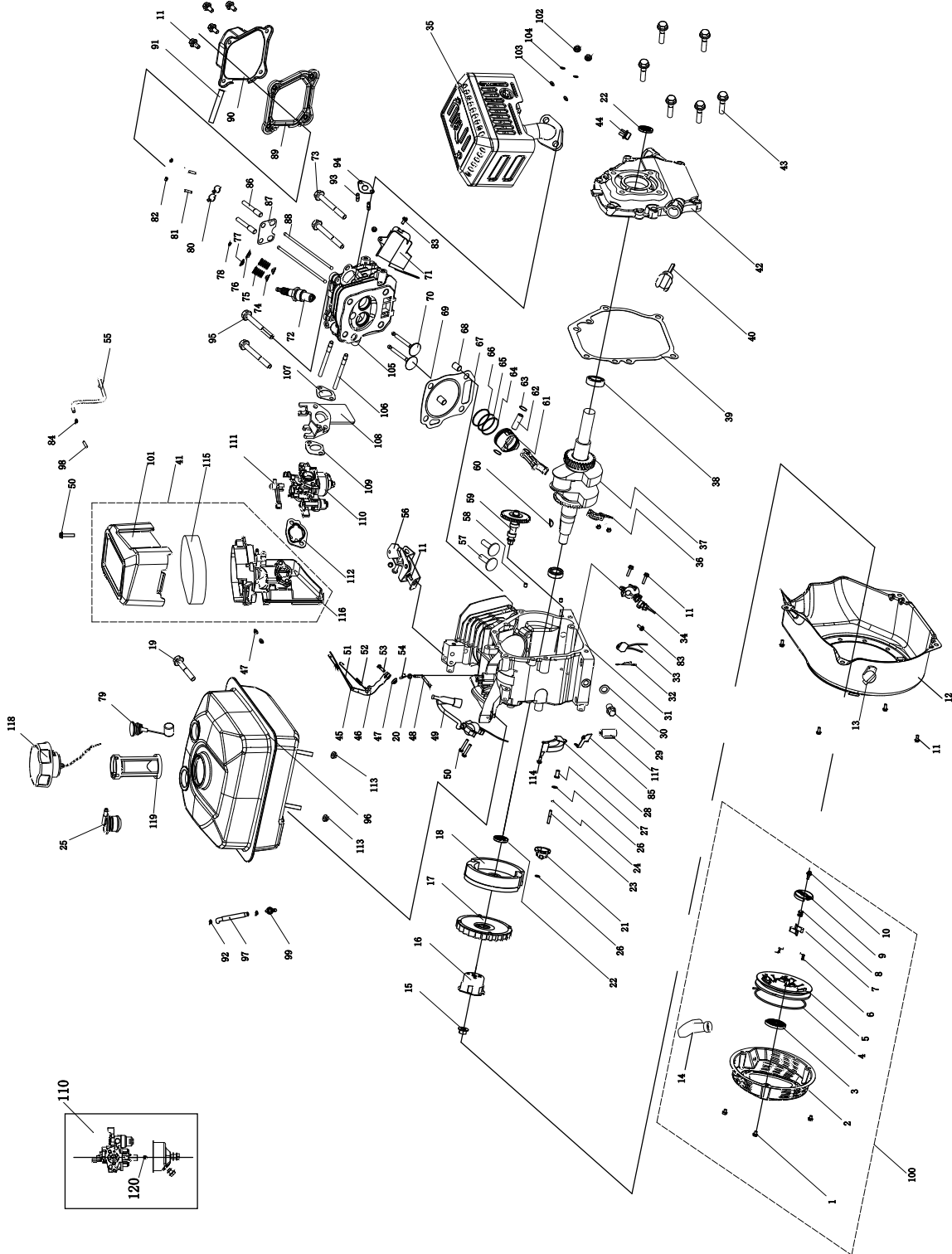

Engine Parts List

#	Part Number	Description	Qty
1	1.16674.0608	Flange Bolt M6 x 8	3
2	27.061100.04.2	Cover, Recoil Starter, Black	1
3	21.061005.00	Spring, Recoil Starte	1
4	2.10.003.1	Rope Ø4 x 1550, Black	1
5	21.061001.01	Reel, Recoil Starter	1
6	45.060003.00	Spring, Ratchet	2
7	45.060002.00	Starter Ratchet, Steel	2
8	45.060009.00	Spring, Ratchet Guide	1
9	45.060007.00	Ratchet Guide	1
10	45.060008.00	Screw, Ratchet Guide	1
11	1.5789.0612	Flange Bolt M6 x 12	12
12	27.080100.11.34	Fan cover, Blue	1
13	21.120200.00	Switch	1
14	21.061300.00	Handle, Recoil	1
15	2.02.006	Nut M14	1
16	23.060001.01	Pulley, Start	1
17	27.080001.00	Cooling Fan	1
18	24.120100.02	Flywheel	1
19	2.08.156	Flange Bolt Assembly M6 x 33	1
20	2.03.021.1	Washer Ø6.4 x Ø13 x 1	1
21	21.110100.00	Gear, Governor	1
22	2.11.001	Oil Seal Ø25 x Ø41.3 x 6	2
23	21.110013.00	Shaft, Governor Gear	1
24	21.110011.00	Clip, Governor Gear	1
25	152.070800.00	Reversal Valve	1
26	2.03.020.1	Washer Ø6.2 x Ø15 x 0.5	2
27	21.110012.01	Bushing, Governor Gear	1
28	23.080600.00	Air Guide, Right	1
29	2.08.037	Drain Bolt M10 x 1.25 x 25	2
30	2.03.016	Washer Ø10 x Ø16 x 1.5, Drain Bolt	2
31	27.030100.06	Crankcase	1
32	23.120700.00	Change Wire Flameout	1
33	21.120400.00	Diode Assembly	1
34	21.127000.02	Oil Level Sensor	1
35	27.101000.17.2	Muffler Assembly, Black	1
36	27.050200.00	Connecting Rod	1
37	27.050100.03	Crankshaft	1
38	1.276.6205	Bearing 6205	2
39	24.030008.00	Gasket, Crankcase Cover	1
40	21.031000.00.34	Oil Dipstick Assembly, Blue	1

#	Part Number	Description	Qty
41	27.091000.09	Air Cleaner Assembly	1
42	24.030007.00	Cover, Crankcase	1
43	1.5789.0832	Flange Bolt M8 x 32	6
44	21.031000.01.1	Oil Filler Cap, Black	1
45	23.110005.01	Spring, Throttle Return	1
46	27.110003.00	Arm, Governor	1
47	1.6177.06	Nut M6	3
48	21.110001.00	Shaft, Governor Arm	1
49	22.123000.02	Ignition Coil	1
50	1.5789.0625	Flange Bolt M6 x 25	3
51	23.110006.00	Rod, Governor	1
52	23.110007.00	Spring, Governor	1
53	2.08.040	Bolt M6 x 21, Governor Arm	1
54	21.110008.00	Pin, Shaft	1
55	24.070014.06	Pipe, Reversal Valve	1
56	27.111000.00	Control Assembly	1
57	25.040013.00	Lifter, Valve	2
58	2.04.001	Dowel Pin Ø9 x 14	2
59	27.041000.03	Camshaft	1
60	2.14.012	Woodruff Key 4 x 7.5 x 19	1
61	27.050005.00	Piston	1
62	23.050003.00	Pin, Piston	1
63	2.09.001	Circlip Ø18 x Ø1	2
64	27.050303.00	Ring, Oil	1
65	27.050302.00	Ring, Second Piston	1
66	27.050301.00	Ring, First Piston	1
67	27.030009.01	Gasket, Cylinder Head	1
68	2.04.003	Dowel Pin Ø10 x 14	2
69	23.040002.02	Valve, Intake	1
70	23.040006.02	Valve, Exhaust	1
71	25.080400.00	Air Guide, Lower	1
72	2.15.002	Spark Plug F6RTC	1
73	1.5789.0865	Flange Bolt M8 x 65	3
74	23.040017.00	Valve Oil seal	2
75	21.040003.00	Oil Seal, Valve	2
76	21.040007.00	Retainer, Exhaust Valve Spring	1
77	21.040001.00	Retainer, Intake Valve Spring	1
78	21.040008.00	Rotator, Exhaust Valve	1
79	27.072000.01	Fuel Gauge Assembly	1
80	21.040009.00	Rocker Arm	2

Engine Parts List

GB

#	Part Number	Description	Qty
81	21.040020.00	Screw, Valve Adjustment	2
82	21.040021.00	Nut M6, Lock	2
83	1.5789.0608	Flange Bolt M6 x 8	3
84	2.06.006	Clamp Ø7 x Ø1	1
85	21.080002.00	Suppoet, Diode	1
86	21.040010.00	Bolt, Rocker Arm	2
87	23.040004.00	Guide Plate, Push Rod	1
88	27.040005.00	Push Rod	2
89	21.020002.00	Gasket, Cylinder Head Cover	1
90	21.021000.00	Cover, Cylinder Head	1
91	21.020001.00	Breather Tube	1
92	2.06.005	Clamp Ø9 x Ø1	2
93	2.01.010	Stud Bolt M8 x 35	2
94	26.100001.00	Gasket, Exhaust Pipe	1
95	2.08.121	Flange Bolt M10 x 65	1
96	27.071000.05.2	Fuel Tank	1
97	24.070011.03	Pipe	1
98	24.070030.00	Venthole	1
99	21.070600.03	Joint, Fuel Pipe	1
100	27.061000.04	Recoil Assembly	1
101	27.091200.09	Cover, Air Cleaner	1

#	Part Number	Description	Qty
102	1.6175.08	Nut M8	2
103	1.848.08	Washer Ø8	2
104	1.93.08	Lock Washer Ø8	2
105	26.010100.01	Cylinder Head, 224cc	1
106	2.01.009	Stud Bolt M6 x 110	2
107	24.130002.00	Gasket, Insulator	1
108	23.130001.00	Insulator, Carburetor	1
109	22.130003.00	Gasket, Carburetor	1
110	27.131000.20	Carburetor	1
111	27.130100.00	Choke Handle	1
112	21.130004.00	Gasket, Air Cleaner	1
113	1.6187.106	Nut M6	2
114	1.5789.0620	Flange Bolt M6 x 20	1
115	27.091003.05	Element, Air Cleaner	1
116	27.091100.05	Base, Air Cleaner	1
117	27.210003.00	Wire Sheath	1
118	24.070100.02	Cap, Fuel Tank	1
119	46.070300.00	Fuel Filter, Fuel Tank	1
120	27.131017.20	Main Jet, Standard	1
	27.131017.20.01	Main Jet, Altitude	/

PLEASE READ THE FOLLOWING CAREFULLY

THE MANUFACTURER AND/OR DISTRIBUTOR HAS PROVIDED THE PARTS LIST AND ASSEMBLY DIAGRAM IN THIS DOCUMENT AS A REFERENCE TOOL ONLY. NEITHER THE MANUFACTURER OR DISTRIBUTOR MAKES ANY REPRESENTATION OR WARRANTY OF ANY KIND TO THE BUYER THAT HE OR SHE IS QUALIFIED TO MAKE ANY REPAIRS TO THE PRODUCT, OR THAT HE OR SHE IS QUALIFIED TO REPLACE ANY PARTS OF THE PRODUCT. IN FACT, THE MANUFACTURER AND/OR DISTRIBUTOR EXPRESSLY STATES THAT ALL REPAIRS AND PARTS REPLACEMENTS SHOULD BE UNDERTAKEN BY CERTIFIED AND LICENSED TECHNICIANS, AND NOT BY THE BUYER. THE BUYER ASSUMES ALL RISK AND LIABILITY ARISING OUT OF HIS OR HER REPAIRS TO THE ORIGINAL PRODUCT OR REPLACEMENT PARTS THERETO, OR ARISING OUT OF HIS OR HER INSTALLATION OF REPLACEMENT PARTS THERETO.

Limited 30 Day Warranty

Our company makes every effort to assure that its products meet high quality and durability standards, and warrants to the original purchaser that this product is free from defects in materials and workmanship for the period of 30 days from the date of purchase. This warranty does not apply to damage due directly or indirectly, to misuse, abuse, negligence or accidents, repairs or alterations outside our facilities, criminal activity, improper installation, normal wear and tear, or to lack of maintenance. We shall in no event be liable for death, injuries to persons or property, or for incidental, contingent, special or consequential damages arising from the use of our product. Some states do not allow the exclusion or limitation of incidental or consequential damages, so the above limitation of exclusion may not apply to you. THIS WARRANTY IS EXPRESSLY IN LIEU OF ALL OTHER WARRANTIES, EXPRESS OR IMPLIED, INCLUDING THE WARRANTIES OF MERCHANTABILITY AND FITNESS.

To take advantage of this warranty, the product or part must be returned to us with transportation charges prepaid. Proof of purchase date and an explanation of the complaint must accompany the merchandise. If our inspection verifies the defect, we will either repair or replace the product at our election or we may elect to refund the purchase price if we cannot readily and quickly provide you with a replacement. We will return repaired products at our expense, but if we determine there is no defect, or that the defect resulted from causes not within the scope of our warranty, then you must bear the cost of returning the product.

This warranty gives you specific legal rights and you may also have other rights which vary from state to state.

**Combined Exhaust and Evaporative Emissions Control
Warranty Statement**

GB

YOUR WARRANTY RIGHTS AND OBLIGATIONS

The United States Environmental Protection Agency and DU DU GROUP (DU DU) are pleased to explain the emission control system warranty on your 2024 model year small off-road engine/equipment. In the United States, new small off-road engine/equipments must be designed, built and equipped to meet stringent anti smog standard. DUDU must warrant the emission control system on your small off-road engine/equipment for the periods of time listed below provided there has been no abuse, neglect or improper maintenance of your small off-road engine/equipment.

Where a warrantable condition exists, DUDU will repair your small off-road engine/equipment at no cost to you, including diagnosis, parts and labor.

MANUFACTURER'S WARRANTY COVERAGE:

This emissions control system is warranted for two years. If any emission-related part on your small off-road engine/equipment is defective, the part will be repaired or replaced by DU DU.

OWNER'S WARRANTY RESPONSIBILITIES:

As the small off-road engine/equipment owner, you are responsible for the performance of the required maintenance listed in your owner's manual. DUDU recommends that you retain all receipts covering maintenance on your small off-road engine/equipment, but DUDU cannot deny warranty solely for the lack of receipts or for your failure to ensure the performance of all scheduled maintenance.

As the small off-road engine/equipment owner, you should however be aware that DU DU may deny you warranty coverage if your small off-road engine/equipment or a part has failed due to abuse, neglect, improper maintenance or unapproved modifications.

If you have any questions regarding your warranty rights and responsibilities, you should contact DU DU GROUP at (888)680-2849 or inquiry@bilthardusa.com.

DEFECTS WARRANTY REQUIREMENTS:

(a) The warranty period begins on the date the engine/equipment is delivered to an ultimate purchaser.

(b) General Emissions Warranty Coverage. DUDU warrants to the ultimate purchaser and each subsequent owner that the engine/equipment is:

(1) Designed, built, and equipped so as to conform with all applicable regulations adopted by the Environmental Protection Agency.

(2) Free from defects in materials and workmanship that causes the failure of a warranted part for a period of two years.

(c) Warranty Parts for Exhaust Emission.

- (1) Fuel System
- (2) Air Induction System
- (3) Ignition System

The following parts are also considered emission related components for exhaust emissions, if applicable:

- (1) Exhaust Gas Recirculation (EGR) System
- (2) After treatment devices.
- (3) Crankcase ventilation valves.
- (4) Sensors.
- (5) Electronic control units.

(d) Warranty Parts for Evaporative Emission include fuel tank, fuel cap, fuel line and fittings, carbon canister, vapor hoses. They may also include, if applicable, liquid/vapor separator, clamps, pressure relief valves, etc.

Du Du will furnish with each new engine/equipment written instructions

for the maintenance and use of the engine/equipment by the owner.

GB

PLEASE READ THE FOLLOWING CAREFULLY

The manufacturer and/or distributor has provided the parts list and assembly diagram in this manual as a reference tool ONLY. Neither the manufacturer or distributor makes any representation or warranty of any kind to the buyer that he or she is qualified to make any repairs to the product, or that he or she is qualified to replace any parts of the product. In fact, the manufacturer and/or distributor expressly states that all repairs and parts replacements should be undertaken by certified and licensed technicians, and not by the buyer. The buyer assumes all risk and liability arising out of his or her repairs to the original product or replacement parts thereto, or arising out of his or her installation of replacements thereto.

