

This flow chart is applicable to PulseTech Grid and Reels systems properly installed in an indoor location.

This troubleshooting guide does not take the place of any safety procedures.

When troubleshooting a PulseTech Grid and Reel systems the technician will need to have some sort of lift system to ensure fall hazards are adequately addressed. Prior to conducting any of the “off the ground” steps the technician must ensure they have adequate gear meeting the safety requirements for working in a fall hazard / off the ground environment. Proper precautions for lift or fall hazards, lift devices and proper safety steps for securing personnel during troubleshooting will not be addressed in this flow chart. Refer to your specific safety guidelines and OSHA recommendations before conducting any off the ground, fall hazard work.

---

**Table of Contents:** There is no way to cover every scenario that may be encountered in the field. If you are unsure how to proceed or just need some clarification contact your supporting FSR.

<b><u>Page</u></b>	<b><u>Description</u></b>
2.	Grid and Drop Reel Familiarization
3.	Drop Reel Familiarization
4.	No Lights displayed on a Drop Reel (one or more, but not whole zone out)
8.	No Lights on one or all zones

Our Troubleshooting guide will start at the power supply (grey box plugged into AC power) and work it's way up through the grid zones. Please contact your supporting FSR with any additional questions.

Throughout this TS guide we will refer to checking the items contained in the Grid & Drop Down Reel system.

Please take a minute to do some basic familiarization on what items are contained in this system and where / how you will run across them.

It all starts with power at the bottom and works its way up.

- AC input power to the Power Supply. This converts the AC to a DC output.
- DC output up from the Power Supply to the Junction Box.
- From the Junction Box we will have 3 sets of wires going out to the 3 zones of each grid system.
- Above each Drop Reel the Drop Reel harness is spliced into the zone power wires.
- The Drop Reels are usually hung on chains from the building crossbeams.
- The Drop Reel is connected via quick disconnect to the Drop Reel wire harness.

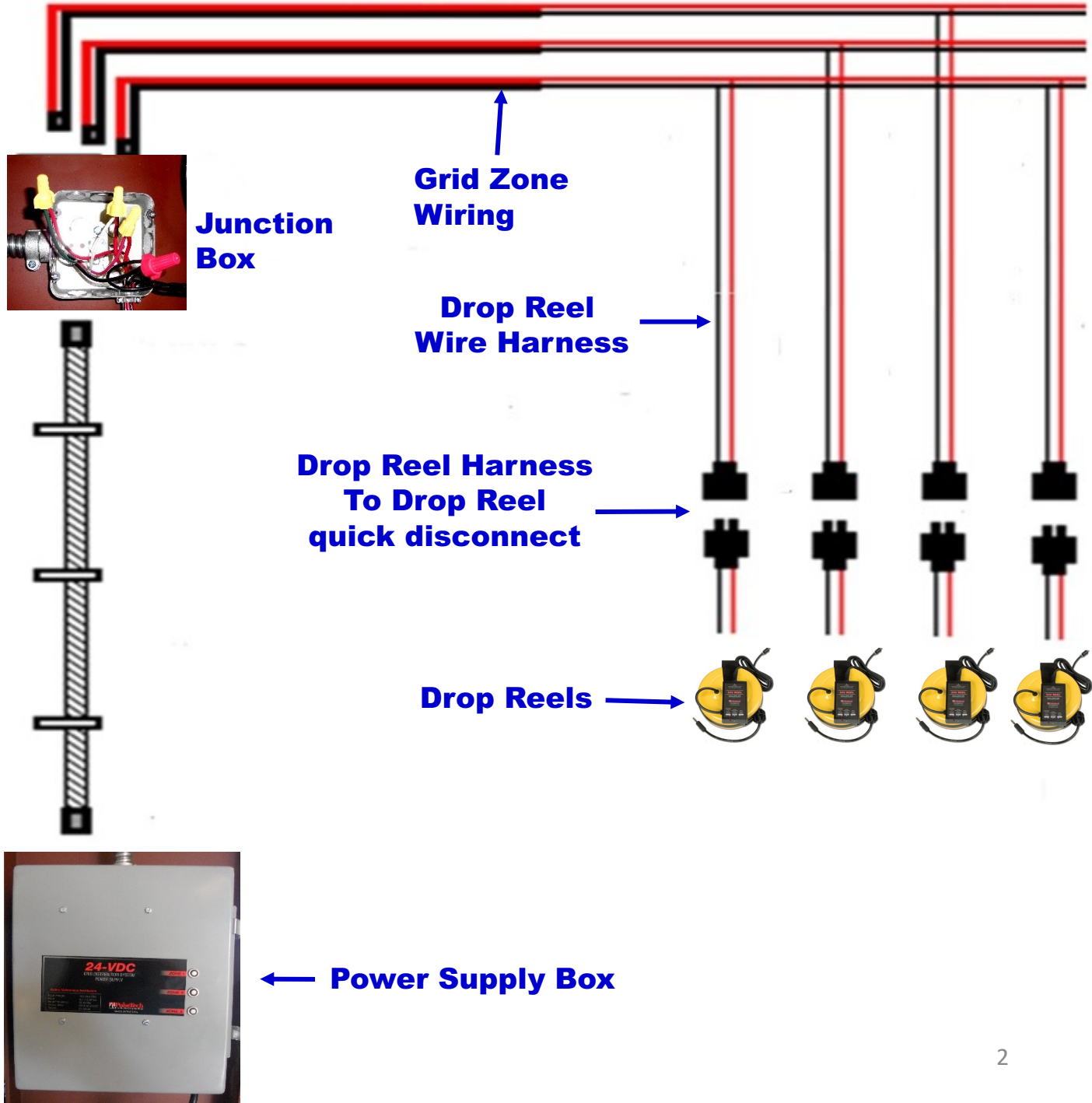

# No Lights displayed on a Drop Reel (one or more, but not whole zone out)

Throughout this TS guide we will refer to checking the lights on the Drop Reel. Below is an example of what we are referring to. Please take a minute to familiarize yourself with the LEDs that are displayed on the bottom of the Drop Reel.

## 24V REEL, 24-Volt Battery Charger Maintainer with Reel



The 24V Reel charging system monitors each battery. When a battery is fully charged, it shuts off the charge current but continues to pulse the battery to remove sulfation crystals. Colored LEDs indicate battery state-of-charge allowing for touch free operation.

**Red Monitor LED:** check the battery connection or the battery voltage is less than 22-Volts

**RED Pulse LED:** Pulse Technology is continually 'Pulsed'/applied to the battery in order to remove sulfation crystals off the battery plates.

**Solid Green Charge LED:** System is fully charged  
**Flashing Green Charge LED:** System is charging

Note: If no LED lights are illuminated, the Reel is not plugged into the Grid.



**PulseTech™**  
800-580-7554 ext.2  
www.pulsetech.com 998XM003

Go to next page.

# No Lights displayed on a Drop Reel (one or more, but not whole zone out)

If you have one or more Drop Reels that are not displaying any lights please take the following steps:



Unplug the grid power supply for 15 seconds and reconnect.

Are all zone Reel Drops now illuminated?

NO

YES

Attempt to flash the system. Unplug AC power and reconnect. Do this 3 times waiting 5 seconds in between attempts.

Are all zone Reel Drops now illuminated?

NO

YES



Reel Drop – Look for LEDs illuminated on bottom

Unplug the grid power. Connect all failing drops to vehicles with at least 22 Vdc at the connection. Power back on the grid system. This can also help rest the microprocessor in the reel.

Are all zone Reel Drops now illuminated?

NO

YES

YES – End of Task.

Go to next page.

## No Lights displayed on a Drop Reel (one or more, but not whole zone out)

You will now need a second person and a safe lift devise to get you up to the height of your malfunctioning Drop Reels

Grid Power off.

Start at the Drop Reel harness to Drop Reel quick disconnect. Pay very close attention to the condition of the plug, wires, etc. This can be a pressure point if the wires are at all tight.

Disconnect the quick disconnect. Have your partner turn the power back on. Test for 30 (+/-) Vdc at the plug coming from the grid system.

Do you have adequate Vdc at the plug?

NO

YES

Go to next page.



Drop Reel connection harness plug to Drop Reel quick disconnect plug.

You have a unserviceable Drop Reel or Drop Reel quick disconnect cable. Check for any damage on the cable, at the quick disconnect, etc. Repair any issues. If required, a replacement Drop Reel and cable can be ordered using NSN 6130-01-497-0971.

# No Lights displayed on a Drop Reel (one or more, but not whole zone out)

Inspect all electrical connections of the malfunctioning Drop Reels. This will be all connections and reels for damage, shorts, etc.) This will be the time consuming part of the troubleshooting steps.

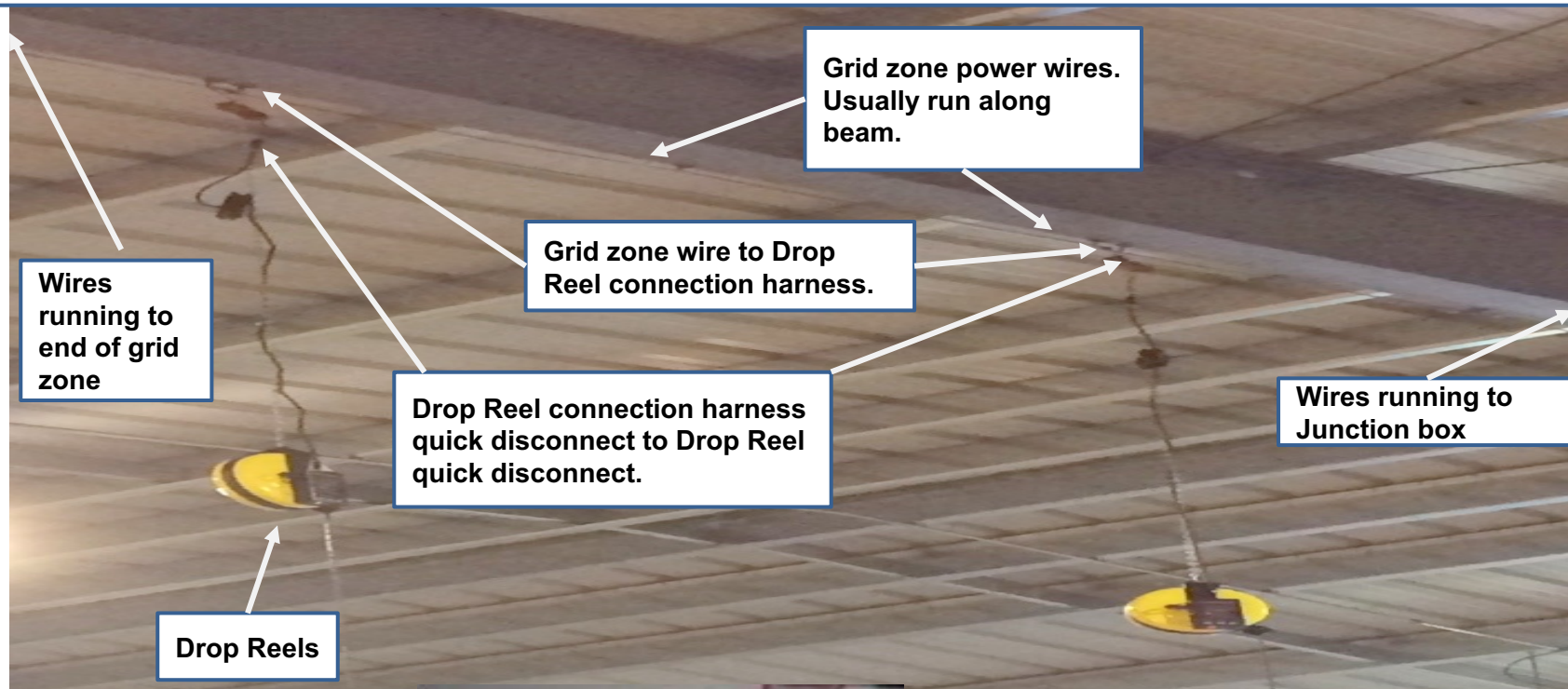

Grid zone wire to Drop Reel connection harness are crimped on. This is usually a lifetime connection unless undue pressure is place on the connection, or during installation a solid wire 'bite' was not achieved.



Grid zone wire to Drop Reel connection harness.



Drop Reel connection harness quick disconnect to Drop Reel quick disconnect.

↓  
Go to next page.

## No Lights displayed on a Drop Reel (one or more, but not whole zone out)

Inspect all electrical connections of the malfunctioning Drop Reels. This will be all connections and reels for damage, shorts, etc.) This will be the time consuming part of the troubleshooting steps.



Grid zone wire to Drop Reel connection harness are crimped on. This is usually a lifetime connection unless undue pressure is placed on the connection, or during installation a solid wire 'bite' was not achieved.

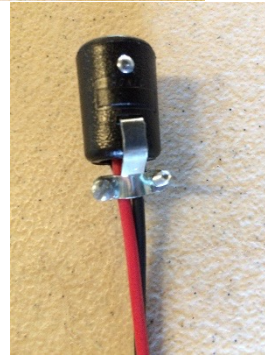

Grid zone wire to Drop Reel connection harness.

Drop Reel connection harness quick disconnect to Drop Reel quick disconnect. If there is any tightness these can disconnect and even short out.

The grid zone wires run in a line above all the drops. If you have several in a row that are out start at the nearest reel to the Junction box and work your way out.

If you need additional assistance contact your supporting FSR.

**END – No Lights displayed on a Drop Reel (one or more, but not whole zone out)**

# No Lights on one or all zones

Check to see if any of the circuit breakers are popped. Are any circuit breakers popped?

YES

NO

Go to next page. Test AC input power



Grid Power Supply – Zone Circuit Breakers

With Grid Power off; Manually reset any popped circuit breaker. Power Grid back on. Did circuit breaker pop again?

YES or would not reset.

NO

Are all zone Reel Drops now illuminated? Description below.

NO

YES



Reel Drop – Look for LEDs illuminated on bottom

YES – End of Task.

Go to next page



# No Lights on one or all zones



Grid Power Supply

Test for AC Voltage coming into the Grid Power supply. Is there adequate AC power coming in?

YES

NO

Fix AC issue in building:  
Must have between 100 – 240 VAC input power to function.



Grid Zone Circuit Breaker test

With Grid Power off; Test the 3 circuit breakers to ensure they are operating adequately. Do you have continuity across circuit breakers?

YES

NO

Go to Page 11.

Manually attempt to reset popped circuit breaker again. Power on Grid System. Is circuit breaker now functioning?

YES

NO

Go to next page.

Are all zone Reel Drops now illuminated?

YES

NO

Go to page 11.

YES – End of Task.

# No Lights on one or all zones



Power off: Open power supply. Disconnect all three zone hot wires (Red, White and Green). The wire connections may be quite stiff. Start at the top with the red connection and work downward disconnecting all 4 wires.

With Grid Power off; Manually reset the malfunctioning circuit breaker again. Power on the system and then power off. Test Circuit breakers.

Is the malfunctioning circuit breaker now working?

YES

NO

Grid Zone Circuit Breaker test continued



Replace malfunctioning circuit breaker

Are all zone Reel Drops now illuminated?

YES – End of Task.

YES

NO

Go to page 11.

## No Lights on one or all zones



Grid zone power wires disconnected.

Test for 30 +/- Vdc being supplied to the zones. The Vdc can vary between 28 to 33 Vdc.

Power off: Open power supply. Disconnect all three zone wires. The wire connections may be quite stiff. Start at the top with the red connection and work downward disconnecting all 4 wires.

Turn on Power Supply. Test for 28 – 31 Vdc between the ground wires (black) and each of the zone hot wires (Red, White, Green) You should have Vdc at each one.

Do you have Vdc between each of the hot wires and ground?

YES

NO

Test for short in zone. Use multimeter to test for continuity between the black ground wire and any of the 3 power wires.

Did you find a short to ground in any of the zones?

No or Yes

You have a power supply issue. Contact your supporting FSR to discuss.

Go to next page.

# No Lights on one or all zones

No short to ground found.



You will now need a second person and a safe lift devise to get you up to the height of your grid system.



Go to next page

Short to ground found.

Reconnect all the zone wires without a short.



Example – Red zone power left disconnected because it has a short to ground.



Power the system back on. You should now have lights on the reels for the zones without the short.

Do you now have lights on the reel drops in the zones without the short?

NO

YES



Reel Drop – Look for LEDs illuminated on bottom

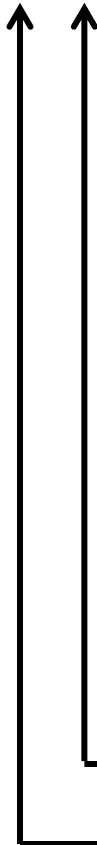

This now lets us know which zone to troubleshoot

## No Lights on one or all zones

Follow the aluminum flexible conduit up from the power supply box. The small box at the end of the conduit is called the Junction box. From here your power and ground wires go out to the individual grid zones. This is where your next set of tests will happen.

**Power off:** Here you will need to check for any loose wires, shorts, damage, etc. Repair any issues found.

Disconnect each of the power wires (Red, White and Green) from their grid zones. You may want to mark the grid zone wires that correspond with the colored hot wires, as these are all red.

Ensure they will not short out when powered on for testing. Have partner Power on system. Test for Vdc between the ground (black wire bundle) and each of the 3 hots. If you do not have Vdc at any there is a break in the wire. Repair Break.



Grid power Junction box.

**Power Off.** Reconnect 1 hot zone wire at a time to its corresponding grid wires and power back on. This should again help to narrow down which zone you are having an issue with.

Again, when the malfunctioning zone is disconnected from the system the other zones should function fine.

Did you find the faulty zone?

YES

NO

Go to next page.

This would be unusual. At this point you will need to inspect 1 zone at a time. Go to next page.

## No Lights on one or all zones

**Power Off.** At this time you should have the functioning zones connected at the Junction box, and the faulty zone wire disconnected from the power wire (red) in the Junction box.

Follow the faulty zone corresponding red wire out from the Junction box to the grid zone. Again, these are all red and black leaving the Junction box, but should be identifiable for the individual zones where it leaves the junction box. Double check to ensure you are following the faulty zone wires.

It is your choice where to start inspecting the zone. Work your way out or start at the furthest point and work your way in. Either way works; because as you go you will need to inspect all components (wires, connections and reels for damage, shorts, etc.) This will be the time consuming part of the troubleshooting steps.

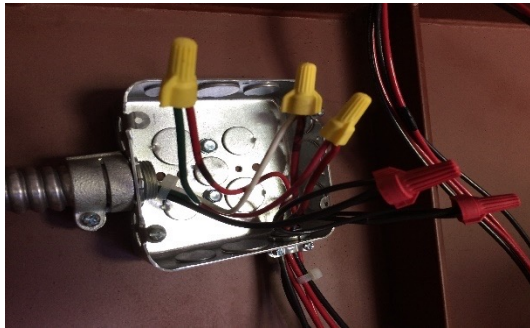

Grid power Junction box. You should have the faulty zone hot wire (red green or white) disconnected.



Example – Grid zones generally run along one beam of a building.

Go to next page.

# No Lights on one or all zones

**Grid Power off.**

While you are working your way across the grid, we would suggest you pay very close attention to the Drop Reel harness to Drop Reel quick disconnect. The condition of the plug, wires, etc. This can be a pressure point if the wires are at all tight.

Disconnect the quick disconnects as you work your way down the grid.

Once finished disconnecting all the quick disconnects on the malfunction zone take the following steps.

1. Reconnect the power wire for the malfunctioning zone at the junction box. Have your partner turn the power back on. If the zone wires are all good (down to the Drop Reel harness) there should be 30Vdc (+/-) at the farthest away Drop Reel harness and all of them in-between. You will need to test each one. Sometimes moving them will reveal if there is a short.
2. While at the farthest away drop reel from the junction box start reconnecting the drop reel quick disconnects. Have someone check each time to ensure there are no issues such as grid shut down, circuit breaker pop, etc.

Did you find the issue and resolve it?

**NO**

**YES**

Go to next page.

YES – End of Task.

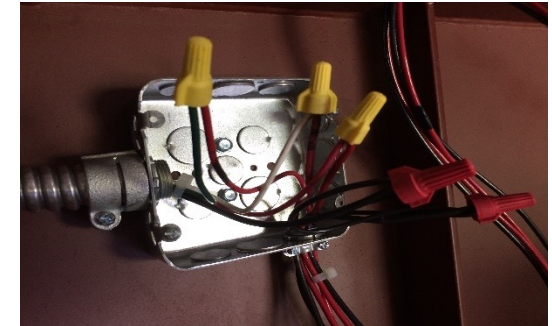

Grid power Junction box with malfunctioning zone re-connected.



Drop Reel connection harness plug to Drop Reel quick disconnect plug. There should be 30Vdc (+/-) when functioning properly to this point.

## No Lights on one or all zones

This is going to be the very tedious and time consuming part. If you have not found the cause of the malfunction yet you will need to inspect the entire zone. Inspect all components (wires, connections and reels for damage, shorts, etc.) on the malfunctioning zone. Start at the junction box and check the entire zone. Check every connection along the way for any damage, shorts, etc.

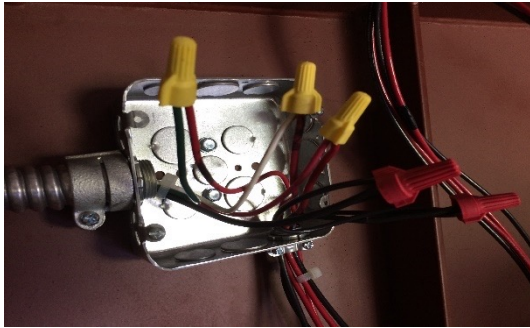

Grid power Junction box. Start here again. Trace the red green or white wire that is connected to the malfunctioning zone red wire.



Example – Grid zones generally run along one beam of a building.

Grid  
Power  
Supply

More info on next page.



# No Lights on one or all zones

Inspect all components (wires, connections and reels for damage, shorts, etc.) on the malfunctioning zone. Start at the junction box and check the entire zone. Check every connection along the way for any damage, shorts, etc.

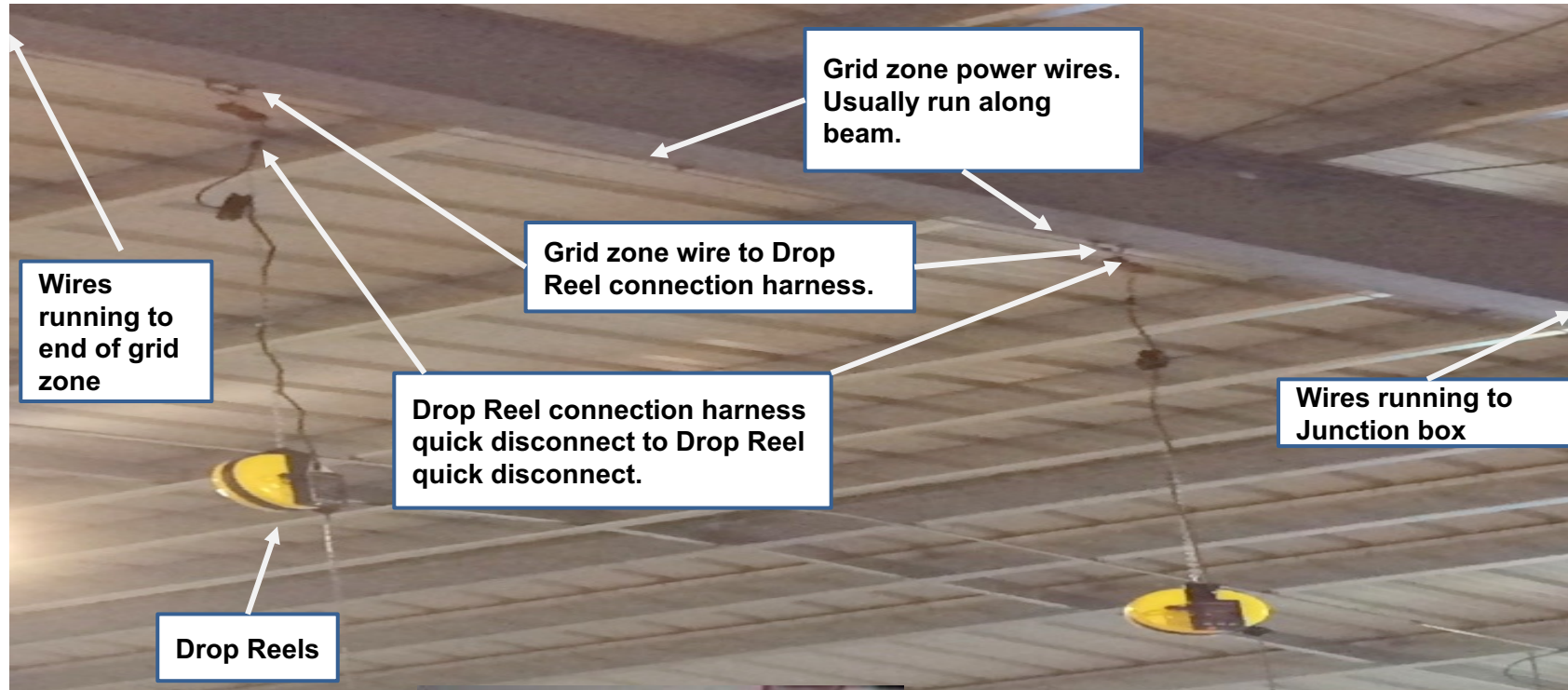

Grid zone wire to Drop Reel connection harness are crimped on. This is usually a lifetime connection unless undue pressure is place on the connection, or during installation a solid wire 'bite' was not achieved.



Grid zone wire to Drop Reel connection harness.

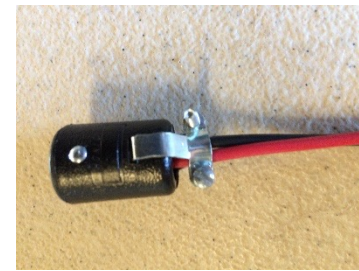

Drop Reel connection harness quick disconnect to Drop Reel quick disconnect.

↓  
End of Task.