

TOMAR Electronics Inc.



MAGNETIC MOUNTING KIT INSTRUCTION SHEET ON 970L-2102 SCORPION LIGHT BARS ONLY

INSTALLER SAFETY MESSAGE

The safe installation of the Tomar 970L Scorpion Mini Light Bar is your first priority. All instructions listed here should be followed and common sense applied to each Light Bar installation to insure safety. Tomar field service should be called if you have any question.

Some important precautions and instructions:

- Installers should have a good understanding of automotive electrical and mechanical systems. The quality of the installation work should equal or surpass OEM standards.
- Protect the vehicle components when drilling into the sheet metal. Metal chips and sharp edges must not be left on the vehicle. Check to see that the drill bit will not damage surrounding components when it penetrates the sheet metal.
- Review all instruction sheets packed with other components of the 970L Scorpion Mini Light Bar and make sure you thoroughly understand each step of the installation before you start.
- Because vehicle roof construction and driving conditions vary, Tomar does not recommend driving a vehicle with a magnetically mounted light bar installed. The light bar could fly off the roof of the vehicle causing injury or damage. Liability for the use of the JMMK Magnetic Mounting Kit shall be the sole responsibility of the user.
- File these instructions in a safe place for future reference.

Perform a final inspection of the installation to insure that the 970L MINI Scorpion Light Bar is operating properly. Failure to follow all safety procedures and instructions

may result in serious injury, property damage or death to you or others.

I. GENERAL INFORMATION

This instruction sheet provides procedures to install the JMMK Magnetic Mounting Kit to the Tomar 970L Mini Scorpion Light Bar and mount the assembly to the vehicle. In order to complete the installation, you must have purchased the 970L Scorpion Mini Light Bar and a JMMK Magnetic Mounting Kit. Your 970L Mini Light Bar should also have the correct lamp configuration you have ordered.

II. UNPACKING

Check to see that all components shown in Figures 1 and 2 are included. Check your packing lists carefully.

III. ASSEMBLY

- A. Turn the light bar assembly upside down while protecting the top surface from scratches.
- B. Insert a rubber grommet into the center hole of each magnet. Insert a 3/8" spacer into the center hole of each grommet.
- C. Install a ¼-20 truss head machine screw from the underside of the magnet through the previously installed spacer
- D. Insert the truss head screw through the mounting hole in the end of the mounting bracket and secure with a ¼" internal tooth lock washer and ¼ - 20 acorn nut. Repeat to assemble the other three magnets.
- E. Place the light bar assembly on the vehicle roof. It should be located approximately over the drivers head and centered on the vehicle. Insure that the ends of the light bar are equidistant from the roof

gutters and the distance from the windshield to each end of the unit is the same.

F. Inspect the entire assembly to insure that all fasteners and brackets are tight.

WARNING!!

The holding power of magnetic mounting systems is dependent upon surface finish, surface flatness, and thickness of the steel mounting surface. Therefore, to maximize the holding power of the magnets:

- Mounting surface and magnets must be kept clean, dry and free of foreign particles that would prevent good surface contact.
- Ensure that the mounting surface is flat. Magnets should not be used on curved surfaces.
- Magnetic mounting systems should not be used on vehicles with vinyl tops.
- To prevent sliding of light assembly on mounting surface, quick acceleration and hard stops should be avoided.
- Magnetic mounting systems should only be used on Tomar 970L Scorpion Mini Light Bars.

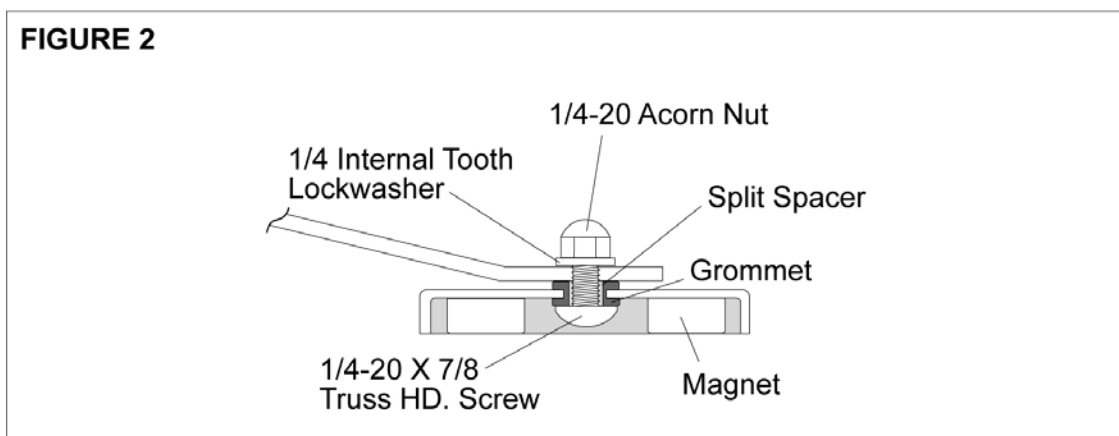
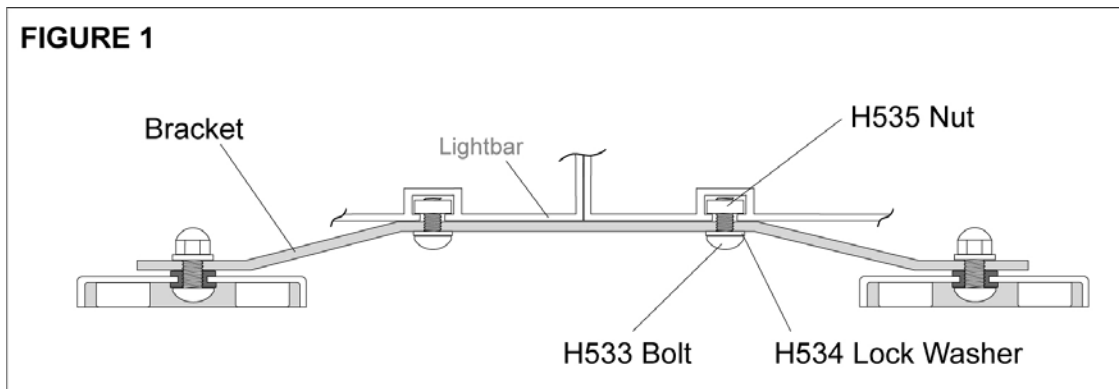

TOMAR MODEL 970L-2102-0101 SWITCH CONTROL

ELECTRICAL

Input Voltage:

10 – 16 VDC

Current Draw – In SINGLE FLASH 75 ALTERNATE @ 12.8VDC:

High Power Model 6 Amps

Low Current Model 3 Amps

SELECTING FLASH PATTERN

Cycle Forward

With the unit turned on, press the Pattern selection switch once and then release. Continue until the desired pattern is reached. The last pattern selected will become the default pattern.

Reset to Pattern #1

With the unit turned on, press and hold the Pattern selection switch for more than three seconds. The unit will flash three times then return to Pattern #1 to indicate that it has reset. Pattern #1 will become the default pattern.

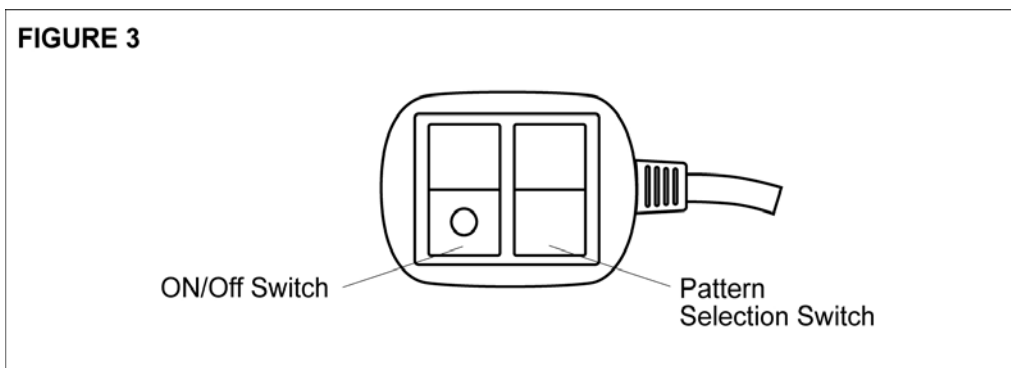

Note: If ordered with a straight cord (no cigar plug) tapping the white wire to +12 will have the same effect as pressing the pattern selection switch.

SELECTABLE FLASH PATTERNS

PATTERN #	FLASH PATTERNS	RATES	
01)	FRONT REAR SIDE ALTERNATING	NEOBE 150	***DEFAULT**
02)	FRONT REAR SIDE ALTERNATING	NEOBE 75	
03)	FRONT REAR SIDE ALTERNATING	DOUBLE 250	
04)	FRONT REAR SIDE ALTERNATING	DOUBLE 125	
05)	FRONT REAR SIDE ALTERNATING	SINGLE 375	
06)	FRONT REAR SIDE ALTERNATING	SINGLE 150	
07)	FRONT REAR SIDE ALTERNATING	SINGLE 75	
08)	FRONT REAR ALTERNATING	NEOBE 150	
09)	FRONT REAR ALTERNATING	NEOBE 75	
10)	FRONT REAR ALTERNATING	DOUBLE 250	
11)	FRONT REAR ALTERNATING	DOUBLE 125	
12)	FRONT REAR ALTERNATING	SINGLE 375	
13)	FRONT REAR ALTERNATING	SINGLE 150	
14)	FRONT REAR ALTERNATING	SINGLE 75	
15)	FRONT REAR ALTERNATING WITH SIDE	NEOBE 150	
16)	FRONT REAR ALTERNATING WITH SIDE	NEOBE 75	
17)	FRONT REAR ALTERNATING WITH SIDE	DOUBLE 250	
18)	FRONT REAR ALTERNATING WITH SIDE	DOUBLE 125	
19)	FRONT REAR ALTERNATING WITH SIDE	SINGLE 375	
20)	FRONT REAR ALTERNATING WITH SIDE	SINGLE 150	
21)	FRONT REAR ALTERNATING WITH SIDE	SINGLE 75	
22)	LEFT RIGHT ALTERATING	NEOBE 150	
23)	LEFT RIGHT ALTERATING	NEOBE 75	
24)	LEFT RIGHT ALTERATING	DOUBLE 250	
25)	LEFT RIGHT ALTERATING	DOUBLE 125	
26)	LEFT RIGHT ALTERATING	SINGLE 375	
27)	LEFT RIGHT ALTERATING	SINGLE 150	
28)	LEFT RIGHT ALTERATING	SINGLE 75	
29)	CIRCULAR	NEOBE 150	
30)	CIRCULAR	NEOBE 75	
31)	CIRCULAR	DOUBLE 250	
32)	CIRCULAR	DOUBLE 125	
33)	CIRCULAR	SINGLE 375	
34)	CIRCULAR	SINGLE 150	
35)	CIRCULAR	SINGLE 75	
36)	ALTERNATING ALL ON/OFF	NEOBE 150	
37)	ALTERNATING ALL ON/OFF	NEOBE 75	
38)	ALTERNATING ALL ON/OFF	DOUBLE 250	
39)	ALTERNATING ALL ON/OFF	DOUBLE 125	
40)	ALTERNATING ALL ON/OFF	SINGLE 375	
41)	ALTERNATING ALL ON/OFF	SINGLE 150	
42)	ALTERNATING ALL ON/OFF	SINGLE 75	