



TRX SERIES LIGHTS

TRX-03 TRX-06 TRX-10

Product Manual



Wiring

Power Wires

- Red to +Vdc
- Black to -Vdc

Wire Runs

The table below lists the maximum recommended wire run for the power and ground cables in feet.

Part Number	Lamps	WIRE GAUGE					
		18	16	14	12	10	8
TRX-03	1	89	142	225	361	575	914
TRX-06	1	51	81	129	206	328	522
TRX-10	2	25	40	64	103	164	261

Common Switch Wiring Configuration

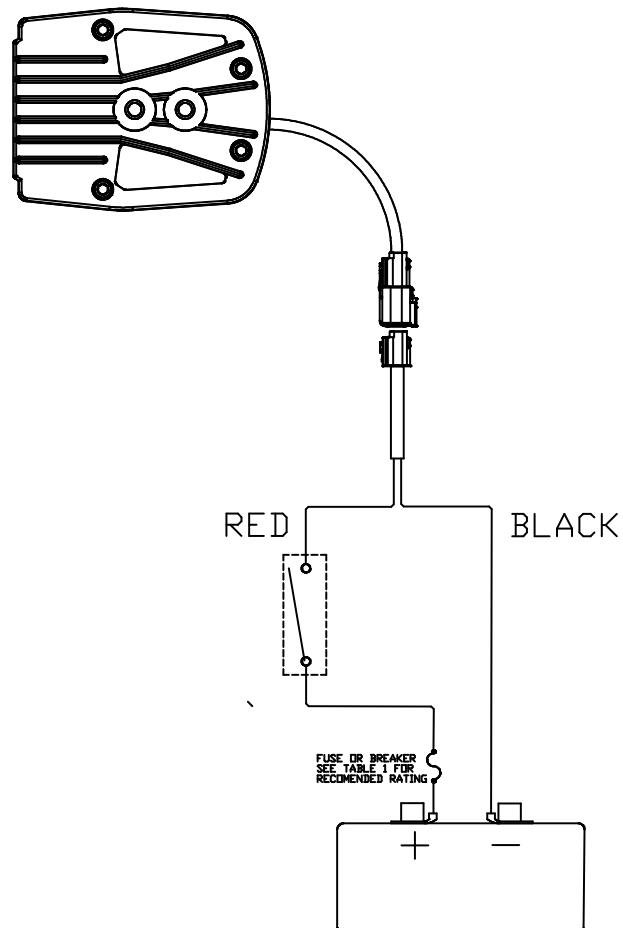



Mounting

TRX lightbars include L shape mounting brackets designed to secure the lightbar to a flat surface. The bracket will allow a 135° range of motion. For additional mounting options visit www.tomaroffroad.com.

1. Attach the mounting foot to the lightbar using the 1/4 -20 socket head screws and 1/4" flat washers included with the lightbar, leaving the screws finger tight.
2. Place the lightbar with attached mounting feet on a flat surface that has sufficient strength to support its weight. Using the holes in the mounting brackets as a template mark the location of the mounting holes. The mounting holes in the bracket are designed to free fit 1/4 inch hardware. Recommended drill sizes for 1/4" hardware are 17/64" for clearance holes and 13/64 for tapped holes. Note: the hole pattern on the foot is on 2" centers. For the hole spacing between the mounting feet refer to the Dimensions section below.
3. Once the lightbar is secured to the mounting surface, adjust the lightbar to the desired angle and tighten the 1/4-20 socket head screws to approx. 36 in/lb.

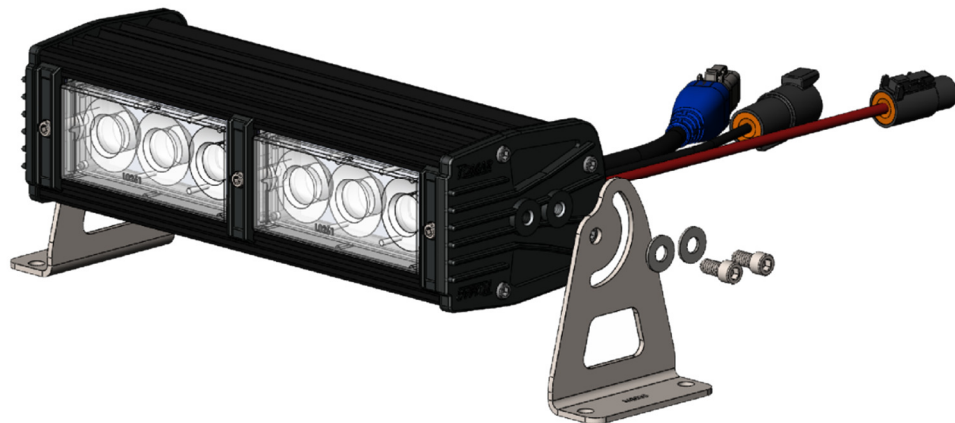



Dimensions

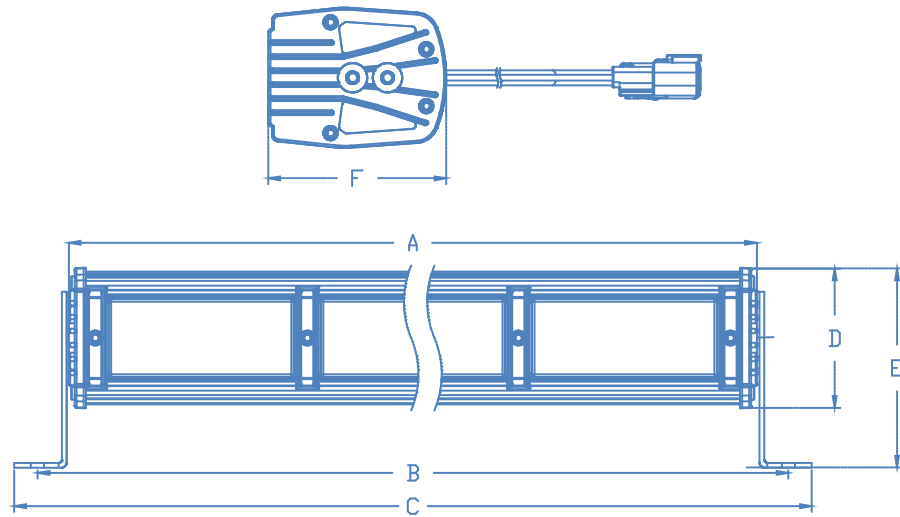

Outside Dimensions

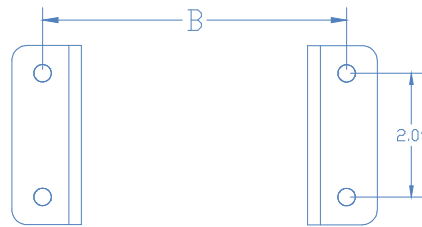

Mounting Hole Spacing

Nominal Length	Lamps	Dim "A"	Dim "B"	Dim "C"	Dim "D"	Dim "E"	Dim "F"
3	1	3.41	4.66	5.66	3.00	4.25	3.82
6	1	5.68	6.93	7.93	3.00	4.25	3.82
10	2	10.23	11.48	12.48	3.00	4.25	3.82



Recommended Fuse/Breaker Sizing

Part Number	Lamps	Amp draw @13.8Vdc	Fuse/Breaker Size (A)
TRX-03	1	1.3	3
TRX-06	1	2.1	5
TRX-10	2	4.2	10

Replacing a lamp module

All TRX lamp modules are interchangeable and can be used in any position on the lightbar. This offers the flexibility to configure a lightbar for any mission with perfect balance of flood, spot or dual color amber white modules.

With this modular design the replacement of a TRX Lamp couldn't be easier. Each module is hermetically sealed so replacement will not compromise the watertight integrity of the lightbar or void the warranty.

To replace a lamp module simply remove the two lamp clips using a 9/64" hex tool. Unplug the lamp from the waterproof connector, plug the new lamp in and reattach the lamp clips.

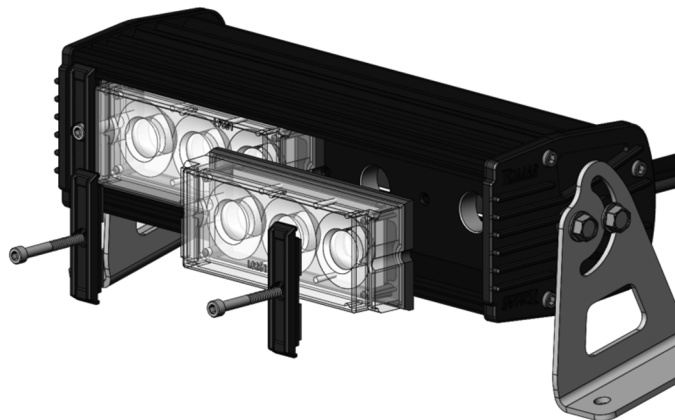

Maintenance

The best cleaning method is to gently wash the lightbar with a solution of mild soap and lukewarm water, using a soft cloth or sponge to loosen any dirt or grime. Thoroughly rinse with clean water to remove any cleaner residue and dry the surface with a soft cloth to prevent water spotting.

If using a high-pressure water cleaner and/or a steam cleaner the pressure should not exceed 1,450psi. The use of additives to the water and/or steam should also be avoided.

Important Considerations for Lexan lenses:

- Never use abrasive or highly alkaline cleaners.
 - Never use aromatic or halogenated solvents like toluene, benzene, gasoline, acetone or carbon tetrachloride.
 - Contact with harsh solvents such as methyl ethyl ketone (MEK) or hydrochloric acid can result in surface degradation and possible crazing.
 - Never scrub lenses with brushes, steel wool or other abrasive materials.