

NOTICE de MONTAGE

ASSEMBLY INSTRUCTIONS

Lits superposés en métal et tissu avec
sommier et échelle droite fixe
couchage 90 x 190 cm

TPTNY104H022



IMPORTANT - A CONSERVER POUR CONSULTATION ULTERIEURE - A LIRE ATTENTIVEMENT.
IMPORTANT - KEEP FOR FUTURE REFERENCE - READ CAREFULLY.

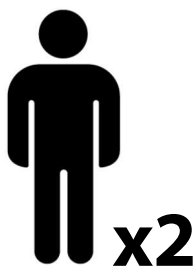
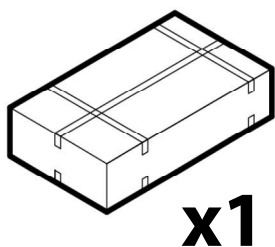

90mn



QUALITÉ
certifiée

SENHO
Home Collection
www.senho.fr

© ALL RIGHTS RESERVED



Séparez les éléments avant de trier



FR
Donnez ou recyclez
vos meubles.



Association



Magasin



Déchèterie

<https://quefairedemesdechets.fr>

FR. INSTRUCTIONS D'UTILISATION / MISES EN GARDE IMPORTANTES

Lisez attentivement le manuel d'instructions avant de vous servir de ce produit. Conservez le manuel.

Produit à monter soi-même. Ce produit est destiné à un usage domestique.

Veillez à le positionner de façon stable avant utilisation. Attention aux zones de pincement lors de son utilisation.

Le produit doit être assemblé par l'utilisateur.

Si des sacs en plastiques sont utilisés pour l'emballage, les sacs en plastique peuvent être dangereux.

Pour éviter tout risque d'étouffement, gardez-les hors de portée des bébés et des enfants.

AVERTISSEMENT: Les lits hauts et le lit supérieur dans un lit superposé ne conviennent pas aux enfants de moins de 6 ans en raison du risque de blessure en tombant de ces lits.

AVERTISSEMENT: Si les lits hauts ou superposés ne sont pas utilisés correctement, ils peuvent présenter un risque grave de blessure par strangulation.

N'attachez ou ne suspendez jamais des objets du lit superposé supérieur qui ne seront pas utilisés avec ce lit.

Ces choses comprennent - mais ne sont pas limitées à - les cordes, les ficelles, les ceintures, les crochets et les sacs.

AVERTISSEMENT: Les enfants peuvent se retrouver coincés entre le lit et un mur, ou un mur de toit incliné, le plafond, des meubles adjacents (comme les armoires) ou d'autres objets.

Pour éviter tout risque de blessure grave, la distance entre la barrière de sécurité supérieure et les éléments environnants ne doit pas dépasser 75 mm ou doit être supérieure à 230 mm.

AVERTISSEMENT: N'utilisez pas le lit superposé supérieur ou un lit haut si une partie de la structure est manquante ou cassée. Les pièces de rechange doivent être demandées au fabricant ou à un atelier compétent. Il est essentiel que les instructions du fabricant sur les instructions de montage soient suivies.

La taille recommandée du matelas à utiliser avec le lit est de **900mm x 1900mm**,

l'épaisseur maximale du matelas ne doit pas dépasser **150mm**.

Les matelas doivent être aérés pour maintenir une faible humidité et pour empêcher l'humidité de s'accumuler dans le lit et ses environs. Les fixations mises en place lors de l'assemblage doivent toutes être correctement serrées et régulièrement vérifiées. Serrez à nouveau les fixations si nécessaire.

Ce produit est conforme aux exigences de la norme de sécurité européenne EN 747-1,-2:2012+A1:2015.

Importé par SENHO SAS 4 rue d'Isly 59000 Lille, France.

EN. INSTRUCTIONS FOR USE / IMPORTANT WARNINGS

Read the instruction manual carefully before using this product. Keep the manual.

The product must be assembled by the user. This product is intended for home use.

Be sure to position it stably before use. Pay attention to pinching areas when using it.

The product must be assembled by the user.

If plastic bags are used for packaging, plastic bags can be dangerous.

To avoid choking, keep them out of reach of babies and children.

WARNING: high beds and the upper bed in a bunk bed are not suitable for children under 6 years old because of the risk of injury from falling from such beds.

WARNING: if the high or bunk beds are not used correctly, they can present a serious risk of injury from strangulation.

Never attach or suspend things from the upper bunk bed that are not going to be used with that bed.

Such things include - but are not limited to - cords, string, sashes, hooks, belts and bags.

WARNING: children can find themselves trapped between the bed and wall, or inclined roof wall, ceiling, adjacent pieces of furniture (such as cupboards) or other items. To avoid any risk of serious injury, the distance between the upper safety barrier and surrounding items should not exceed 75 mm - or the distance should be greater than 230 mm.

WARNING: do not use the upper bunk bed or a high bed if a part of the structure is missing or broken.

Spare parts should be requested from the manufacturer or shop.

It is essential that the manufacturer's instructions on assembly instructions are followed.

The recommended size of the mattress to be used with the bed is **900mm x 1900mm**,

the maximum mattress thickness is **150mm**.

Mattresses must be aired to maintain a low humidity and to stop moisture building up in the bed and its surroundings.

The fastenings put in place on assembly should all be properly tightened and regularly checked.





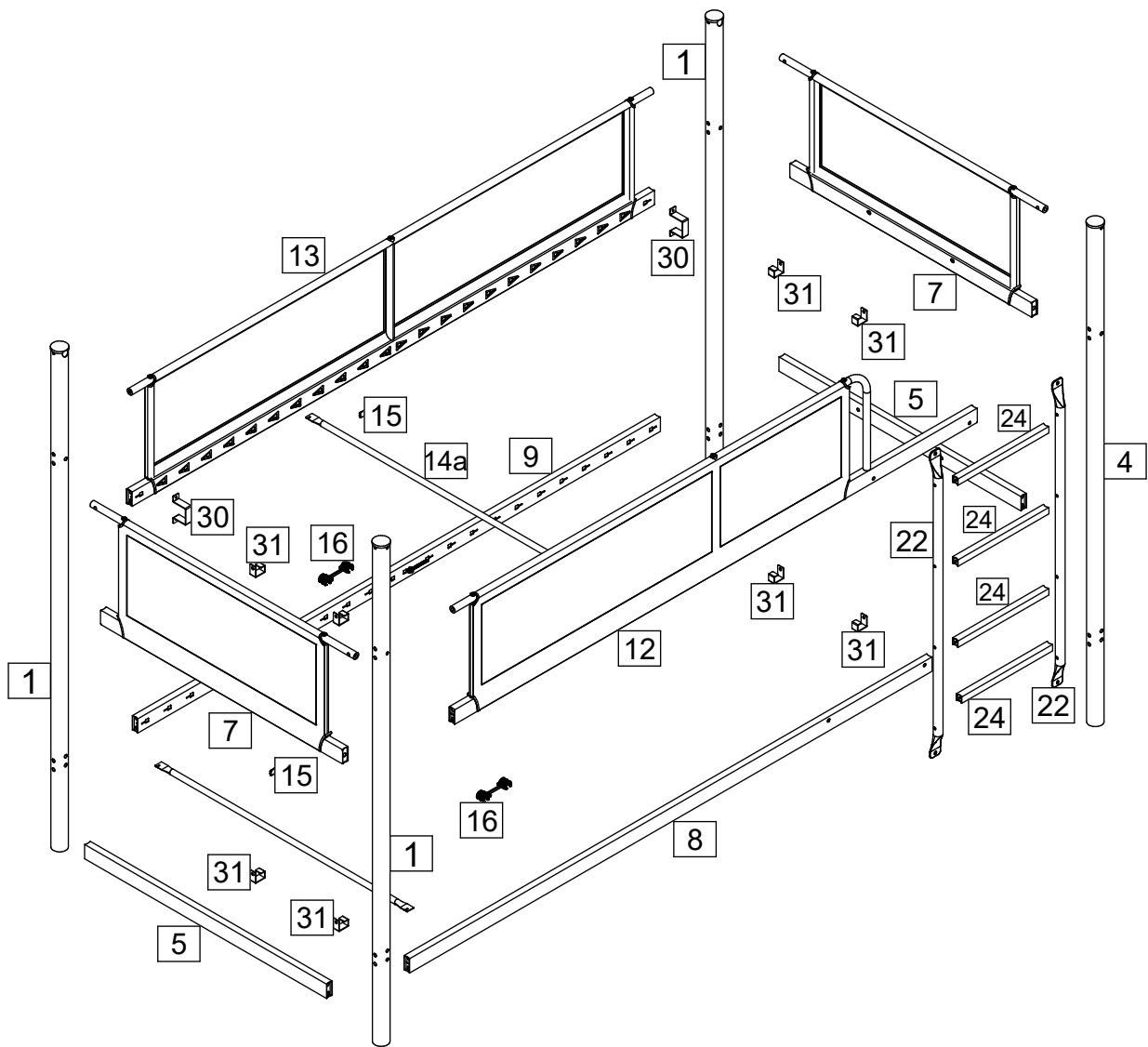

Retighten the fastenings as necessary.

This product complies with the requirements of the European Safety Standard EN 747-1,-2:2012+A1:2015.

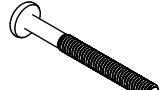
Imported by SENHO SAS 4 rue d'Isly 59000 Lille, France.



CODE	QTY	CODE	QTY	CODE	QTY
1	3PCS	15	96PCS		
4	1PC	16	46PCS		
5	2PCS	22	2PCS		
7	2PCS	24	4PCS		
8	1PC	30	2PCS		
9	1PC	31	8PCS		
12	1PC				
13	1PC				
14a	48PCS				

A		M8X 68MM3 in 1	16PCS	B		M8 X 70MM	12PCS
C		M6 X 65MM3 in 1	3PCS	D		M6 X 40MM	8PCS
E		M6 X17MM	12PCS	F		M6 X 12MM	4PCS
G		4MM	1PC				



1 X 3



4 X 1

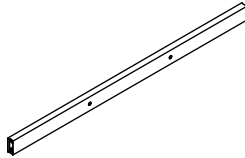

5 X 2

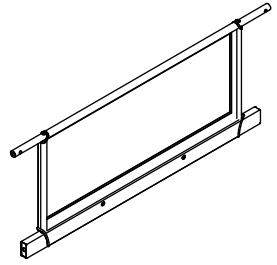

7 X 2

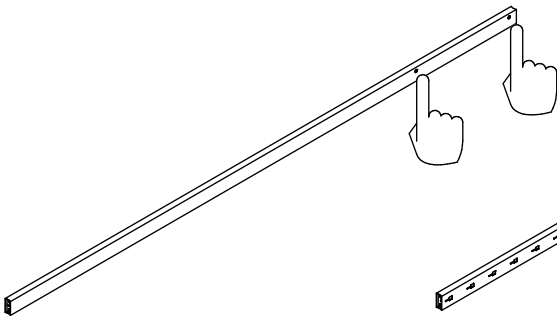

8 X 1

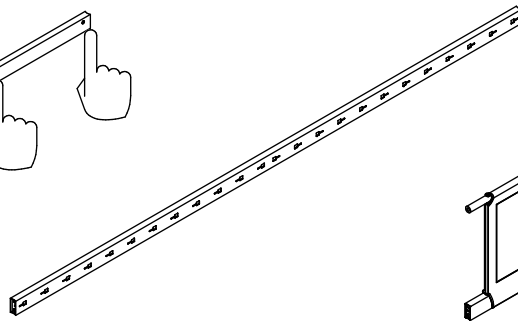

9 X 1

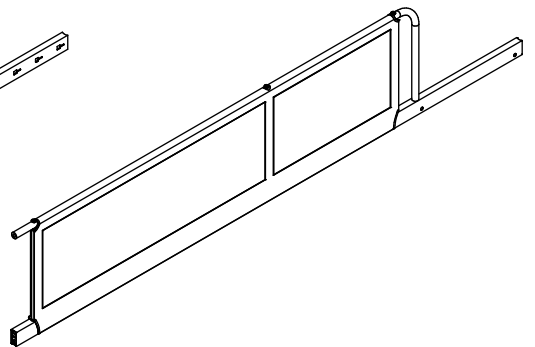

12 X 1

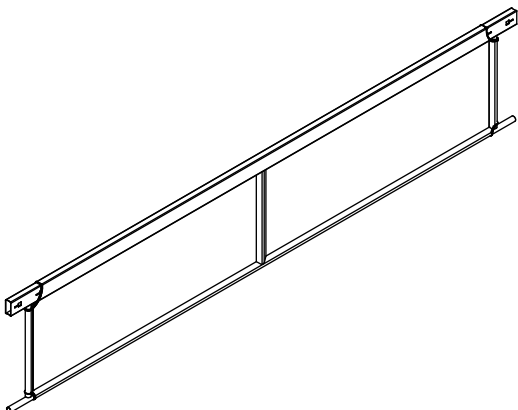

13 X 1

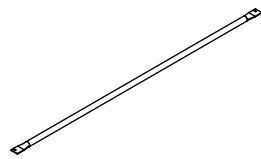

14a X 48



15 X 96

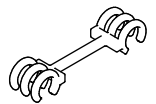

16 X 46

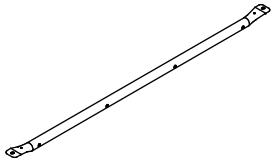

22 X 2

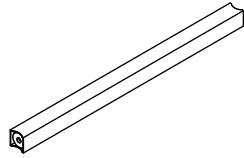

24 X 4

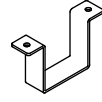



30 X 2



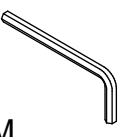

31 X 8

1

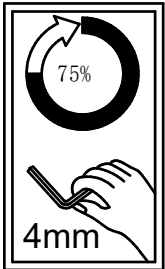
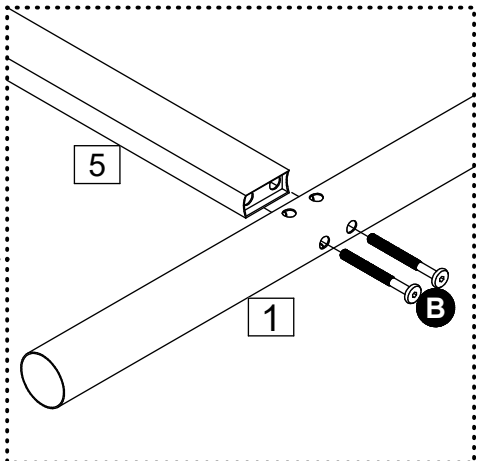
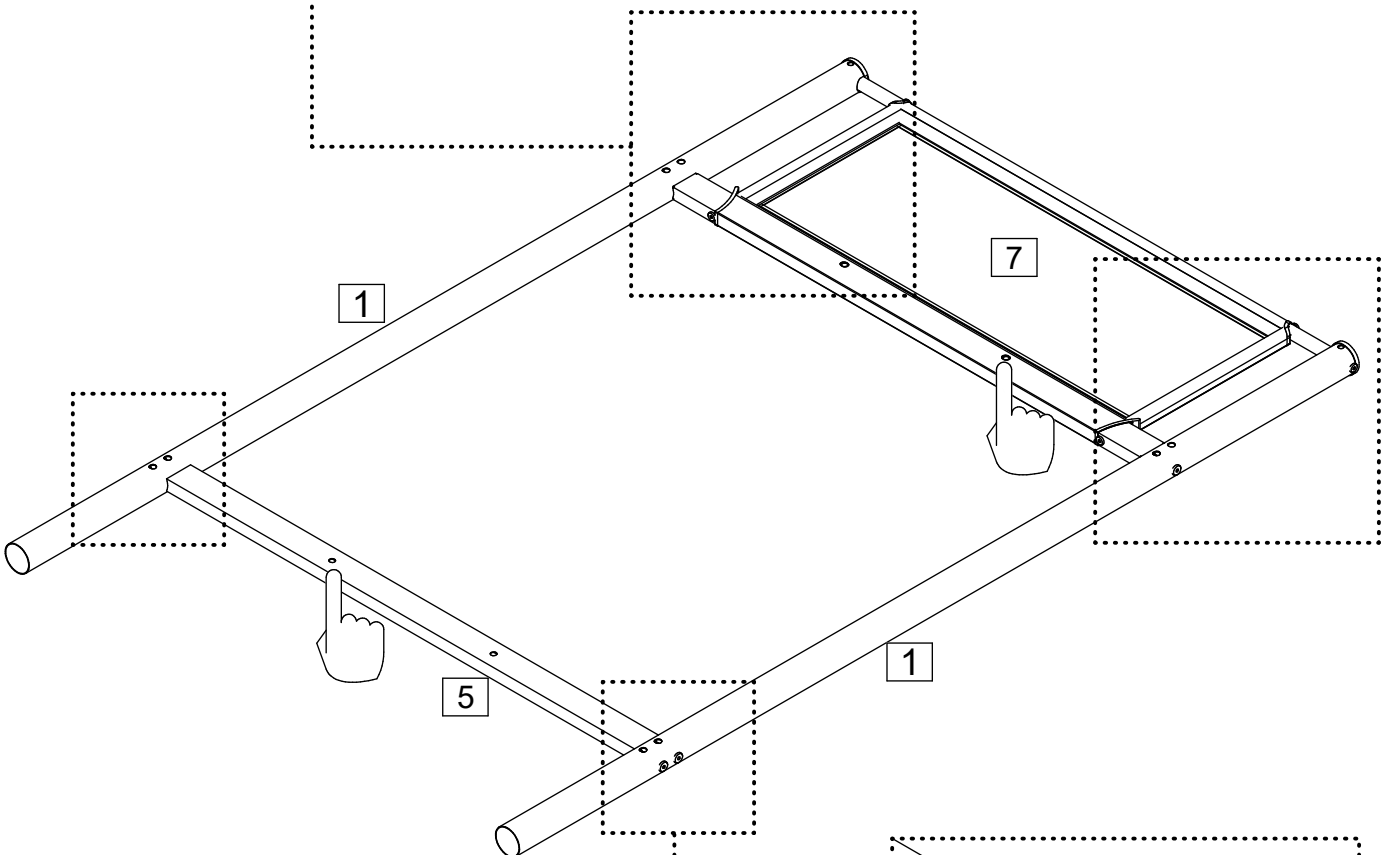
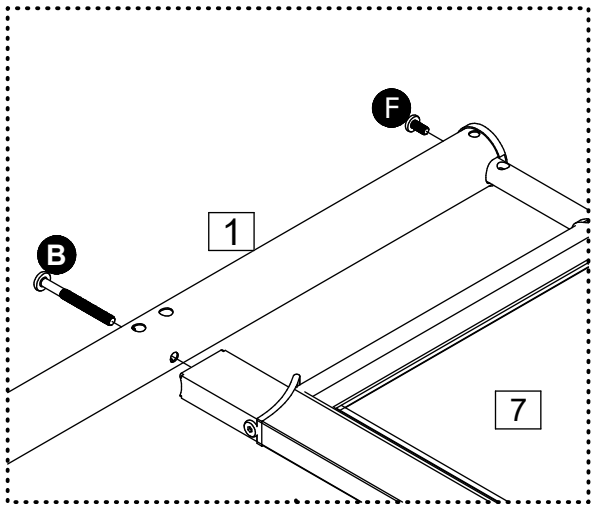
B  M8 X70MM	6 PCS	F  M6 X12MM	2 PCS
		G  4 MM	1PC

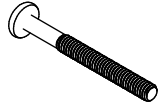

2

B  M8 X70MM	6PCS	F  M6 X12MM	2 PCS
		G  4 MM	1PC

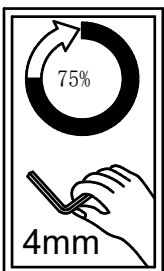
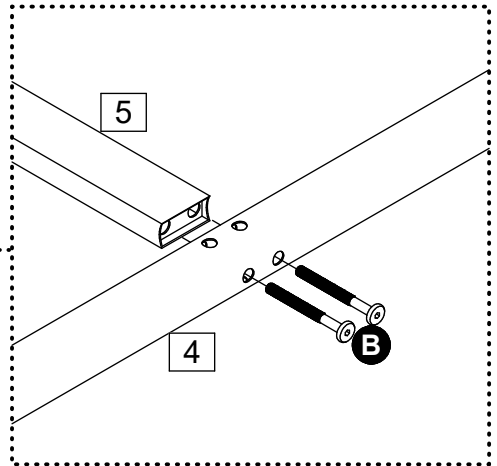
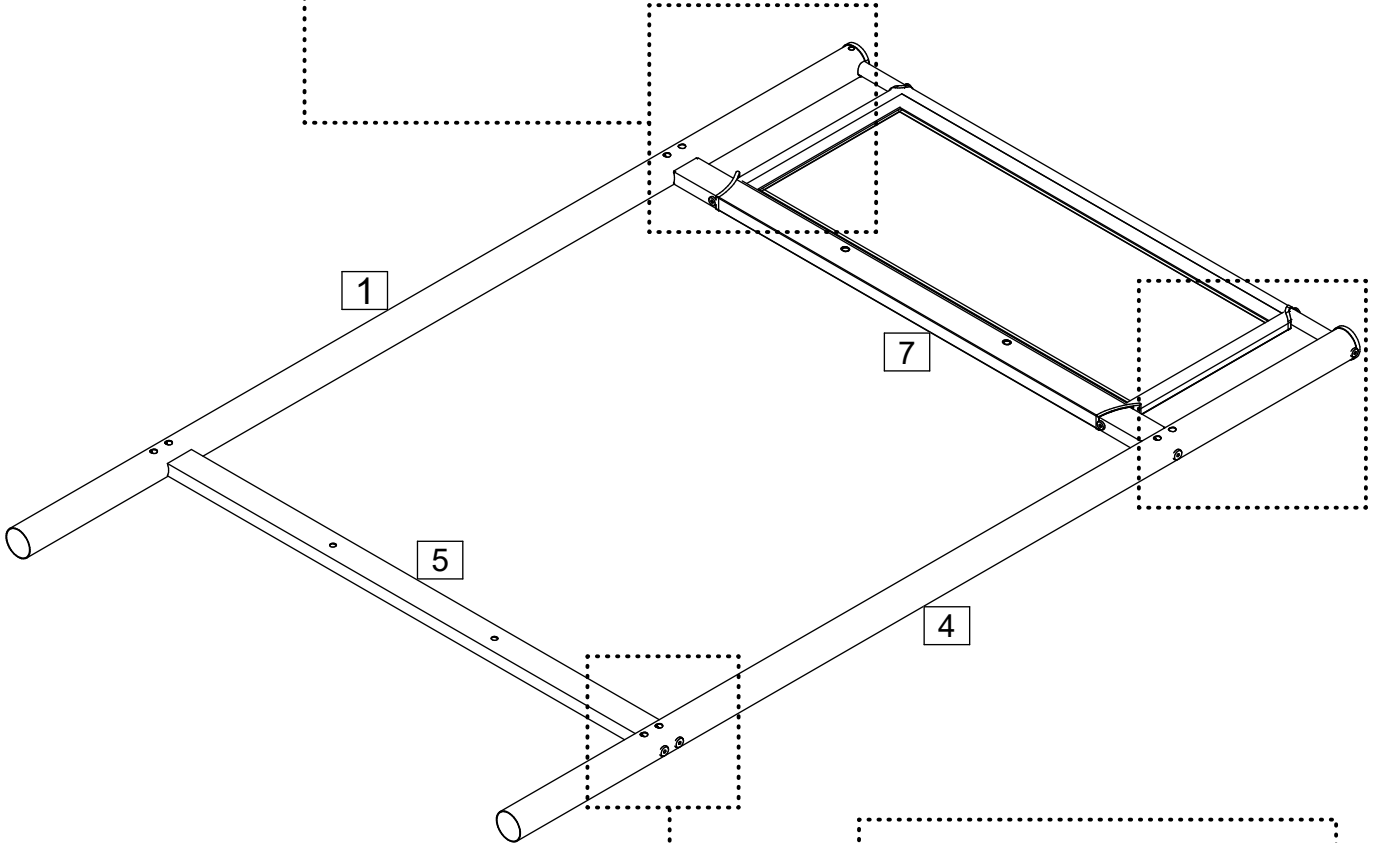
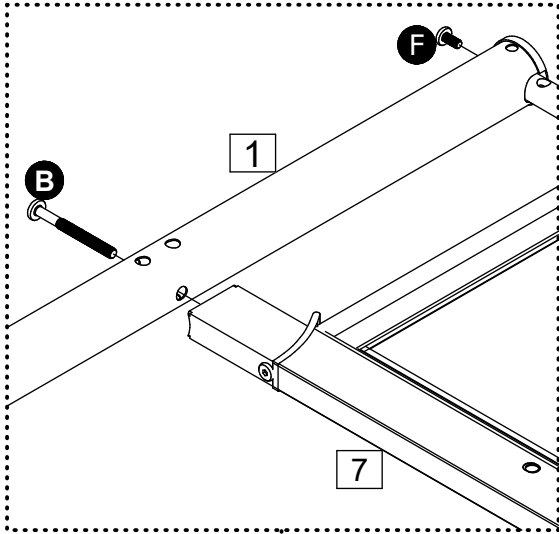

3

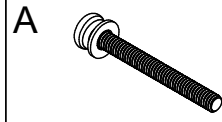

M8X68MM3 in 1 8PCS

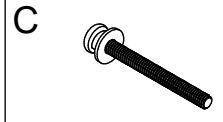

M6 X65MM3 in 1 3PCS



4 MM 1PC

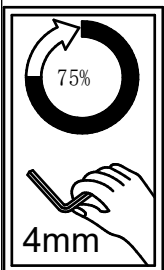
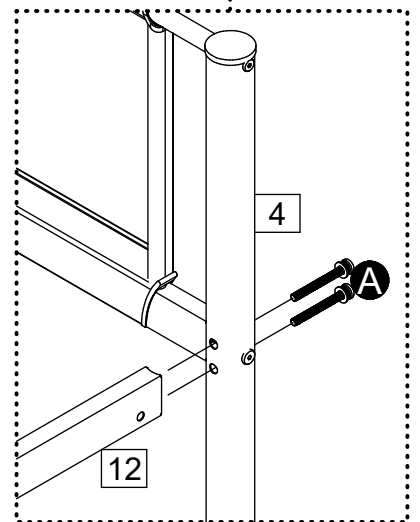
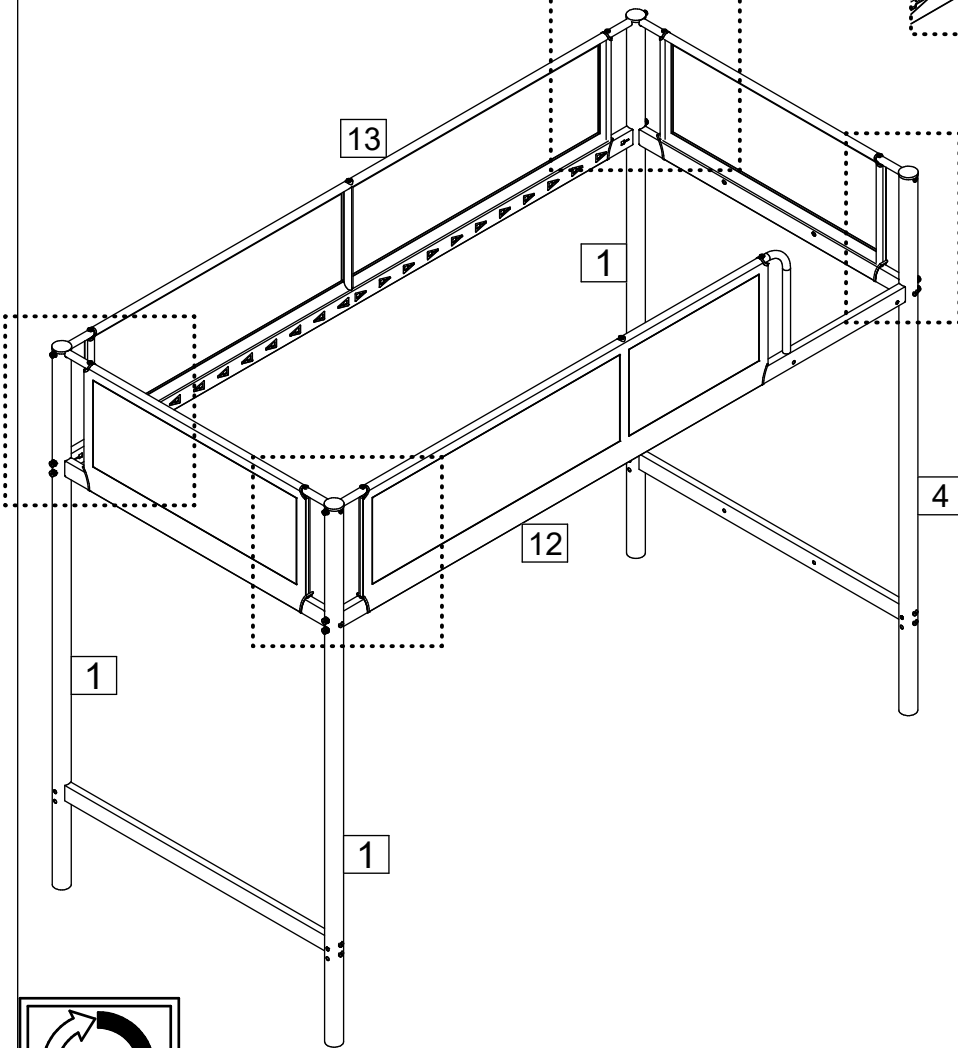
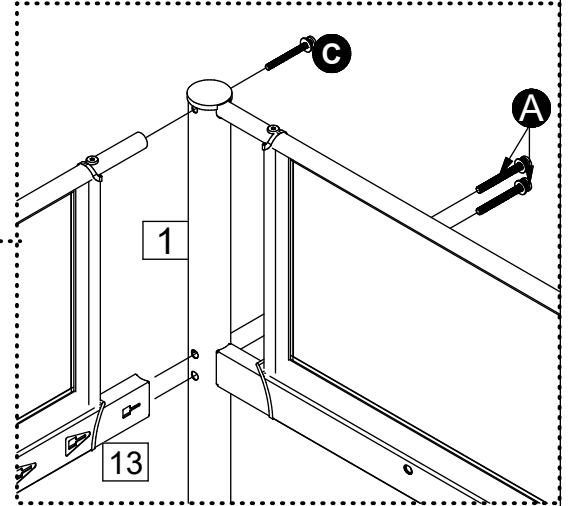

4

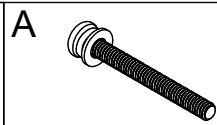

M8X68MM3 in 1 8PCS

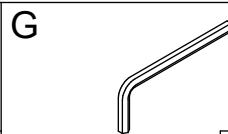

4 MM

1PC

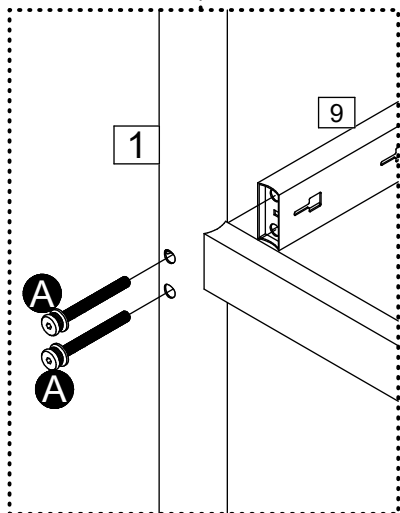
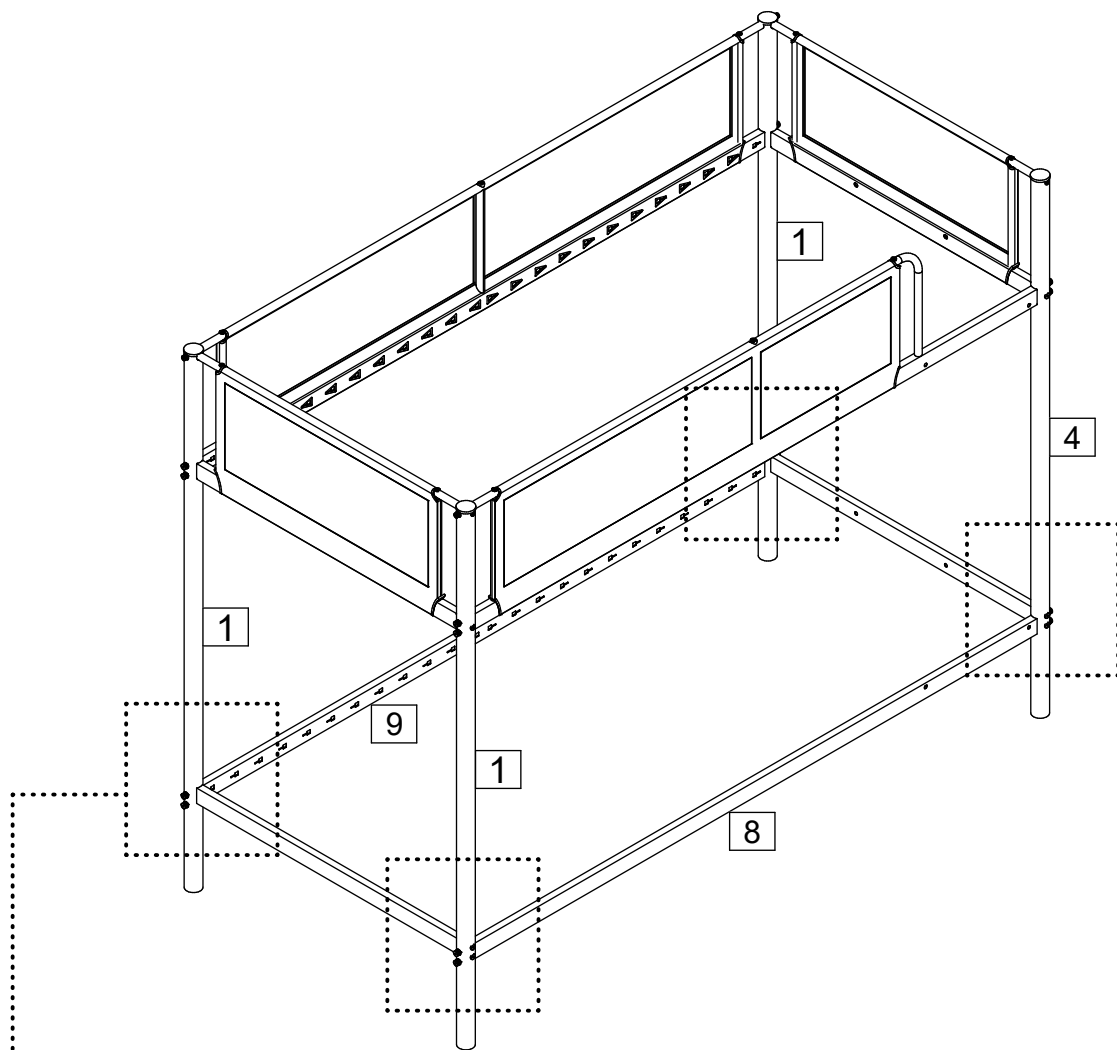

5

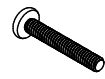
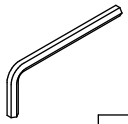
<p>D</p>  <p>M6 X40MM</p> <p>8PCS</p>	<p>G</p>  <p>4MM</p> <p>1PC</p>
---	---

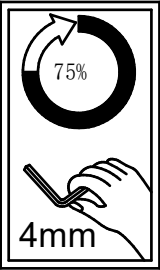
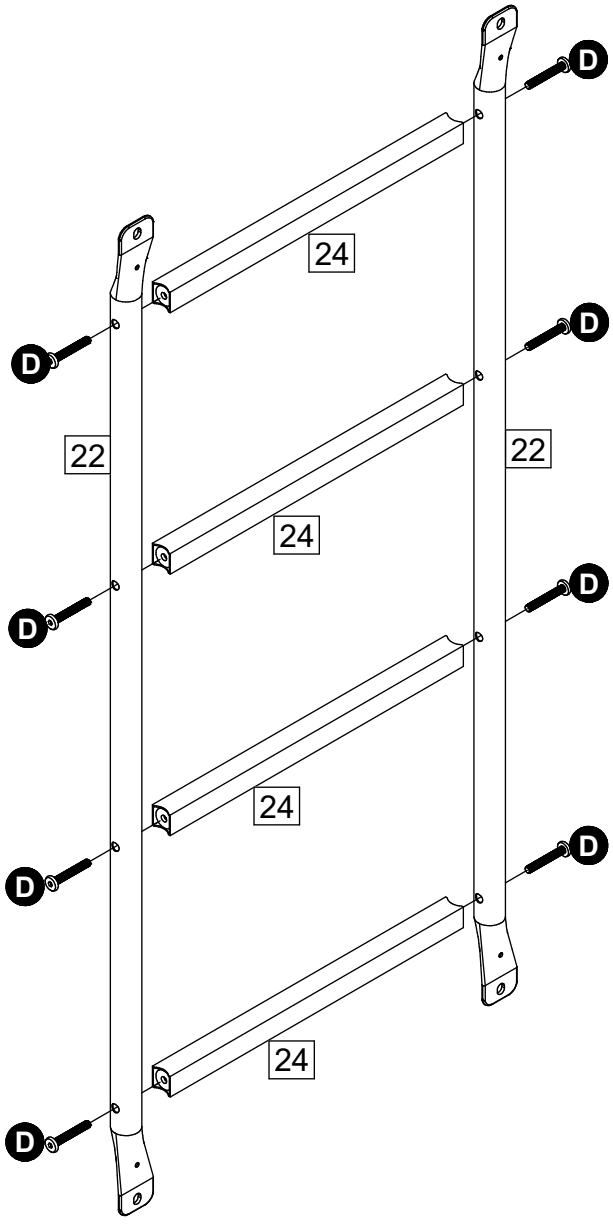

6

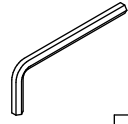
E  M6 X17MM	G  4 MM	4 PCS	1PC
---	---	-------	-----

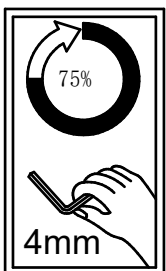
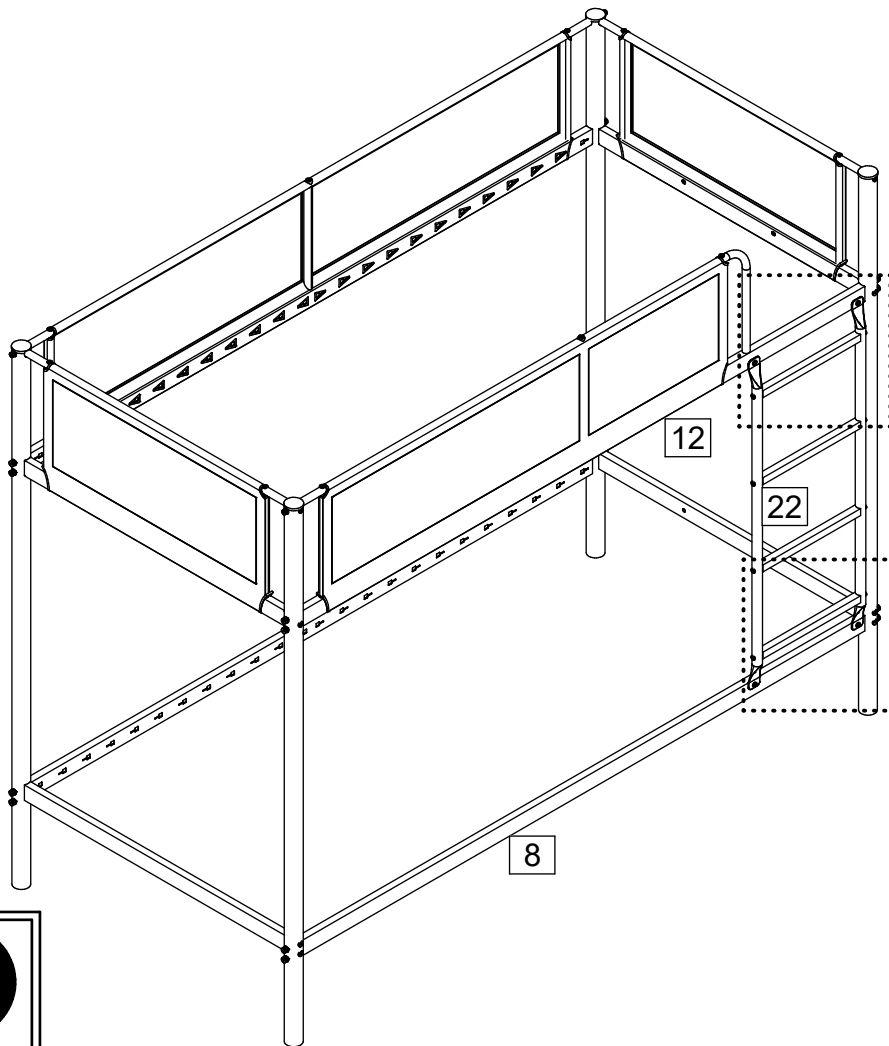
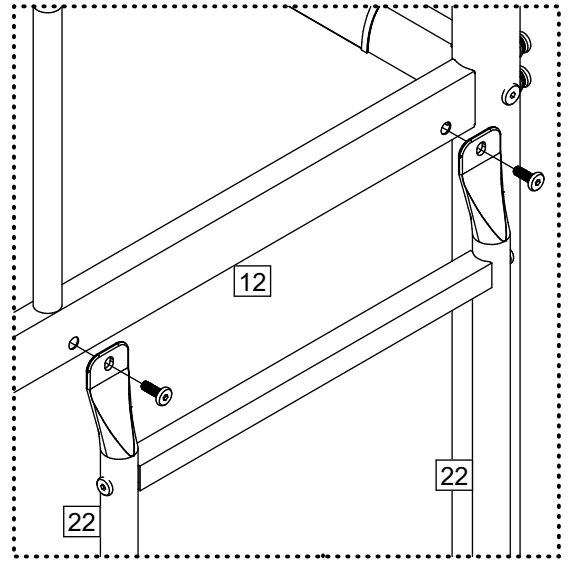

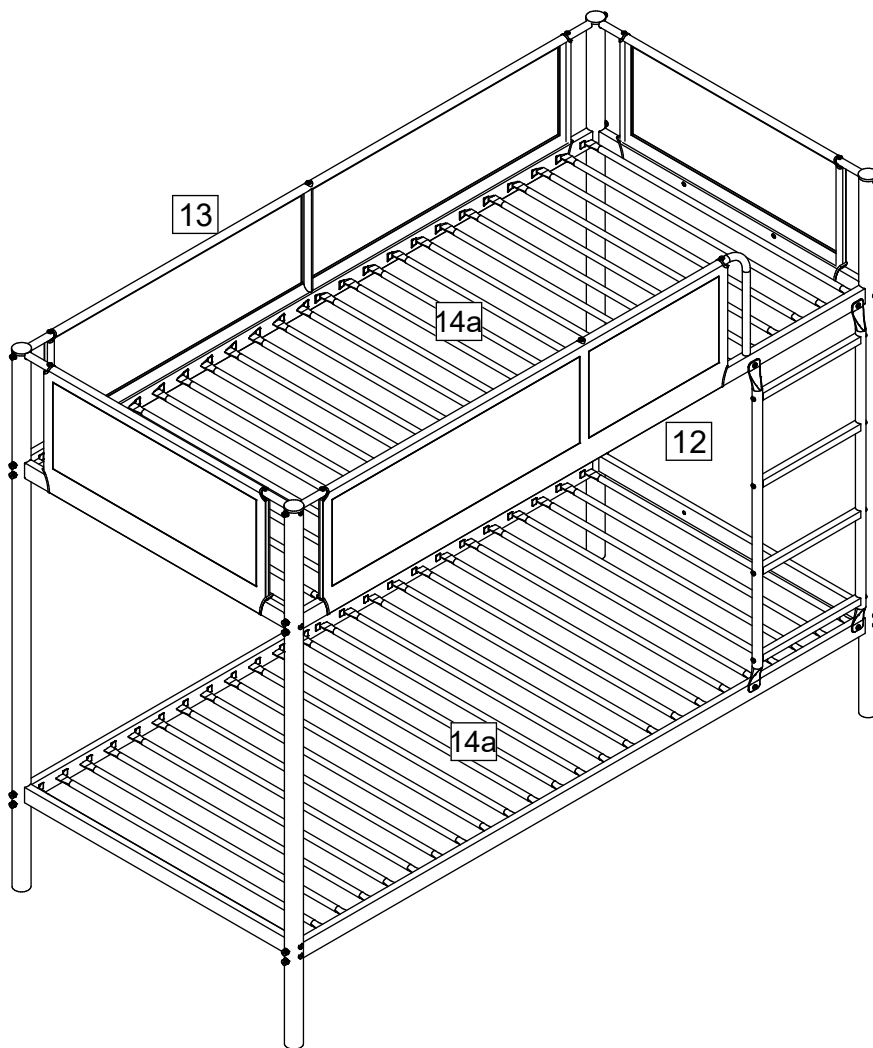
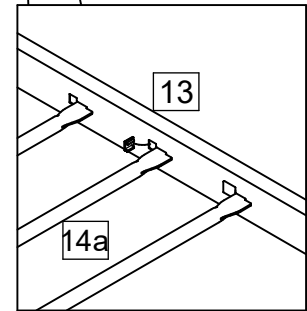
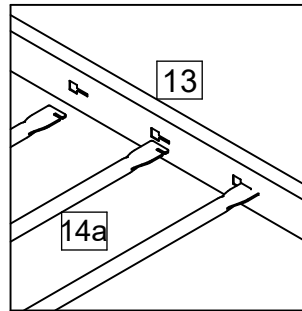
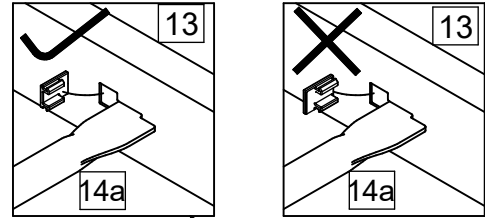

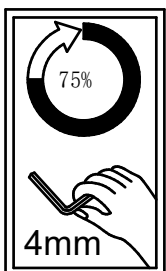
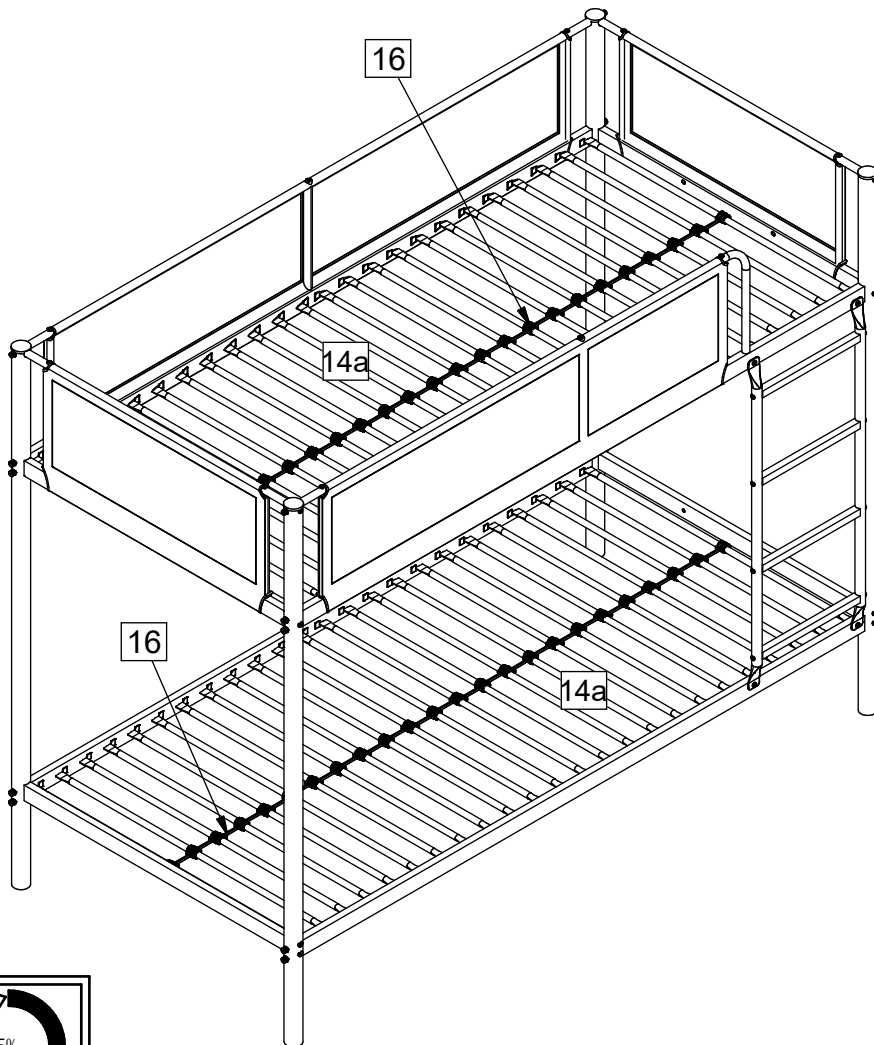
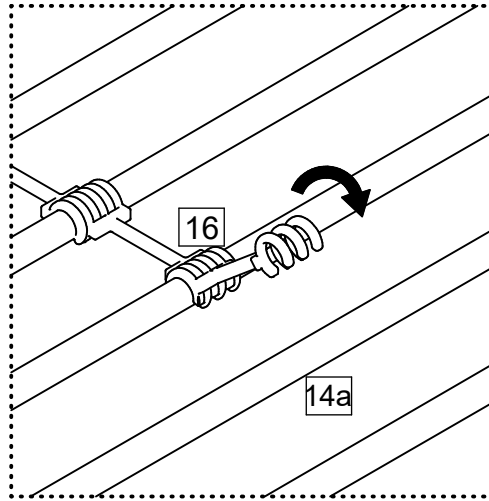

9

E



M6 X17MM

8 PCS

G

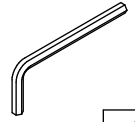

4 MM

1PC

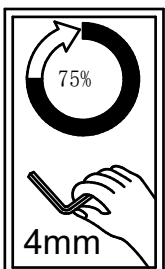
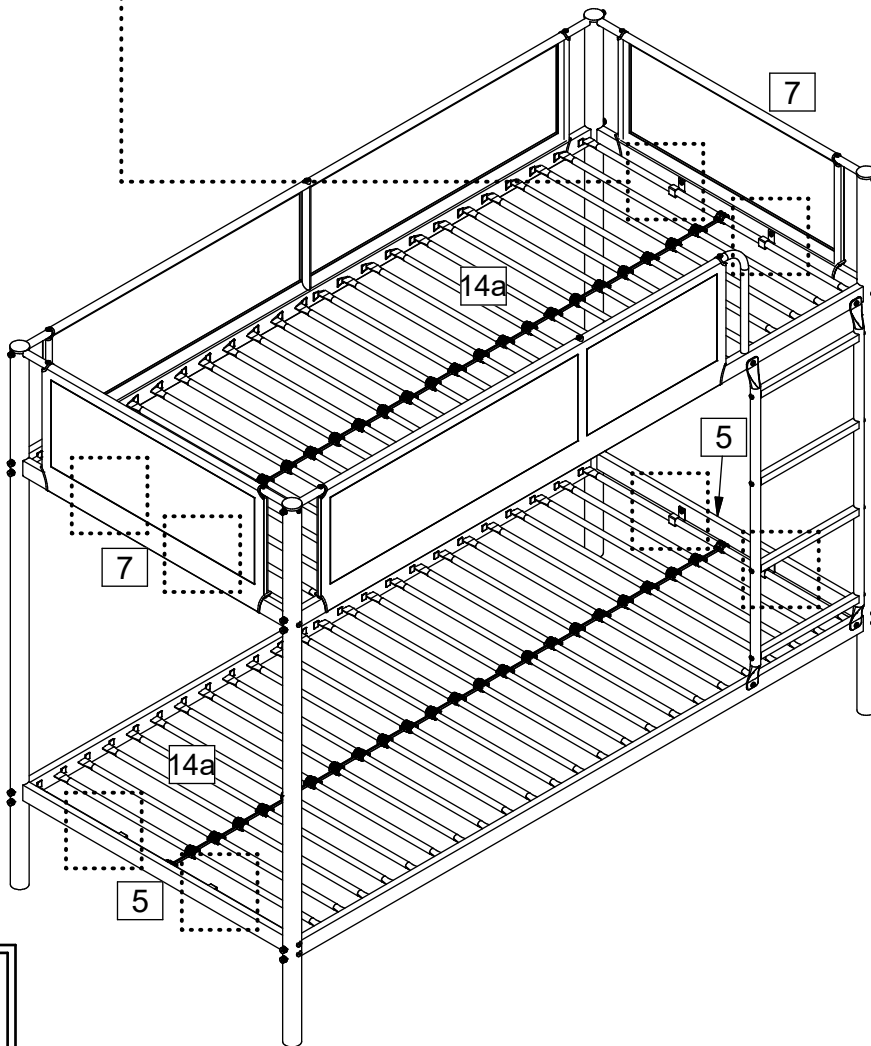
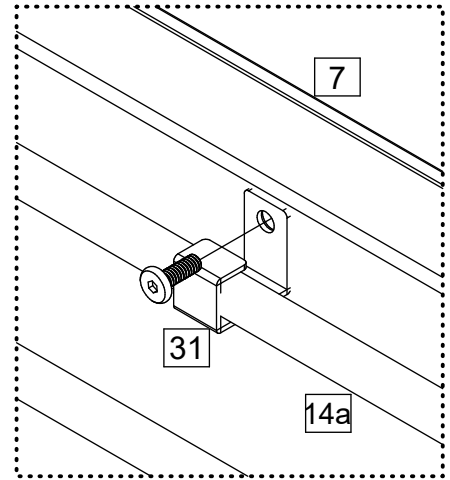
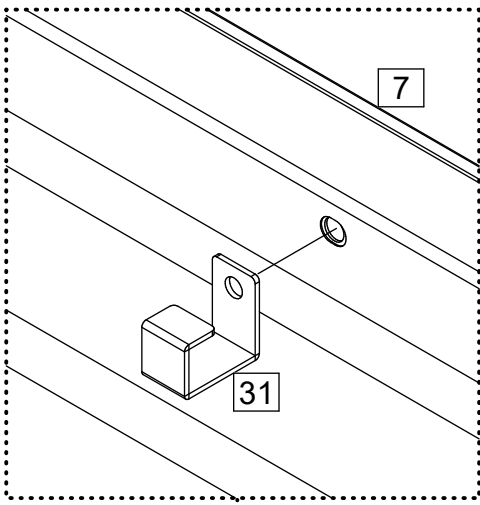

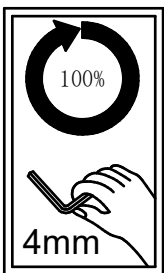
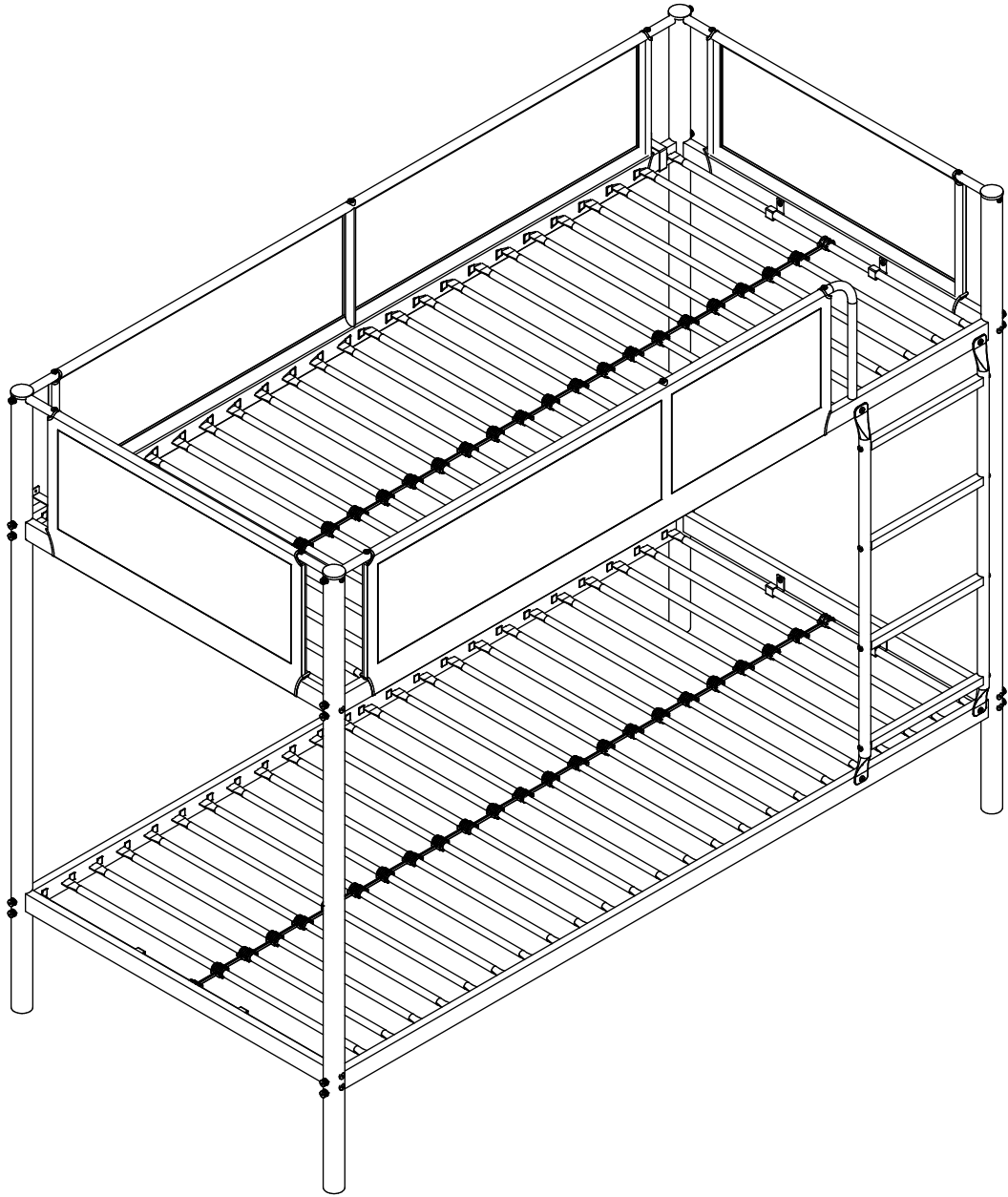

! FIXATIONS MURALES

IMPORTANT: for the wall device fixation kit, use screws and wallplugs adapted to the nature of the wall, in case of any doubt please contact your store.

IMPORTANT: pour la fixation murale, utiliser des vis et des chevilles adaptées à la nature du mur. En cas de doute, contacter votre magasin de bricolage.

Attention : bien veiller à respecter l'ensemble de la notice de montage.

Il existe une grande diversité de types de murs ou cloisons, c'est la raison pour laquelle nous ne pouvons vous fournir le type exact de fixation. Il est nécessaire d'identifier le type de paroi à laquelle vous allez fixer ce produit afin de vous procurer les fixations appropriées. Voici quelques exemples de fixations conseillées. Les vis et chevilles pour fixer le meuble au mur ou au plafond ne sont pas incluses. Choisissez des vis et chevilles adaptées au matériau de votre mur. En cas de doute, demandez à un vendeur spécialisé.

LES MURS PLEINS

CHEVILLE NYLON "FISCHER"

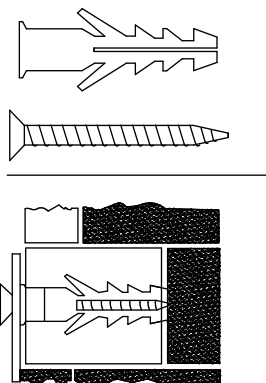

CHEVILLE D'ANCRAGE METAL

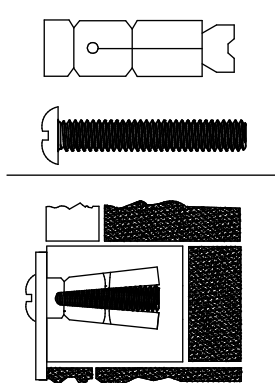

LES CLOISONS CREUSES

CHEVILLE D'ANCRAGE A AILETTES EN NYLON

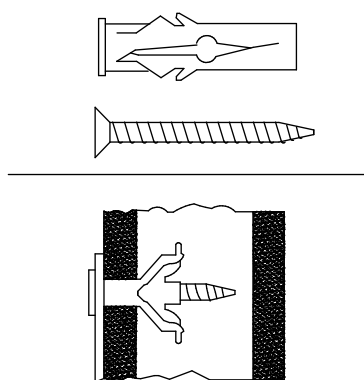

CHEVILLE METALLIQUE A EXPANSION

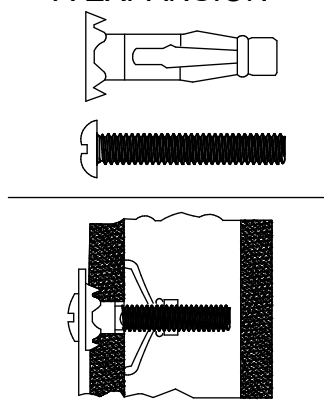

CHEVILLE "MOLLY"

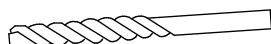
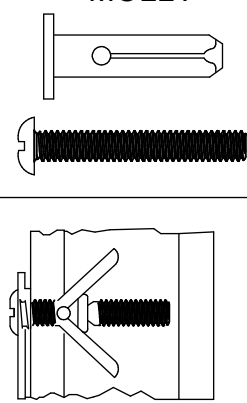

Utiliser une taille de foret adaptée à la quincaillerie utilisée et au type de mur 16

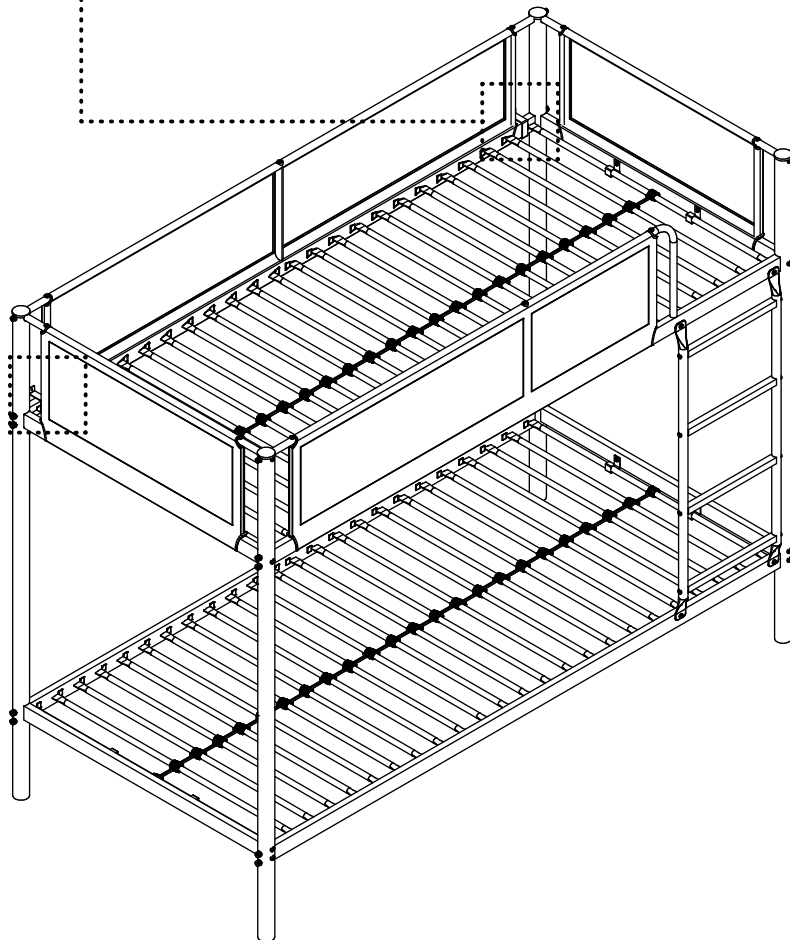
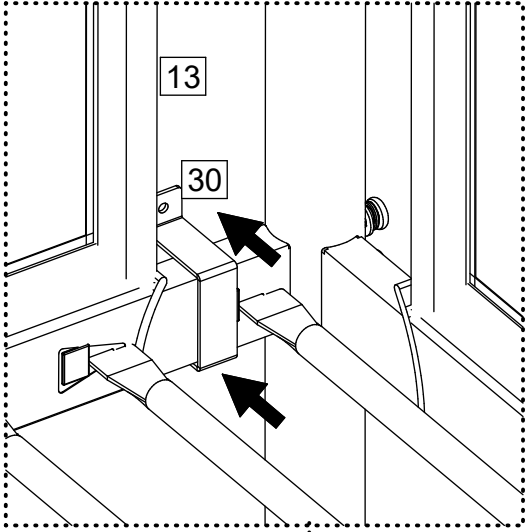

FRANCAIS

CONSEILS DE MONTAGE :

- 1 > BIEN ETUDIER LA NOTICE DE MONTAGE.
- 2 > REPEREZ LES PIECES CONSTITUANT VOTRE MEUBLE.
- 3 > REGROUPEZ ET CONTROLEZ LA QUINCAILLERIE.
- 4 > MUNISSEZ-VOUS DE L'OUTILLAGE NECESSAIRE.
- 5 > AMENAGEZ-VOUS UNE ZONE DE MONTAGE.
- 6 > PROCEDEZ AU MONTAGE.



NE JAMAIS FORCER LES ASSEMBLAGES. RESSERREZ LES VIS APRES QUELQUES TEMPS D'USAGE. GARDER VOTRE NOTICE DE MONTAGE, SI UNE PIECE VENAIT A MANQUER. ATTENTION AUX ZONES DE PINCEMENT LORS DU PLIAGE/DÉPLIAGE IMPORTANT, A CONSERVER POUR CONSULTATION ULTERIEURE: A LIRE ATTENTIVEMENT

CONSEILS D'ENTRETIEN :

- 1 > DÉPOUSSIÉREZ SOIGNEUSEMENT.
- 2 > HUMECTER UN CHIFFON DOUX ET PROPRE D'EAU LÉGÈREMENT SAVONNEUSE (OU DÉTERGENT).



- NE JAMAIS UTILISER DE PRODUITS ABRASIFS: POUDRE, LAINE D'ACIER, SOLVANTS.
- NE PAS MOUILLER TROP COPIEUSEMENT.

	PAPIER DECOR	SURFACES STRATIFIÉES	SURFACES LAQUÉES	BOIS VERNIS	TEXTILE CUIR
EAU SAVONNEUSE (SAVON NEUTRE)	<input type="radio"/>	<input type="radio"/>	<input type="radio"/>	<input type="radio"/>	<input type="radio"/>
EAU ADDITIONNÉE		<input type="radio"/>	<input type="radio"/>		
ENTRETIEN SPÉCIFIQUE FABRICANT					<input type="radio"/>

ENGLISH

ASSEMBLY ADVICE :

- 1 > CAREFULLY READ THE ASSEMBLY INSTRUCTION.
- 2 > IDENTIFY THE COMPONENTS OF THE FURNITURE.
- 3 > GROUP AND CHECK THE HARDWARE.
- 4 > USE THE REQUIRED TOOLS.
- 5 > CREATE AN ASSEMBLY ZONE.
- 6 > MAKE THE ASSEMBLY.



NEVER FORCE THE CONNECTIONS. RE-TIGHTEN THE SCREWS AFTER FEW DAYS. PLEASE RETAIN THE AI LEAFLET FOR FUTURE REFERENCE, THE AI CONTAINS INFORMATION WHEN CLAIMING FOR MISSING PARTS.

CLEANING ADVICE:

- 1 > CAREFULLY REMOVE THE DUST.
- 2 > USE A SOFT, CLEAN DAMP CLOTH WITH SOAPY WATER.



NEVER USE ABRASIVE PRODUCTS OR SOLVENTS. DO NOT APPLY EXCESSIVE PRESSURE WHEN USING THE DAMP CLOTH.

	PAPER DECOR	LAMINATED SURFACES	LACQUERED SURFACE	VARNISHED WOOD	LEATHER TEXTILE
SOAPY WATER (NEUTRAL SOAP)	<input type="radio"/>	<input type="radio"/>	<input type="radio"/>	<input type="radio"/>	<input type="radio"/>
WATER WITH DETERGENT		<input type="radio"/>	<input type="radio"/>		
SPECIFIC SUPPLIER CLEANING					<input type="radio"/>

FR - IMPORTANT -A CONSERVER POUR REFERENCE ULTERIEURE - LIRE ATTENTIVEMENT

Ce produit est destiné à un usage domestique. Veuillez à le positionner de façon stable avant utilisation. A MONTER SOI-MEME.

EN - IMPORTANT, KEEP FOR FUTURE REFERENCE: READ CAREFULLY

This product is for domestic use. Make sure the position is stable before use. Product should be assembly by users.