

B (3 : 5)

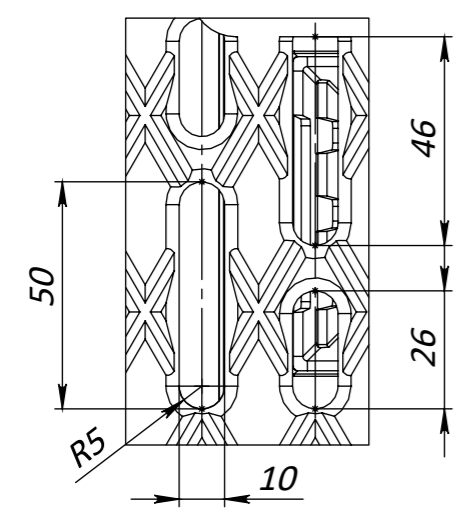

1. Deviation of the actual weight of the nominal can be up to 8%
2. Area of water intake slots 139.7 sq cm

UNLESS OTHERWISE SPECIFIED: DIMENSIONS ARE IN MILLIMETERS SURFACE FINISH: TOLERANCES: ISO 2768-c LINEAR: ANGULAR:			FINISH:		DO NOT SCALE DRAWING		REVISION			
					TITLE: Plastic sand trap Easy DN100 H250 with basket and plastic slotted grate A15					
					Load class: A15					
					ARTICLE: 0888081				A3	
					WEIGHT: 1,636 kg		SCALE: 1:5		SHEET 1 OF 1	
DRAWN: L/L		CHK'D: LMK		DATE: 14.10.22		NAME:		SIGNATURE:		
APPV'D:		MFG:		Q.A:		MATERIAL:				