

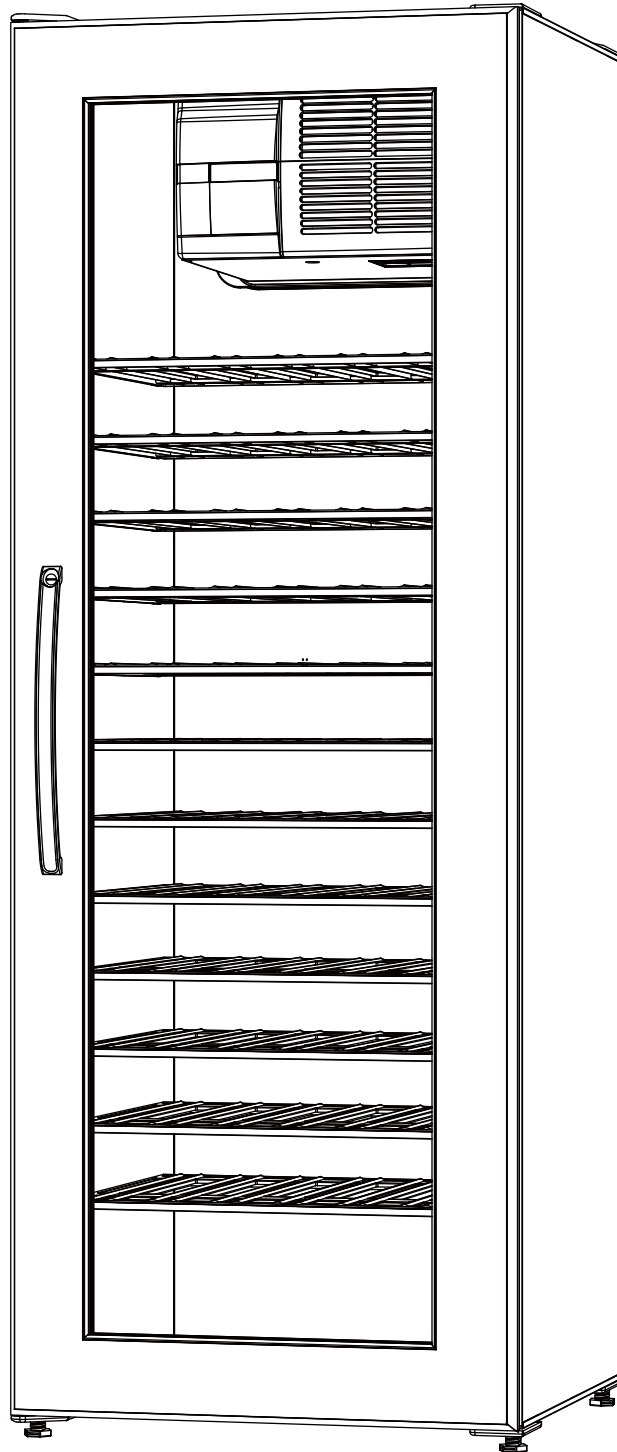

WineKoolR™

120



Read the "USE and CARE" guide before you start !

LOCATING YOUR WINE CELLAR

Provide 2 1/2" minimum clearance for both sides and back; keep the top clear.

Never locate your wine cellar outdoors or in an area with extremes of temperature and humidity. These units must be placed/located/operated in air-conditioned environments which do not "trap" the warm air exhaust.

Temperatures in surrounding area must not exceed 80 °F (25 °C) with relative humidity levels not to exceed 70% R.H.. Never set your temperatures below default (57°F) whenever ambient conditions are warm (above 75°F) or humid (above 50%R.H.).

Outlet power must be a DEDICATED separately fused, grounded, 15 Amp 110 - 120 V line or 7.5 Amp - for 240 V models (CHECK BOX OR SERIAL NUMBER LABEL ON UNIT FOR YOUR LINE VOLTAGE REQUIREMENTS).

You must monitor your unit DAILY. If unit is in "Alarm", unplug the unit immediately.

KoolR Products™ will not be liable or responsible for incidental or consequential damages. (See Warranty).

Place unit in a clean area and allow access to the exterior surfaces for periodic vacuuming of the condensor coil. (See troubleshooting for details).

Clean using a damp cloth and **no detergents or polishes** under any circumstances.

Always remove all bottles before relocating your wine cellar.

AREA FOR ASSEMBLING YOUR WINE CELLAR

Choose a clear 12' by 8' area with a level floor. Place soft material underneath (carpet) to avoid scratching!

TOOLS

Rubber mallet, Allen key (included), Adjustable wrench, Phillips screwdriver, Drill.

Helper is needed.

TEST THE COOLING UNIT

Plug it in on a table top, to verify that controls and display are functional, and that the unit is producing cool air after a few minutes of operation.

Note that the electronic controller has a one-minute safety delay between initial plug-in and start-up of the compressor.

BEFORE YOU START !

Fill out the **WARRANTY REGISTRATION FORM**. You will find the serial number for the form located on the **LEFT SIDE** of the unit or on the light cord.

HARDWARE

HINGES

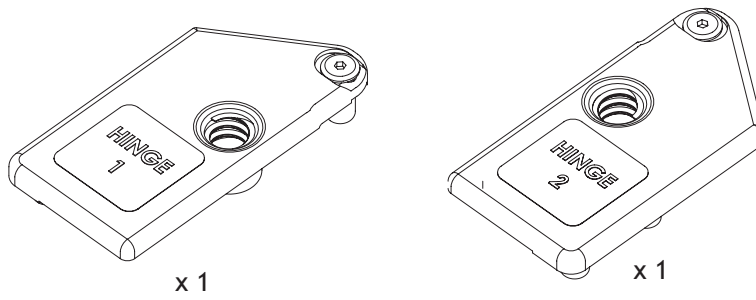

CONNECTOR PLATES

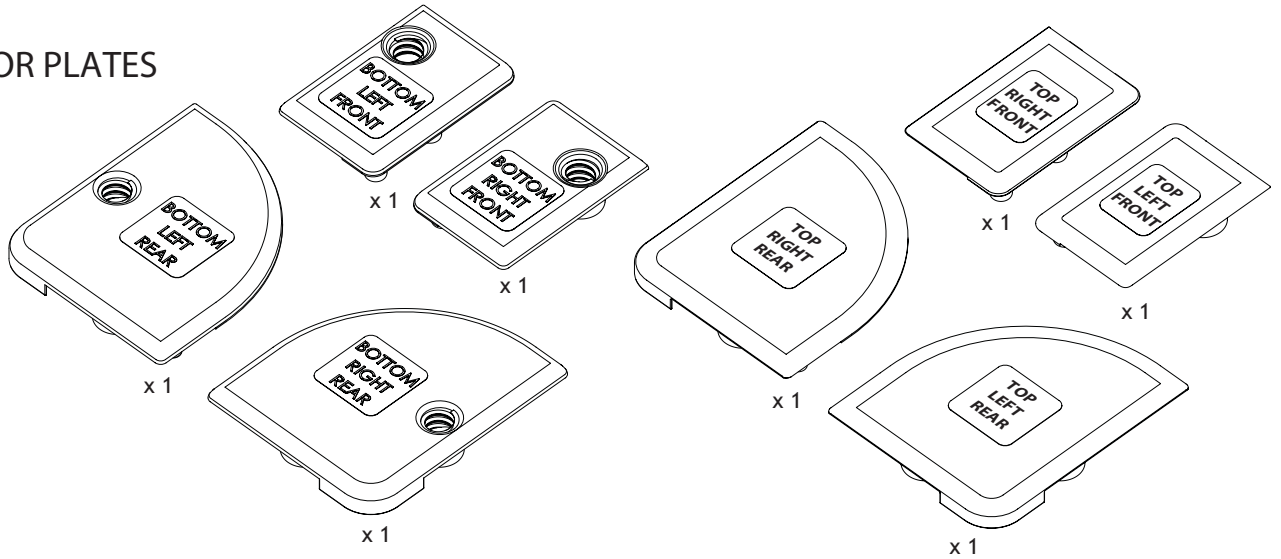

A



Bottom Hinge Washer
x 1

B

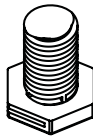

Legs
x 4

C

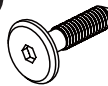

Cooling Unit Bolts
in cooling unit box
x 2

D



Allen Key
in cooling unit box
x 1

E

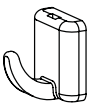

Hooks
x 2

F

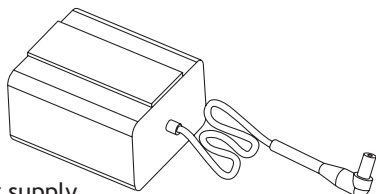

Power supply
x 1

G

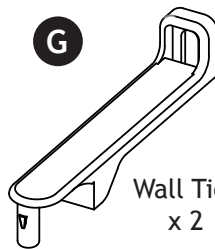

Wall Ties
x 2

H

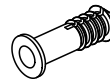

Anchors
x 2

I

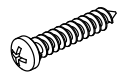

Screws
x 2

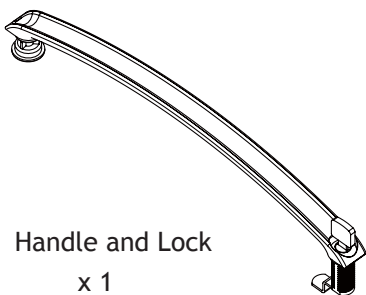

Handle and Lock
x 1

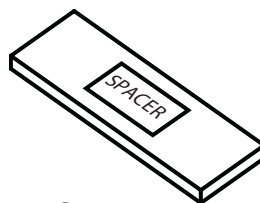

Spacer
x 1

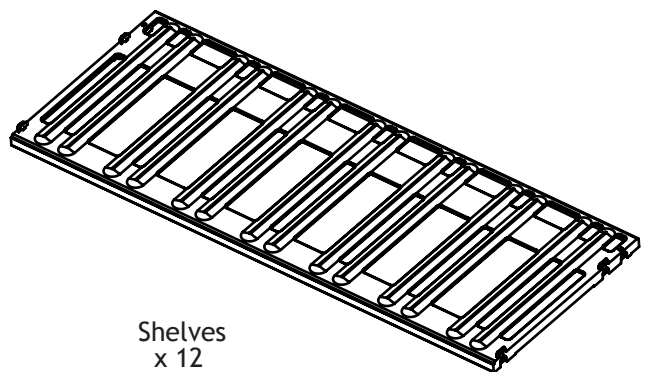

Shelves
x 12

1

INSERT SIDES

LAY BACK ON FLOOR AGAINST WALL

GET HELPER TO GUIDE IN SIDES

USING RUBBER MALLET TAP LEFT AND RIGHT SIDES INTO PLACE

 DO NOT LIFT SIDE WHEN SLIDING IN

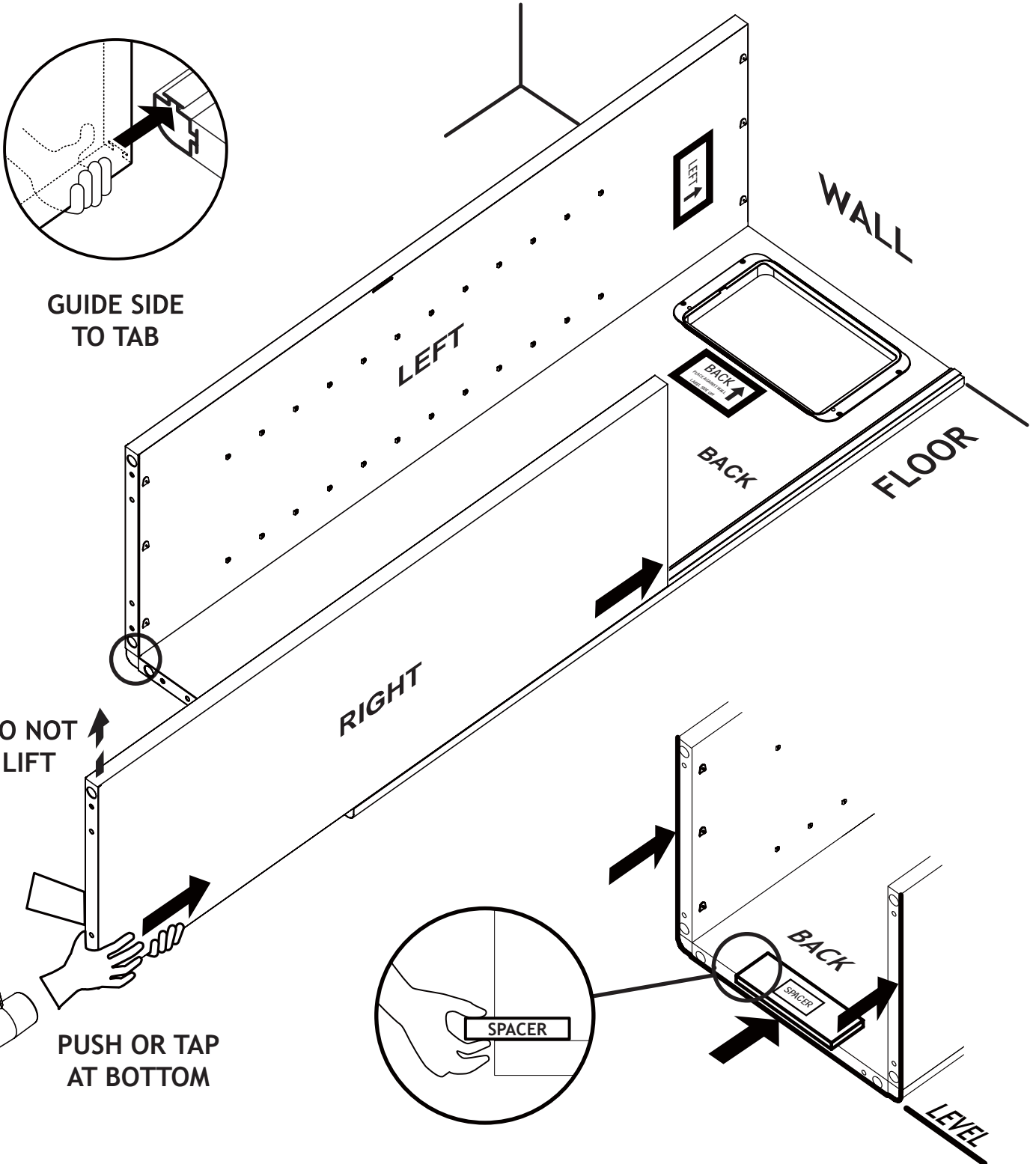

GUIDE SIDE TO TAB

 DO NOT LIFT

PUSH OR TAP AT BOTTOM

PLACE SPACER ON BACK OVER HANG SPACER FROM EDGE

2

INSERT BOTTOM

(HELPER NEEDED)

1. STRETCH SIDES
TO INSERT BOTTOM

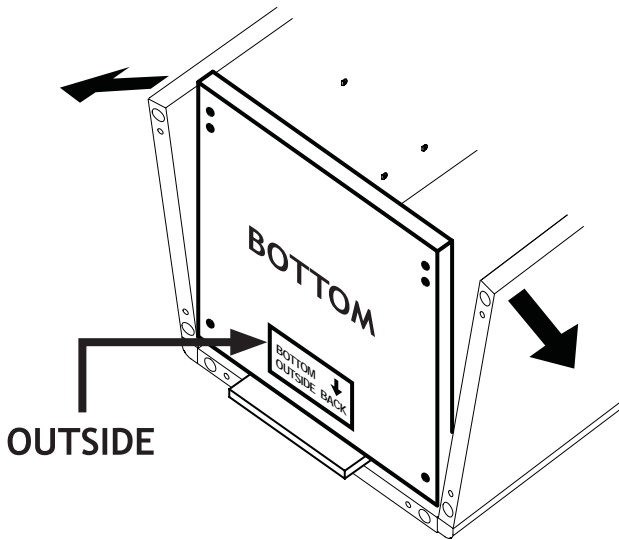

3. PRESS IN SIDES FULLY

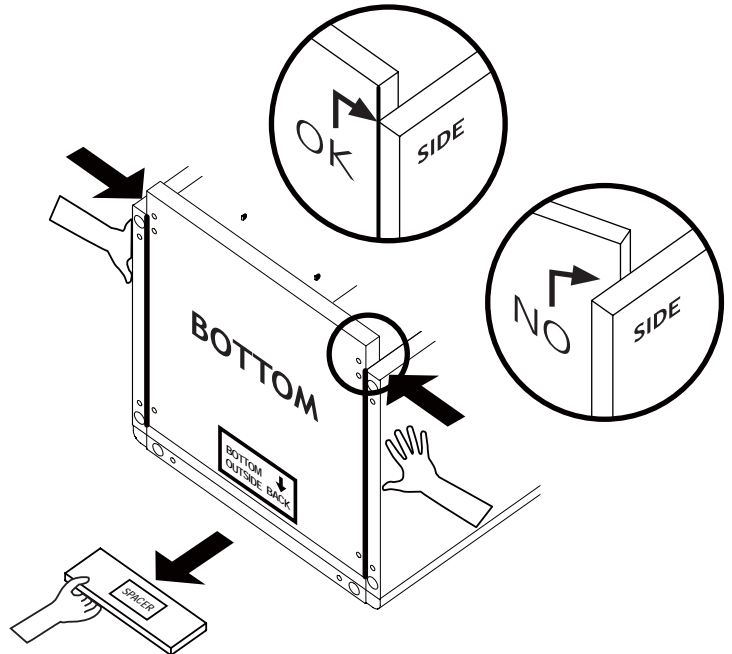

2. REST BOTTOM ON SPACER

4. PULL OUT SPACER

5. KEEP SIDES PRESSED IN AND
PUSH DOWN BOTTOM FULLY

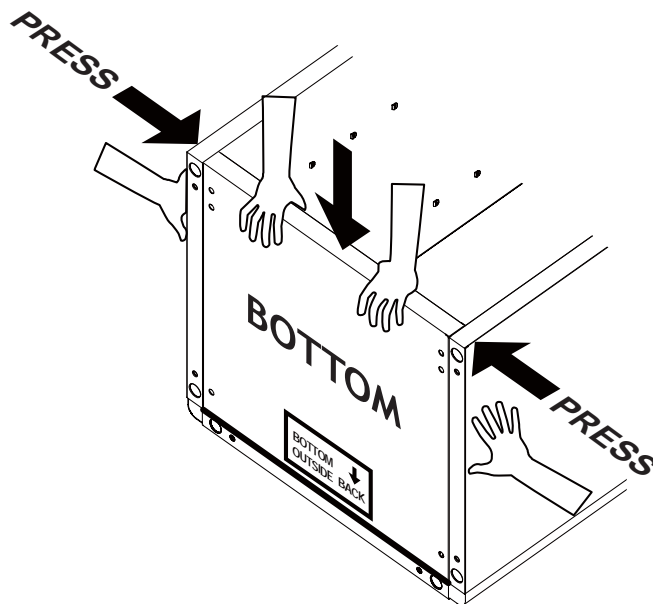

3

INSTALL BOTTOM CONNECTOR PLATES



WARNING! Connector plates can be removed **ONLY** as described on page 14.

HAND PRESS IN BOTTOM REAR CONNECTOR PLATES

CHOOSE WHICH SIDE TO PLACE THE HINGE, RIGHT OR LEFT

CHOOSE HINGE POSITION

HINGE ON RIGHT

HINGE ON LEFT

INSERT: HINGE 1

INSERT: HINGE 2

BOTTOM LEFT FRONT CONNECTOR

BOTTOM RIGHT FRONT CONNECTOR

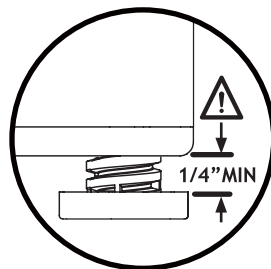
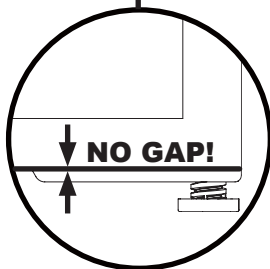
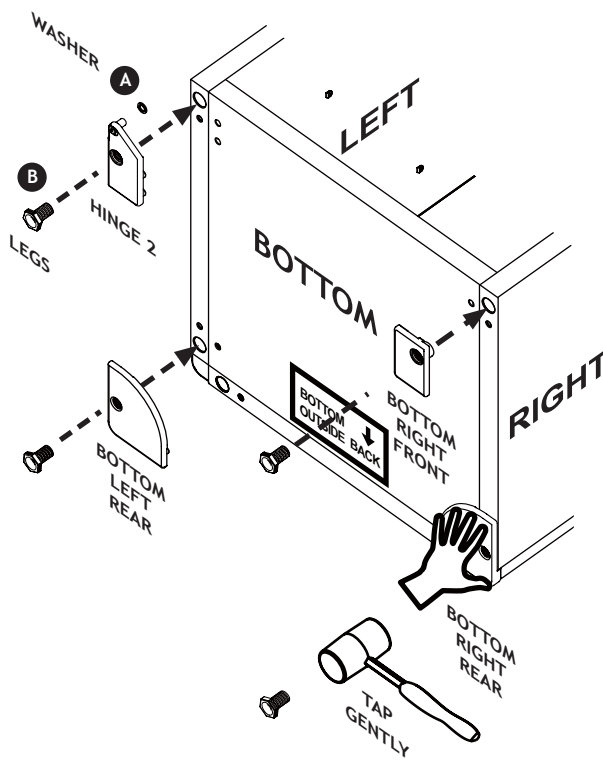
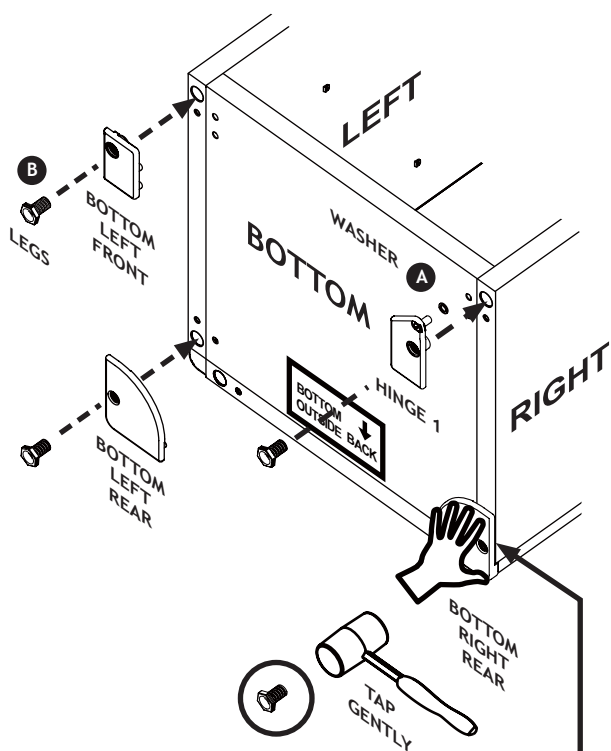

TAP IN CONNECTORS TIGHTLY (NO GAP) WITH CLOSED HAND OR RUBBER MALLET

SCREW IN ALL LEGS (B)



LEAVE MIN 1/4" SPACING ON ALL LEGS

4

INSTALL TOP AND TOP CONNECTOR PLATES



WARNING! HINGES can be removed **ONLY** as described on page 14.

REPEAT STEP 2 ON PAGE 5 FOR TOP PANEL

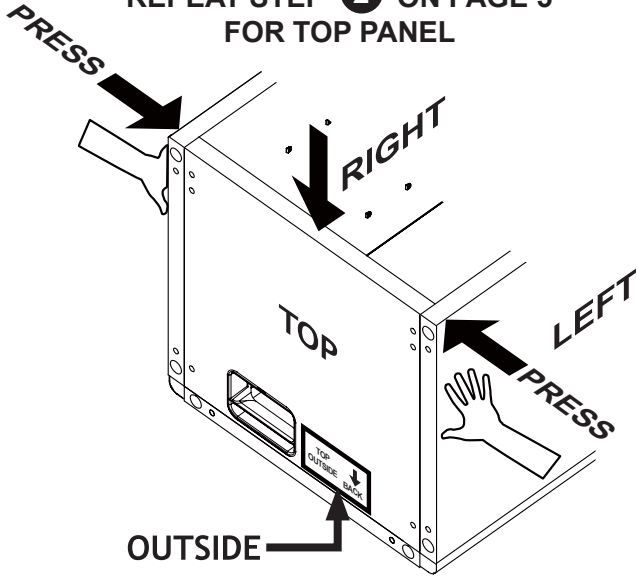

HAND PRESS IN TOP REAR CONNECTOR PLATES

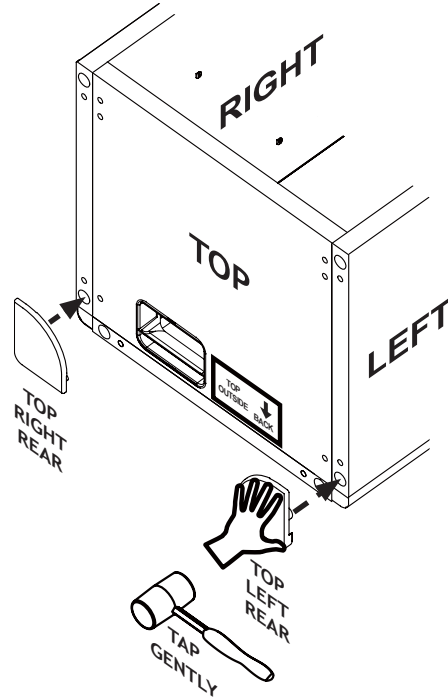

DO NOT INSTALL HINGE YET!



BASED ON YOUR HINGE CHOICE IN STEP 3

HINGE ON RIGHT

INSERT TOP LEFT FRONT CONNECTOR

HINGE ON LEFT

INSERT TOP RIGHT FRONT CONNECTOR

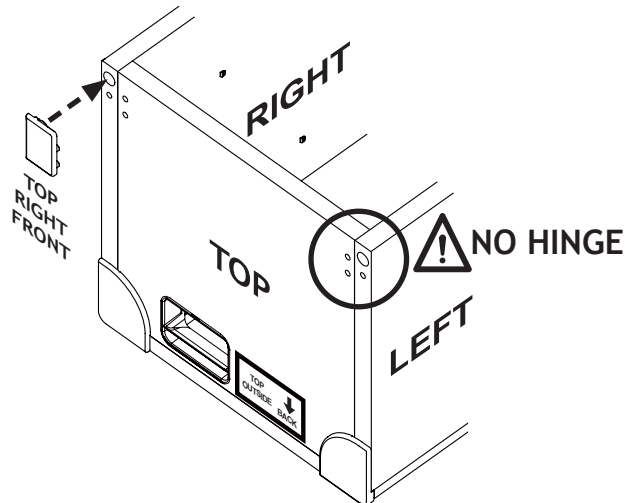
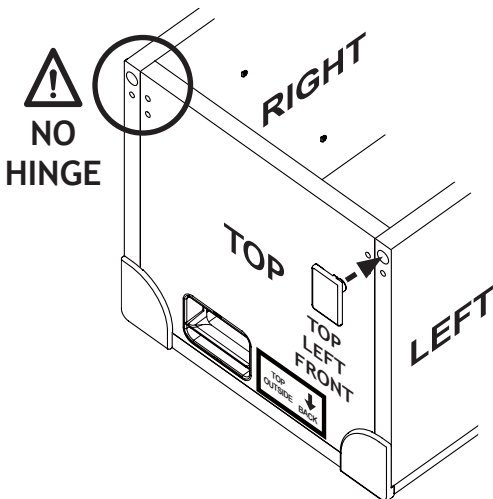

TAP IN CONNECTORS TIGHTLY (NO GAP) WITH CLOSED HAND OR RUBBER Mallet (SAVE REMAINING CONNECTOR PLATES IF YOU DECIDE TO CHANGE HINGE SIDE)

5

INSTALL DOOR

PLACE WASHER FIRST
PLACE DOOR ON CABINET
SLIDE DOOR ON TO BOTTOM HINGE

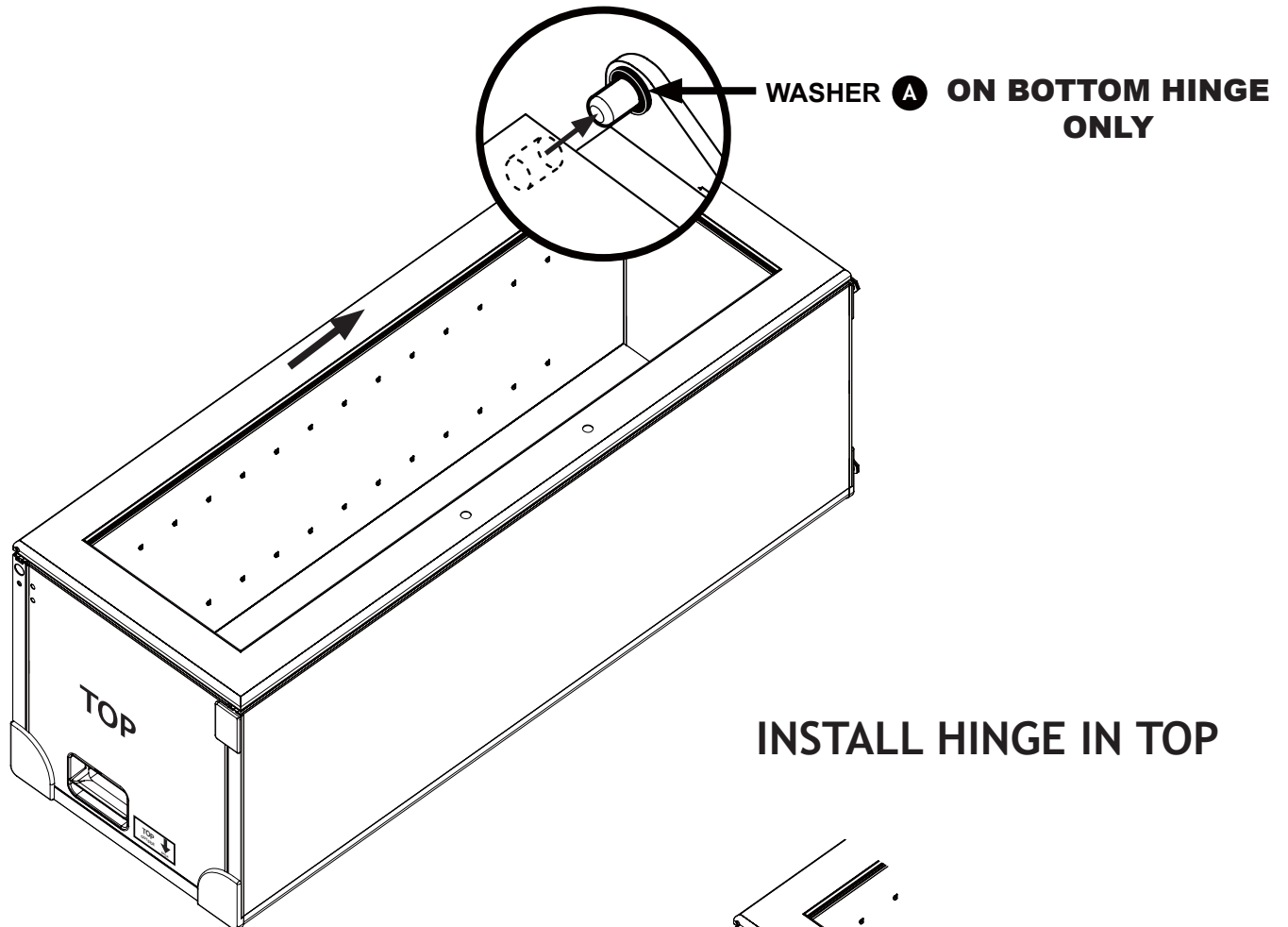

INSTALL HINGE IN TOP

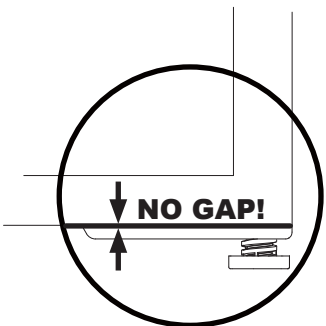
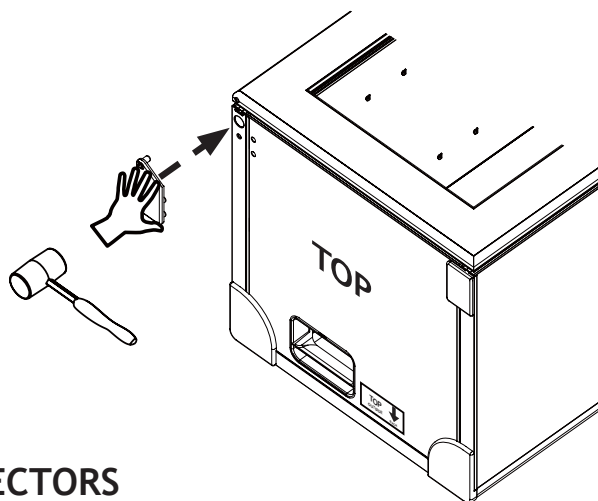

CHECK ALL CONNECTORS
AND HINGES !

STAND THE UNIT UP NOW!

NOTE: Door is made of a very tough PLEXIGLAS, but it can be scratched.
Handle and clean with care!

6

INSTALL SHELVES

⚠ (HELPER NEEDED TO HOLD CABINET STEADY)

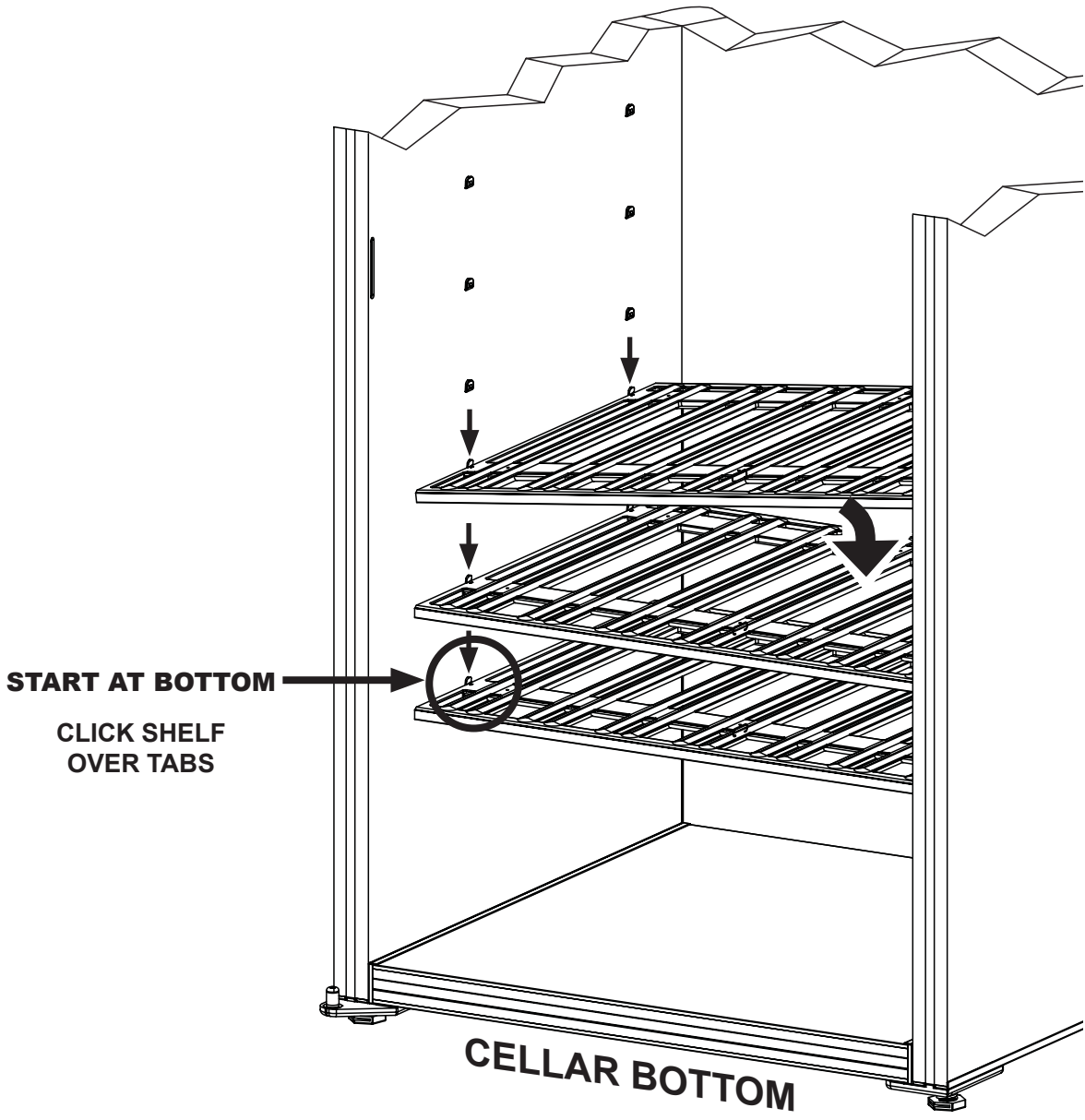
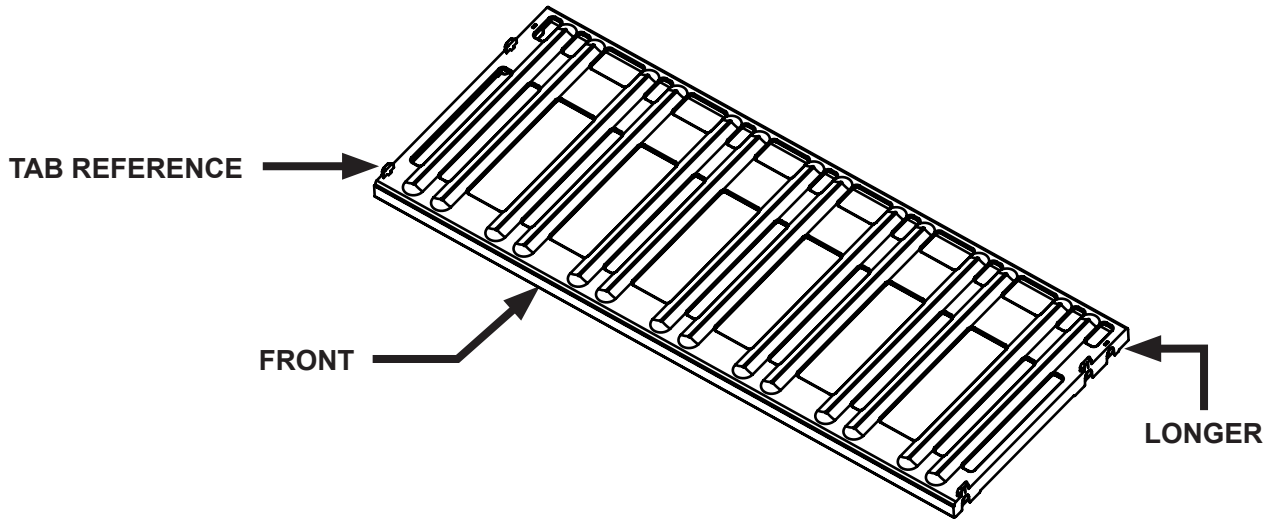

7

PLACE COOLING UNIT IN CABINET

 (HELPER NEEDED TO HOLD CABINET STEADY)

KEEP UNIT LEVEL

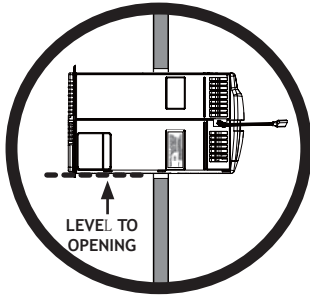

DO NOT!!!

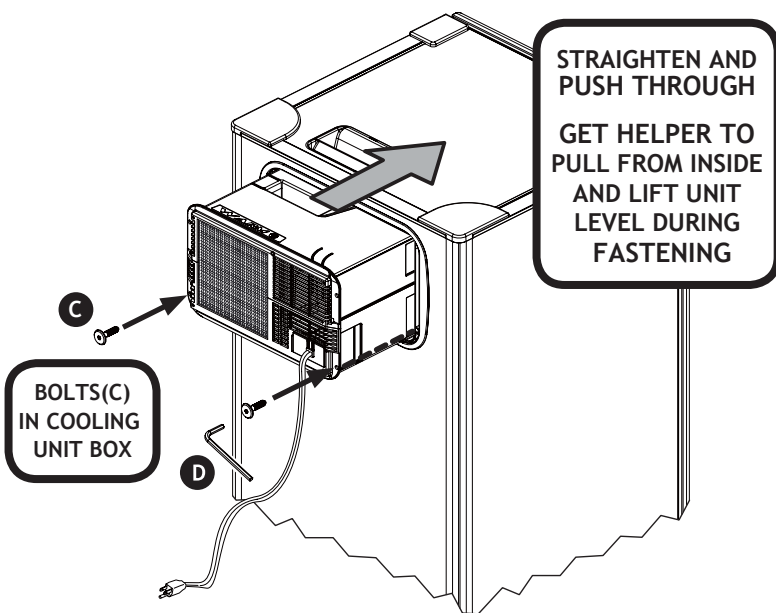
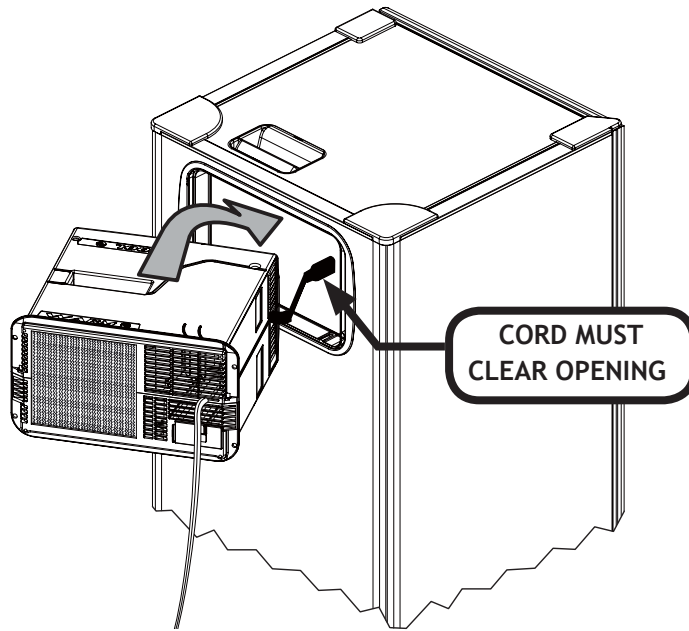
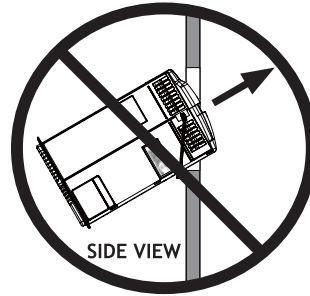

COOLING UNIT MUST SEAL !
CHECK AFTER TIGHTENING !!!

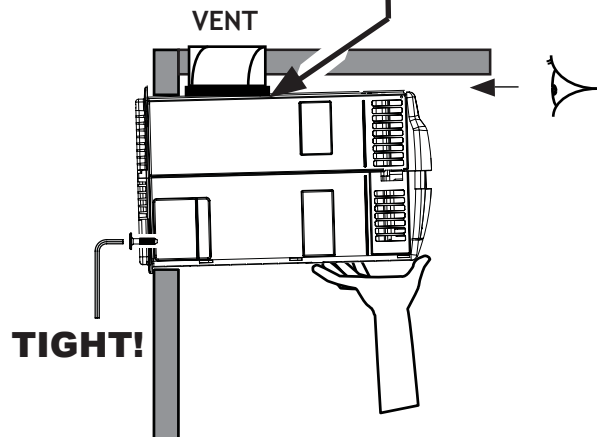

KEEP UNIT LIFTED
UP INSIDE
DURING FASTENING!

8

CONNECT LIGHT AND HOOKS

LED LIGHT : WARM WHITE GLOW FOR NATURAL LIGHTING, NO HEAT, ENERGY EFFICIENT

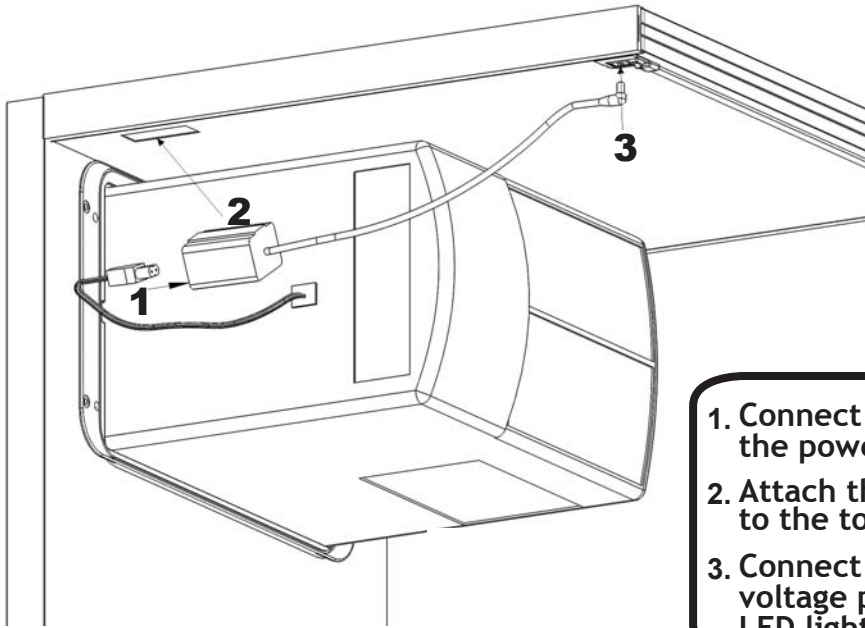

1. Connect the power to the power supply
2. Attach the power supply to the top panel
3. Connect the round low voltage plug to the LED light

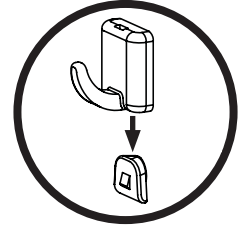

USE HOOK TO HANG WINE LISTS OR BOTTLE OPENER

INSTALL HANDLE

9

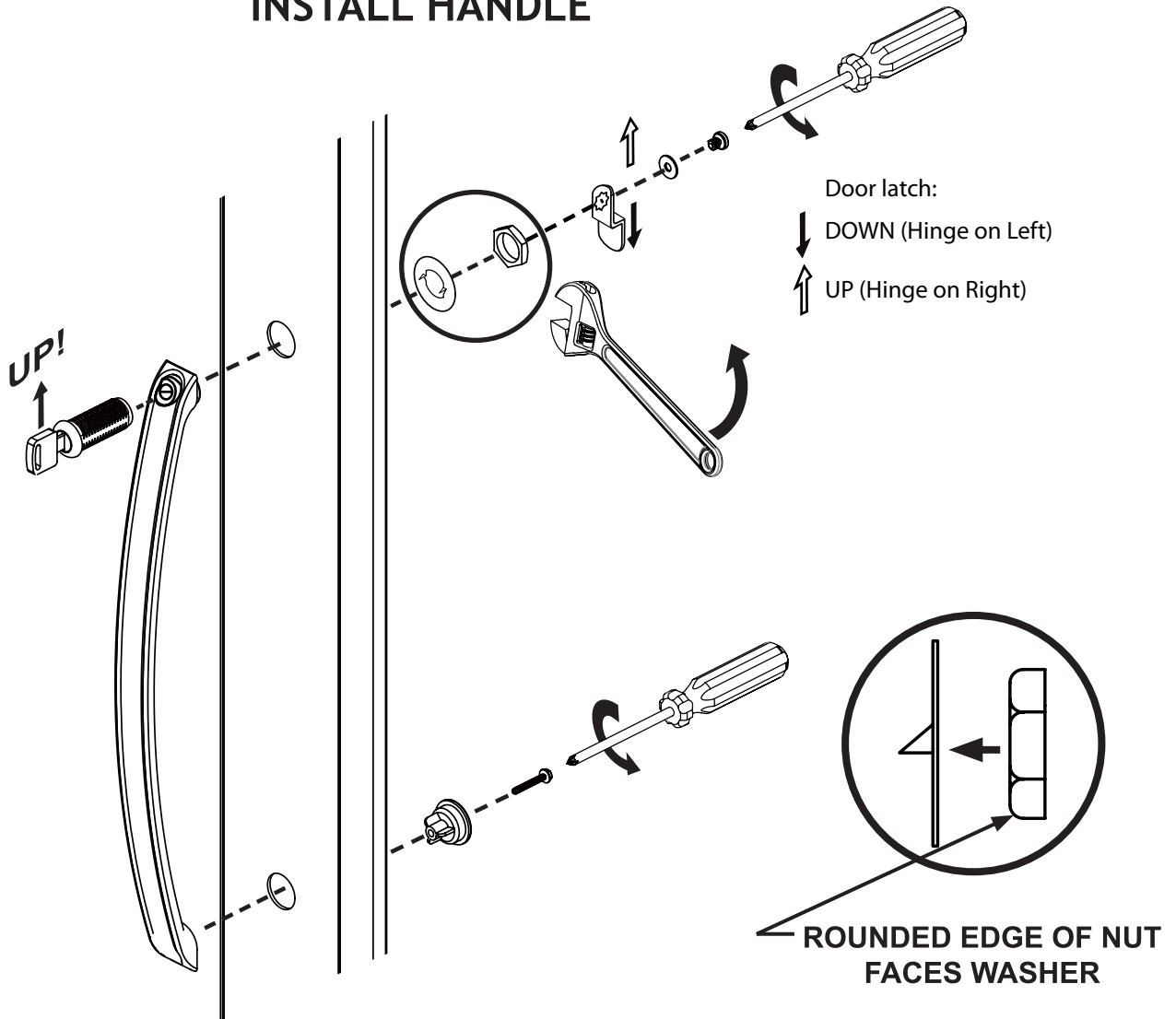

10

LEVEL CELLAR

LEVEL DOOR

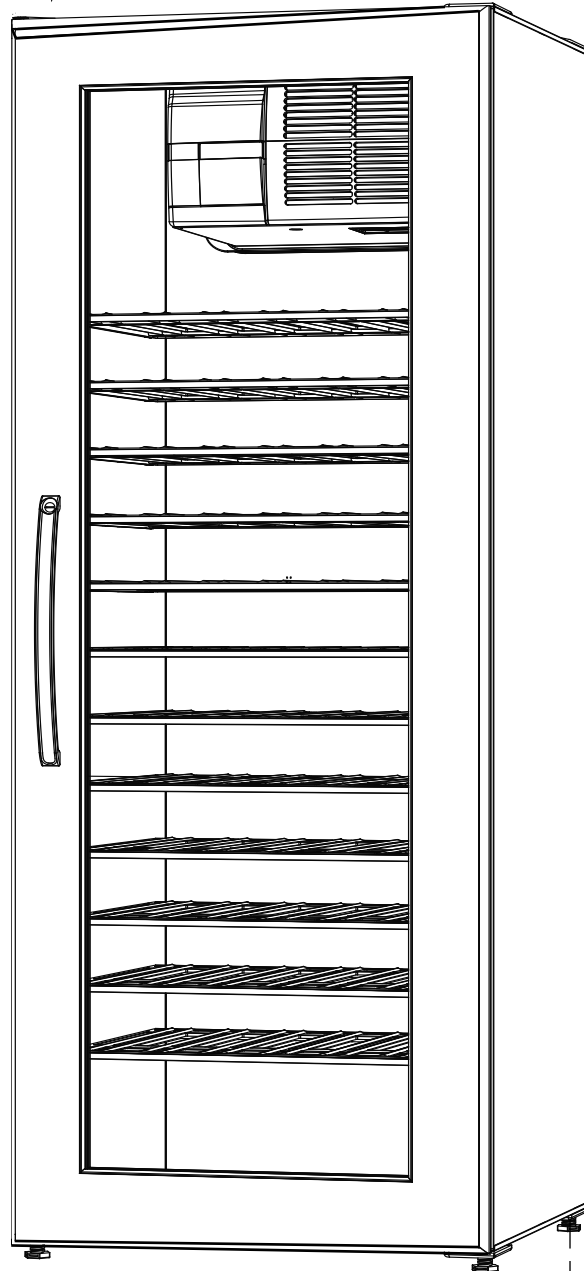

ADJUST REAR LEG TO LEVEL DOOR

HINGES ARE PRE-SET
ADJUSTMENTS SHOULD NOT BE REQUIRED

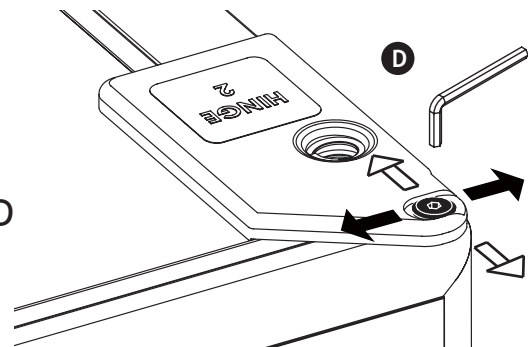

11

BRACE TO WALL



WARNING: RISK OF INJURY !
IF CABINET IS NOT FULLY LOADED IN THE BOTTOM IT CAN BE TOP HEAVY.
TO AVOID INJURY OR DAMAGE ALWAYS BRACE TO WALL !

WALL MATERIALS VARY, USE APPROPRIATE ANCHORS FOR YOUR APPLICATION.
FOR ADVICE ON SUITABLE SCREW SYSTEMS, CONTACT YOUR SPECIALIZED DEALER.

INSERT WALL TIES INTO REAR CONNECTOR PLATE HOLES



(DO NOT PRESS IN FULLY)

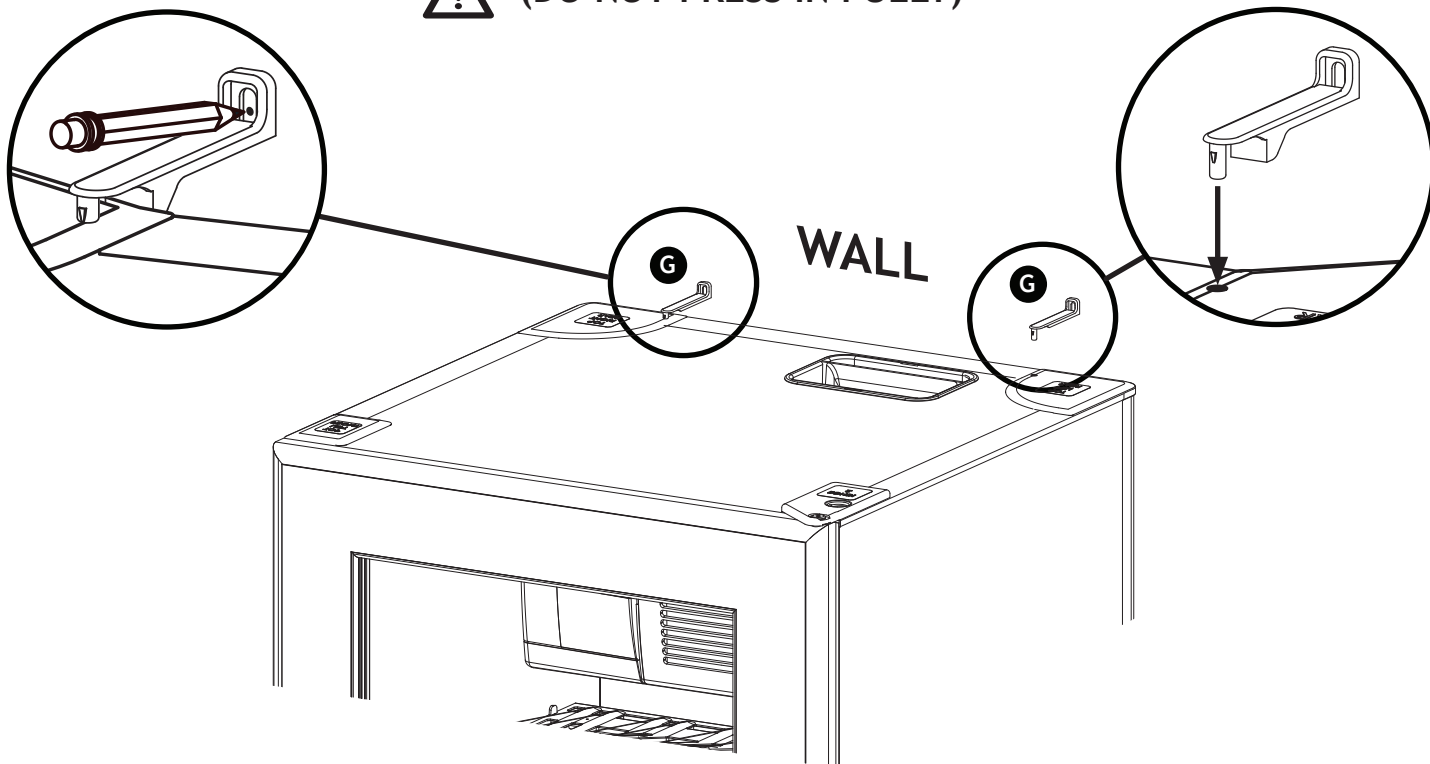

DRILL USING 1/4" (6 - 6.5 mm) DRILL BIT AND TAP IN ANCHORS **H**

PRESS IN FULLY WALL TIES INTO REAR CONNECTOR PLATES AND SCREW IN SCREWS **I**

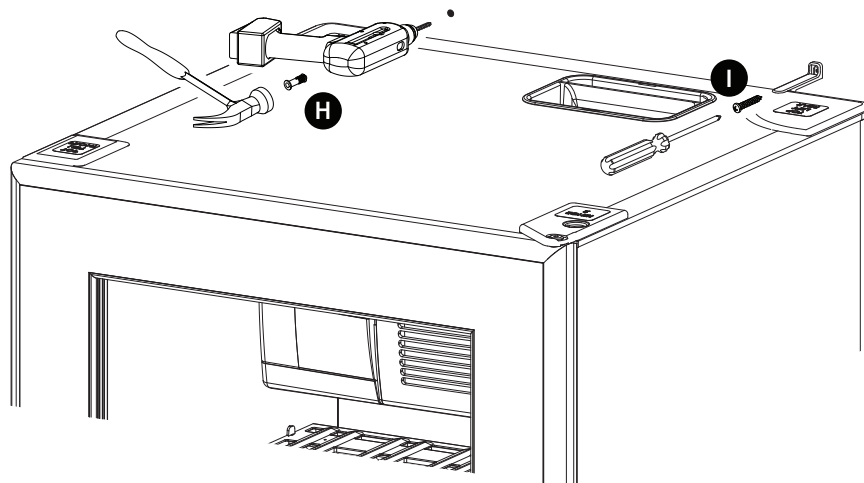



**NEVER MOVE LOADED CABINET ! EMPTY FIRST !
PLACE DOLLY AT BACK !**

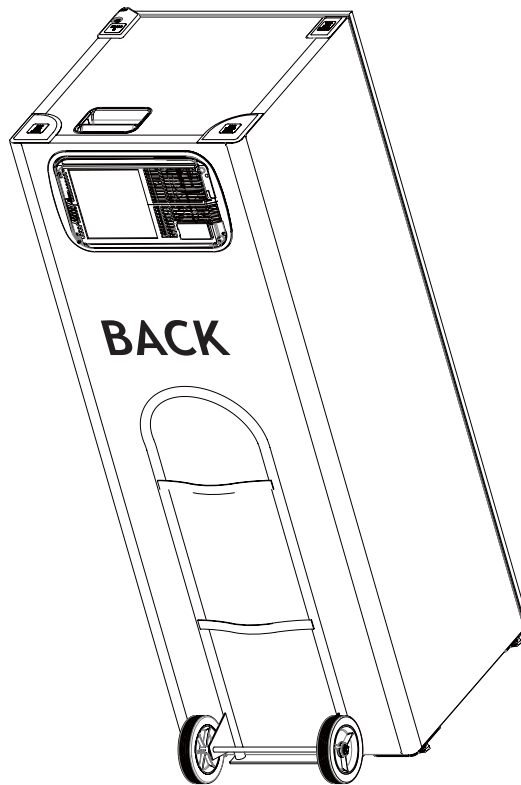

DISASSEMBLY

REMOVE COOLING UNIT AND SHELVES
LAY CELLAR DOWN
FULLY TIGHTEN LEGS
PRY OFF ALL CONNECTOR PLATES WITH FLAT SCREWDRIVER

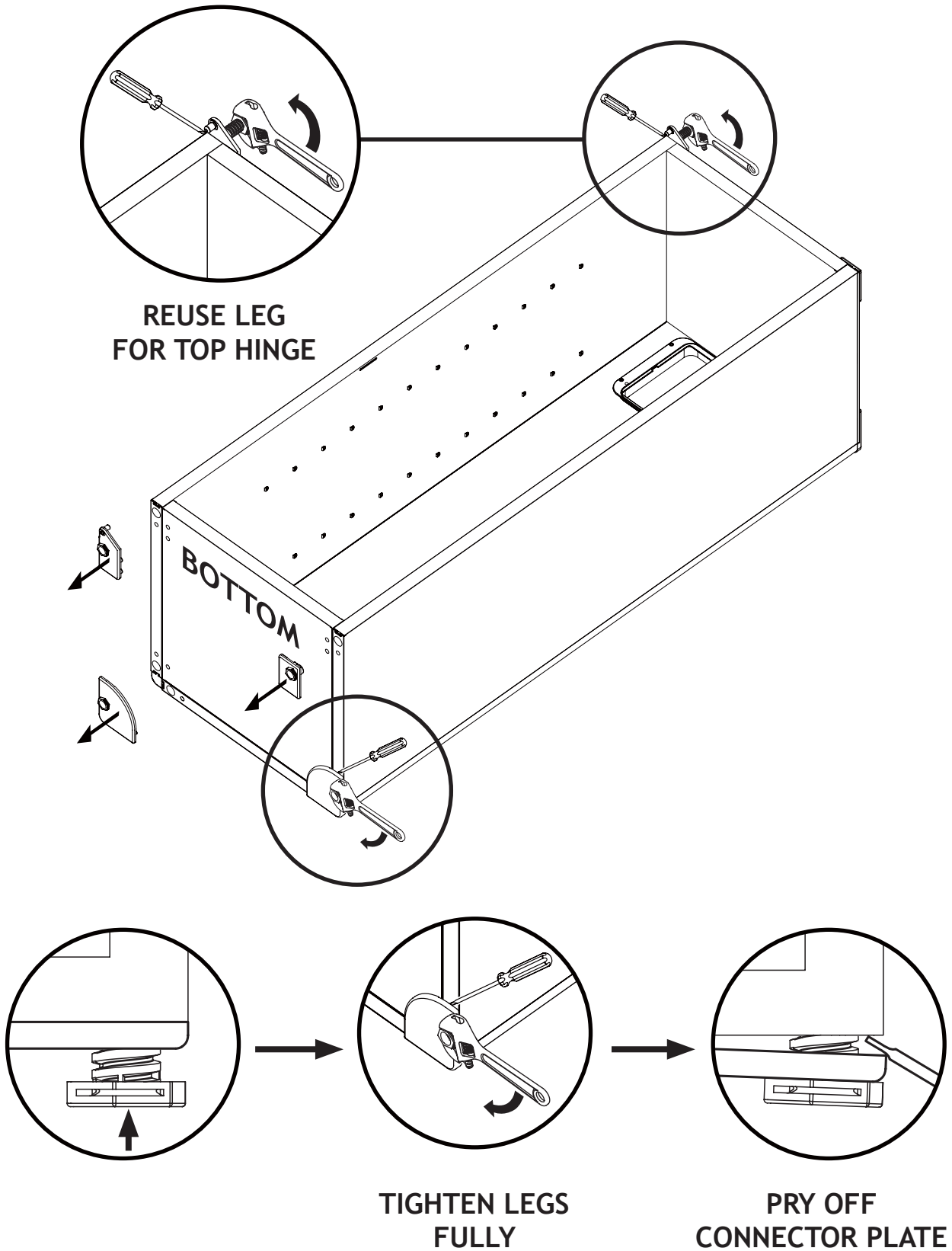

CONTROLS : PLUG IT IN (wait one minute) and ENJOY!

FEATURES:

- Default SET temperature 57° F/14° C (ideal for wine storage).
- Calibration option of the temperature sensor.
- Display of actual temperature by request.
- SET temperature range 53°F-64°F.
- Digital temperature sensor.
- Dual display F°/C°.
- Settings are stored in memory for power failures.
- Pre-programmed software will establish the quietest most efficient operation.

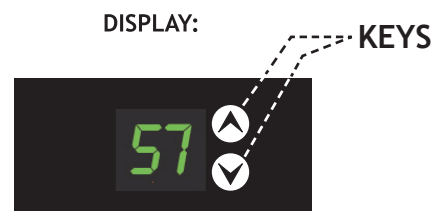

OPERATION:

- The display will show the detected temperature until the temperature falls within $\pm 3^\circ$ of the SET POINT (normal cooling range).
- If the temperature is above the default 57° F + 1° or other preset value, after a **delay of 1 minute** the fan will start, followed by the compressor within the next minute.
- The unit will cycle ON/OFF based on the temperature reading. Fan speeds are automatically set by the controller to achieve optimum performance.
- Minimum ON and OFF cycle times are imposed by software, to prevent "short cycling".

CONTROLLER OPERATION	ACTION	DISPLAY EXAMPLE	
		BEFORE	AFTER
TO DISPLAY:	Actual temperature: PRESS \blacktriangle	57°	56°
	SET temperature: PRESS \blacktriangledown	70°	57°
TO MODIFY SET TEMPERATURE (range is 53-64°F):	PRESS and RELEASE \blacktriangledown	57°	57°
	To increase: PRESS \blacktriangle once per degree	57°	58°
	To decrease: PRESS \blacktriangledown once per degree	57°	56°
	The new value will be memorized and the controller will reset automatically.		
TO CHANGE FROM °F to °C: or °C to °F	PRESS and HOLD \blacktriangledown until buzzer sounds in 5 seconds	57°	14°
	The new value will be memorized and the controller will reset automatically.		
TO CALIBRATE:	PRESS and HOLD \blacktriangledown while holding PRESS \blacktriangle and RELEASE BOTH QUICKLY	57°	57°
	Wait 5 seconds	57°	F0
	USE \blacktriangle for each degree of positive offset	F0	F1
	\blacktriangledown for each degree of negative offset	F0	-1
NOTE: A negative offset \blacktriangledown will result in a warmer cabinet and a positive offset \blacktriangle will result in a cooler cabinet. The new value will be memorized and the controller will reset automatically.			

SAFETY FEATURES:

- ALARM:**
- If the temperature exceeds 72° F the unit will shut down, a sound warning will start and the display will blink alternating with the temperature reading.
 - This function is disabled in the first 4 hours "Cool Down" period or after any reset for another 4 hours.
 - The unit will restart and continue the cooling and cycling if the temperature falls below 72° F.

AL

- TO RESET:** - Unplug and re plug the unit after 10 minutes.

MAXIMUM CAPACITIES AND LOADING TIPS

Maximum capacities and sample loading arrangements for **WineKoolR™** wine cellars are illustrated below. Standard Burgundy and Bordeaux bottles are best arranged with necks facing out; some taller bottles may need to be arranged neck to neck. Never stack bottles more than two rows high on a shelf; all shelves must be installed as directed. Avoid placing bottles directly in front of the cooling unit's circulating fan for more uniform temperature in cabinet.

MODEL 120

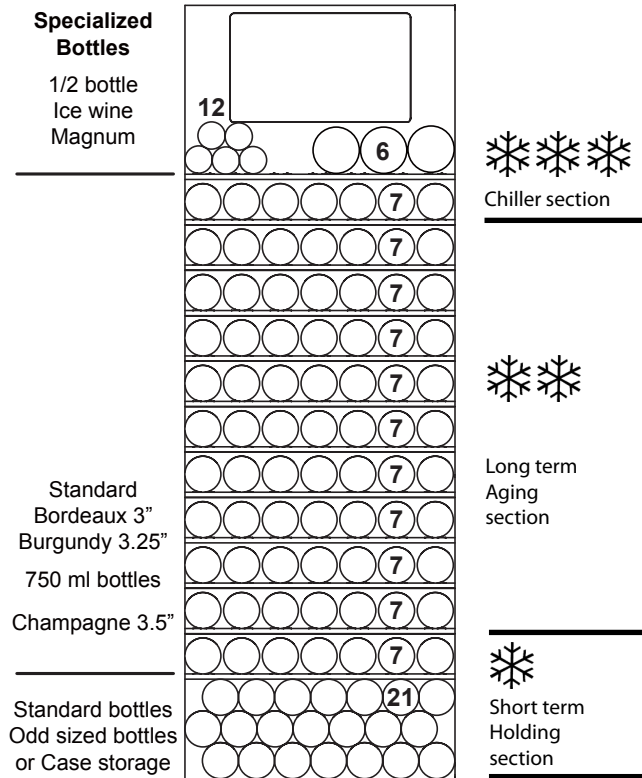

Maximum capacity 120 bottles
Based on 10% (12 x 1/2 bottles)

IMPORTANT NOTE

The top shelf of the cabinet should have the coldest temperature and may be used as your "chilling" section.

All Wine Cabinets have minor differences in temperature depending on where articles are stored. Top to Bottom differences will be present in any Cellar due to layering and pressure differences. The coldest temperatures will occur closest to the "Top" where the cold air originates.

The temperature readout represents samples of the air close to the position of the sensor. Other points in the cabinet will vary according to many factors, including the type of bottle loading, proximity to the door, corners, exposure to outside temperature, door usage etc. Just as in air conditioned rooms and refrigerators, not all locations measure the same temperature.

For example if you measure the air temperature exiting the coil, it will always be substantially colder than the set temperature. It is this basis that governs the ultimate temperature of any specific point in any cabinet.

Please make sure not to block the air flow under, and to the right side of the cooling unit. This would direct the cold air back into the cooling unit causing short cycles.

Remember, the important element for storing wine is constant temperature, not absolute temperature. We do guarantee that if your cellar is working normally the liquid temperature of your wine will not fluctuate even 1/4 of a degree C.

TROUBLESHOOTING GUIDE

Although each **WineKoolR™** cooling unit has been carefully tested at every stage of manufacture, occasional problems arise, the majority of which are due to rough or careless handling during shipping or installation. Other issues may occur due to improper cabinet assembly, power interruption or surge, low line voltage (less than your unit rating of 105V or 240V), or failure to clean the unit regularly (see illustration below). The following may help you determine what the problem may be; what steps you can take to correct it, and what further steps may be required. Additional Trouble-Shooting information and downloadable documents are available in the “Support” area of our website: www.koolr.com

CLEANING THE COIL:

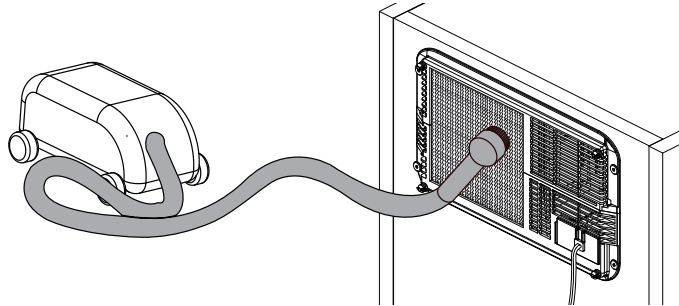

Coil is located at the top of back panel, vacuum it periodically.

IMPORTANT NOTE:

In order to provide maximum protection for your valuable wine collection, the following steps are highly advisable. First and foremost, have your wine collection adequately insured. Second, install a battery-powered heat-sensitive alarm daily basis. Fourth, install a high quality surge suppressor to protect against sudden power fluctuations. Fifth, clean the unit as directed, on a regular basis. Every 3 to 4 months vacuum the cooling unit coils (check our website for more info). Be advised, also, that **KoolR Products™** cannot in any event be liable or responsible for incidental or consequential damages.

IF:	CHECK:	THEN:
COOLING UNIT DOES NOT RUN AT ALL WHEN PLUGGED IN	<ul style="list-style-type: none"> • Is the unit plugged in? • Is the power supply operational? • Is the LED display functional? • Is there any evidence of shipping damage on the cooling unit or packaging materials? 	<ul style="list-style-type: none"> • Note that the unit has a 1-minute cautionary delay between plugging in and full start-up; this is a built-in safeguard to protect the compressor in the event of sudden power failure • Note that the power supply must be a dedicated, separately-fused and grounded 15 Amp, 120V line or 7.5 Amp, 240 V line rated for your unit. Must not use an extension cord. Do not share the outlet with other appliances • If the unit is receiving power yet fans or compressor fail to run, unplug for ten minutes, then try again. <p style="text-align: center;">for more help please go to : www.koolr.com/support.html (Troubleshooting)</p>
COOLING UNIT RUNS BUT DOES NOT COOL SUFFICIENTLY	<ul style="list-style-type: none"> • Is the storage temp properly set? • Is the cabinet properly assembled? • Is airflow to and from the cooling unit unobstructed? • Is the ambient air temperature within the specified range? • Are any exterior surfaces of the cabinet exposed to sunlight? 	<ul style="list-style-type: none"> • Note that the unit may take a few days to achieve the desired storage temperature, even in a properly located, airtight cabinet • Take steps to reduce ambient temperatures and compensate for additional heat gain if any cabinet walls receive direct sunlight • Take steps to improve circulation of air to and from the unit • Adjust the legs to level the door for proper magnetic gasket seal • Increase your SET TEMPERATURE • Clean the grill areas <p>If the problem persists, go to our website at www.koolr.com/support.html (Troubleshooting) and perform the “cooling unit diagnostic” in the support section.</p>

LIMITED WARRANTY AND PRODUCT SUPPORT

For detailed information consult the Warranty section of the "USE and CARE" guide!

ONE YEAR LIMITED WARRANTY

If your **WineKoolR™** cooling unit or cabinet fails to perform as designed within one year of the date of purchase, **KoolR Products™** warrants that, upon your request, it will be repaired or replaced, at our option, during the one year warranty period. This warranty applies only to the first end-user purchaser of a **WineKoolR™** cooling unit that is purchased and used in the continental United States or Canada (excludes Alaska and Hawaii). It is not valid for subsequent purchasers, nor for units in use outside North America. The warranty period for your cooling unit commences on the date you purchased it and expires one year thereafter.

PROOF OF PURCHASE

Within 10 days of purchase, complete and mail, fax or e-mail the registration sheet to **KoolR Products™**. Alternately, you may register your warranty on our Internet website, **www.koolr.com**. When you make a warranty claim, you must forward a copy of your original dated bill of sale to establish your date of purchase.

IF YOU HAVE A PROBLEM WITH YOUR UNIT

Customer service and warranty problems are handled online at **www.koolr.com**. You will find a comprehensive well documented and easy-to-use solution to almost any question or problem you may have. The inquiry forms are filled in on-line and connect you to our representatives who will process your requests for warranty service. This is the quickest way to solve your problems.

REPLACEMENT ?

At our option we may choose to offer you a replacement part or product rather than a repair. Upon your authorization to accept a replacement unit and with appropriate security (credit card authorization), we will promptly ship a replacement unit. The replacement may be a unit that has been reconditioned by **KoolR Products™**. The unit that needs service must be packed and returned to us, shipping prepaid. Upon its receipt, we will release your credit card security. Go online to the SUPPORT section on our website at **www.koolr.com** to request warranty service.

WHAT MUST YOU DO?

Your unit is designed to perform with a minimum amount of user maintenance when **installed and operated precisely as directed in the manual**. You are, however, responsible for the required user maintenance described in the manual, specifically, regular cleaning of the condenser coil. Also, you must take steps to protect the unit from sudden power surges. As with any sensitive electronic device, your **WineKoolR™** cooling unit may be damaged by power surges or spikes, including lightning strikes, acts of God, sudden interruptions or prolonged low-voltage conditions, which are not covered by this Warranty. You must monitor your unit's performance on a daily basis. If there is an apparent problem or "Alarm" condition, you must disconnect the power supply to avoid potential damage to your wine collection. It is your responsibility to insure your wine, and to take all reasonable and necessary precautions to safeguard its condition.

WHAT THE WARRANTY DOES NOT COVER

This warranty covers only defects in materials and workmanship provided by **KoolR Products™** and does not cover equipment damage or malfunction from misuse, abuse, accident, acts of God, or any unauthorized alteration or modification. The product must have been installed and operated precisely as directed in the manual which accompanies each product. Improper return shipping, inadequate packaging or shipping damage is not covered unless the unit is packaged and shipped in accordance with **KoolR Products™** replacement procedures. Third party servicing of this product during the warranty period will also void the warranty, as will any evidence of tampering or alteration to the serial number and or the original dated bill of sale.

REPLACEMENT AND REPAIR ARE YOUR ONLY REMEDIES

YOUR ONLY REMEDY UNDER THIS WARRANTY IS THE REPLACEMENT OR REPAIR OF YOUR ELIGIBLE PRODUCT AS DESCRIBED ABOVE. NEITHER THIS WARRANTY NOR ANY OTHER WARRANTY, EXPRESS OR IMPLIED, INCLUDING, BUT NOT LIMITED TO, THE IMPLIED WARRANTIES OF MERCHANTABILITY AND FITNESS FOR A PARTICULAR PURPOSE, SHALL EXTEND BEYOND THE ONE-YEAR WARRANTY PERIOD. UNDER NO CIRCUMSTANCES SHALL **KoolR Products™** BE LIABLE FOR ANY SPECIAL INCIDENTAL, INDIRECT OR PUNITIVE DAMAGES OR FOR ANY CONSEQUENTIAL DAMAGES, INCLUDING SPOILAGE OF WINE, EVEN IF **KoolR Products™** KNOWS OR IS INFORMED THAT SUCH DAMAGES ARE POSSIBLE. IT IS YOUR RESPONSIBILITY TO INSURE YOUR WINE, AND TAKE ALL REASONABLE, NECESSARY PRECAUTIONS TO SAFEGUARD ITS CONDITION. SOME STATES DO NOT ALLOW THE EXCLUSION OR LIMITATION OF INCIDENTAL OR CONSEQUENTIAL DAMAGES, SO THE ABOVE EXCLUSION OR LIMITATION MAY NOT APPLY TO YOU. NO RESELLER IS AUTHORIZED TO MODIFY THE TERMS OF THIS WARRANTY. ANY ADDITIONAL WARRANTY OFFERED BY A RESELLER IS THE SOLE RESPONSIBILITY OF THAT RESELLER.

SERVICE AFTER YOUR WARRANTY EXPIRES

If your unit requires service after the one-year warranty period expires, you may have it serviced locally by a qualified HVAC technician, or you may purchase a **new** unit at a **special discount** under our Extended Warranty Program. Please be ready to provide model, serial number, and your credit card. Let us assure you that local servicing will always be a **more** expensive and less satisfactory solution. More often than not repairs are not properly done and almost always take longer and cost more than purchasing a discounted **new** unit. Go online at **www.koolr.com** to request Replacement or see our Extended Warranty Program.



WineKoolR™

120

