

STRIVE SOCCER GOAL

# ASSEMBLY MANUAL

5 x 3 ft.  
1,5 x 1 m



# ASSEMBLY CHAPTERS

---

<b>Parts &amp; Tools</b>	Page	3
<b>1. Mount corners</b> (step 1-4)	Page	4
<b>2. Back stanchion</b> (step 5-9)	Page	6
<b>3. Connect crossbar &amp; backbar</b> (step 10-12)	Page	10
<b>4. Net</b> (step 13-14)	Page	11

## Get involved

Share your @muninsports videos and images



# PARTS & TOOLS



- 1) Ensure all the parts are included in the package before assembling Strive.
- 2) If any parts are missing or damaged, please contact us at [support@muninsports.com](mailto:support@muninsports.com). If any parts are damaged, please attach a photo to the e-mail.
- 3) Use the tools that are included. Please don't overtighten the nuts and bolts. You may need a rubber mallet (not included) for some steps. Please don't use a regular hammer.
- 4) Some assembly steps are best carried out by two people.

# 1. MOUNT CORNERS

1

F



L



2x



2

C

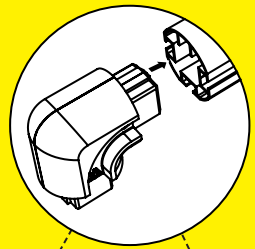
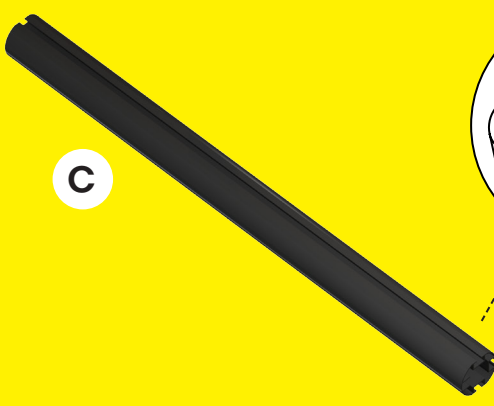

C

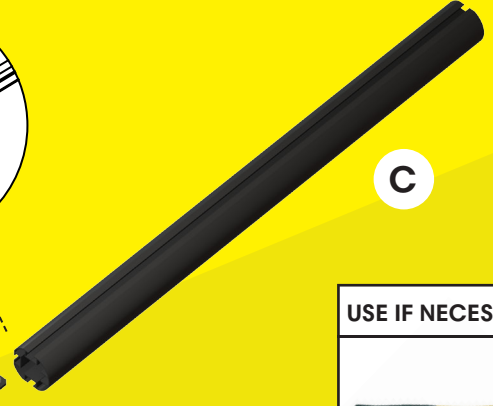

2x



**IMPORTANT**  
Do not tighten any of the screws at this step.

# 1. MOUNT CORNERS

3



4

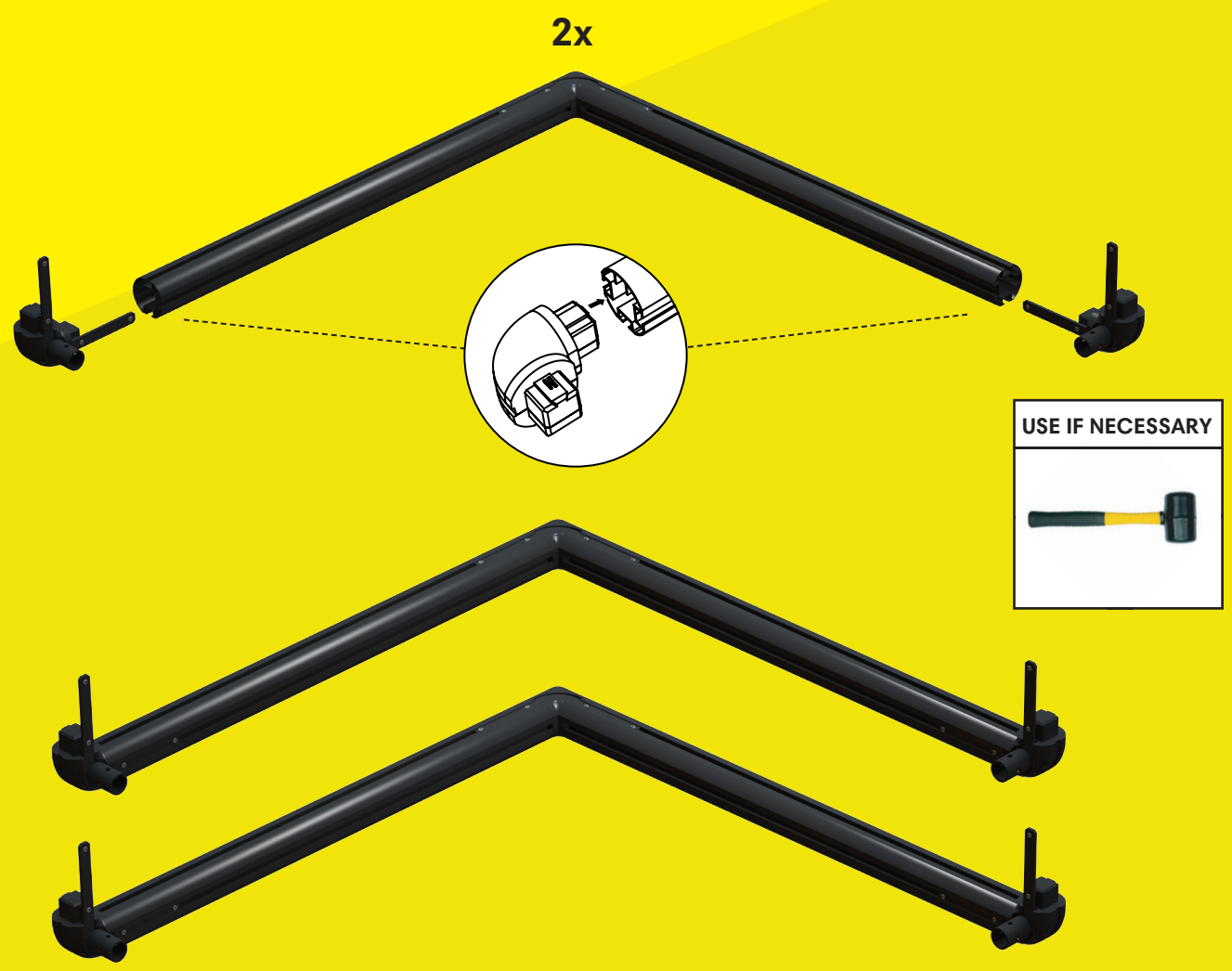

**IMPORTANT**  
Do not tighten any of the screws at this step.

## 2. BACK STANCHION

5

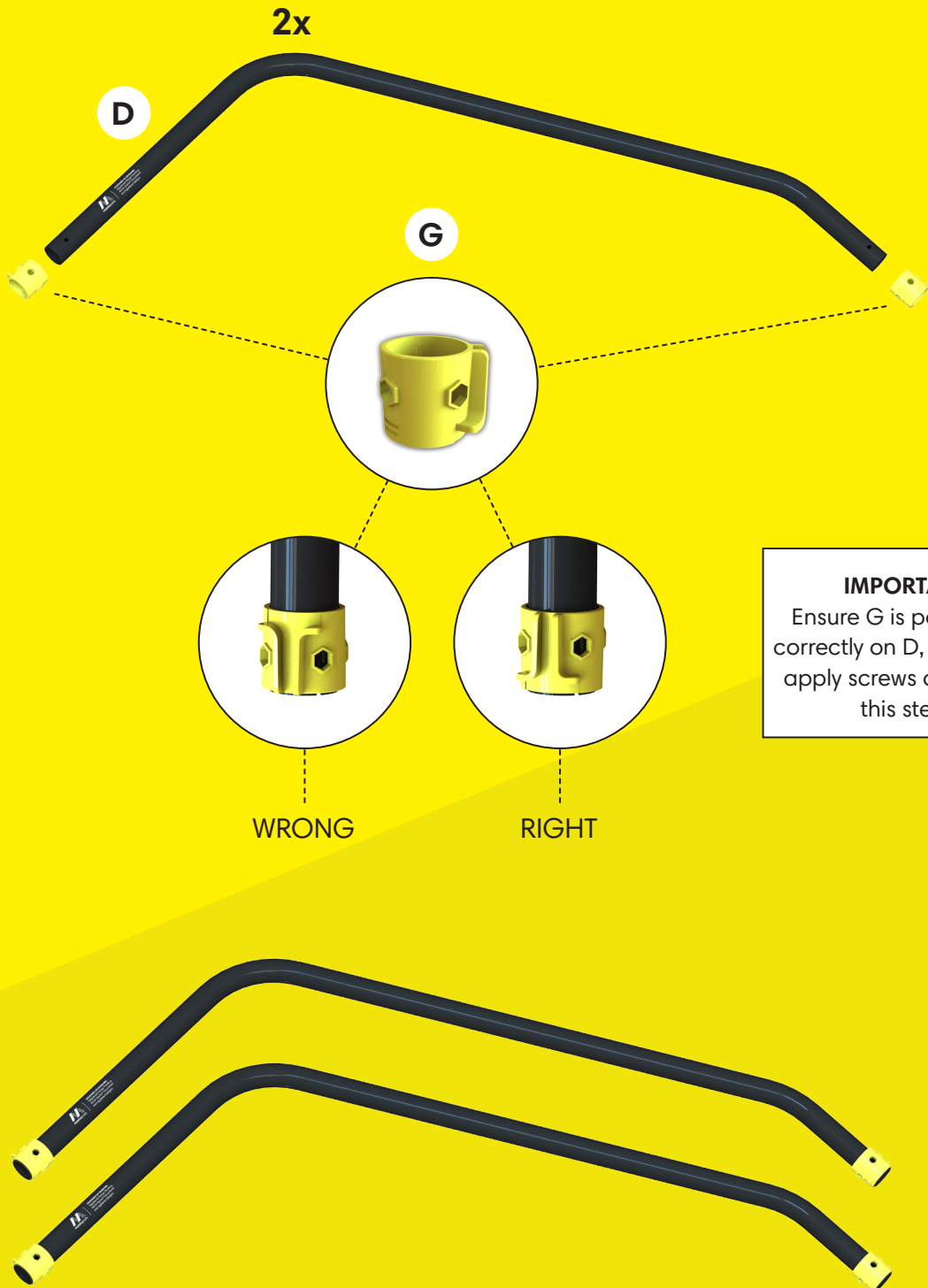

## 2. BACK STANCHION

6



7

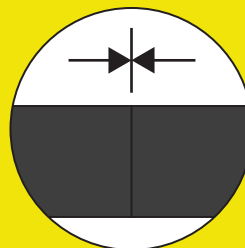
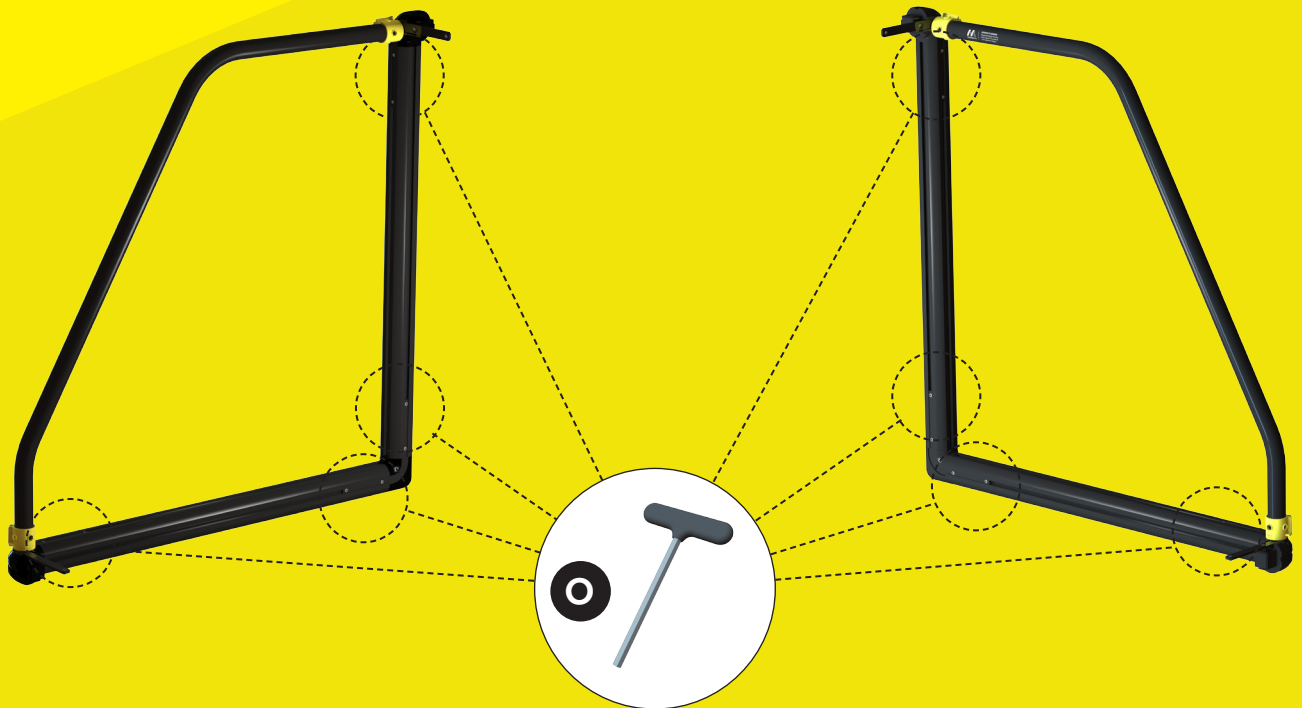

**IMPORTANT**  
Ensure no gaps exist between the corners and the posts before tightening the screws.

# 2. BACK STANCHION

8

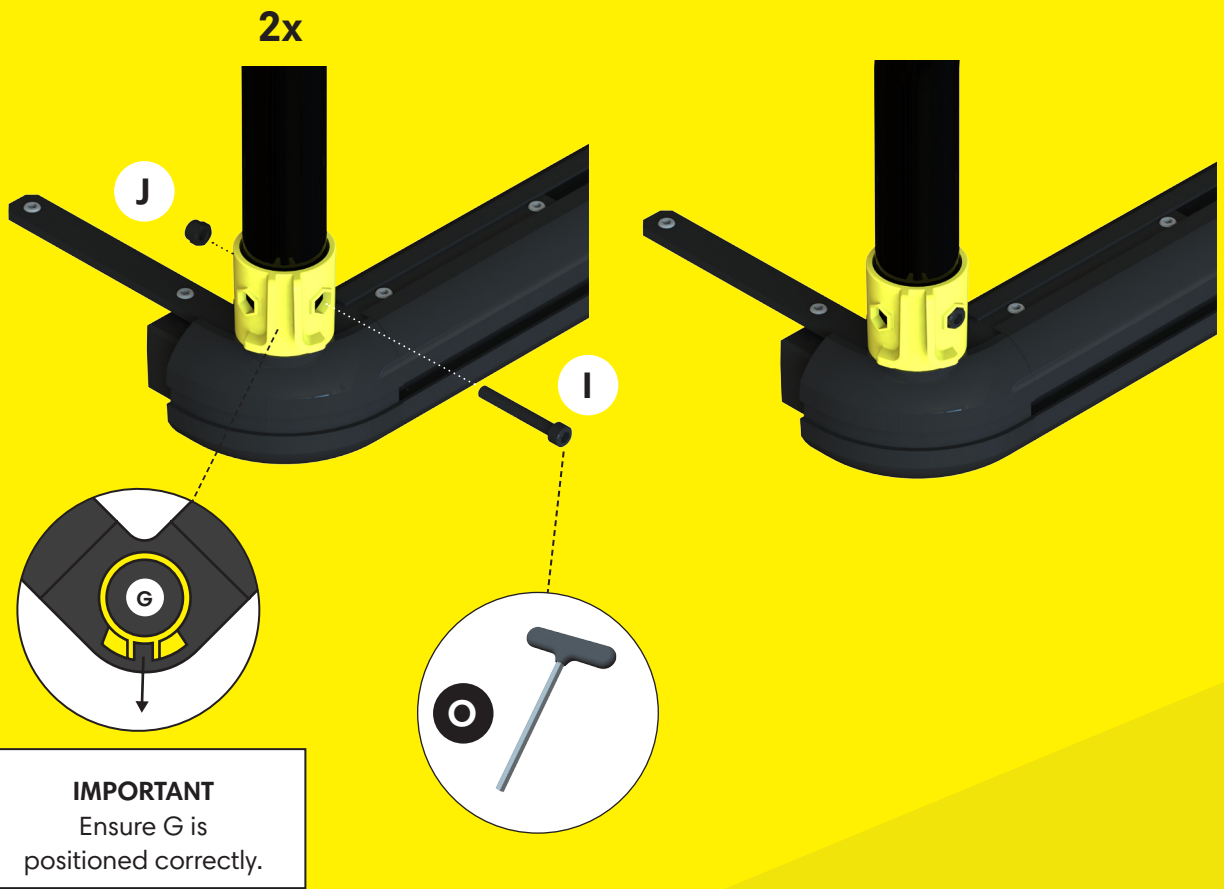

9

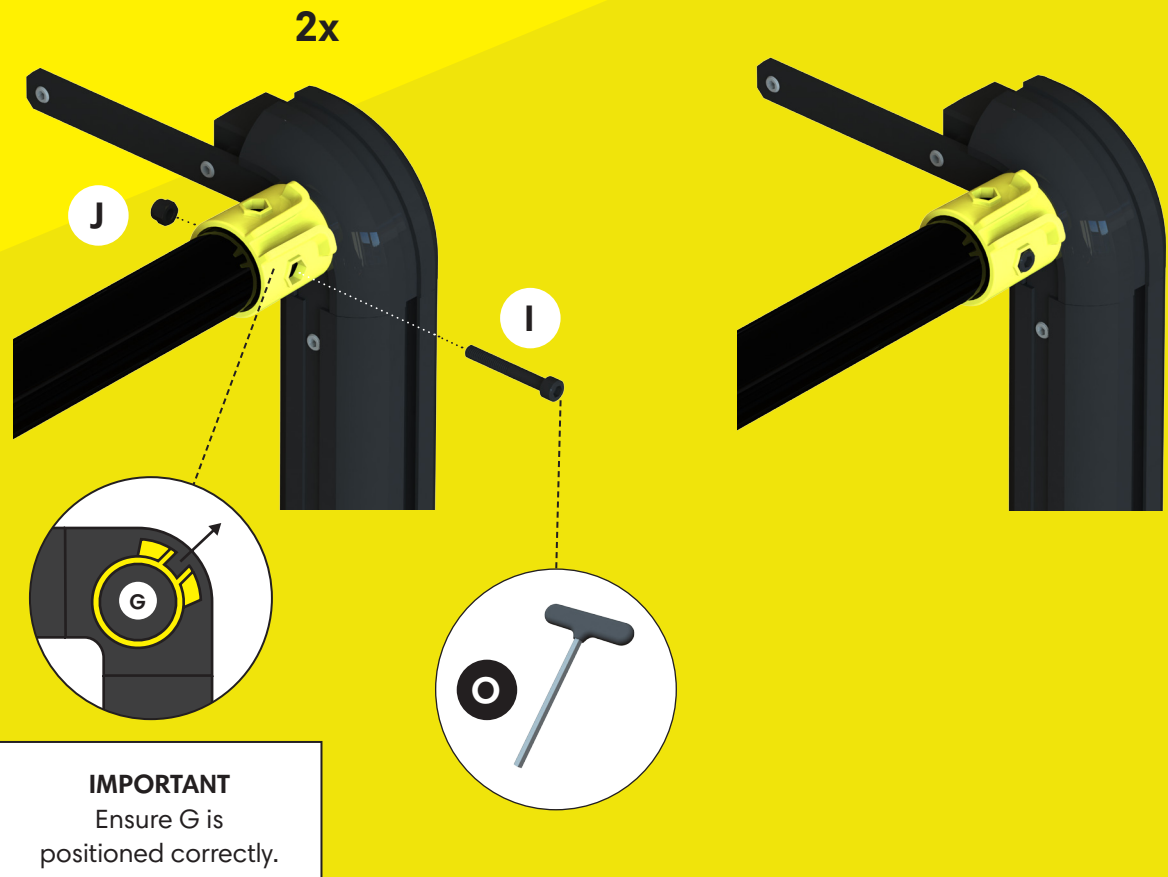



# 3. CONNECT CROSSBAR & BACKBAR

10

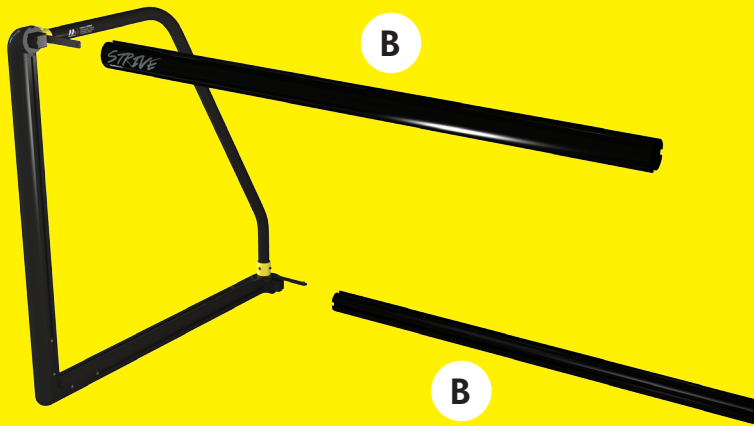

11

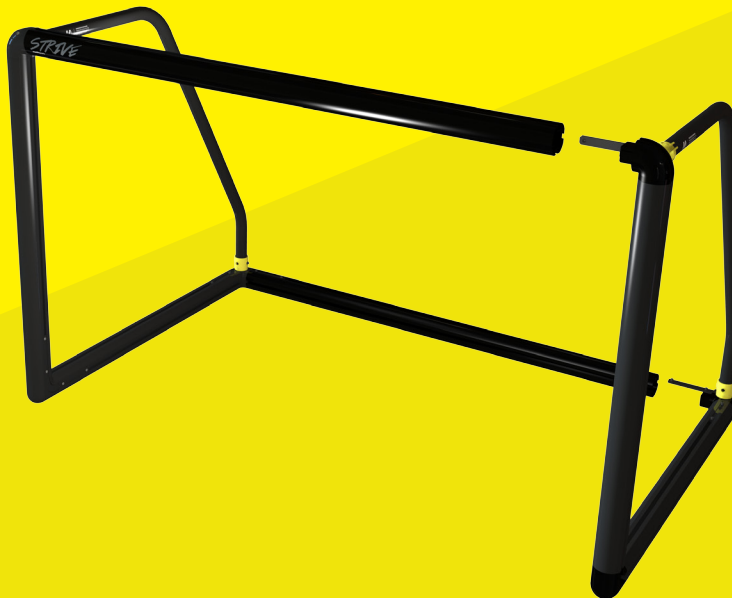

12

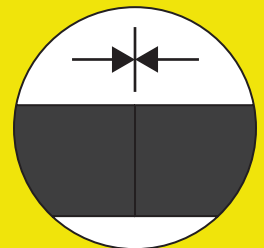
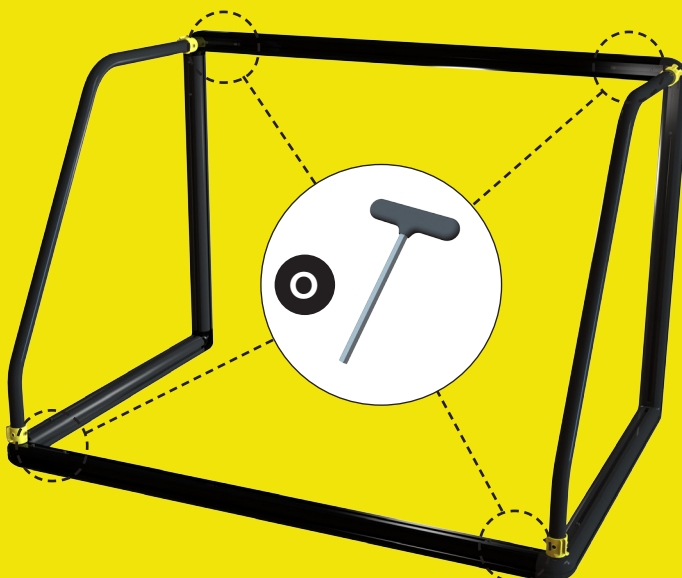

**IMPORTANT**  
Ensure no gaps exist between the corners and the posts before tightening the screws.

# 4. NET

13

K

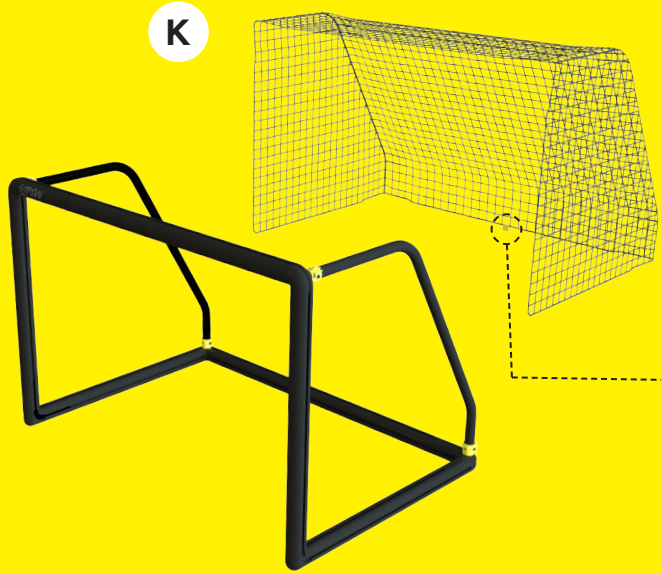

**IMPORTANT**  
Yellow mark must face down.

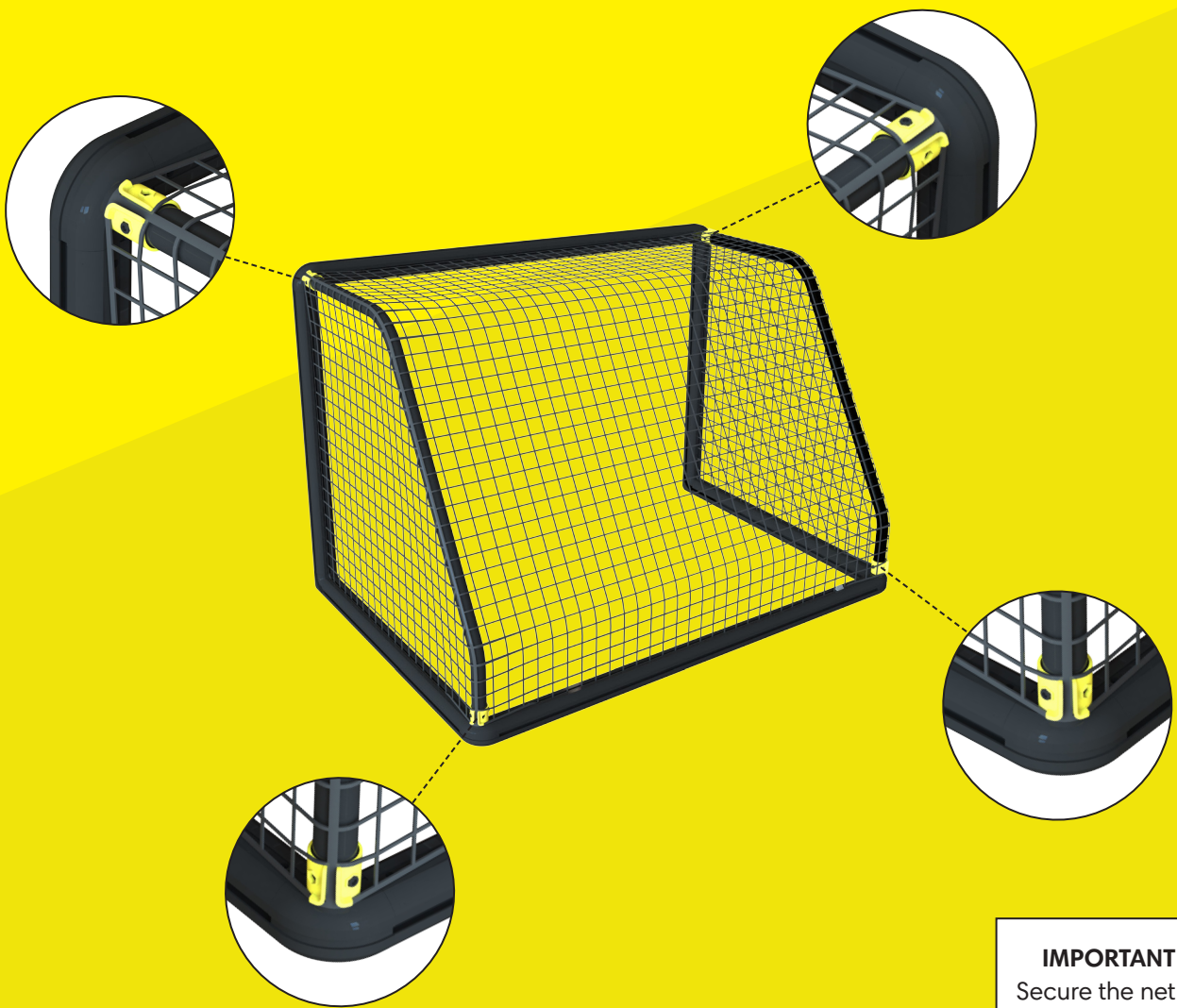

**IMPORTANT**  
Secure the net in the four G corners

# 4. NET

14

38x

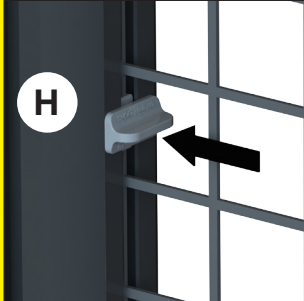

Insert holder into groove on top of net.



Turn holder 90 degrees



Holder in locked position.

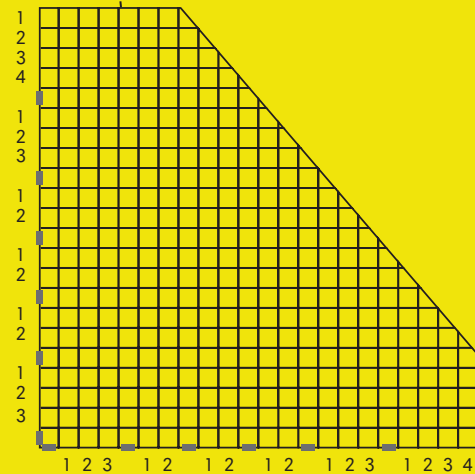
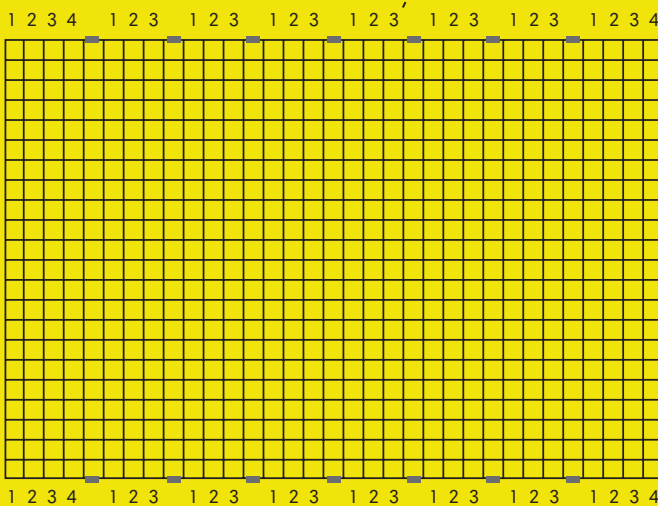
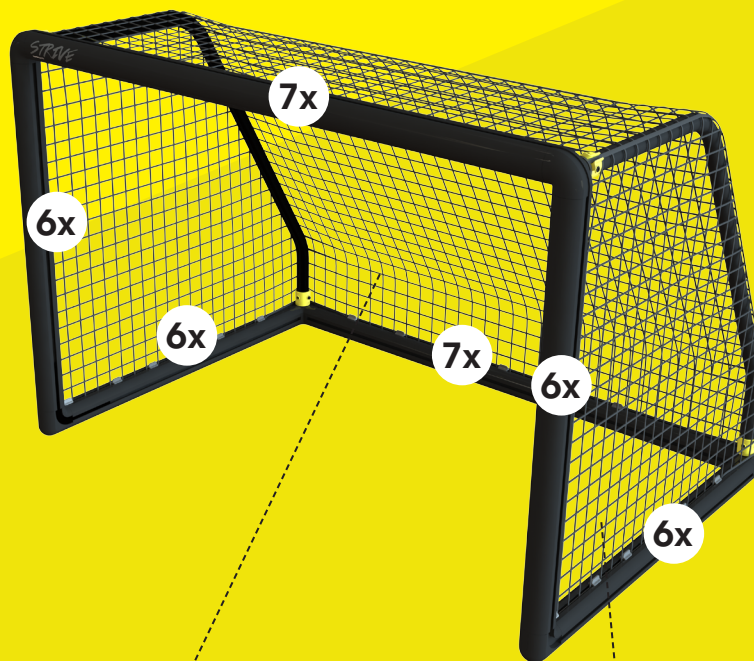

## Munin Sports

Havnegade 29  
1058 København  
Denmark

## Munin Sports USA

174 Ridge Road,  
Dayton, NJ 08810  
USA

+45 51250535  
info@muninsports.com  
www.muninsports.com

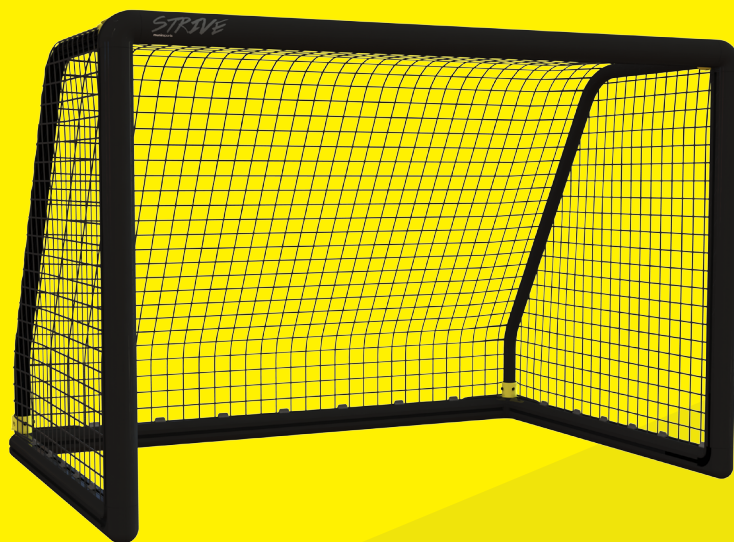

**WARNING:** Before starting to use Strive, the product should be assembled in accordance with the assembly manual. Munin Sports® is not responsible for injury or damage to persons or property resulting from the incorrect assembly of the product. Strive is a training apparatus developed for football/soccer training. Therefore, children should not use Strive without prior instructions from an adult skilled in training. We recommend that children under the age of 12 only use Strive if an adult is present. Particular attention is drawn to the fact that if Strive is not used according to instructions, small children risk becoming trapped in the assembled netting. Strive shouldn't be assembled, dismantled, moved, or handled without an adult. Munin Sports recommends that Strive is only used for the exercises explicitly presented on [www.muninsports.com](http://www.muninsports.com). Munin Sports disclaims all responsibility for injury and damage to persons or property caused during storage, exercises, or other use being undertaken to deviate from or in contradiction to the use presented on [www.muninsports.com](http://www.muninsports.com). Storage or use of Strive deviating from or in contradiction to the instructions takes place at the user's own risk. Do not climb or hang on the product. Do not grab the netting when you move the product. Strive is for backyard use.

