

Kombi

Ranger

User Manual



Fleet (Line Markers) Limited, Fleet House,
Spring Lane, Malvern, Worcestershire,
WR14 1AT



Tel: 01684 573535
sales@flmuk.com

www.fleetlinemarkers.co.uk

INTRODUCTION

Thank you for choosing the Kombi Ranger Line Marker from Fleet (Line Markers) Limited. Founded in the 1950's Fleet are regarded as the world's leading expert in the field of line marking.

Of course its not just the machines that Fleet are famous for, our range of line marking paints are used around the world, wherever the pitch, whatever the occasion.

Form more details on any of the products in Fleet's range please visit www.fleetlinemarkers.co.uk.

CONTENTS

-  Assembly
-  Operation
-  Maintenance
-  Storage
-  Troubleshooting
-  Parts List
-  Warranty

ASSEMBLING YOUR KOMBI RANGER MARKER

PREPARING FOR USE

1. Carefully remove the machine and accessories from packaging.
2. Insert handlebar section; adjust to suit user's height and tighten using thumb screws.
3. Bar ends can be adjusted to suit hand position using the supplied 5mm allen key.
4. Connect switch using the coiled power cable. (Fig 1)

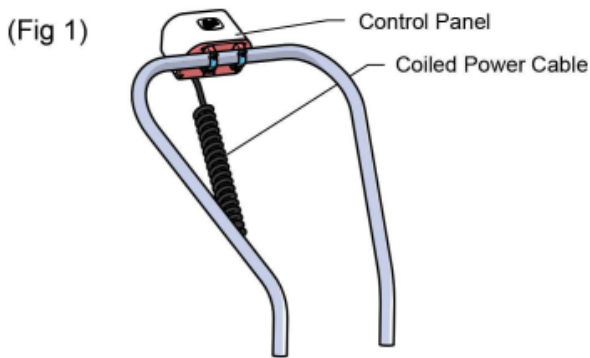

NOTE: failure to align keyways and forcing plug into socket **WILL** cause damage and **VOID WARRANTY**

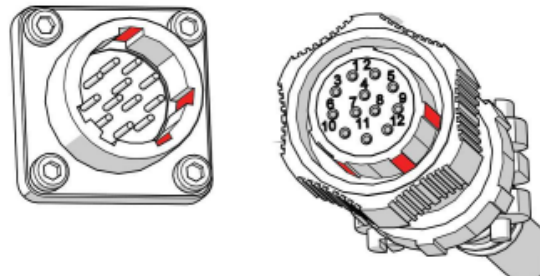

5. Lift bonnet, take out packing wedge and remove docking battery.
6. Position machine near a 230/240V AC power supply, dock the battery and switch on. (Fig 2)

CAUTION. Only use the supplied charger. Use of other equipment may cause fire or damage the battery. Maintain battery charge at all times, charge once a month if stored for long periods without use.

(Fig 2)

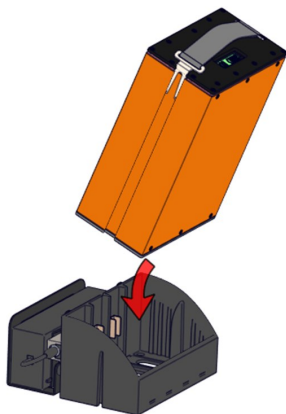

(Fig 3)

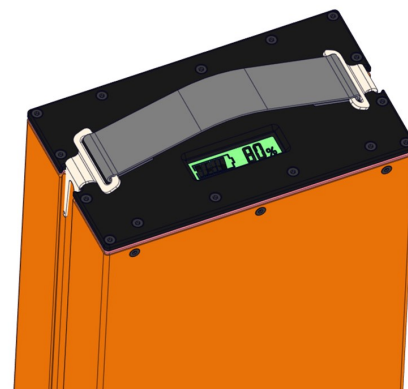

7. When charging the LED on the charger illuminates red. When the battery is fully charged, the LED illuminates green. Once green, remain charging for a further 60 minutes, a full charge can take 4-6 hours on average.
8. Once charged, dock battery within the machine. Battery status can be monitored by using the LED display on the battery.

9. You will need to connect the orange and blue pipes to the side of the machine, to do this the orange pipe connects to the fitting furthest forward on the machine. The blue pipe connects to the connection furthest back on the machine.

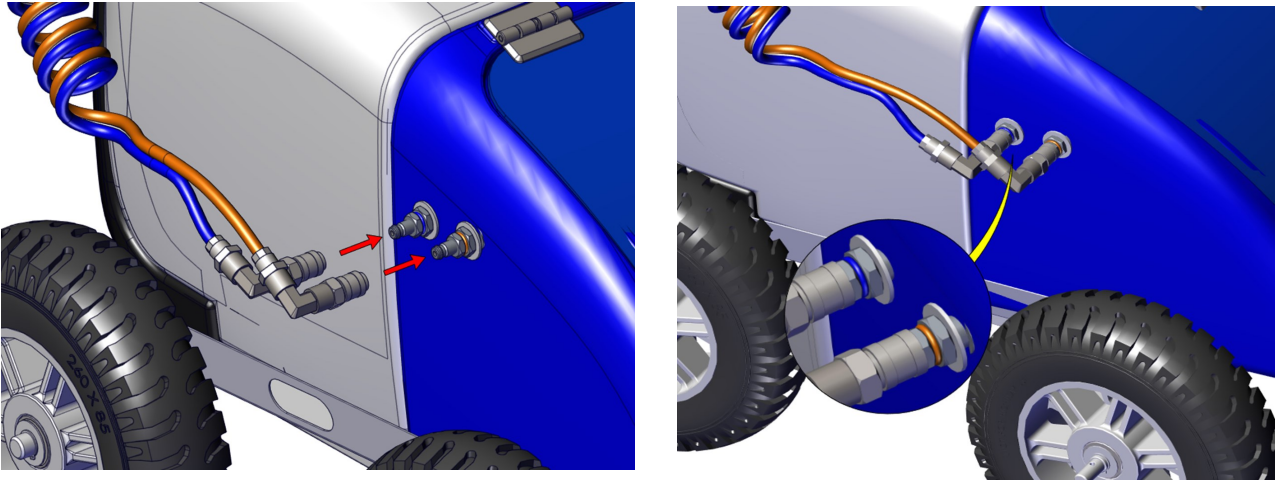

KNIB AND NOZZLE ASSEMBLY

The Knib and nozzle assembly is located inside the paint tank of the machine and requires some assembly before use.

Refer to the diagram below and follow these steps.

1. Remove packaging from tank.
2. Place arms (A) & (B) over the pivot bar (C)
3. Fit a washer (D) on each end of the pivot bar shaft, secure using R Clip (E)
4. Insert nozzle support arm (F) into the support pillar (G) and secure with thumb screw (H).

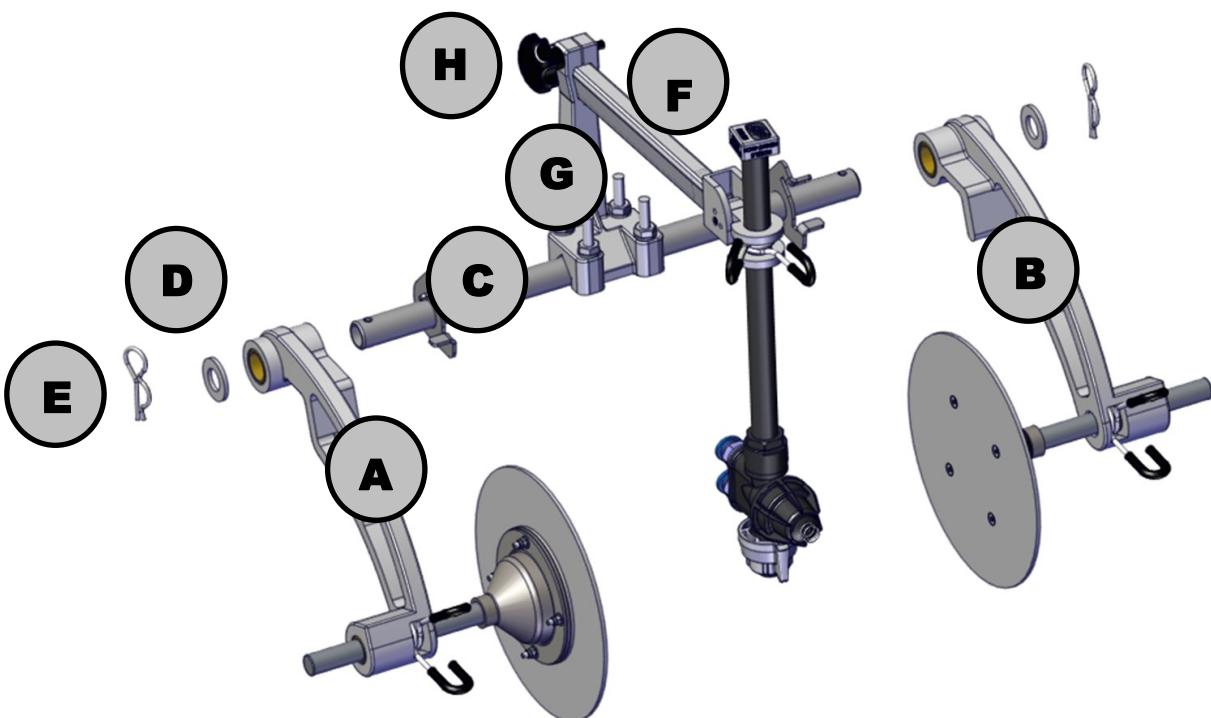

The knib and nozzle assembly can be fitted to the central post at the front of the machine or to either side of the front axle.

Front mounted knib and nozzle assembly

1. Fit the knib and nozzle assembly onto the tapered stem at the front of the machine.
2. Compress knib retainer clip and position the arm on the flat of the support pillar.
3. Hinge the nozzle assembly to the vertical position.
4. Ensure that the nozzle is centered between the line forming disks, adjust if necessary using the thumb screw.
5. Connect blue coiled hose to the front bulkhead connector.

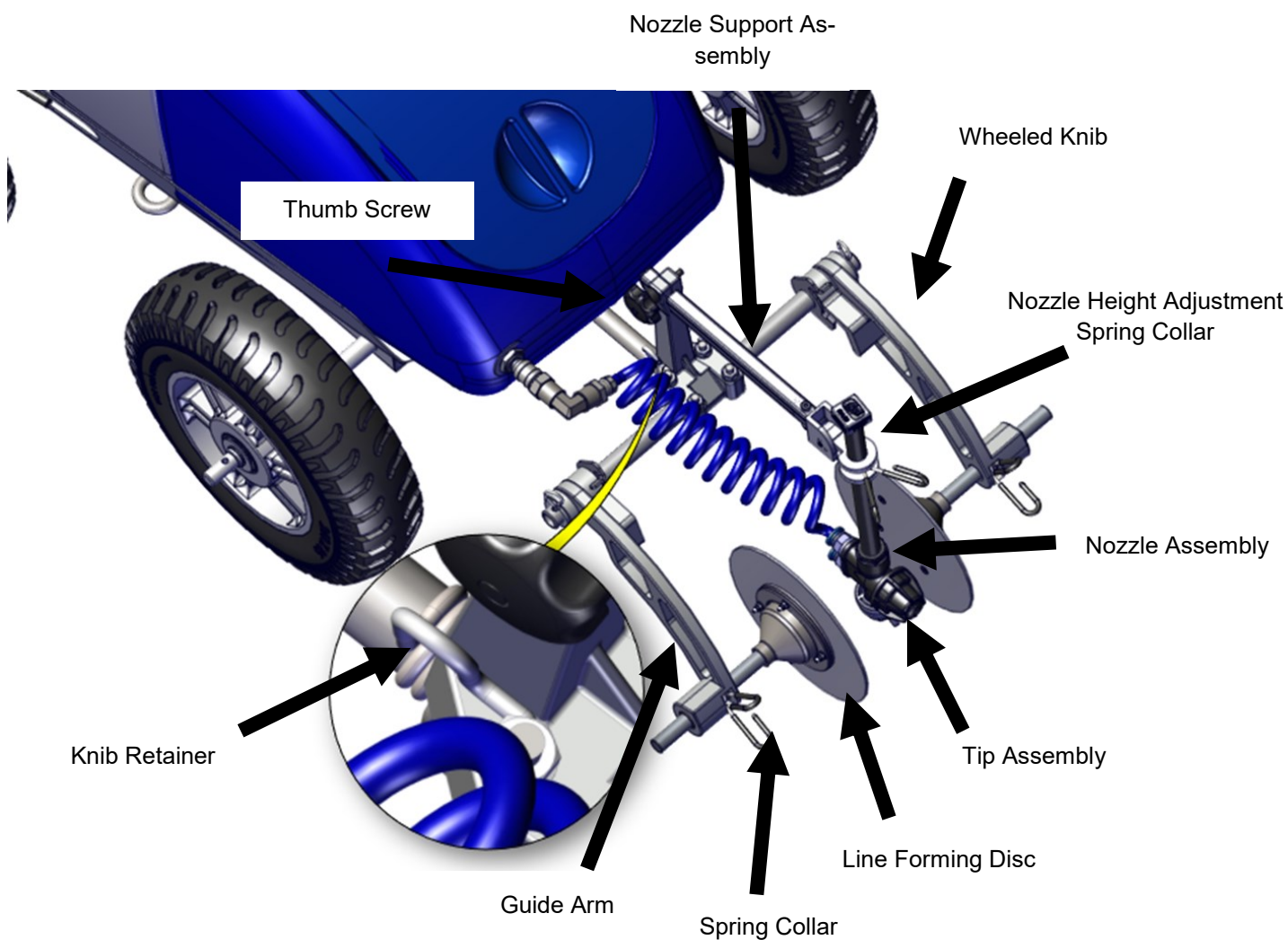

(Fig 4) Knib and nozzle assembly mounted on the front of the machine.

Side Mounting your Knib

1. Remove the R clip from the required side of the knib. (Fig 5)
2. Fit the pivot bar of the knib over the axle and align the holes. Refit the R clip to secure the knib to the axle.
3. Hinge the nozzle post to the vertical position and ensure that the nozzle is centered between the line forming discs . Adjust if necessary.

Note: Further adjustment of the nozzle position can be achieved by adjusting the U bolts.

4. Arrange the blue coiled hose away from the wheel and connect to the bulkhead fitting (Fig 6)

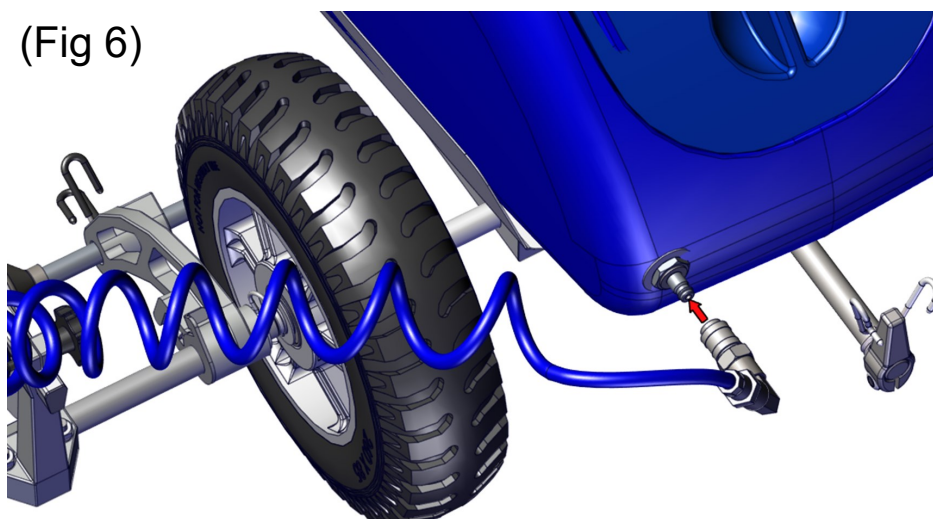
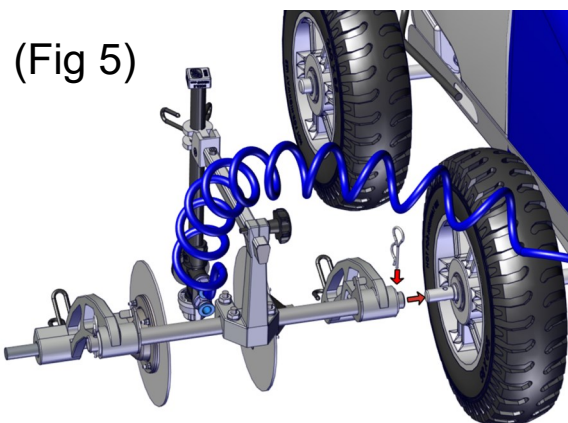

Note: Knib can be fitted in either trailing (Fig 7) or forward facing position. (Fig 8)

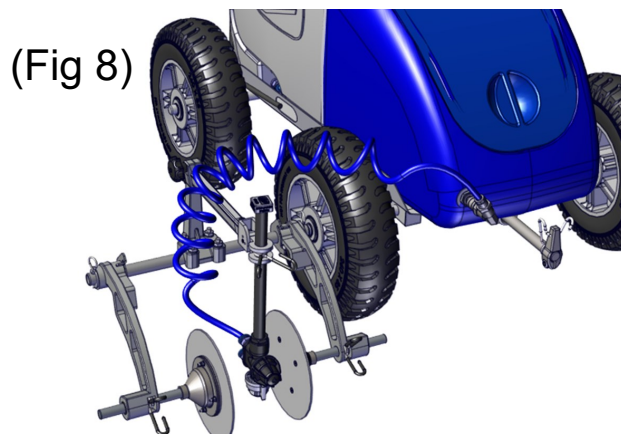
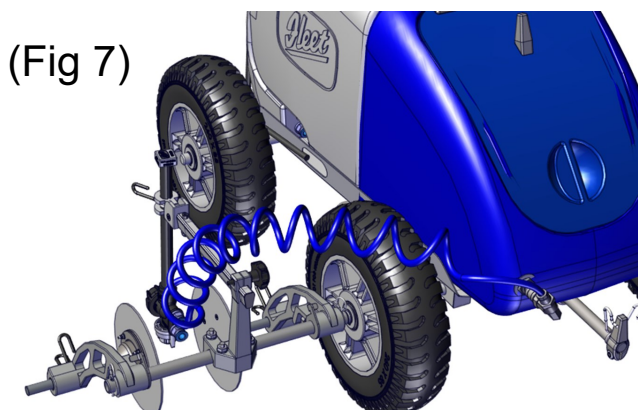

OPERATING YOUR KOMBI RANGER LINE MARKER

Filling the water tank

1. Remove the filler cap from the rear of the machine.
2. Fill the water tank with clean water, ensure no debris enters the tank and replace cap (Fig 10)

Fitting the paint drum

1. Shake the drum of paint thoroughly and place onto the machine so the lid of the drum is closest to the handlebars.
2. Unscrew the lid of the drum
3. Insert the Kombi Ranger draw hose into the drum and screw into the drum.

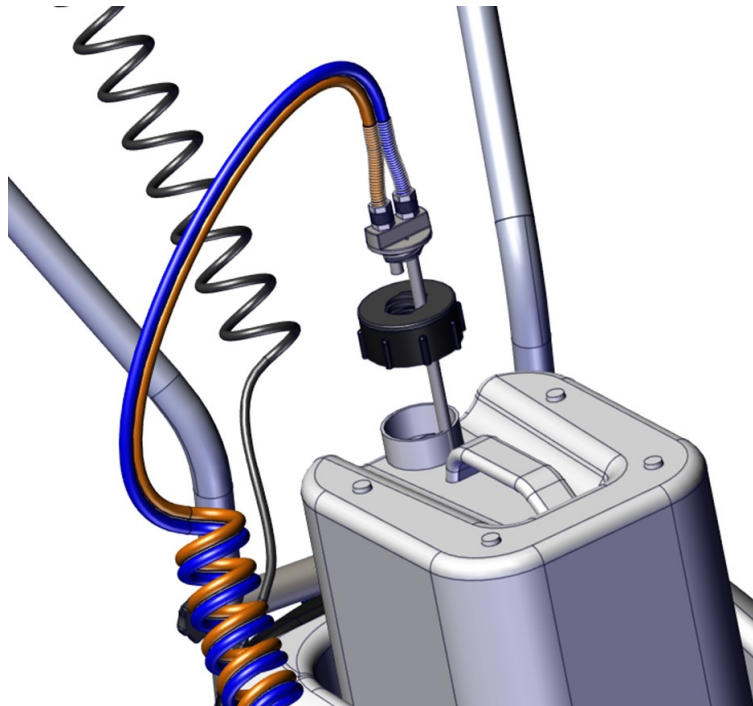

Flow return tap

The Kombi Ranger line marker is fitted with a flow return tap, this can be used for mixing concentrates and bleeding air from the system.

To operate the flow return system, proceed as follows:

1. Ensure the paint/water changeover valve is in the 'paint' position (lever pointing forward) (Fig 11)
2. Turn the flow return tap through 90 degrees (in line with hose. See Fig 12)
3. Switch the machine on by switching the ON/OFF switch, paint will now circulate around the system and back into the tank.

(Fig 11)

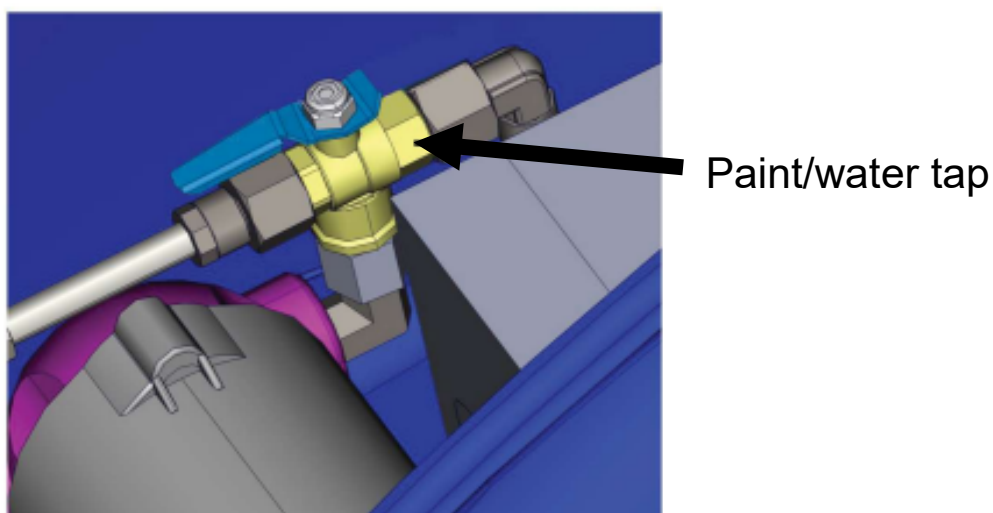

(Fig 12)

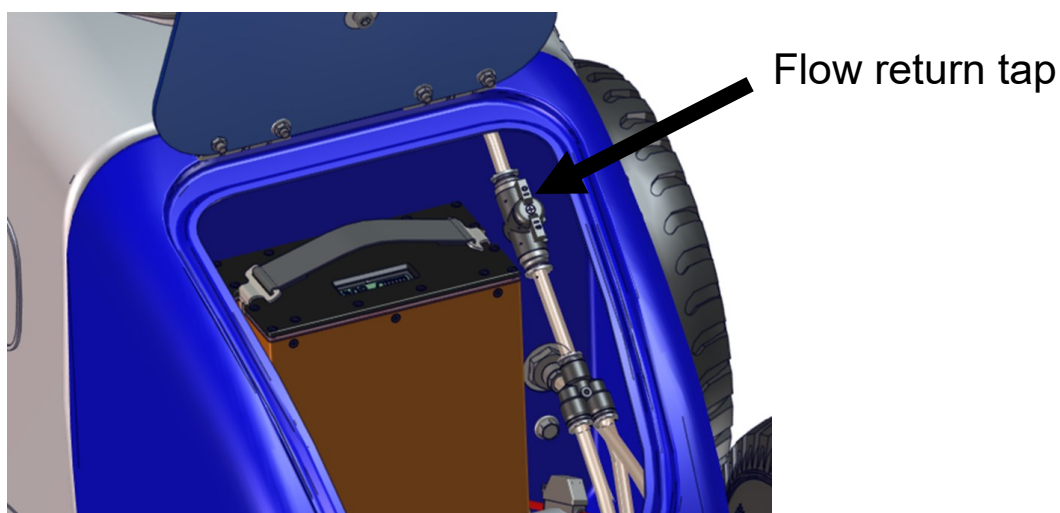

Setting the line width

The line width is determined by the width between the guide discs and the nozzle height. Both must be adjusted correctly to obtain a good line with the optimum paint usage. A ruler is located in the nozzle post for measuring the line width and the nozzle height.

1. With the line forming discs resting on the ground, compress the spring collars and slide the line forming discs in or out to achieve the desired line width.

IMPORTANT: Both the line forming discs must be adjusted so that the nozzle is central between them.

(Fig 13)

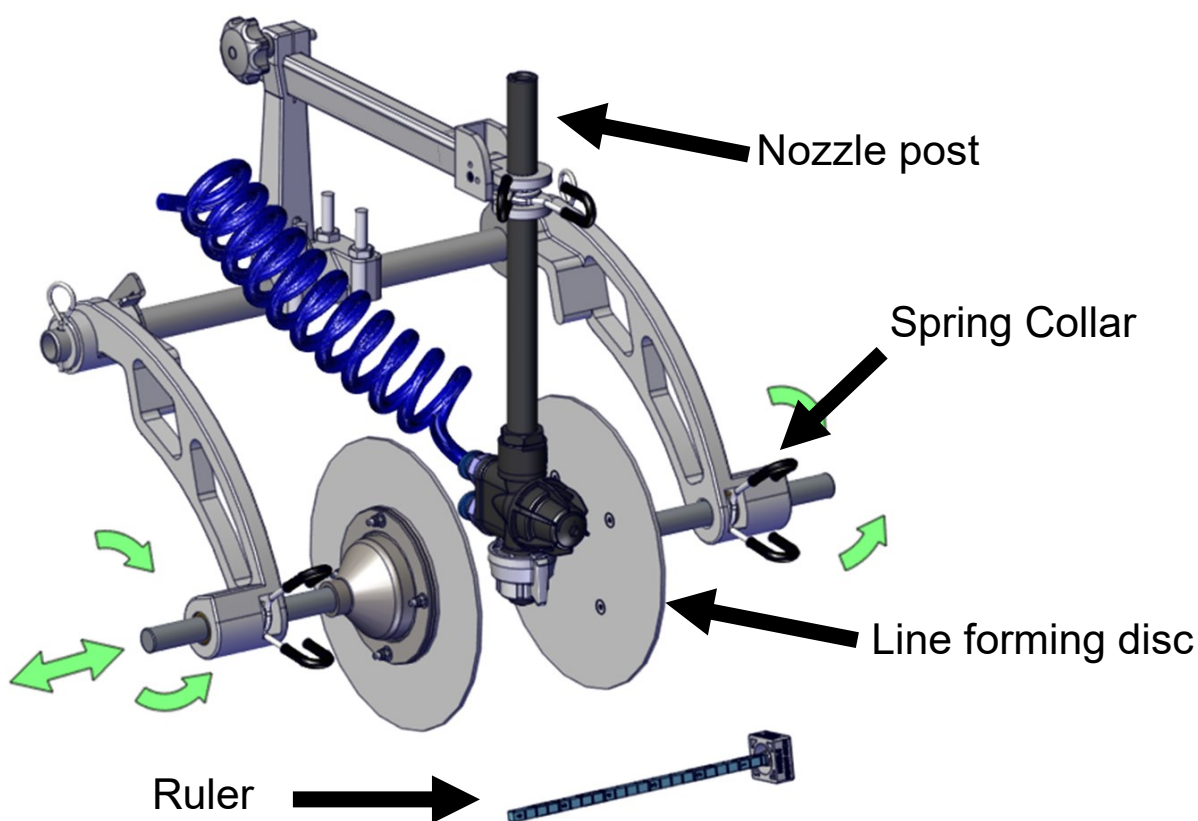

Setting the nozzle height

1. Hinge the nozzle post to the vertical position. Adjust the nozzle height by squeezing the spring collar and sliding the nozzle post up or down for the desired line width. A ruler is provided in the nozzle post.
2. A reference guide is located underneath the bonnet and give approximate nozzle height for a range of line widths. NOTE: this is only intended as a guide. The operator must observe the spray pattern and adjust the nozzle height to form a good line for the local conditions

3. On an area of the ground away from the pitch, briefly switch on the pump. Observe the spray pattern, check that the spray fan just reaches the line forming discs at the top of the grass height. For hard surfaces the spray fan should just reach the line forming disc at the ground surface. If necessary adjust the nozzle height. Turn off the pump

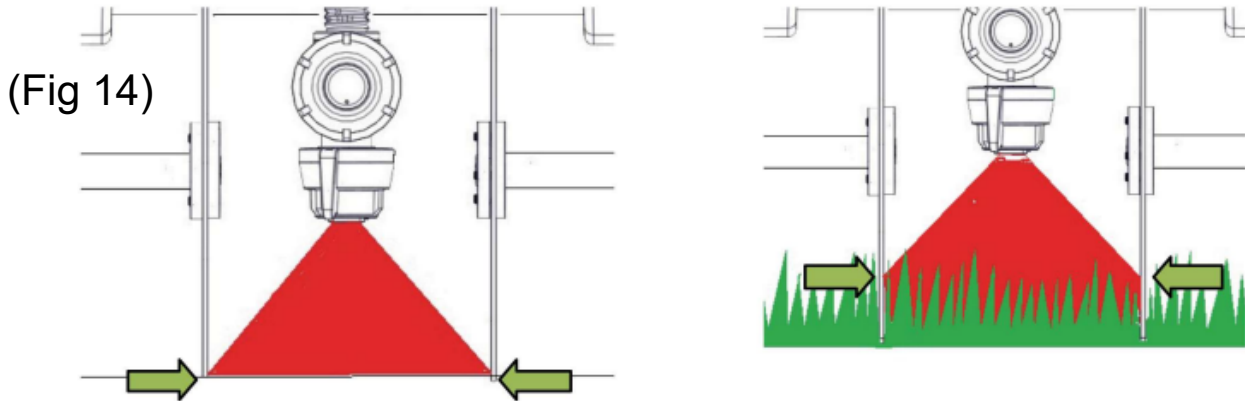

4. Close the bonnet. Ensure the blue coiled hose is arranged with no kinks and is not fouling on the guide discs. The Kombi Ranger line marker is now ready for line marking.

LINE MARKING WITH YOUR KOMBI RANGER LINE MARKER

WARNING HIGH PRESSURE - THE KOMBI RANGER LINE MARKER HAS A WORKING PRESSURE OF UP TO 80psi. DO NOT OPEN ANY PIPE JOINTS WHILST THE PUMP IS OPERATING.

Setting the pressure

The pressure of the spray can be adjusted for different applications by turning the pressure adjustment knob clockwise/anticlockwise on the control panel. The digital display will indicate machine pressure.

NOTE: The lower the pressure, the greater the paint economy. Pressure below 18psi will not overcome the DCV (Drip control valve) and therefore will not spray.



Marking a line

1. Ensure there is correctly mixed product in the paint tank.
2. Ensure the battery is fully charged
3. Paint/water valve is in the 'paint' position (lever pointing forward)
4. Ensure the flow return tap is in the OFF position (tap lever at 90 degrees to the hose)
5. Switch the pump ON and immediately start walking at a steady speed along the guide line. The guide line could be a previously marked line, string or chalk line.
6. At the end of the line switch the pump OFF and stop walking.
7. Lift the line forming discs from the surface and position the machine at the start of the next line.
8. If there is to be a break in marking always flush the nozzle with water using the Paint/water change over tap. Briefly flush the nozzle into a container or on waste ground away from the pitch area. Refer to page 12.

Marking Circles

An eyelet is located on the chassis (left hand side) to aid marking circles. This can be used with a string or chain line located off a central point allowing the machine to maneuver in a uniform circle (Fig 16).

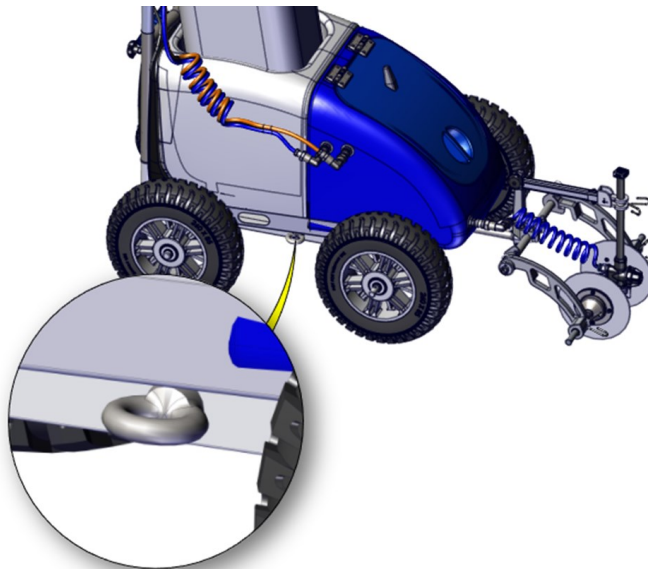

FLUSHING AND CLEANING

IMPORTANT: When cleaning./flushing the Kombi Orange line marker, ensure that water courses are not contaminated with paint. If in doubt, check with the local authority.

Quick flush (daily)

This can be used before breaks in operation or at the end of a line marking day.

1. Ensure that the water tank has sufficient water for the cleaning operation.
2. Position the machine where the contents of the pipework can be flushed and cleaned.
3. With the paint/water tap in the 'water' position (Fig 17), turn on the pump. Allow the water to spray through the nozzle, when clear water is observed turn off the pump.

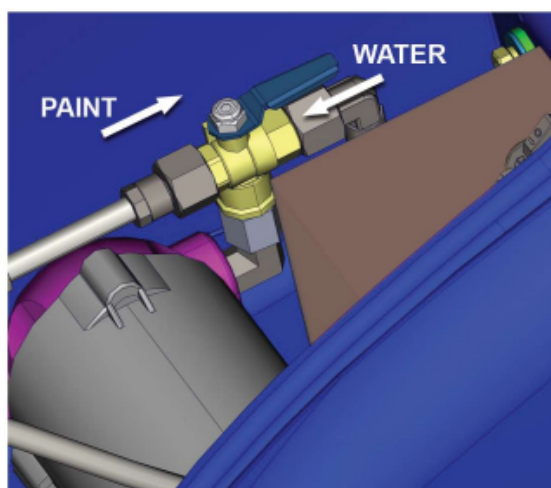

(Fig 17)

Full System flush (weekly)

It is not recommended to store paint in the machine for longer than 24hrs

1. Ensure that the water tank has sufficient water for the cleaning operation.
2. Position the machine where it can be flushed and cleaned.
3. With the supplied clean drum, fill with clean water and add Kombi Klean.
4. Position the nozzle assembly over a drain or suitable container.
5. Place probe from paint drum into clean water drum and flush
6. With the paint/water change over tap in the 'paint' position (Fig 17), turn on the pump. Allow the water to spray through the nozzle until the drum is empty.
7. Remove the bayonet cap complete with the nozzle tip and filter. If necessary, rinse to clean.
8. Refit the bayonet cap complete with the nozzle tip and filter
9. Using a damp cloth lean any paint overspray from the following:
 - A. Line forming discs and guide shafts. Build up of paint on the guide shafts will make line width adjustment more difficult
 - B. Generally clean and remove paint overspray or spills from the machine

MAINTENANCE ACCESSORIES

These accessories are available from the Fleet Line Markers online store. Visit www.fleetlinemarkers.co.uk for more details.

Fleet Ultrasonic Cleaner

Manufactured to use with all Fleet nozzle tip line marking machines, the ultrasonic Nozzle Tip Cleaner works through the cavitation effect caused by high frequency ultrasonic wave vibrations in the fluid, providing an effective solution for the removal of paint, dirt and grime which would normally require tedious manual cleaning by hand.

The cleaner can be used with a wide variety of Fleet machine parts including nozzles, filters, pipework and couplings, returning them to an almost new condition without any damage.



Fleet Kombi Klean

Manufactured to use with all Fleet machines. The Kombi Klean helps to flush through the pump and pipework the clean then of paint after us of the machine. Suitable for use on the machine inside and out.



STOWING THE KOMBI RANGER LINE MARKER

When the machine has been flushed and cleaned, prepare the Kombi Orange line marker for transport or storage as follows:

1. Squeeze nozzle height adjustment spring collar and slide the nozzle post down to the minimum height.
2. Using the spring collars, slide the line guide discs in, so that they support the nozzle assembly centrally.
3. Loosen knib retainer clip and lift the knib from the tapered post.
4. Park the knib onto the bonnet horn.
5. The Kombi Ranger line marker is now ready for transportation and/or storage.



TROUBLESHOOTING

If the Kombi Ranger line marker is not producing the perfect line, the table below is to help diagnose and remedy simple issues. The main cause for failure is inadequate cleaning/flushing. It is imperative to keep the paint system free from dried paint particles.

Note: These procedures presume that there is sufficient Fleet paint in the paint tank.

No	Issue	Cause	Remedy
1	Intermittent line/ pressure Gauge flickering	Airlock in paint system	A. Fill water drum with clean water B. Insert draw hose and purge water through the pipework. C. Once airlock is clear remove water drum and replace with the paint drum.
2	Line striping	1.Nozzle tip contaminated 2. Insufficient pressure	A. Remove the nozzle and clean in Fleets Nozzle Tip cleaner sonic bath. B. Replace with new nozzle. Increase pressure using the pressure adjustment knob on the control panel
3	Low pump pressure	Low Battery Charge	Use battery monitor to check battery status. Recharge battery
4	No machine power	1.Low battery charge 2. Fuse blown	Use battery monitor to check battery status. Recharge battery. Check blade fuse and replace if necessary
5	Pressure increasing	Blockage	A. Check nozzle and top hat filter for residue, clean and replace. B. Replace with new nozzle and filter.

Quick Connectors

Removal

1. To release a pipe from a quick connector, push on both sides of the blue collar.
2. With the collar pushed in, pull the pipe from the connector.

Replacement

1. To replace a pipe into a quick connector, simply push in the pipe. The pipe should be inserted 15mm to ensure a good connection.

Compression fittings

Removal

1. To release a pipe from a compression fitting use an 12mm,13mm or 14mm spanner (dependent on fitting) to loosen the end cap.
2. Pipe can be pulled out.
3. The use of two spanners maybe required if the compression fitting is to be replaced.

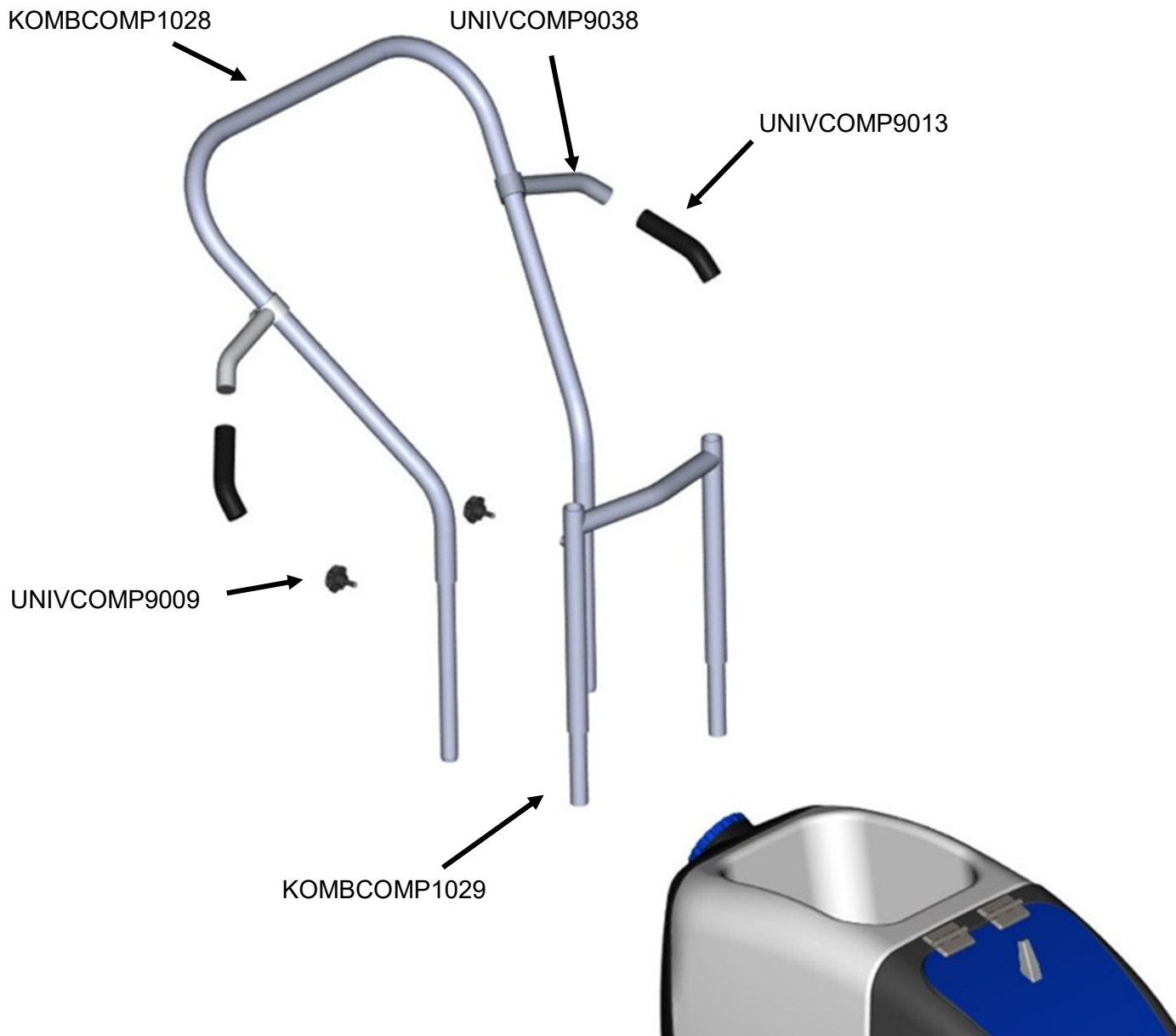

Diagrams

PART NO	PART NAME
KOMBCOMP1028	Handle Bar Top Section
KOMBCOMP1029	Handle Bar Bottom Section
KOMBCONS1003	M6 x 25 Socket Cap Head Screw
UNIVCOMP9009	M6 Thumb Screw (Not shown)
UNIVCOMP9013	Rubber Handle Grips
UNIVCOMP9038	Bar Ends (Pair)
UNIVCONS9058	M6 x 20 Flat Repair Washer (Not Shown)

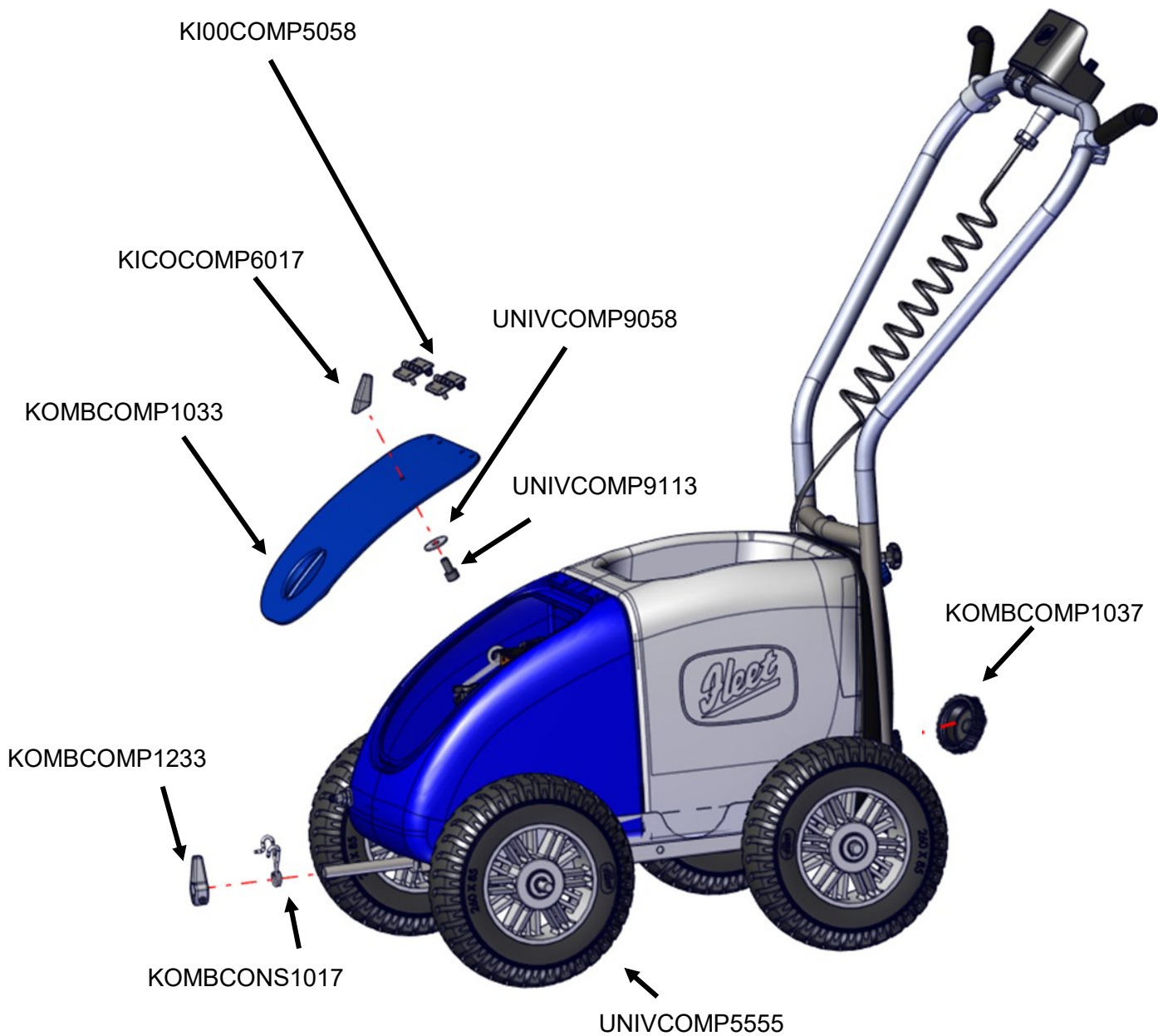

PART NO	PART NAME
UNIVCOMP5555	Wheel & Solid foam tyre
KI00COMP5058	Bonnet Hinge (Sprung)
KICOCOMP6017	Bonnet Horn
KOMBCOMP1233	Tapered Stem
KOMCOMP1033	Bonnet
KOMBCOMP1037	2 Inch vented water cap
KOMBCONS1017	15mm Retaining Clip for Knib
UNIVCONS9058	M6 x 20 Flat Repair Washer
UNIVCONS9113	M6 x 12 Socket Cap Head Screw

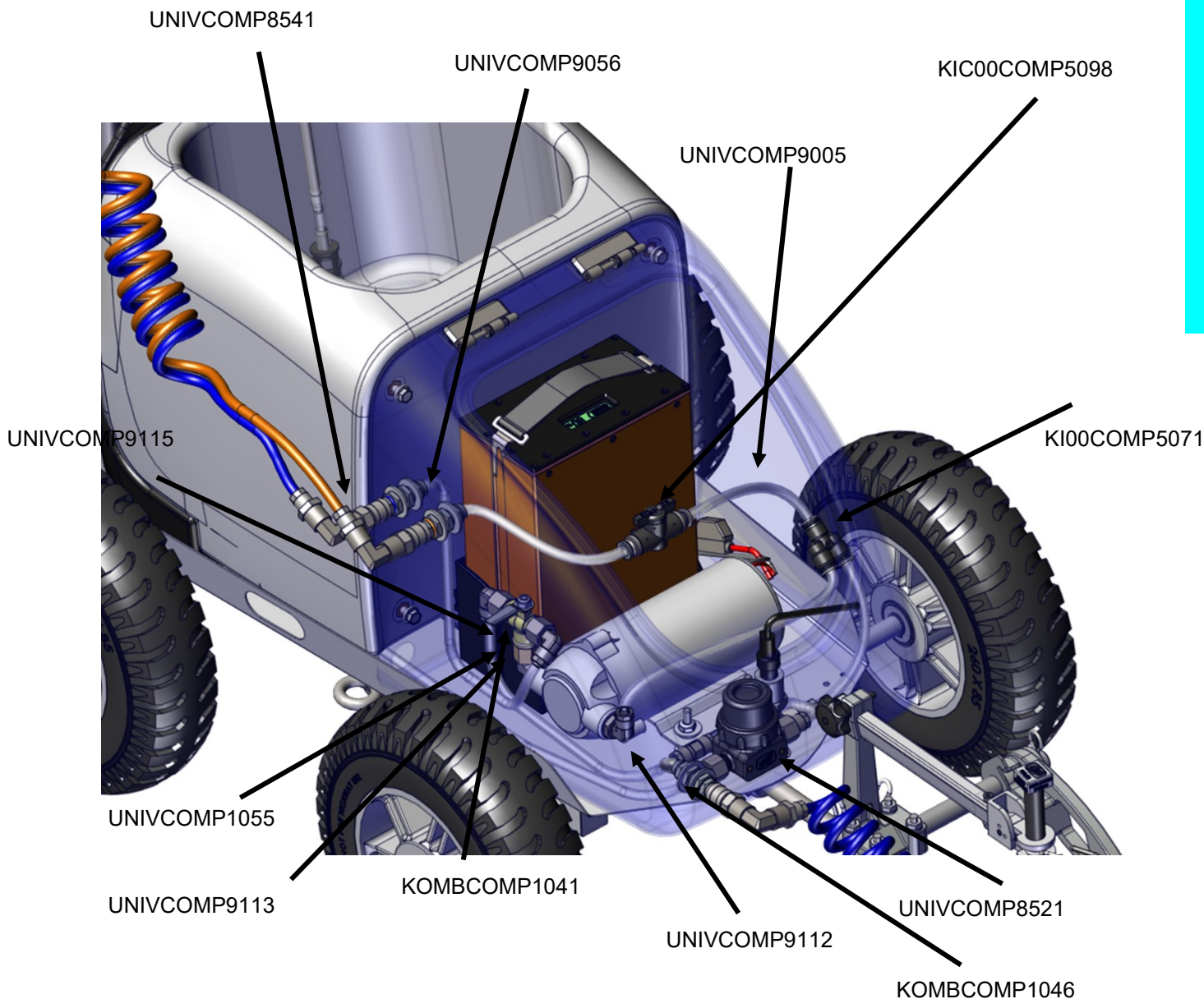

PART NO

PART NAME

KI00COMP5071	Y Shaped Connector 8mm
UNIVCOMP8521	Bowl Filter Complete
KI00COMP5098	Push Fit Hand Valve
KOMBCOMP1046	1/4 BSP Male Thread Female Coupler
KOMBCOMP1041	Paint Water Tap 3 Way
UNIVCOMP1055	1/4 BSPT M—1/4 BSP F Brass
UNIVCOMP9005	Clear PVC Hose
UNIVCOMP9056	Quick Release Compression fit Bulkhead
UNIVCOMP9112	3/8 Elbow Connector
UNIVCOMP9113	1/4 Male/ Male Elbow
UNIVCOMP9115	Female Pipe Elbow
UNIVCONS9086	6mm Male Bullet Red Terminal Connector (Not illustrated)
UNIVCONS9087	6mm Female Red Receptacle Terminal Connector (Not illustrated)
UNIVCOMP8541	Quick Release Elbow Coupling

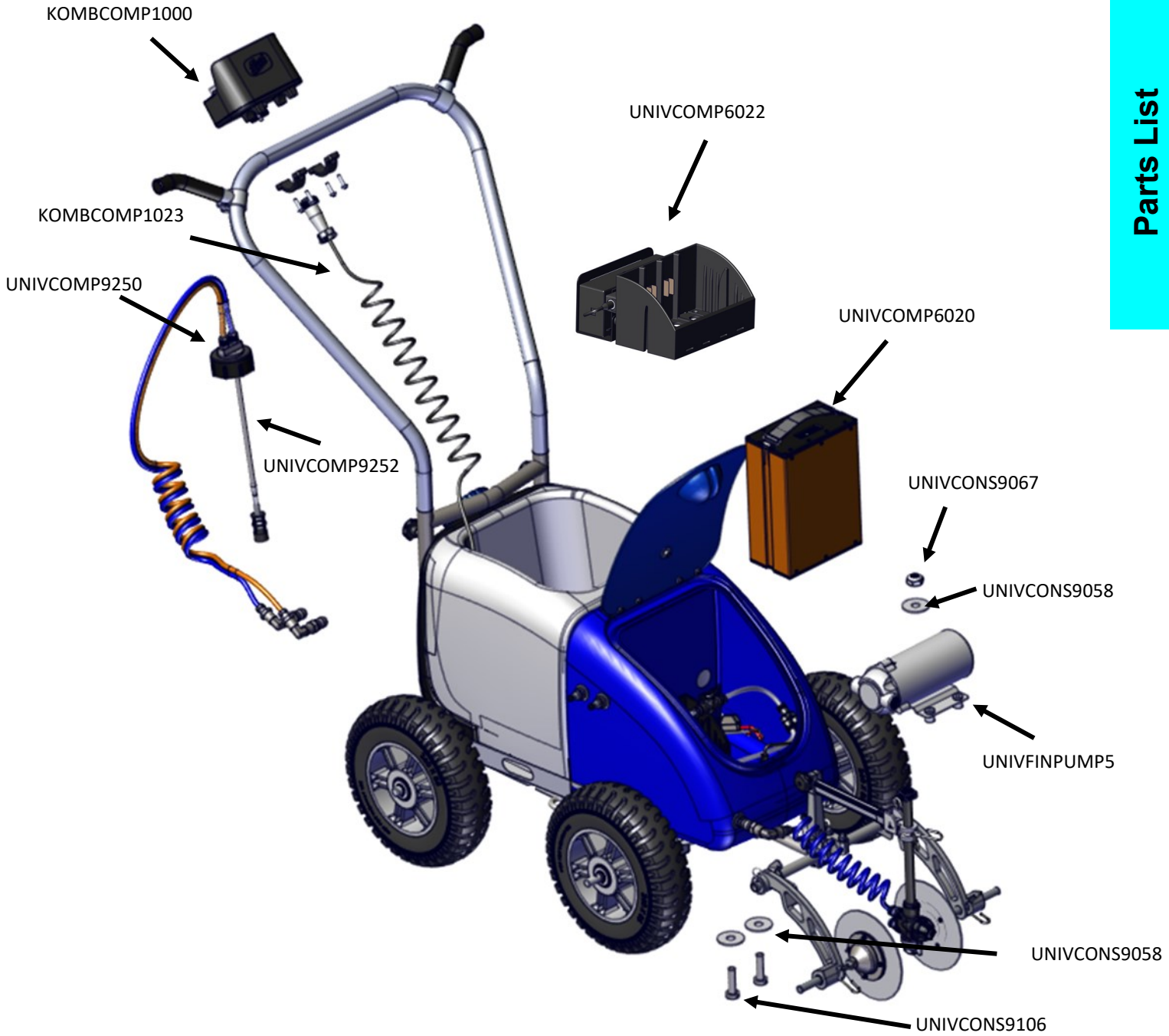

PART NO

PART NAME

KOMBCOMP1000	Kombi Ranger Control Panel
KOMBCOMP1023	Coiled Mains Cable
UNIVCOMP6020	Docking Battery
UNIVCOMP6022	Battery Charging Station
UNIVFINPUMP5	Diaphragm Pump
KOMBCOMP1226	Charge Socket
UNIVCONS9058	M6 x 20 Flat Repair Washer
UNIVCONS9067	M6 SS Hex Nyloc Nut
UNIVCONS9106	M6 x 40 Socket Cap Head Screw
UNIVCOMP9250	Ranger Draw Hose Plug
UNIVCOMP9252	Ranger Draw Hose Pipe

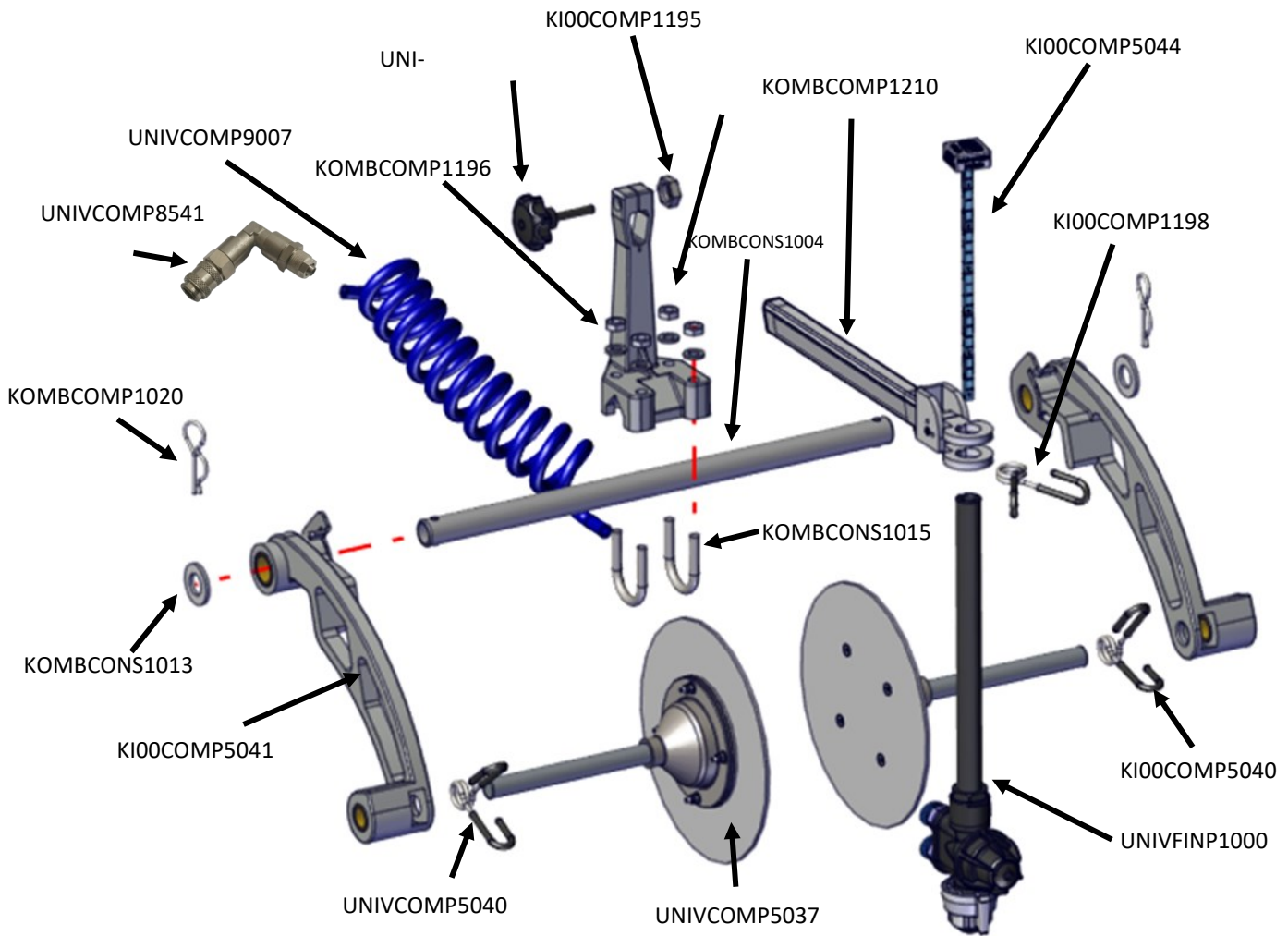

PART NO

PART NAME

UNIVCOMP5037	Guide Disc Enclosed Bearing
KI00COMP5040	Spring Collar
KI00COMP5041	Metal Guide Arms Set (Left & Right)
KI00COMP5044	Ruler Assembly
KI00CONS7012	M5 Hex Full Nut
KOMBCOMP1020	Steel R Clip
KOMBCOMP1196	Support Pillar
KOMBCOMP1198	Spring Clip 14mm
UNIVFINP1000	Flozle
KOMBCOMP1205	Wheeled Knib Standard
KOMBCOMP1210	Extruded Tube Assembly
KOMBCONS1004	M6 Form A Flat Washer
KOMBCONS1013	17.1mm ID x 30mm x 0.9mm Washer
KOMBCONS1015	M6 U Bolt (inc nuts)
UNIVCOMP9007	1m Coiled Blue Hose
UNIVCOMP9052	M5 x 25mm Hand Wheel Thumb Screw
UNIVCOMP8541	Quick Release Elbow Coupling

Specification

Machine

Length: 127cm Width: 74cm

Height: 109cm

Net Weight: 27kg

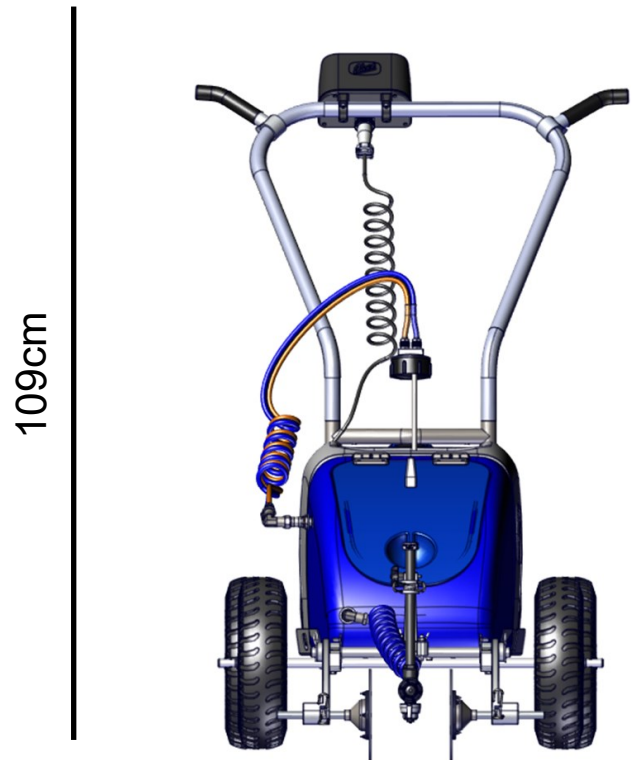
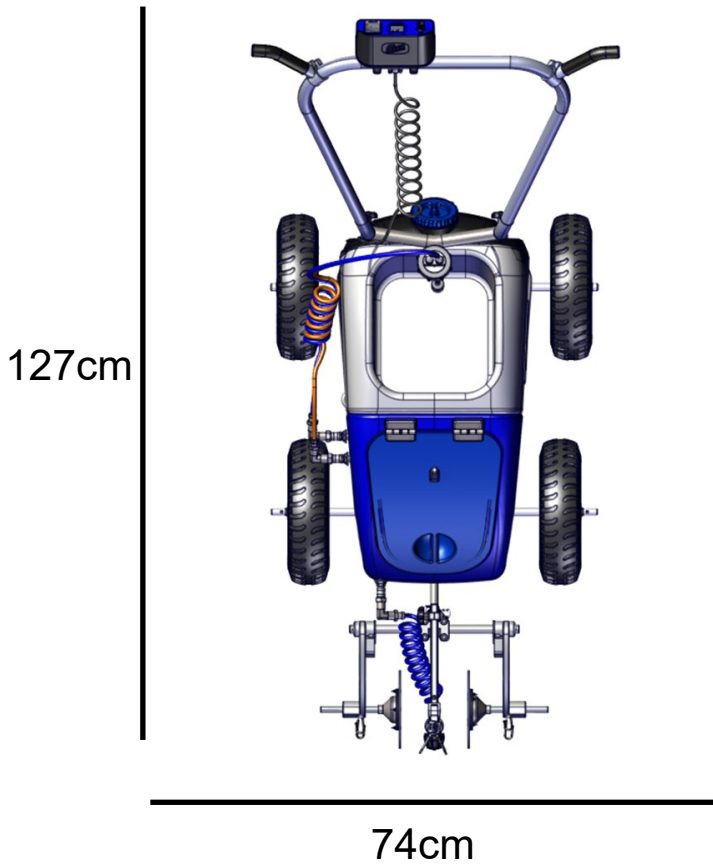

Package

Length: 77cm

Width: 64cm

Height: 57cm

Net Weight: 29kg

57cm

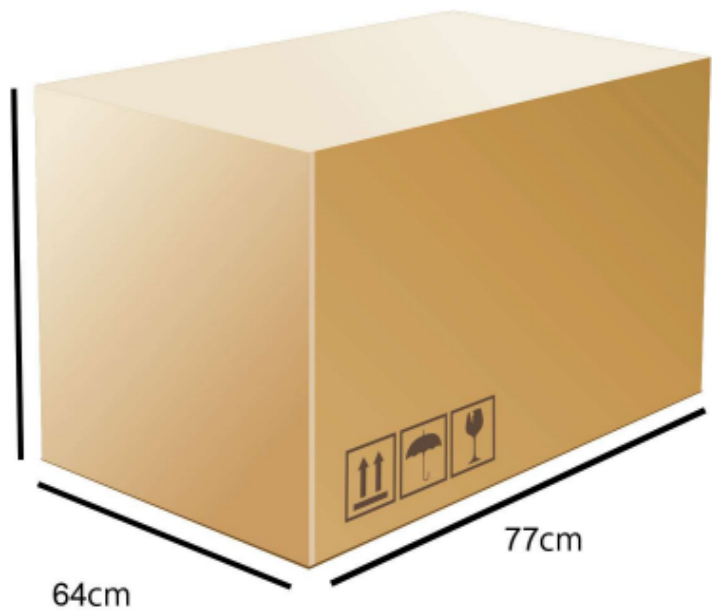

WARRANTY

The Kombi is capable of producing outstanding lines.

The Kombi pump has been matched for ultimate performance and reliability when used with Fleet paint.

The Kombi is guaranteed against any manufacturing defects. Any manufacturing defects will be corrected/replaced as soon as possible.

The Kombi is not guaranteed against normal wear and tear

This guarantee does not interfere with the customer's statutory rights.

The pump is guaranteed for 12 months when using Fleet paint. Machine must be registered by filling in the warranty card

Please fill out the table below for quick reference should you require.

Kombi Serial Number

Date Purchased:

Where Purchased: