

ROYAL DOULTON[®] ELITE

Filter Installation Instructions

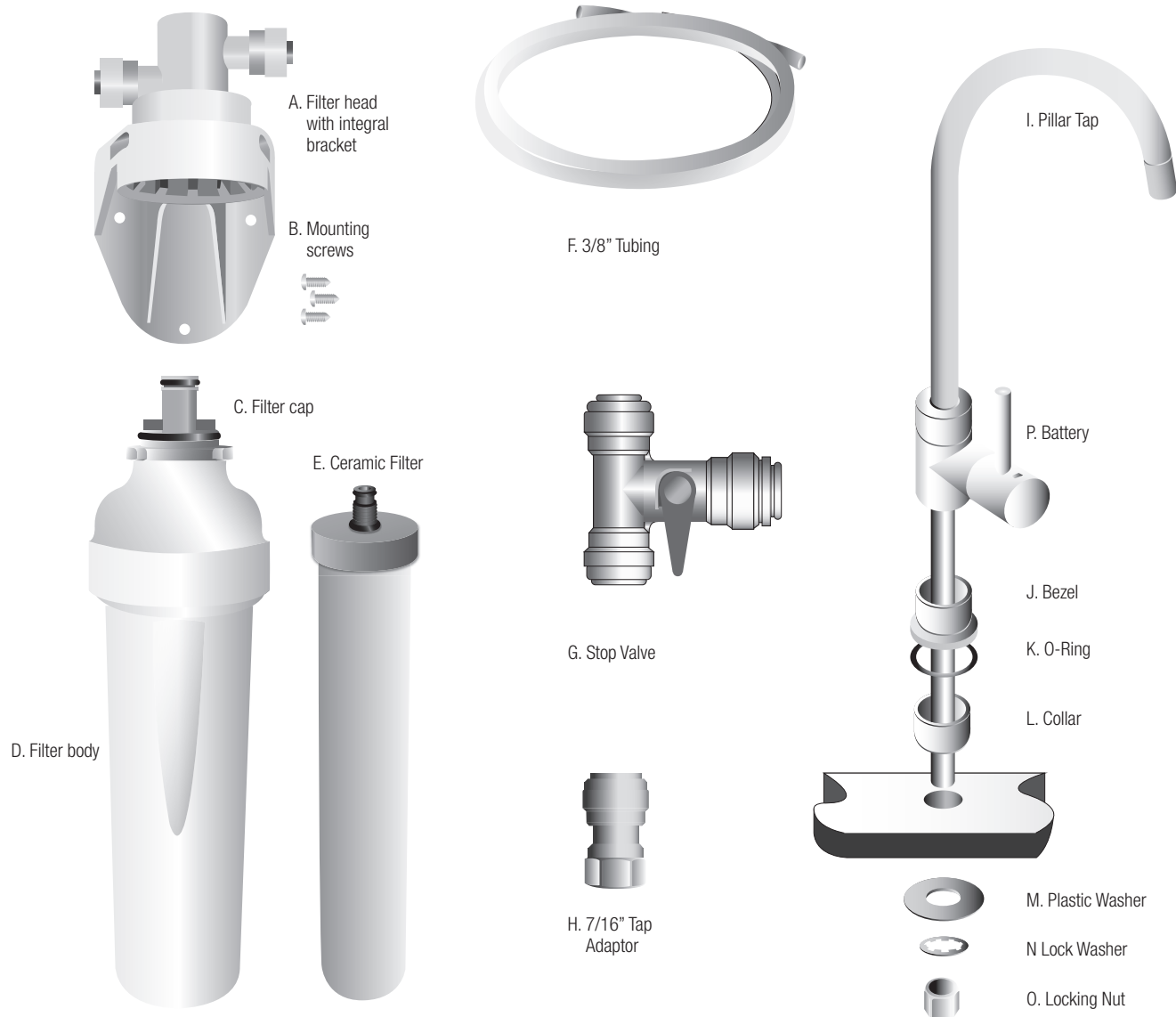

Parts included in your Elite Tap filtration system

Filter Housing Comprising:

- A. Filter Head
- B. Mounting Screws x3
- C. Filter Cap
- D. Filter Body
- E. Ceramic Filter

Fitting Kit:

- F. 3/8" Tubing
- G. Stop Valve
- H. 7/16" Tap Adaptor

Pillar Tap Comprising:

- I. Pillar Tap
- J. Bezel
- K. O-Ring
- L. Collar
- M. Plastic Washer
- N. Lock Washer
- O. Locking Nut
- P. CR 2032 3V Battery (fitted in the Pillar Tap)

1. Operating Conditions

- 1.1 Maximum Working Pressure: 6bar (90psi) - This filter has satisfied the NSF/ANSI Stds 42 and 53 structural test criteria. However, due to the potential wide variations of pressures from one installation to another, the manufacturer advises that if there is any concern that the system would see pressures above 6 bar then an approved pressure reducing valve set at 6 bar should be installed upstream of the filter to eliminate any extreme variations of pressure.
- 1.2 Maximum Working Temperature: 30°C (86°F)
- 1.3 Minimum Operating Pressure: 2bar (30psi)*
- 1.4 Minimum Operating Temperature: 5°C (41°F)
*This will result in a 1L/min flow of filtered water. At 45psi or greater, a flow rate of 1.5L/min or more will be seen

2. Important

- 2.1 This filter is intended for installation under the sink away from direct sunlight
- 2.2 This filter is not designed for the treatment of hot water and should only be connected to the cold water supply
- 2.3 Maximum plastic housing life: 10 years
- 2.4 Water fittings for use in permanently pressurised systems have a finite life. It is important that the plastic components in the system are replaced after 10 years usage
- 2.5 **PLEASE NOTE: Allowing the unit to freeze will invalidate the product warranty**

3. Location of the system and Preparation for Connecting Pipe work and Fittings

- 3.1 The filter is supplied with a Pillar Tap, stop valve, 3/8" push fit connections and 3/8" polyethylene tubing to allow connection to a 15mm mains pipe to supply cold filtered water to the pillar tap
- Note: If you have a different mains pipe you will need to obtain alternative fittings to adapt your existing pipe work to the 3/8" tube supplied with this system**
- 3.2 Choose a location next to your sink to install your new pillar tap. Ensure that there is enough space and access beneath the sink/work surface to allow installation of the tap fixings and filter pipe work
 - 3.3 Position the filter in an upright position near to the incoming mains cold water supply and the existing kitchen tap and new pillar tap
 - 3.4 Ensure that connecting pipe work will not have any sharp bends. Allow min 100mm (4") clearance below assembled filter for removal/service of the cartridge – see figure 1

Figure 1

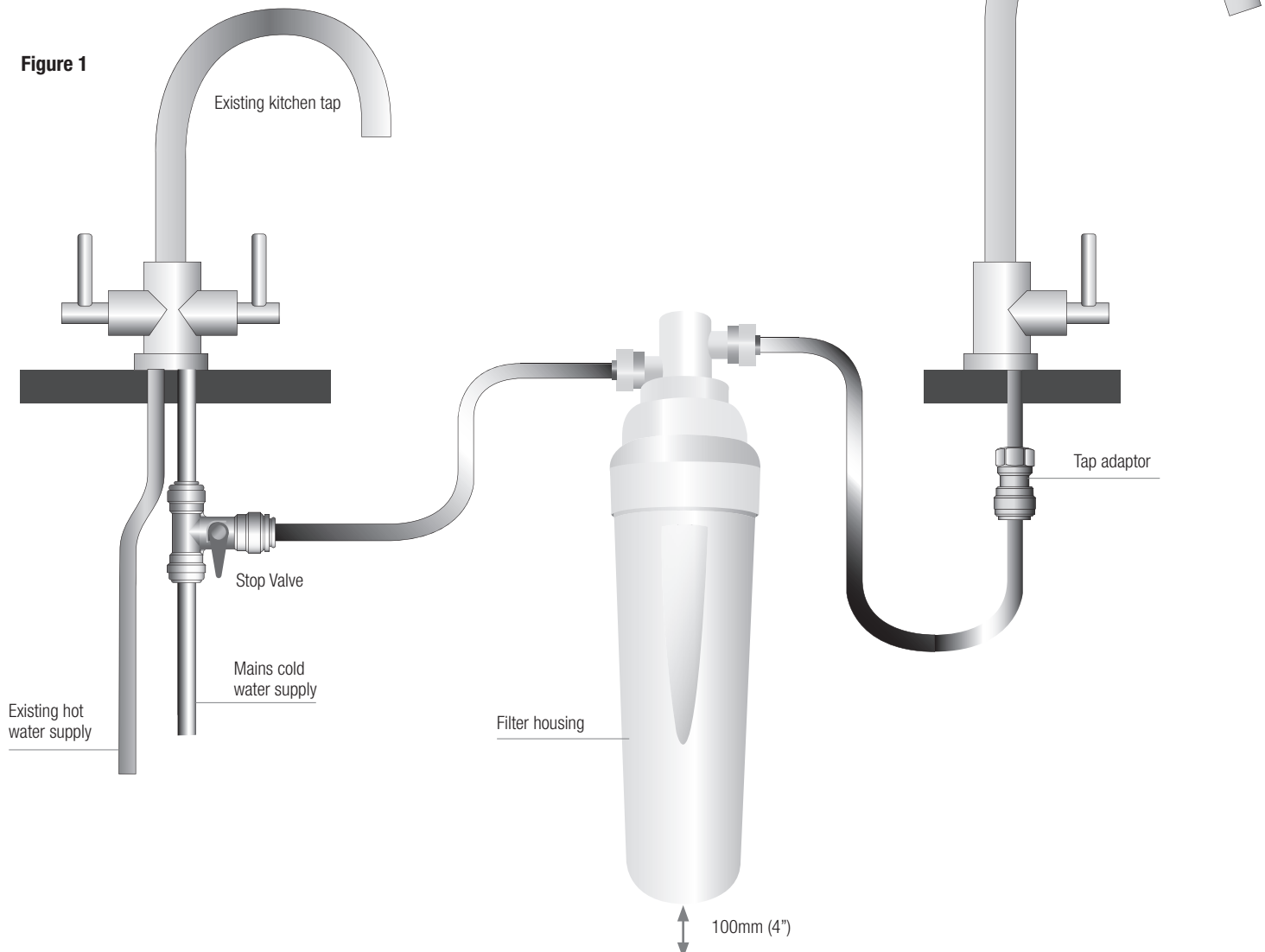

4. Install the Pillar Tap – see figure 2.

- 4.1 A \varnothing 12.5mm hole is required to mount the tap into the sink/work surface
- 4.2 Assemble the collar (L), bezel (J) and o-ring (K) over the tap stem and push into the tap body with the o-ring facing downwards. Insert the tap stem through the tap mounting hole
- 4.3 Beneath the sink/work surface, place the plastic washer (M) and lock washer (N) over the tap stem and secure the tap into position using the locking nut (O)
- 4.4 Screw the 7/16" tap adaptor (H) to the stem on your new pillar tap - do not over tighten

5. Install the stop valve to your cold water mains supply – see figure 3

- 5.1 Turn off your mains water supply
- 5.2 Install the 15mm to 3/8" stop valve (G) into the 15mm mains supply pipe to your existing kitchen tap. Choose a suitable location where the mains supply pipe can be cut to allow easy access to operate the stop valve once installed.
- 5.3 The stop valve allows push fit connection of the 15mm copper supply pipe, ensure that the ends of the copper are cut square and that there is no damage, dents or burrs. The copper pipe must be fully inserted into the stop valve connections.

The stop valve is only recommended to connect onto plastic, brass, copper or mild steel tubing and must only be used fully open or closed to ensure that the check valve works correctly.

NOTE: Do not use with stainless steel, chrome plated or other hard metal and polished metal tubes.

Figure 2

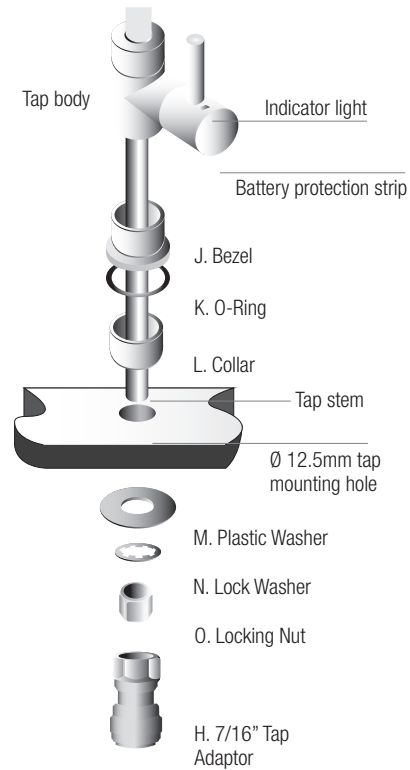
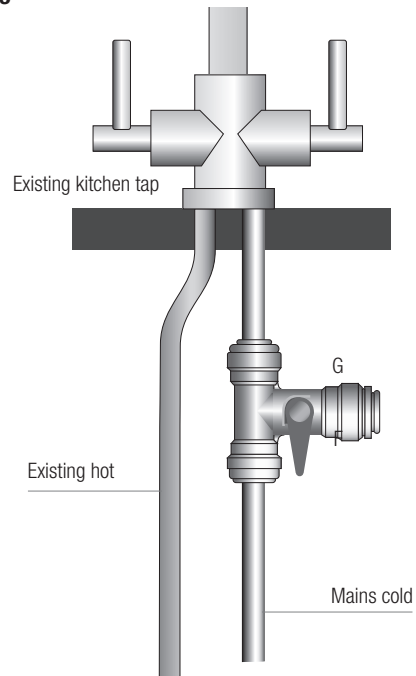

Figure 3



6. Position and Assemble the Filter – see figure 4a to 4d

6.1 Mark the required head position for fixing

Figure 4a

- 6.2 Grip the filter cap (C) and twist to the 'unlock' position
- 6.3 Pull down to disengage the filter cap (C) from the head (A) and put the filter cap (C) and filter body (D) to one side
- 6.4 Fix the filter head (A) to the unit or wall with the 3 screws (B) provided

Figure 4b

- 6.5 Unscrew the filter body (D) from the filter cap (C), open the filter and discard the protective bag from the ceramic filter (E)

Figure 4c

- 6.6 Screw the threaded ceramic filter (E) into the filter cap (C) until washer resistance is felt - do not over tighten
- 6.7 Screw the white filter body (D) into the filter cap (C) until a positive stop is felt

Figure 4d

- 6.8 Align the arrow on the filter cap (C) to the unlock position on the filter head (A) and push the assembled filter firmly into the head until it clicks into position
- 6.9 Twist the filter cap (C) until the arrow is aligned with the locked position on the filter head (A). Check that the arrows align to ensure that the filter is fully locked

7. Install the pipe work and stop valve – see figure 5

- 7.1 Measure and cut the tubing (F) to the length required to connect the inlet port of the filter head (A) to the stop valve (G) and outlet of the filter head (A) to the 7/16" adaptor (H)
- 7.2 Connect the stop valve (G) to the inlet port of the filter head (A) with the tubing (F). Ensure that the flow arrow on the stop valve (G) is pointing in the direction of the filter head (A)
- 7.3 Using the remaining cut tubing (F) connect the outlet port of the filter head (A) to the 7/16" adaptor (H) on the pillar tap (I).
- 7.4 Check that the arrows on the stop valve (G) and the ports of the filter head (A) are pointing in the correct direction of flow – towards your pillar tap (I) see figure 6

Figure 4a

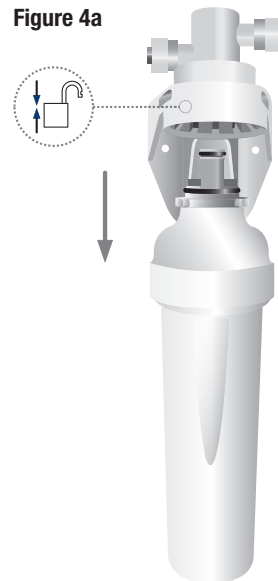

Figure 4b

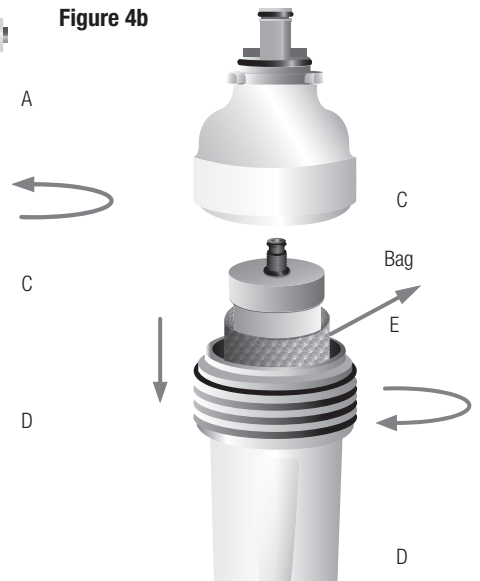

Figure 4c

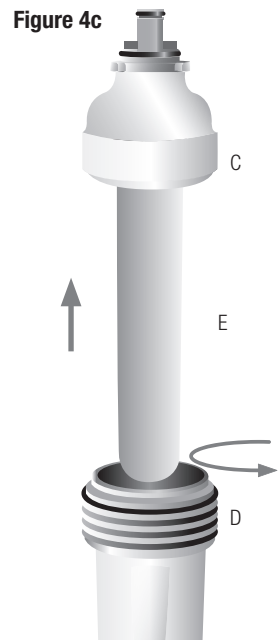

Figure 4d

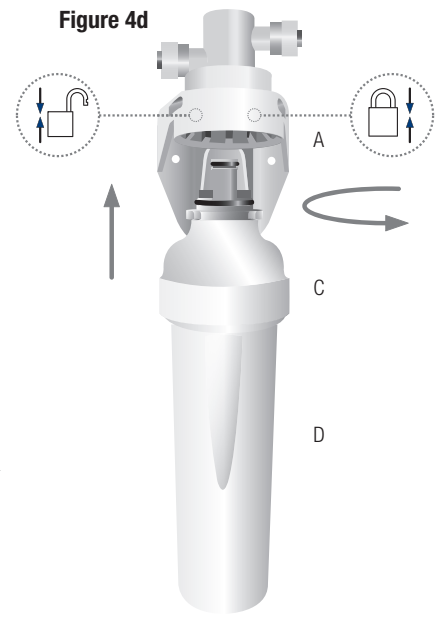

Figure 5

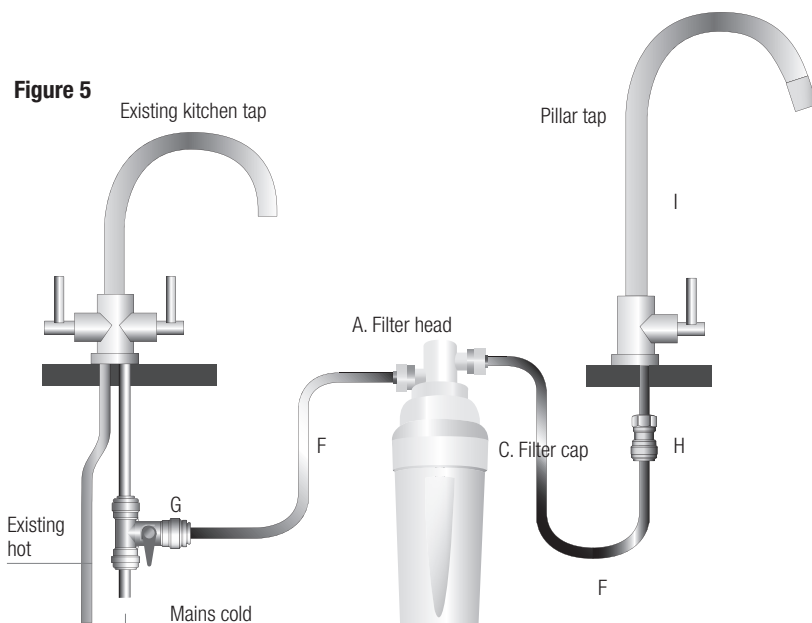
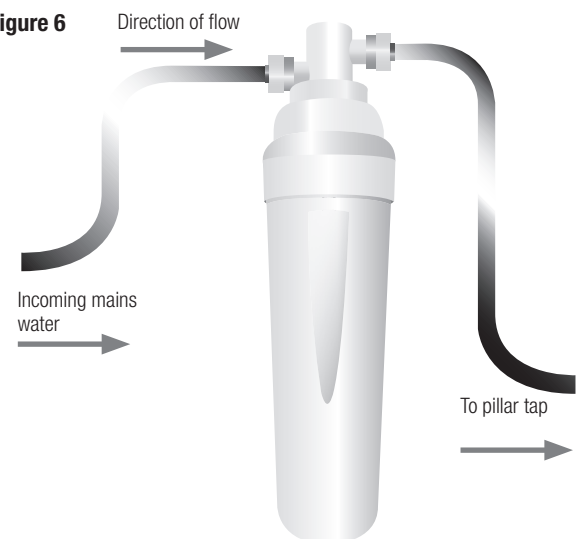

Figure 6



8. Check the system for leaks

For guidance on identification of system components see page 1 and figure 1

- 8.1 Turn on the mains water supply and with the pillar tap open, slowly open the stop valve to allow the system to fill gradually until all of the trapped air has been expelled from the system
- 8.2 Check for leaks around the stop valve, filter head inlet and outlet ports and pillar tap adaptor. Also check for leaks between the filter head, cap and filter body

8.3 If there are leaks from the push fitting on the stop valve or filter head ports:

- Turn off the mains water supply
- Open the pillar tap to release pressure from the system
- Press in on the collar around the tubing where it enters the push fitting, see figure 7
- Pull the tubing to release it from the push fitting
- Check to make sure that the tubing is cut square and that that it is not scratched or crimped
- If the tubing is unevenly cut or scratched, cut off the damaged section squarely and re install the tubing
- With the pillar tap open, slowly open the stop valve to allow the system to fill gradually again
- Check the system for leaks

Figure 7

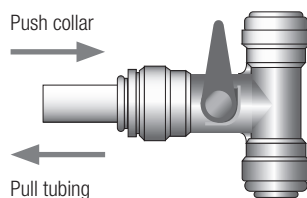
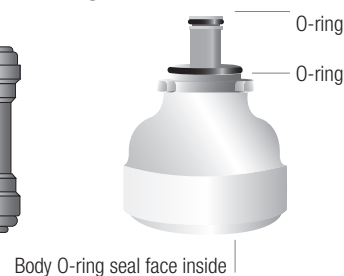

Figure 8



8.4 If there are leaks from the filter head:

- Turn off the mains water supply at the stop valve
- Open the pillar tap to release pressure from the system
- Remove the filter assembly, as described in section 6.2-6.3/figure 4a
- Check the O-rings around the top of the filter cap (C), ensure that they are in place and free from dirt and particles, see figure 8
- Re-fit the filter assembly, as described in section 6.8 -6.9/figure 4d
- With the pillar tap open, slowly open the stop valve to allow the system to fill gradually again
- Check the system for leaks

8.5 If there are leaks from the filter cap and filter body:

- Turn off the mains water supply at the stop valve
- Open the pillar tap to release pressure from the system
- Remove the filter assembly, as described in section 6.2-6.3/figure 4a
- Unscrew the filter body (D) from the filter cap (C)
- Check the O-ring around the top of the filter body, ensure it is in place and free from dirt and particles
- Remove the ceramic filter (E) by unscrewing from the filter cap (C) and place to one side ensuring that the open ended plastic mount is kept clean to avoid contamination

- Check the inside of the filter cap on the surface where the body O-ring seals, ensure it is free from dirt and particles, see figure 8
- Re fit the threaded ceramic filter and reassemble the filter as described in section 6.6 – 6.9/ figures 4c & 4d
- With the pillar tap open, slowly open the stop valve to allow the system to fill gradually again
 - Check the system for leaks

8.6 If there are leaks from the pillar tap adaptor:

- Turn off the mains water supply at the stop valve
- Open the pillar tap to release pressure from the system
- Press in on the collar around the tubing where it enters the adaptor
- Pull the tubing to release it from the 7/16" tap adaptor (H) and unscrew the adaptor from the stem of the pillar tap
- Check that the black sealing washer is correctly seated in the threaded hole of the tap adaptor
- Make sure the black sealing washer is undamaged and free from dirt and particles
- Screw the tap adaptor (H) to the stem of the pillar tap - do not over tighten
- Ensure sure that the tubing is cut square and it is not scratched or crimped
- If the tubing is unevenly cut or scratched, cut off the damaged section squarely and re install the tubing
- With the pillar tap open, slowly open the stop valve to allow the system to fill gradually again
- Check the system for leaks

9. Prepare the filter for use

- 9.1 The pillar tap (I) has an indicator light to inform the user when the ceramic filter requires changing. The light flashes 'blue' when the filtered water tap is operated, if the light flashes 'red' the ceramic filter requires changing. Remove the plastic battery protection strip from the underside of the pillar tap operating lever to enable the filter replacement indicator function, see figure 2
- 9.2 Open the pillar tap and run the water to waste for 10 minutes (or 20 litres)
- 9.3 Leave to stand for 24 hours to condition the ceramic filter, then run water to waste for a further 10 minutes. The filter is now ready for use

10. Care and Cleaning

- 10.1 Use only soapy water and a soft sponge or cloth to clean the filter housing and pillar tap, avoid the use of:
 - Strong oxidising agents such as bleach or Milton solution
 - All strongly acidic materials including descalents
 - Strongly alkaline materials
- 10.2 Always ensure that the filter housing and pillar tap are thoroughly rinsed and dried after cleaning
- 10.3 If used with hard water or water with very high mineral content it is necessary to clean and dry the pillar tap after use, build up of calcium and other minerals could seriously damage the surface of the tap

11. Servicing/Replacing the ceramic filter (E) – see figure 9

- 11.1 Grip the textured rim of the filter cap (C), twist to the 'unlock' position, taking care not to trap fingers and pull down to disengage.

Note: If the filter has had little use prior to servicing, twist the filter cap (C) to the 'V' vent position and open the pillar tap (to relieve pressure in the filter) twist the cap to the 'unlock' position and pull down to disengage the filter whilst the pillar tap remains open

- 11.2 The water supply is automatically turned off when the filter is dismantled.
Note: If the filter is to be left unattended whilst dismantled for an extended period of time (i.e. over 1 hour) then the upstream mains water supply should be turned off
- 11.3 Take the filter cartridge to the sink – remembering that it is still full of water
- 11.4 Unscrew the filter cap (C) to remove the filter body and empty the water into the sink, **taking care not to contaminate the open ended neck of the filter cap with unfiltered water**
- 11.5 Unscrew the ceramic filter (E) from the filter cap (C). **Note: Care must be taken to prevent contamination of the neck of the filter cap and ceramic filter mount stem**
- 11.6 Replace ceramic filter or clean as described in section 12 and then wash your hands. **Note: If replacing with a new ceramic filter, prepare the filter for use as described in section 9 or as per the Operating and Exchange Instructions supplied with the replacement ceramic filter and replace the battery in the pillar tap**
- 11.7 The used ceramic filter can be wrapped in a plastic bag or newspaper for disposal with your household waste

Figure 9

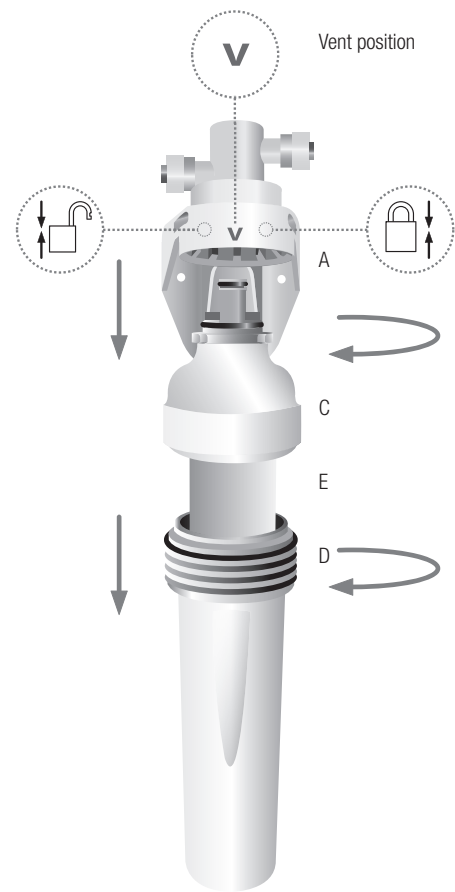

12. Cleaning the ceramic filter – see figure 10

Due to filtration of particulate contaminants from the water during use, the flow of water from the filter may reduce over a period of time. To restore flow to its normal level simply clean the ceramic filter as follows:

- 12.1 Hold the ceramic filter in a bowl of water or under running water. Ensure that the open ended plastic mount is clear of the water to avoid contamination
- 12.2 Take a clean kitchen scouring pad in one hand and cup it around the circumference of the ceramic filter at the top next to the mount. Press gently onto the ceramic filter surface with the scouring pad, whilst quickly turning the filter with the other hand
- 12.3 Apply a gentle even pressure with the pad and slowly work down the length of the ceramic filter once. Ensure that the cleaning is uniform over the whole filter

Figure 10

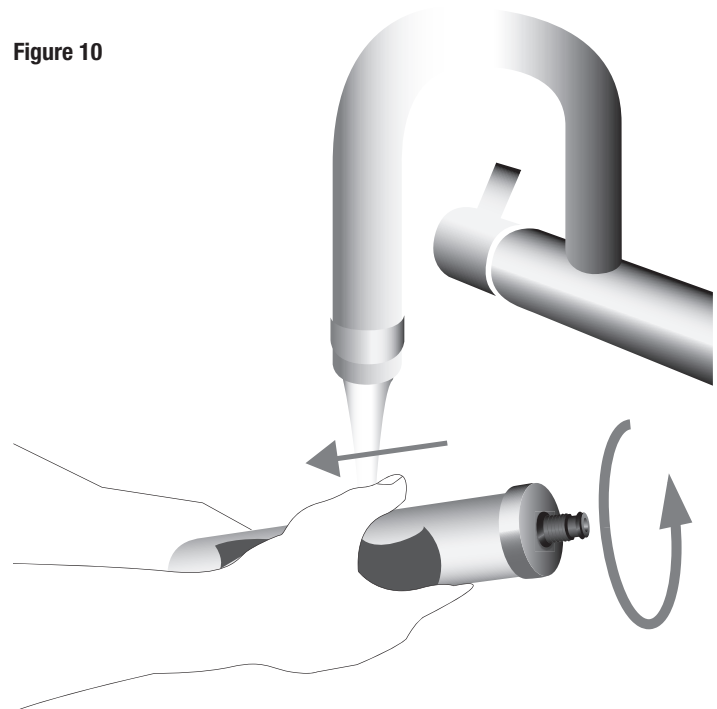

13. Changing the battery – see figure 11

When the ceramic filter has been changed the Pillar Tap indicator light will need to be re-set. To re-set the indicator light, follow the steps below.

- 13.1 Remove the battery holder by pulling out from the underside of the pillar tap operating lever
- 13.2 Remove the battery
- 13.3 Re fit a new CR 2032 3V battery. The LED light on the circuit board will flash red then blue
- 13.4 Push the battery holder into the underside of the pillar tap operating lever, ensure the light on the circuit board aligns with the light lens. The indicator light is now re-set for use with the new ceramic filter, when the pillar tap is operated the indicator light flashes 'blue'

Parts and Service Availability - Buy online at www.doulton.com

Product Warranty - Your filter housing is covered under warranty for 12 months from the purchase date of the product against any failure due to defect of materials, workmanship or design of the filter housing. Please retain your receipt as proof of purchase. To register your product warranty please visit www.doulton.com/product-registration/ and complete the Product Registration Form.

Extended Product Warranty via the Doulton App

Download the Doulton® App and register your filter housing for a further 12 months free product warranty. The App can also be used to check the service life remaining on your ceramic filter, remind you when it is time to replace and allow you to easily order replacement filters.

Figure 11

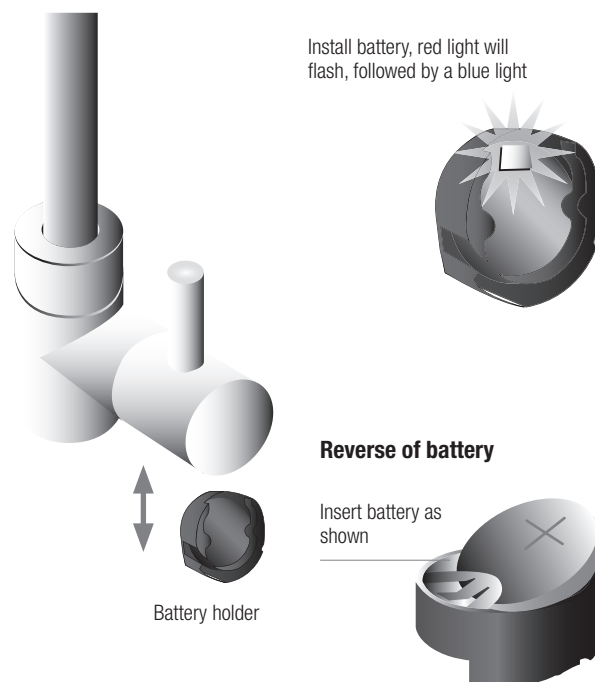

Manufactured by:

Doulton Water Filters, Newcastle, Staffordshire, ST5 9BT, United Kingdom.

Telephone: +44 (0) 1782 664420

Fax: +44 (0) 1782 664490

Email: filtersales@doulton.com

Website: www.doulton.com

Royal Doulton® is a trademark registered to Fairey Industrial Ceramics Ltd.

