

RNWO, RWNVOV



Renaissance® 27" and 30" Wide Double Wall Ovens

PLANNING GUIDE

Product tolerances: ±1/16" (±1.6 mm) unless otherwise stated

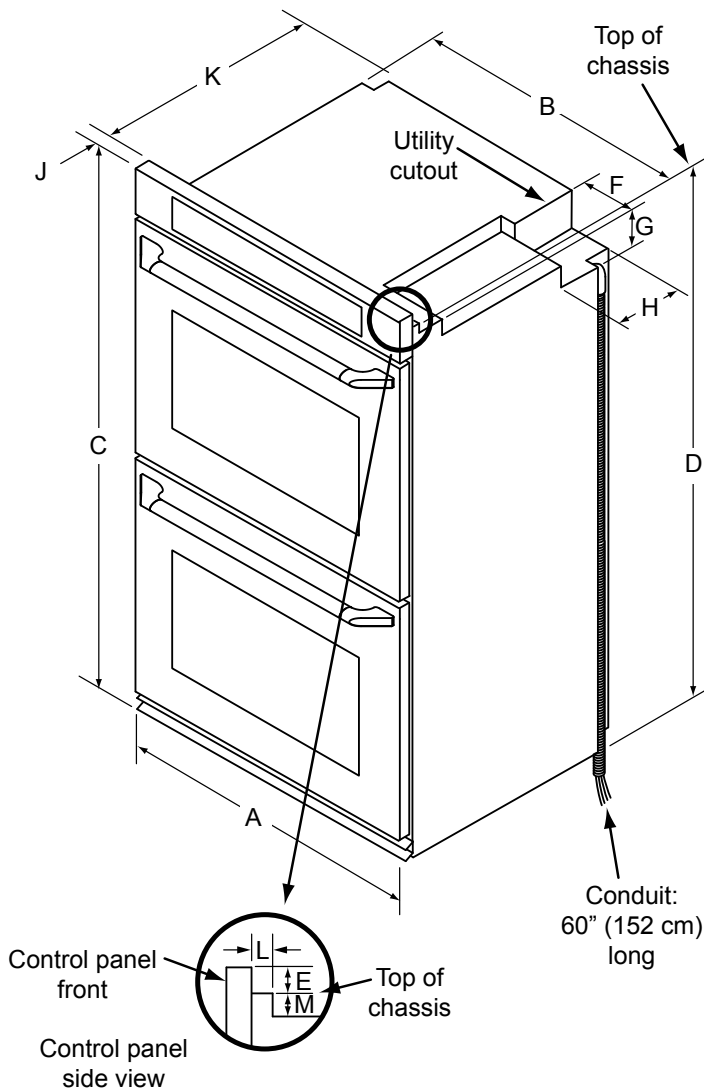

⚠ WARNING

- Observe all governing codes and ordinances during planning and installation. Contact your local building department for further information.
- This appliance must be installed in accordance with the accompanying installation instructions.

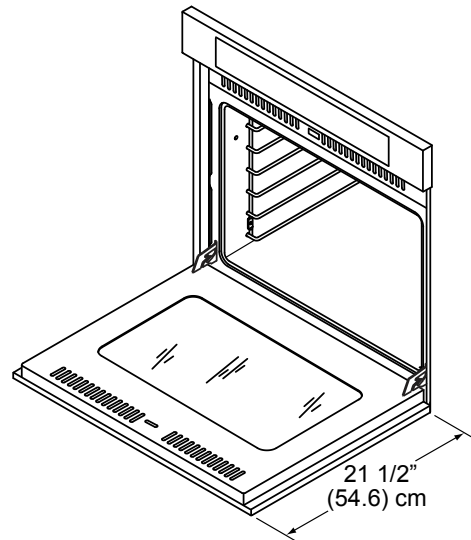

ELECTRICAL SPECIFICATIONS		
Model	Dedicated Circuit Requirements	Total Connected Load
RNWO[V]227	240 Vac 60 Hz., 4-wire,*** 40 Amp.	240 Vac 60 Hz, 39.4 Amp., 9.5 kW
RNWO[V]230	240 Vac 60 Hz., 4-wire,*** 50 Amp.	240 Vac 60 Hz, 48.6 Amp., 12.0 kW

*** Two 120 Vac hot (L1 and L2), one neutral, one ground

The above specifications are for reference only. See the appliance data plate for exact specifications.

Model	(A) Overall Width	(B) Chassis Width	(C) Overall Height	(D)* Chassis Height	(E) Control Panel Overlay
RNWO[V]227	26 7/8" (68.3 cm)	25 1/2" (64.8 cm)	50 1/8" (127.3 cm)	49 3/4" (126.4 cm)	3/8" (1.0 cm)
RNWO[V]230	29 7/8" (75.9 cm)	28 1/2" (72.4 cm)	50 1/8" (127.3 cm)	49 3/4" (126.4 cm)	3/8" (1.0 cm)

* To top of chassis notch behind control panel

(F) Utility Cutout Width	(G) Utility Cutout Height	(H) Utility Cutout Depth	(J) Control Panel Depth	(K) Chassis Depth	(L) Control Panel Notch Depth	(M) Notch Height
6 1/2" (16.5 cm)	5" (12.7 cm)	7 7/8" (20.0 cm)	3/4" (1.9 cm)	24" (61.0 cm)	1/2" (1.3 cm)	3/4" (1.9 cm)



RNWO, RNWOV



Renaissance 27" and 30" Wide Double Wall Ovens

PLANNING GUIDE

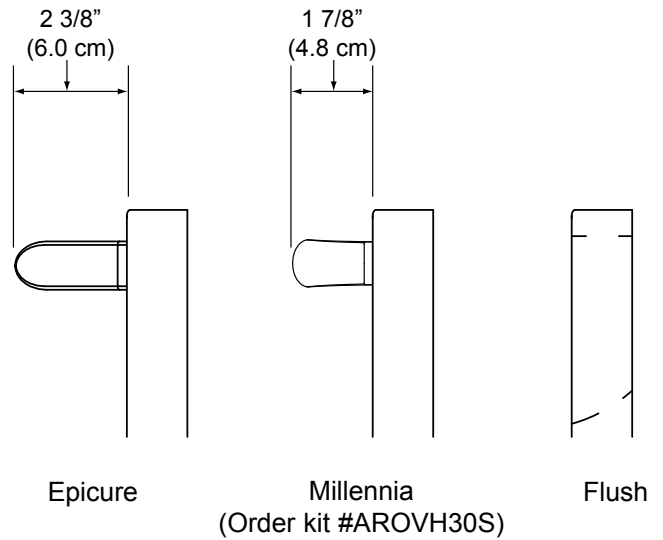
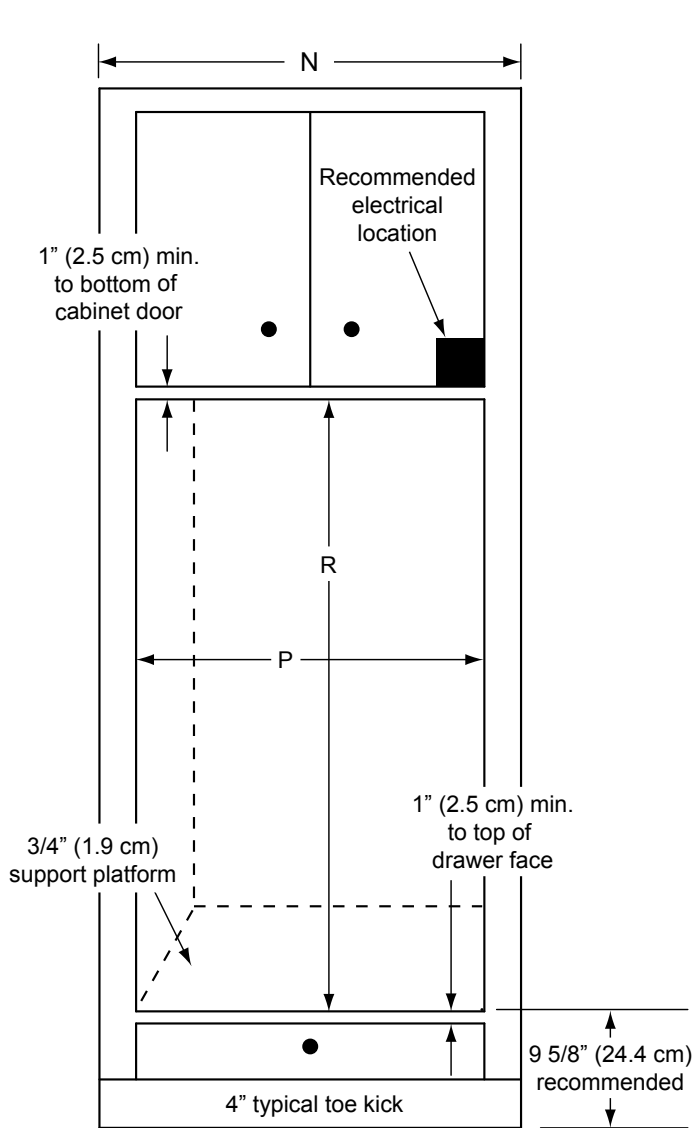

Handle Dimensions

DOUBLE WALL OVEN - CUTOUT DIMENSIONS

Model	(N) Minimum Cabinet Width	(P) Cut Out Width	(R) Minimum Cutout Height
RNWO[V]227	27" (68.6 cm)	25 5/8" (65.1 cm) minimum (recommended) 26 1/8" (66.4 cm) maximum	49 7/8" (126.7 cm)
RNWO[V]230	30" (76.2 cm)	28 5/8" (72.7 cm) minimum (recommended) 29 1/8" (74.0 cm) maximum	49 7/8" (126.7 cm)

Minimum interior cabinet depth: 24" (61.0 cm)

RNWO, RNWOV



Renaissance 27" and 30" Wide, Double Wall Oven

PLANNING GUIDE

CUTOUT DIMENSIONS - FLUSH INSTALLATION DOUBLE WALL OVEN

Cabinet tolerances: +1/16" (+1.6 mm) -0, unless otherwise stated

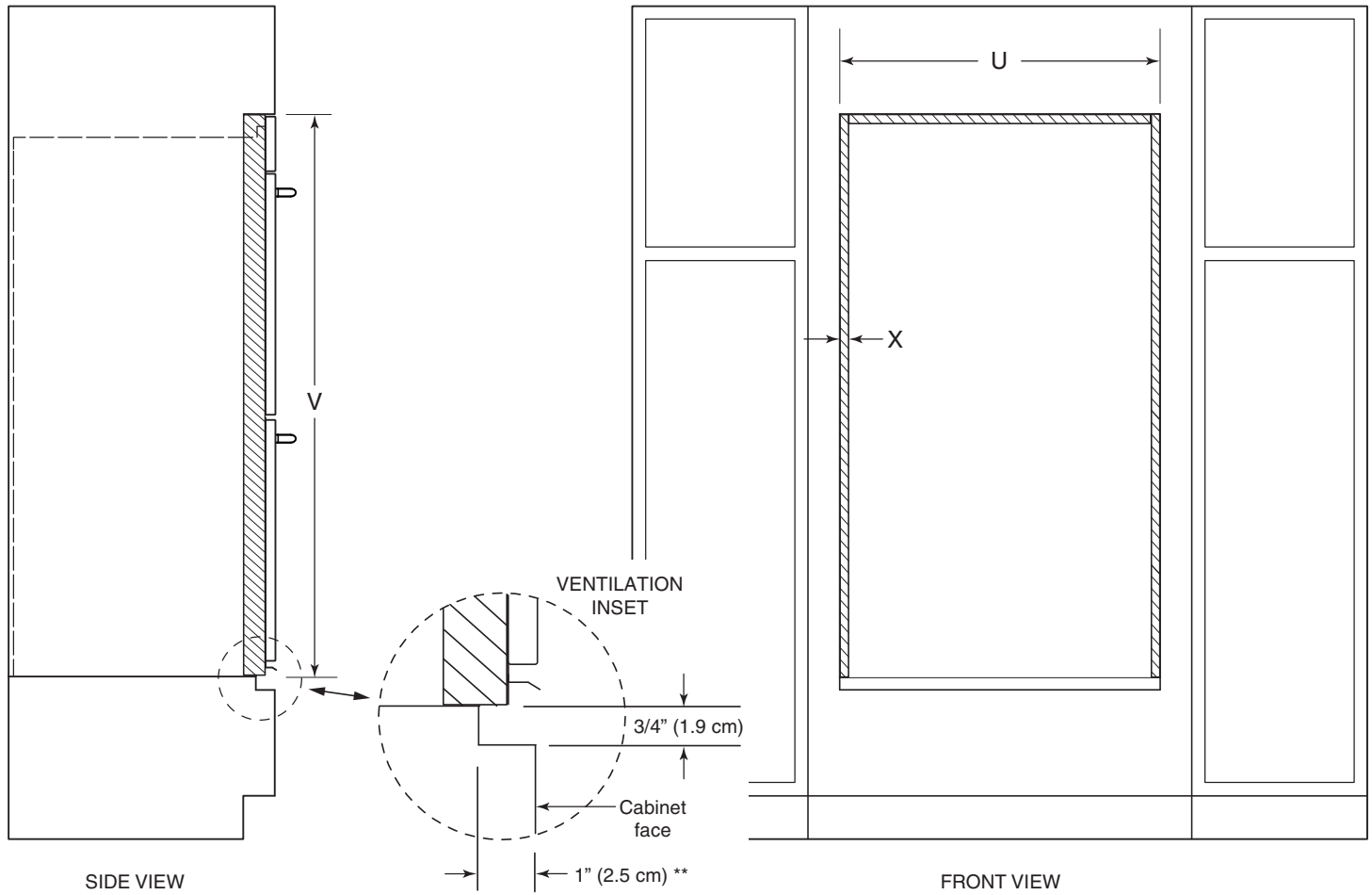
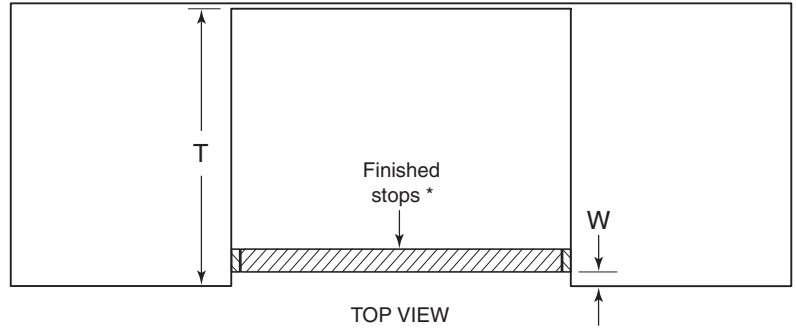

** 1 1/8" (2.9 cm) for models
RNWO[V]227B, RNWO[V]230B,
RNWO227W, RNWO230W

Model	(T) Minimum Cabinet Depth	(U) Cutout Width	(V) Cutout Height	(W) Stop Depth	(X) Stop Width
RNWO227[F]S	24 3/4" (62.9 cm)	27" (68.6 cm)	49 7/8" (126.7 cm)	3/4" (1.9 cm)	3/8" (1.0 cm)
RNWO230[F]S	24 3/4" (62.9 cm)	30" (76.2 cm)	49 7/8" (126.7 cm)	3/4" (1.9 cm)	3/8" (1.0 cm)
RNWO[V]227B, RNWO227W	24 7/8" (63.2 cm)	27" (68.6 cm)	49 7/8" (126.7 cm)	7/8" (2.2 cm)	3/8" (1.0 cm)
RNWO[V]230B, RNWO230W	24 7/8" (63.2 cm)	30" (76.2 cm)	49 7/8" (126.7 cm)	7/8" (2.2 cm)	3/8" (1.0 cm)

* Back of wall oven control panel rests against stops