



# 30-INCH EPICURE DUAL-FUEL RANGE

HDER30 | HERITAGE COLLECTION



## AVAILABLE MODELS

|              |   |
|--------------|---|
| HDER30/NG    | 30" Heritage Dual Fuel Epicure Range - Stainless Steel Natural Gas                  |
| HDER30/LP/H  | 30" Heritage Dual Fuel Epicure Range - Stainless Steel Liquid Propane High Altitude |
| HDER30/LP    | 30" Heritage Dual Fuel Epicure Range - Stainless Steel Liquid Propane               |
| HDER30/NG/H  | 30" Heritage Dual Fuel Epicure Range - Natural Gas High Altitude                    |
| HDER30C/NG/H | 30" Heritage Dual Fuel Epicure Range - Color Match Natural Gas High Altitude        |
| HDER30C/NG   | 30" Heritage Dual Fuel Epicure Range - Color Match Natural Gas                      |
| HDER30C/LP/H | 30" Heritage Dual Fuel Epicure Range - Color Match Liquid Propane High Altitude     |
| HDER30C/LP   | 30" Heritage Dual Fuel Epicure Range - Color Match Liquid Propane                   |

## FEATURES & BENEFITS

- Exclusive Four-Part Pure Convection – heating element, air baffle, fan and filter to precisely distribute heat for superior cooking results.
- Large oven capacity - 5.2 cu. ft.
- 4 Dual-Stack Sealed Burners.
- Powerful 18K BTU and true simmer burners.
- Illumina™ Knobs - White LED
- LED Tilt-View™ Glass Touch Control
- Soft Close Oven Door
- Continuous Grate Platform
- All Brass Valves, Heads and Caps

## ADDITIONAL FEATURES

|                |                        |
|----------------|------------------------|
| CLEANING TYPE  | SELF CLEAN GREENCLEAN™ |
| TYPE OF GRATE  | CONTINUOUS CAST IRON   |
| CAVITY         | BLACK ENAMEL COATING   |
| RACK POSITIONS | 6                      |
| LIGHTING       | LED & HALOGEN          |

## GENERAL PROPERTIES

|                            |  |
|----------------------------|--|
| OVEN CAPACITY (CUBIC FEET) | 5.2 CU FT.   |
| COOKING MODES              | PURE CONVECTION™<br>CONVECTION BAKE<br>CONVECTION BROIL<br>CONVECTION ROAST<br>BAKE<br>BROIL |

## OVEN PERFORMANCE

|                    |                 |
|--------------------|-----------------|
| BAKE ELEMENT       | 3,000W - 8 PASS |
| BROIL ELEMENT      | 3,500W - 8 PASS |
| CONVECTION ELEMENT | 2,200W          |

## BURNER PERFORMANCE

|                                 |                            |
|---------------------------------|----------------------------|
| TOTAL NUMBER OF COOKTOP BURNERS | 4 DUAL STACK BRASS BURNERS |
| LEFT FRONT (BTU)                | 18,000 DUAL (SIMMER/SEAR)  |
| LEFT REAR (BTU)                 | 15,000 STACK DUAL (SIMMER) |
| RIGHT FRONT (BTU)               | 15,000 STACK DUAL (SIMMER) |
| RIGHT REAR (BTU)                | 15,000 STACK DUAL (SIMMER) |
| SEALED BURNERS                  | YES                        |
| PERMA-FLAME™ (AUTO RE-IGNITION) | YES                        |

## ADDITIONAL MODES

|                   |     |
|-------------------|-----|
| KEEP WARM         | YES |
| PROOF             | YES |
| TEMPERATURE PROBE | YES |
| DEHYDRATE         | YES |
| SABBATH           | YES |

## CONTROL FEATURES

|                           |                         |
|---------------------------|-------------------------|
| LED (WHITE)               | YES                     |
| NUMBER OF KNOBS           | 4 KNOBS                 |
| CONTROL METHOD            | LED GLASS TOUCH CONTROL |
| ILLUMINA™ BURNER KNOBS    | YES                     |
| HIGHLIGHTING COLOR        | WHITE                   |
| CLOCK                     | YES                     |
| DELAY START               | YES                     |
| KITCHEN TIMER             | YES 2                   |
| TIME OF DAY (12 HR/24 HR) | YES                     |
| TEMPERATURE (F/C)         | YES                     |
| CHILD LOCK                | YES                     |
| SOUND ON/OFF              | YES                     |

## TECHNICAL DETAILS

|                     |  |
|---------------------|--|
| CIRCUIT BREAKER (A) | 40 AMP   |
| VOLTS (V)           | 240 V  |
| FREQUENCY (HZ)      | 60 HZ  |
| ENERGY SOURCE       | GAS AND ELECTRICAL   |
| GAS TYPES           | NATURAL GAS<br>NATURAL GAS (HIGH ALTITUDE)<br>LIQUID PROPANE<br>LIQUID PROPANE (HIGH ALTITUDE) |

## DIMENSIONS & WEIGHT

|  |                             |
|--|-----------------------------|
| APPLIANCE DIMENSIONS (H X W X D) (IN.) | 30 1/8" X 29 7/8" X 26 7/8" |
| REQUIRED CUTOUT SIZE (W X D) (IN.)     | 30" X 24"                   |

## WARRANTY

|                          |        |
|--------------------------|--------|
| LIMITED, PARTS AND LABOR | 1 YEAR |
|--------------------------|--------|

### APPLIANCE DIMENSIONS

30"

|            |                                 |
|------------|---------------------------------|
| A (WIDTH)  | 29 7/8" (75.9CM)                |
| B (DEPTH)  | 24" (60.1CM)                    |
| C (HEIGHT) | 30 3/16 TO 37 1/2 (91.9-95.3CM) |

Product tolerances: +/- 1/6" (+/-1.6MM)

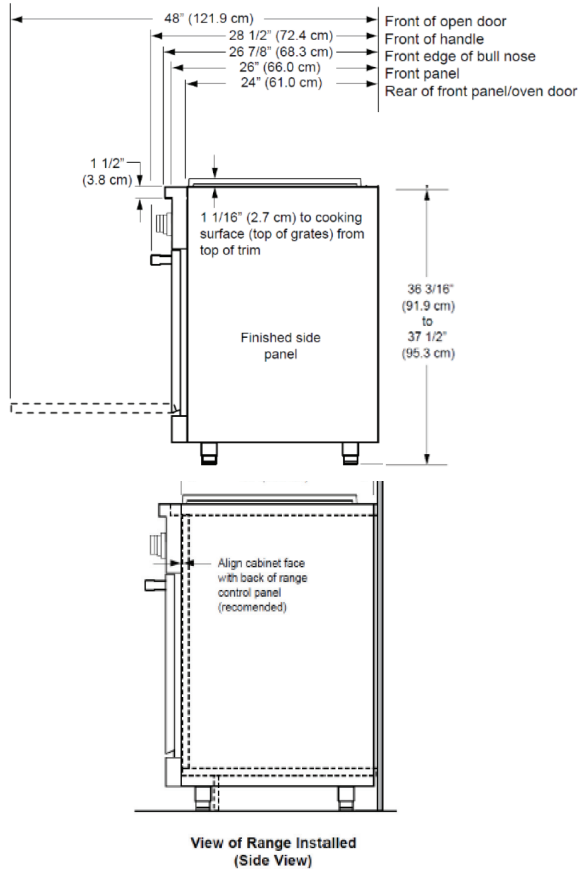

### CABINET CUT-OUT DIMENSIONS

| RANGE MODEL | F                                 | G                  |
|-------------|-----------------------------------|--------------------|
| HDER30      | 36" (91.4 CM)*<br>30" (76.2 CM)** | 30"<br>(76.2 CM)** |

\* Recommended  
\*\* Minimum

Cutout tolerances: +1/16" (+1.6 mm), -0 unless otherwise stated

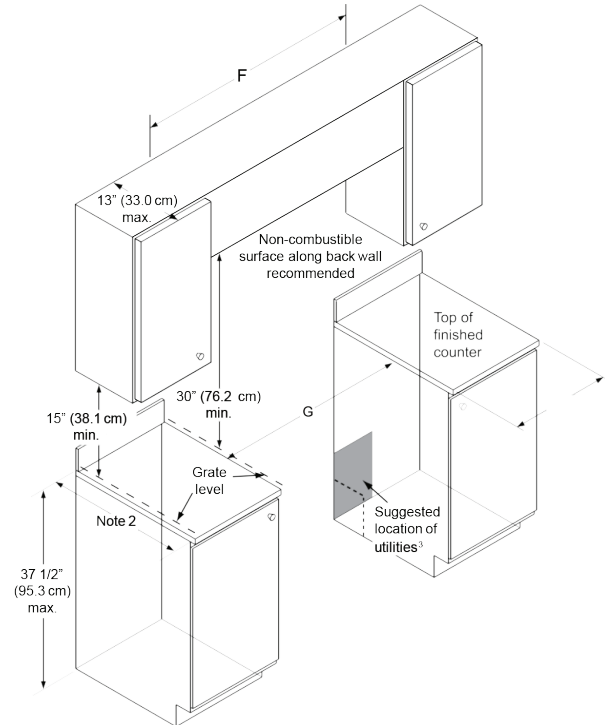

### ACCESSORIES (INCLUDED)

|                                   |      |
|-----------------------------------|------|
| GLIDERACK™                        | 2    |
| STANDARD RACK                     | 1    |
| TEMPERATURE PROBE                 | 1    |
| WOK RING                          | 1    |
| CONVECTION FILTER                 | 1    |
| BRASS/BLACK PORCELAIN BURNER CAPS | 6/EA |
| REMOVABLE NON-STICK GRIDDLE       | 1    |

### ACCESSORIES (OPTIONAL)

|   |          |
|---|----------|
| COOKIE SHEETS (SET OF 3)                              | ACSRO303 |
| REMOVABLE NON-STICK GRIDDLE                           | AG30     |
| REMOVABLE NON-STICK SEARING GRILL                     | AEGR30   |
| BAKING STONE  | ABS16    |
| BROIL/ROASTING PAN W/GRILL & V RACK                   | AORPVR   |
| STAINLESS STEEL BACKGUARD, MOUNTS TO UNIT (6 IN HIGH) | AHB30D6  |
| STAINLESS STEEL BACKGUARD, MOUNTS TO UNIT (9 IN HIGH) | AHB30D9  |
| 3" SIDE PANELS  | ARSP3    |