

Table of Contents

Important Safety Instructions.....	1
Getting to Know the Cooktop.....	3
Setting Up the Cooktop.....	4
Operating the Cooktop.....	6
Care and Cleaning.....	8
Troubleshooting.....	10
Warranty and Service.....	10
Warranty Card.....	Back Cover





To Our Valued Customer:

Congratulations on your purchase of the very latest in Dacor® products! Our unique combination of features, style, and performance make us a great addition to your home.

To familiarize yourself with the controls, functions and full potential of your new Dacor cooktop, read this manual thoroughly, starting with **Important Safety Instructions** (Pg. 1).

Dacor appliances are designed and manufactured with quality and pride, while working within the framework of our company values. Should you ever have an issue with your cooktop, first check **Troubleshooting** (Pg. 10) for suggestions and remedies that may pre-empt a call for service.

Valuable customer input helps us continually improve our products and services, so feel free to contact our Customer Assurance Team for assistance with all your product-support needs.

Dacor Customer Assurance
14425 Clark Avenue
City of Industry, CA 91745

Telephone: 833-35-ELITE (833-353-5483) USA, Canada

Fax: (626) 403-3130

Hours of Operation: Mon – Fri, 5:00 a.m. to 5:00 p.m. Pacific Time

Website: www.dacor.com/customer-care/contact-us

Thanks for choosing Dacor for your home. We are a company built by families for families, and we are dedicated to serving yours. We are confident that your new Dacor cooktop will deliver a top-level performance and enjoyment for decades to come.

Sincerely,

The Dacor Customer Assurance Team

Important Safety Instructions

Installer

Leave these instructions with the unit.

Consumer

Before using the cooktop, read this manual fully, and save it for personal and professional reference. Keep your sales receipt or canceled check. Proof of original purchase date is needed for warranty service. (For service/warranty information, see Pg. 10.)

If you have any questions call:

Dacor Customer Assurance

833-353-5483 (USA, Canada)

Mon – Fri, 5:00 a.m. to 5:00 p.m. Pacific Time

Website: www.dacor.com/customer-care/contact-us

When you call, have available the cooktop model and serial numbers, which are on the data label on the chassis bottom. For easy access, record these numbers here:

Model Number _____

Serial Number _____

Purchase Date _____

Because we continually improve the quality and performance of our products, we may modify this model before updating this manual. Visit www.dacor.com to view/download the latest version of this manual.

Important Information About Safety Instructions

These Important Safety Instructions and warnings cannot cover all possible situations. Use common sense and caution when installing/maintaining/using this appliance. Contact Dacor Customer Assurance about situations you cannot resolve.

Safety Symbols, Labels, and Alerts



DANGER

Immediate hazards that WILL cause severe personal injury/death.



WARNING

Hazards or unsafe practices that COULD cause severe personal injury/death.



CAUTION

Hazards or unsafe practices that COULD cause minor personal injury or property damage.

CALIFORNIA PROP 65 WARNING

The burning of gas generates by-products known by the State of California to cause cancer or reproductive harm. California law requires businesses to warn customers of potential exposure to such substances. To minimize exposure to these substances, operate this unit as instructed in this manual.



WARNING

Do not use this range as a space heater. Doing so may cause carbon monoxide poisoning and overheat the range.



AVERTISSEMENT

N'utilisez pas cette cuisinière comme chauffage d'appoint. Cela pourrait provoquer un empoisonnement au monoxyde de carbone et surchauffer la cuisinière.



WARNING

Follow the information in this manual exactly to avoid fire, explosion, property damage, personal injury, or death.

- Do not store or use gasoline or other flammable vapors and liquids near this appliance.
- IF YOU SMELL GAS:
 - Do not light any appliance.
 - Do not use any phone in your building.
 - Immediately call your gas supplier from a neighbor's home, and follow the supplier's directions.
 - If you cannot reach your gas supplier, call the fire department.
- Installation and service must be performed by a qualified installer, service agency, or the gas supplier.



AVERTISSEMENT

Suivez à la lettre les informations contenues dans ce manuel pour éviter les incendies, les explosions, les dommages matériels, les blessures ou la mort.

- Ne pas stocker ou utiliser de l'essence ou d'autres vapeurs et liquides inflammables près de cet appareil.
- SI VOUS ODEZ DU GAZ:
 - N'allumez aucun appareil.
 - N'utilisez aucun téléphone dans votre immeuble.
 - Appelez immédiatement votre fournisseur de gaz de la maison d'un voisin. Suivez les instructions du fournisseur de gaz.
 - Si vous ne pouvez pas joindre votre fournisseur de gaz, appelez les pompiers.
- L'installation et l'entretien doivent être effectués par un installateur qualifié, une agence de service ou le fournisseur de gaz.



WARNING

Do not cover the slots between the burner control knobs and the trim rings on the cooktop. Doing so blocks air flow and may cause carbon monoxide poisoning. Foil linings may trap heat, causing a fire hazard. Keep all the slots clean and clear.



AVERTISSEMENT

Ne couvrez pas les fentes entre les boutons de commande du brûleur et les bagues de garniture sur la table de cuisson. Cela empêche le flux d'air et peut provoquer un empoisonnement au monoxyde de carbone. Les doublures en aluminium peuvent emprisonner la chaleur et provoquer un incendie. Gardez toutes les fentes propres.

Important Safety Instructions

General Safety Precautions

To reduce the risk of fire, electric shock, serious injury or death when using your cooktop, follow basic safety precautions, including:

WARNING

- If you receive a damaged product, immediately contact your dealer or builder. Do not install or use a damaged appliance.
- Ensure the cooktop is installed and grounded by a qualified installer per the cooktop installation instructions. Have the installer show you the gas shut off valve and power cord so you know where and how to turn off the gas supply and unplug the cooktop.
- Do not install/repair/replace any part of the cooktop unless specifically recommended in the accompanying literature. A qualified service technician should perform all other service.
- Before doing any type of service, ensure the gas supply is turned off and the power cord is disconnected.
- Use the cooktop only for tasks consistent with a home appliance as outlined in this manual. The cooktop is not designed for commercial use.
- **DO NOT TOUCH THE SURFACES OF THE COOKTOP DURING OR IMMEDIATELY AFTER USE.** After use, make sure these surfaces have had sufficient time to cool before touching them.
- Ensure anyone who uses the cooktop can operate it properly.
- Never let anyone (including children) sit, stand, or climb anywhere on the cooktop. Doing so may cause damage, serious injury, or death.
- Do not leave children alone or unattended in the area around the cooktop. Do not allow children to play with the controls, pull on the handle or touch other parts of the cooktop.
- Do not store items of interest to children on top of or above the cooktop. Children could be burned or injured while climbing on the appliance.
- Do not attempt to use this appliance in the event of a power failure. If a power failure occurs while operating the cooktop, turn all control knobs to the OFF position.
- Do not tamper with the controls. Do not adjust or alter any part of the cooktop unless as specifically instructed in this manual.
- Put only properly selected cookware on the burners and grates. Decorative covers may cause a fire hazard or damage the cooktop if a burner is accidentally turned on with the cover in place.
- Do not leave the cooktop unattended while in use to avoid the possibility of fire.
- Do not heat sealed food containers such as baby food jars and cans. Pressure build up may cause the container to burst and cause injury.
- Clean the cooktop thoroughly before operating it for the first time.
- Keep flammable items, such as paper, cardboard, plastic and cloth away from the burners and other hot surfaces. Do not allow pot holders to touch hot surfaces or gas burners.
- Do not wear loose or hanging apparel while using the cooktop. Do not allow clothing to come into contact with the cooktop and surrounding areas during and immediately after use.
- Do not hang flammable or heat sensitive objects over the cooktop.
- If the cooktop is near a window, do not hang long curtains that could blow over the cooktop and create a fire hazard.
- Clean and maintain the cooktop regularly as instructed in this manual. Keep the entire cooktop, ventilation filters and cooktop hoods free of grease that could catch fire.
- Use cookware only for its intended purpose. Check the manufacturer's recommendations before use to determine if a utensil is suitable for use on a cooktop. Certain types of glass, ceramic and earthenware are not suitable for use on a cooktop. Personal injury or damage may result from the improper use of cookware.

WARNING

- Do not use towels or bulky cloth as pot holders.
- Select cookware carefully. Use cookware of the proper size, material and construction for the particular type of cooking being done. Cookware needs to be large enough to contain the desired quantity of food without boil-overs or spill-overs. Choose pans with easy to hold handles that will stay cool while cooking. Do not use cookware with loose handles. Avoid using pans that are too heavy to lift safely.
- Do not allow pots or pans to boil dry.
- Use extreme caution if adding water to food on a hot cooktop. The steam can cause serious burns or scalds.
- Use only dry pot holders when removing food and cookware from the cooktop. Wet pot holders can cause steam burns.
- Make sure that all the cooktop parts are dry before lighting a burner.
- Turn off all cooktop burners before removing control knobs.
- Never operate the cooktop without all knobs in place.
- Non-stick coatings, when heated, can be harmful to birds; move pet birds to a separate, well-ventilated room when using the cooktop.
- When deep fat frying:
 - be certain that the pan is large enough to contain the desired volume of food without overflow caused by the bubbling of the fat. Never leave a deep fat fryer unattended.
 - avoid frying moist or frost-covered foods. Foods with high water content may cause spattering or spilling of the hot fat.
 - heat fat slowly and stir together any combination of oils and fats prior to applying heat. Use a deep fat frying thermometer to avoid heating the fat to temperatures above the flash point.
- This cooktop has a 3-prong grounding plug to protect against possible electric-shock hazards. If only a 2-prong outlet is available, the owner shall have it replaced by a licensed electrician with a dedicated, grounded 3-prong electrical outlet.

Under no circumstances should you:

- cut or remove the power cords' third (ground) prong
- use an adapter plug
- use an extension cord
- use a power cord that is frayed or damaged
- plug the cooktop into an electrical outlet with a ground fault interrupter (GFI).

TO REDUCE RISK OF PERSONAL INJURY SHOULD A GREASE FIRE OCCUR:

- **SMOTHER FLAMES** with a close-fitting lid, cookie sheet or metal tray, then turn off the burner. **BE CAREFUL TO PREVENT BURNS.** If the flames do not go out immediately, **EVACUATE AND CALL THE FIRE DEPARTMENT.**
- **NEVER PICK UP A FLAMING PAN** - you may be burned.
- **DO NOT USE WATER**, including wet dish cloths or towels - a violent steam explosion may result.
- Use a fire extinguisher **ONLY** if:
 - you have a Class ABC extinguisher and you already know how to operate it.
 - the fire is small and contained in its area of origin.
 - the fire department is being called.
 - you can fight the fire with your back to an exit.

Important Safety Instructions

CAUTION

- Do not allow acids (citrus juices, tomato sauces, etc.) to remain on the cooktop's surfaces. The porcelain finish may stain.
- Never use the cooktop surface as a cutting board.
- Do not try to remove heavy spills with a sharp object such as a knife or metal spatula. Sharp objects may scratch the cooktop's surfaces.
- Do not expose the knobs or trim rings to direct flame, hot utensils or other sources of heat.

Getting to Know the Cooktop

Parts of the Cooktop

SimmerSear™ Burners: Dacor's exclusive burner system offers a wider range of heat settings than the standard burner, and allows you precise flame control from simmer to sear (low to high).

Sealed Burners: Gaskets around the underside of all burner bases prevent spills from leaking into the cooktop's internal parts.

Long-Life Grates: The porcelain-coated cast-iron grates are removable for easy cleaning/service of the area below.

Spill Tray: This one-piece tray catches any food that falls through the grates and protects the cooktop from boil-overs and drips.

Burner-Control Indicator Lights: Each knob has a blue indicator light that illuminates when you turn the burner on.

Other Features

Flameless Ignition: The cooktop generates a spark that ignites a burner when you turn the knob to the flame icon.

Perma-Flame™: The Perma-Flame instant re-ignition feature automatically and quickly relights a burner. Experience uninterrupted cooking from continuous heating.

Smart Flame™ Technology: All burners are equipped with Dacor's Smart Flame technology. It reduces the temperature under the fingers of the porcelain-coated cast iron grates. Smart-Flame extends the life of the grate and protects the finish.

HCT305G

A Standard burner:
1300 - 9000 BTU

B Standard burner:
1700 - 11000 BTU

C SimmerSear™ burner:
800-18000 BTU

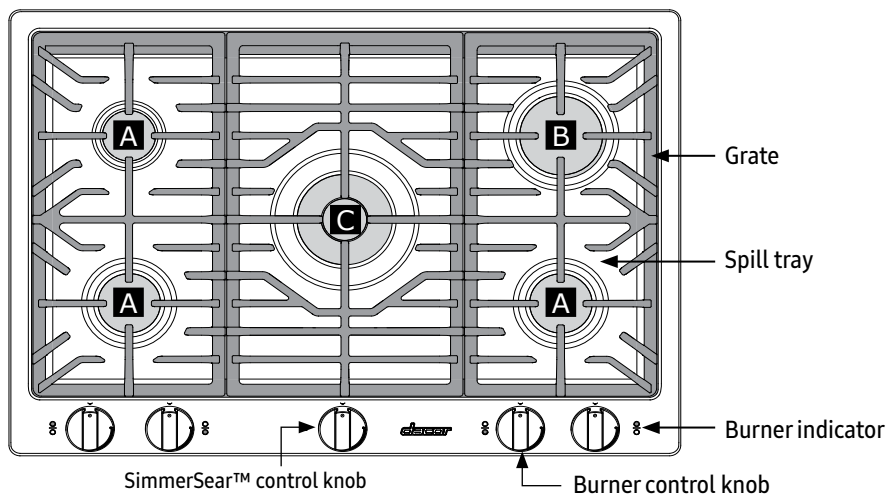

HCT365G

A Standard burner:
1300-9000 BTU

C SimmerSear™ burner:
800-18000 BTU

E Standard burner:
2500-12000 BTU

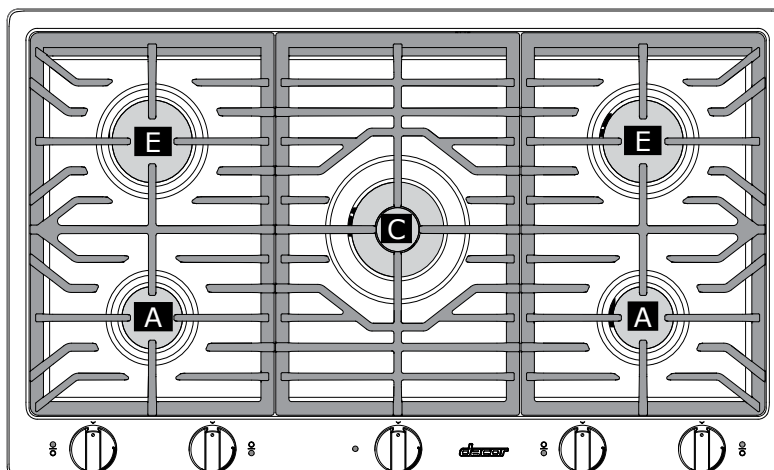

Setting Up the Cooktop

Installing the Burners and Grates

WARNING

Assemble the burners and grates only when the cooktop is cool.

Installing the SimmerSear™ Burner

Be sure to match the right-size components with each other.

1. Place the SimmerSear™ burner ring on the SimmerSear™ base (center of cooktop).
2. Align the burner-ring gaps with the pins on the burner base.
3. Seat the outer SimmerSear™ burner cap on the burner ring. Make sure it is centered and fully seated.
4. Place the inner SimmerSear™ burner cap in the center of the base. Seat the cap on the pins in the center of the base.

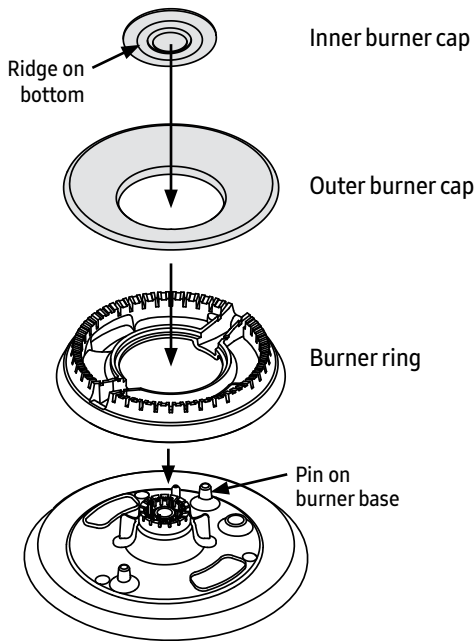

SimmerSear™ Burner Assembly
(center burner)

Installing a Standard Burner

Be sure to match the right-size components with each other.

1. Align the hole near the rim of the burner head with the ignitor on the base.
2. Place the burner ring on the burner head.
3. Put the burner ring on the head. Slightly turn the ring to make sure it seats properly.
4. Lay the cap on the burner ring. Make sure the ridge of the cap fits around rim of the ring.

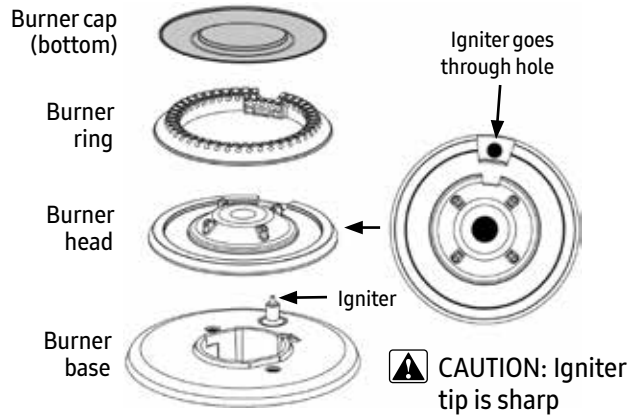

Standard Burner Assembly

Setting Up the Cooktop

Installing the Grates

IMPORTANT

- Assemble the grates as instructed. When installed correctly, the openings in the grates are centered over the burners.
 - When placing a grate, make sure its feet rest in their respective dimples formed into the cooktop.
1. Find the notch on the bottom-back of each grate, and orient the grate so the notch is toward the back of the cooktop.
 2. Place the grate with "bent fingers" (see the graphic) on the left on the left side of the cooktop, and vice versa the other side grate.
 3. Place the grate with no bent fingers and open center (see the graphic) in the center of the cooktop.

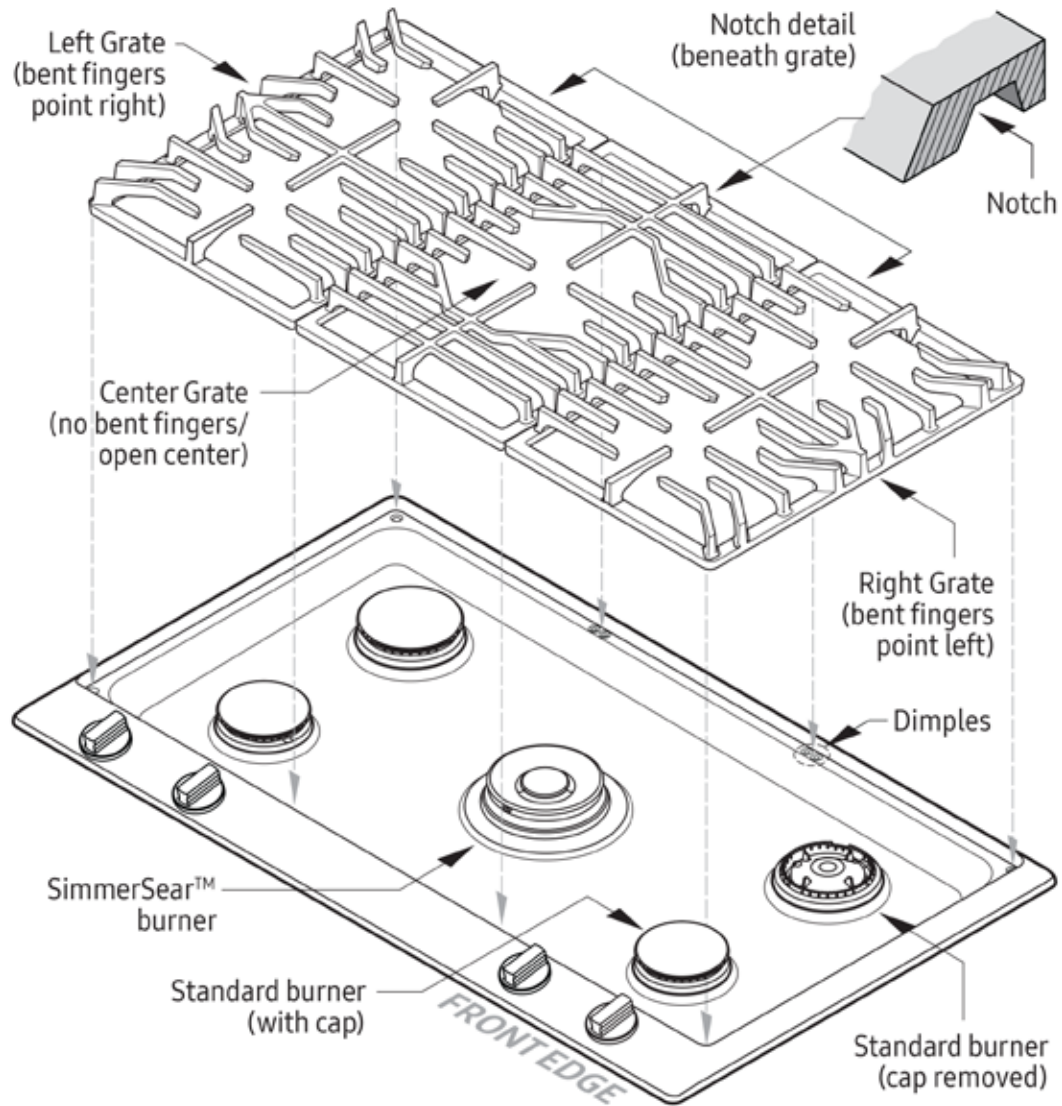

Operating the Cooktop

Selecting the Cookware

WARNING

- NEVER cover the slots between the burner-control knobs and trim rings. Doing so blocks air flow through the cooktop and may cause carbon monoxide poisoning. Keep all slots clean.
- To avoid burns and scalding, always turn pan handles away from burners and the edge of the countertop.
- Always lift cookware to reposition it. Sliding may damage the grate finish. Gently set and center cookware on the grates.
- Never use rough-bottomed cookware, which can permanently damage the grate finish.
- To avoid burns or a fire hazard, keep the flame level under the cookware.

For overall safety and best cooktop performance, select the correct cookware for the food being prepared. Improperly selected cookware will not cook food evenly or efficiently.

Use cookware that:

- Has flat, smooth bottoms.
- Is well balanced.
- Has tight fitting lids to keep heat, odors, and steam inside.

IMPORTANT: Wipe up spills as soon as possible. The porcelain surfaces of the grates, spill tray, and burner caps are acid-resistant but not acid-proof. Certain foods can permanently mar these surfaces if allowed to remain.

Lighting a Burner

WARNING

- To avoid risk of fire, explosion, or carbon monoxide poisoning, always use the cooktop with the burners properly assembled (see Pg. 4). The burner rings spread the flame evenly around the burner cap. The rings must be fully seated for correct burner function.
- For safety's sake, always light the burner before putting the cookware on the grate, and turn it off before removing cookware. Always check the position of the control knobs to verify the cooktop is off when you finish cooking.
- Do not turn the knob past the HIGH flame mark until lit. Doing so may result in a burst of flame that could cause burns or damage to the surrounding area.
- Do not touch any part of the burner while the igniter is sparking. An electrical shock could result.
- Never light the burners with a match or other open flame.
- If the gas does not ignite after 4 seconds or if the flame goes out and gas escapes, turn off the burner. Open a window, and wait at least 5 minutes for the gas to dissipate before retrying.

1. Press a burner-control knob (see the burner indicator icon on the cooktop), and turn it slowly counterclockwise.

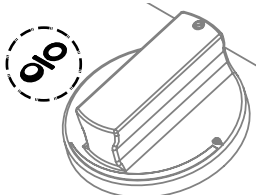

As you turn the knob, the igniter sparks until the flame ignites, then stops sparking.

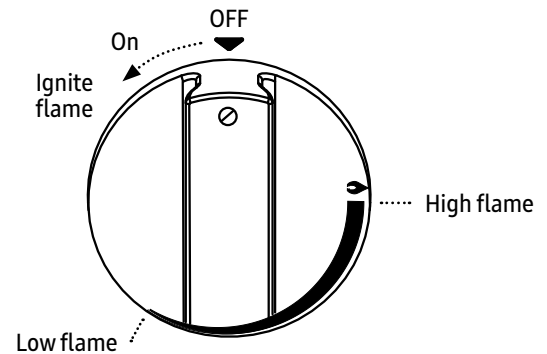

2. Turn the knob to adjust the flame.

SimmerSear™ Burners

This is a type of "dual burner" that gives a much wider temperature range than the standard burners.

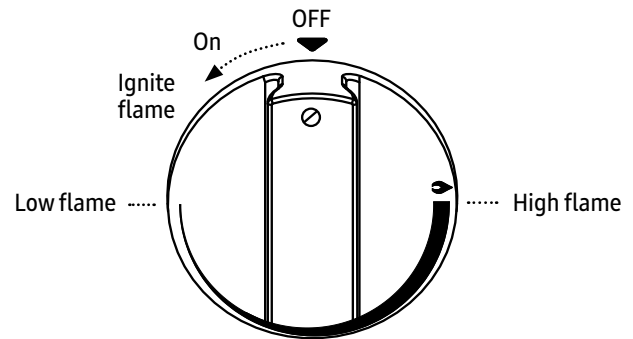

IMPORTANT

- When the cooktop is cool, the igniter may continue to spark if the burner knob is set to the LOW position. The burner will stop sparking when warm.
- The tendency to spark when cold can be reduced by using the burner at a higher flame for about 60 seconds. After 60 seconds, lower the flame to cook. The burner will also warm up faster if cookware is placed its grate.
- The igniter will also spark automatically if the flame is distorted by a draft or by the household ventilation system. Eliminate any drafts or reduce the ventilation blower speed to reduce this type of problem.
- To keep the burners operating properly, keep the burner igniters, burner rings, and burner caps clean and dry. See Care and Cleaning starting on page 10. Dirty or wet igniters will cause constant sparking, even if there is a flame.
- The flame should burn evenly around the rim of the burner, except underneath "grate support fingers", where the flame height is reduced by Dacor's Smart-Flame feature.
- An optimal flame burns steady and blue. Foreign material in the gas line, especially in new construction, may cause an orange flame during initial use. The orange color will disappear with further use. Small yellow tips on the ends of the flames are normal when using LP gas.

Operating the Cooktop

Cooking Tips

For best cooking results and to save energy:

- Boil at the lowest flame height possible. Food cooks just as quickly at a gentle boil as at a vigorous boil, which wastes energy and cooks out moisture, flavor, and nutrients faster.
- Use low/med flame if using poor-heat-conducting cookware (e.g., glass, ceramic, cast iron).
- Adjust the flame so it covers about $\frac{1}{3}$ of the bottom of the cookware to ensure even heating and reduce scorching.
- Use minimal liquid or fat to reduce cook times.
- Using a timer and not removing the lid to check food reduces cook time and saves energy.
- Dacor SimmerSear™ allows precise flame control. The larger the burner, the broader the control. (See Pg. 4 for burner heat ranges.)

Accessories

Wok Ring (Part# AWR4): This is a safe, convenient way to stir-fry. Place the ring on top of the grate, aligning the wok ring feet with the grate fingers. The ring holds most standard-sized woks.

Griddle/Grill (Part# AGDCT12): This easy-to-clean device sits atop your cooktop. The griddle side is designed for cooking pancakes, eggs, bacon, and other pan-fried foods. The reverse (grill) side is designed for any such food as you would cook on an outdoor grill.

See details on how to use/purchase these accessories at www.dacor.com.

Care and Cleaning

Cleaning the Cooktop

To keep the cooktop looking and operating its best, clean it after every use. Also, quickly wipe up spills that occur while cooking. Be careful not to touch any hot areas.

If you allow spills to sit on hot burner parts, they will burn and be very difficult to clean. Certain types of food, such as tomatoes, citrus juices, vinegar, alcohol, and milk can damage the finishes if you allow them to stand for any length of time.

IMPORTANT

- The cooktop is exposed to extremely high temperatures. The grates are under high stress when hot cookware is on them.
- Acidic foods (tomato sauce, citrus, et al.) are occasionally spilled on cooktop components. This discolors the porcelain-enamel parts over time. To slow—but not eliminate—the aging process, wipe up such spills as soon as safely possible.

Disassembly

- See disassembly illustrations on Pgs. 4 – 5.
- Perform this procedure only if all surfaces are sufficiently cool.

1. Unplug the cooktop.
2. When the cooktop is cool, remove the grates from the top of the cooktop.
3. Disassemble the burners:

Standard Burner Disassembly

Lift the cap covers and burner heads off the burner bases.

SimmerSear™ Burner Disassembly

Lift the cap cover and burner cap off the burner head(s).

SimmerSear™ burner head(s) are not removable.

WARNING

- Clean only the cooktop parts listed in this manual and only in the manner specified.
- To avoid dangerous fumes or damage to cooktop surfaces/parts, use only the types of cleaning solutions specified in this manual.
- To avoid personal injury, turn off the burners, and ensure all parts are cool before cleaning. Leave all burners off while cleaning.
- Do not steam clean the cooktop. Steam could penetrate the electrical parts and cause a short circuit. After cleaning the burners, reassemble all burners before operating the cooktop.
- After cleaning the burners, always dry and reassemble the cooktop parts completely before use. (See Pg. 11.)

CAUTION

- Do not remove heavy spills with a sharp object (e.g., knife, metal spatula). Sharp objects may scratch your cooktop's surfaces.
- Do not use abrasive/corrosive cleaners or scrubbing tools anywhere on the cooktop unless instructed to do so. Use only a sponge, soft cloth, fibrous/plastic brush, or nylon cleaning pad on the cooktop.
- Take care when cleaning around the control valve stems. Moisture inside the chassis can damage the cooktop.
- Do not soak the control knobs in water or put them in the dishwasher.

Cleaning the Grates and Spill Trays

WARNING

The cooktop grates, burner components, and wok ring are not dishwasher-safe.

IMPORTANT

- DO NOT use the cleaners listed below on the burners and igniters. (See Pg. 11 for burner and igniter cleaning instructions.)
- If your cooktop spill tray is stainless-steel, see **Cleaning Stainless Steel Surfaces** for instructions.

The grates, the spill tray (on some models) and optional wok ring have a porcelain coating.

- For everyday cleaning, use a soft cloth or non-abrasive pad with warm soapy water to clean all of the porcelain parts.
- Tough stains may be removed by applying full-strength sprays such as Simple Green™, Ajax™ All-Purpose Cleaner, or Formula 409™. To limit wear, use the mildest cleaner needed for the task.
- For extremely stubborn stains, you may use a mildly abrasive cleaner or applicator, such as Soft Scrub™, Bon Ami™, S.O.S.® pads, or other soap-filled steel-wool pads.

Use these cleaners carefully and only occasionally. Aggressive or extensive use of these types of abrasives will mar the finish. Damage to the finish due to use of abrasives is not warranted.

Cleaning the Burner-Control Knobs

1. Turn off all burner-control knobs.
2. Unplug the cooktop.
3. Grasp a knob, and pull it straight off the valve stem.

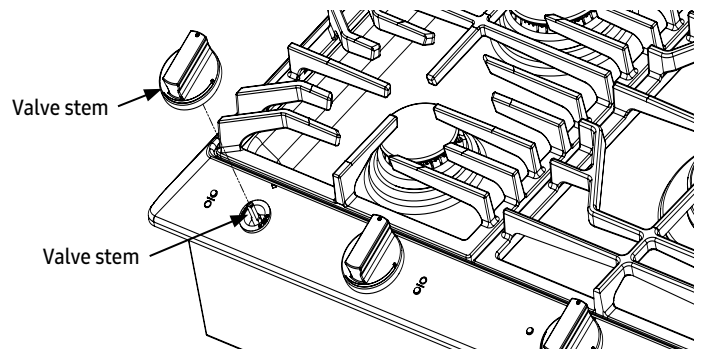

4. Wash the knobs with liquid dish soap.
5. Align the “D-shaped” key on the bottom of the knob with the same-shape valve stem, and carefully push the knob onto the stem until it stops.
6. With dry hands, plug in the cooktop.

Care and Cleaning

Cleaning the Burners and Igniters

 **WARNING**

Use care while cleaning the igniters. The porcelain is fragile and can crack or break.

IMPORTANT: The igniters will not work properly if they or the other burner parts are not clean. Dirty/wet igniters may not spark at all.

1. Disassemble the burners, and check for any dirt/grime on the individual parts, including the igniters.
2. Clean completely around the igniter, including over and under the edge of the metal top and porcelain base. (A toothbrush with firm bristles is ideal for this task.)
Porcelain is fragile and can crack or break. Do not use water to clean the igniters. If needed, use a small amount of rubbing alcohol to help dissolve grime. The alcohol will evaporate.
3. On the burner bases, remove anything stuck in the holes with a straightened paper clip, wire, or needle.
Do not to scratch or damage the ring and head, or distort the burner holes. The SimmerSear™ burner base is not removable.
4. With a plastic-bristled brush or firm-bristled toothbrush, clean all burner parts with window cleaner or rubbing alcohol. When done, rinse the parts well with clean water, and dry all the parts thoroughly.
5. Reassemble the cooktop according to the burner and grate assembly instructions on Pgs. 4 – 5.
6. Test the functions of all burners.
If the flame is uneven, verify proper assembly, then check for residual dirt/grime on all burner parts, verify all parts are thoroughly dry, and retest.
If problems remain, call a Dacor Authorized Service Agent.

Cleaning Stainless Steel Surfaces

 **WARNING**

Always wipe stainless steel surfaces with the grain. To prevent scratches, do not use abrasive cleaners or scrubbers on stainless steel surfaces.

- Clean only stainless steel surfaces with the Dacor Stainless Steel Cleaner included with your cooktop.
- Additional stainless steel cleaner is available at www.everythingdacor.com, part# A302.
- You can also clean stainless steel surfaces with a mild solution of liquid soap and warm water. Rinse and dry with a soft, lint-free cloth.

Troubleshooting

Problem	May Be Caused By	What to Do (Solution)
Nothing works.	No power to cooktop.	Verify the cooktop is plugged in.
	No power to electrical outlet.	Turn on power at circuit breaker or fuse box; check for tripped breaker or blown fuse.
	Power outage.	Contact power company.
Igniters not sparking.	Power not supplied to unit.	See Nothing Works (above).
	Wet/dirty igniter.	Perform Cleaning the Burners and Igniters (Pg. 9).
No flame.	Igniter not working (no clicking sound).	See Igniters do not spark , above.
	Wet/dirty igniter.	Perform Cleaning the Burners and Igniters (Pg. 9).
	Gas turned off.	Make sure gas-supply valve is open.
	Gas supply interrupted.	Contact gas company.
Burner goes out at low setting.	Low gas pressure.	Contact gas company to have pressure tested.
Flame distorted, yellow, or too large.	Burner parts dirty/clogged.	Perform the procedure Cleaning the Burners and Igniters (Pg. 9).
	Burner parts improperly assembled.	Inspect burner assembly (see Installing the Burners and Grates , Pg 4).
	Cooktop set up for other type of gas (Natural or LP) or different altitude.	Have qualified technician check cooktop suitability for gas type and altitude.
	Gas regulator faulty or not installed.	Have a qualified service technician check the gas regulator.
Igniter sparks (clicks) after flame ignites.	Burner is cold.	Burners may spark up to 60 seconds when cold and set to low; see Lighting a Burner , Pg. 6, for details on minimizing this issue.
	Flame distorted by draft.	Minimize drafts around the cooktop. Close nearby windows.
	Wet/dirty igniter or burner parts.	Perform Cleaning the Burners and Igniters (Pg. 9).
	Burner parts not properly positioned.	See Installing the Burners and Grates , Pg 4).
	Power supply polarity is reversed.	Have a licensed electrician check the electrical outlet.

Warranty and Service

Getting Help

Before you request service:

1. Review **Troubleshooting** (this page).
2. Know the cooktop's warranty terms and conditions.
3. If none of these tips/suggestions resolves your issue, or if you have warranty/non-warranty, or operational issues, call Dacor Customer Assurance:

833-35-ELITE (833-353-5483) USA, Canada

5:00 a.m. – 5:00 p.m. Pacific Time

Website: www.dacor.com/customer-care/contact-us

Warranty

What Is Covered

CERTIFICATE OF WARRANTIES

DACOR GAS COOKTOPS

WITHIN THE 50 STATES OF THE U.S.A., DISTRICT OF COLUMBIA, AND CANADA*:

FULL 1-YEAR WARRANTY

The warranty applies only to the Dacor appliance sold to the first use purchaser, starting from the date of original retail purchase or closing date for new construction, whichever period is longer. Warranty is valid on products purchased brand new from a Dacor Authorized Dealer, or other seller authorized by Dacor.

If your Dacor product fails to function within one year of the original date of purchase, due to a defect in material or workmanship, Dacor will remedy it without charge to you.

All cosmetic damage (such as scratches on stainless steel, paint/porcelain blemishes, etc.) to the product or included accessories

Warranty and Service

must be reported to Dacor within 60 days of the original purchase date to qualify for warranty coverage.

Consumable parts such as filters and light bulbs are not covered and are the responsibility of the purchaser.

LIMITATIONS OF COVERAGE

Service will be provided by a Dacor designated service company during regular business hours. Please note service providers are independent entities and are not agents of Dacor.

Dealer display and model home display products with a production date greater than 5 years, products sold "As Is," and products installed for non-residential use, which include but are not limited to religious organizations, fire stations, bed and breakfast and spas carry a one year parts warranty only. All delivery, installation, labor costs and other service fees are the responsibility of the purchaser.

Warranty will be null and void on product that has altered, defaced, or missing serial numbers and tags.

The owner must provide proof of purchase or closing statement for new construction upon request. All Dacor products must be accessible for service.

*Warranty is null and void if non-ETL or non-CUL approved product is transported from the U.S.A.

OUTSIDE THE 50 STATES OF THE U.S.A., DISTRICT OF COLUMBIA, AND CANADA:

LIMITED FIRST-YEAR WARRANTY

If your Dacor product fails to function within 1 year of the original purchase date due to material or manufacturing defect, Dacor will furnish a new part, F.O.B. factory to replace the defective part.

All delivery, installation, labor costs and other service fees are the responsibility of the purchaser.

What Is Not Covered

- Slight color variations may be noticed because of differences in painted parts, kitchen lighting, product placement and other factors; this warranty does not apply to color variation.
- Service calls to educate the customer on proper use and care of the product.
- Service fees for travel to islands and remote areas, which include but are not limited to, ferries, toll roads or other travel expenses.

- Consequential/incidental damage, including but not limited to food or medicine loss, time away from work, or restaurant meals.
- Failure of the product when used for commercial, business, rental or any application other than for residential consumer use.
- Failure of the product caused by improper product installation.
- Replacement of house fuses, fuse boxes or resetting of circuit breakers.
- Damage to the product caused by accident, fire, flood, power interruption, power surges or other acts of God.
- Liability or responsibility for damage to surrounding property including cabinetry, floors, ceilings and other structures or objects around the product.
- Breakage, discoloration, or damage to glass, metal surfaces, plastic components, trim, paint or other cosmetic finish caused by improper usage, care, abuse, or neglect.

Out of Warranty

Should you experience a service issue beyond the standard warranty period, please contact us. Dacor reviews each issue and customer concern to provide the best possible solution based on the circumstances.

THE REMEDIES PROVIDED IN THE ABOVE EXPRESS WARRANTIES ARE THE SOLE AND EXCLUSIVE REMEDIES. THEREFORE, NO OTHER EXPRESS WARRANTIES ARE MADE, AND OUTSIDE THE FIFTY STATES OF THE UNITED STATES, THE DISTRICT OF COLUMBIA AND CANADA, ALL IMPLIED WARRANTIES, INCLUDING BUT NOT LIMITED TO, ANY IMPLIED WARRANTY OF MERCHANTABILITY OR FITNESS FOR A PARTICULAR USE OR PURPOSE, ARE LIMITED IN DURATION TO ONE YEAR FROM THE DATE OF ORIGINAL PURCHASE. IN NO EVENT SHALL DACOR BE LIABLE FOR INCIDENTAL EXPENSE OR CONSEQUENTIAL DAMAGES. IN THE EVENT DACOR PREVAILS IN ANY LAWSUIT, DACOR SHALL BE ENTITLED TO REIMBURSEMENT OF ALL COSTS AND EXPENSES, INCLUDING ATTORNEY'S FEES, FROM THE DACOR CUSTOMER. NO WARRANTIES, EXPRESS OR IMPLIED, ARE MADE TO ANY BUYER FOR RESALE.

Some states do not allow limitations on how long an implied warranty lasts, or do not allow the exclusion or limitation of inconsequential damages, therefore the above limitations or exclusions may not apply to you. This warranty gives you specific legal rights, and you may also have other rights that vary from state to state.

Notes

fold here



NO POSTAGE
NECESSARY
IF MAILED
IN THE
UNITED STATES

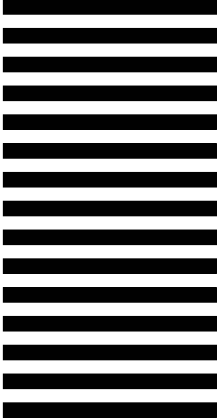

BUSINESS REPLY MAIL
FIRST-CLASS MAIL PERMIT NO 1600 CITY OF INDUSTRY CA

POSTAGE WILL BE PAID BY ADDRESSEE

**DACOR
ATTN WARRANTY PROCESSING DEPT
PO BOX 90070
CITY OF INDUSTRY CA 91715-9907**





Please visit www.dacor.com to activate your warranty online.

WARRANTY INFORMATION

**IMPORTANT:**

Your warranty will not be activated until you activate it online or return this form to Dacor. If you have purchased more than one Dacor product, please return all forms in one envelope, or activate the warranty online for each product.

Please be assured that Dacor will never sell your name or any information on this form for mailing-list purposes, as we do not consider it a proper way of expressing our gratitude for your having chosen Dacor products for your kitchen!

Owner Last Name (please print) _____ First _____ Middle Init. _____

Street _____

City _____ State _____ Zip _____

Purchase Date _____ Email _____ Phone _____

Dealer _____

City _____ State _____ Zip _____

Your willingness to take a few seconds to complete the section below will be sincerely appreciated. Thank you.

1. How were you first exposed to Dacor products? (Please check one.)

- A. T.V. Cooking Show
- B. Magazine
- C. Appliance Dealer Showroom
- D. Kitchen Dealer Showroom
- E. Home Show
- F. Builder
- G. Architect/Designer
- H. Another Dacor Owner
- I. Model Home
- J. Other _____

2. Where did you buy your Dacor appliances?

- A. Appliance Dealer
- B. Kitchen Dealer
- C. Builder Supplier
- D. Builder
- E. Other _____

3. For what purpose was the product purchased?

- A. Replacement only
- B. Part of a Remodel
- C. New Home
- D. Other _____

4. What is your household income?

- A. Under \$75,000
- B. \$75,000 – \$100,000
- C. \$100,000 – \$150,000
- D. \$150,000 – \$200,000
- E. \$200,000 – \$250,000
- F. Over \$250,000

5. What other brands of appliances do you have in your kitchen?

- A. Cooktop _____
- B. Oven _____
- C. Dishwasher _____
- D. Refrigerator _____

6. Would you buy or recommend another Dacor product?

- Yes
- No

Comments _____

Thank you very much for your assistance. The information you have provided will be extremely valuable in helping us plan for the future and in giving you the support you deserve.



cut here

cut here