

# USER MANUAL BATTERY CHARGER



## CHARGEVERTER-GC

SCAN FOR UPDATED  
DOCUMENTS





## TABLE OF CONTENTS

1.	SPECIFICATIONS .....	2
2.	ABBREVIATIONS .....	3
3.	SAFETY INSTRUCTIONS .....	4
4.	BRIEF INTRODUCTION.....	5
4.1	CHARGEVERTER-GC OVERVIEW.....	5
4.2	CHARGEVERTER-GC AC CONNECTIONS .....	6
5.	INSTALLATION .....	7
5.1	UNPACKING AND INSPECTION .....	7
5.2	MOUNTING THE CHARGER .....	8
5.3	AC AND DC CONNECTIONS .....	9
6.	OPERATION.....	9
6.1	POWER ON/OFF .....	9
6.2	OPERATION AND DISPLAY PANEL .....	9
6.2.1	LCD INTERFACE.....	10
6.2.2	LCD PARAMETER SETTINGS .....	12
6.3	CHARGER COMMUNICATIONS .....	15
6.4	DRY CONTACT DESCRIPTION .....	16
6.5	WORKING WITH A GENERATOR .....	17

## 1. SPECIFICATIONS

<b>CHARGER OUTPUT SPECIFICATIONS</b>	
Battery Voltage	48VDC nominal
Charge Current (adjustable)	0-100A @240VAC, 0-45A @120VAC, 0-50A @208VAC
Charge Voltage (adjustable)	43-57VDC (default 54VDC)
Max. Output	5120W @240VAC, 3050W @120VAC
Max. Efficiency	94% @240VAC, 92% @120VAC
<b>AC INPUT SPECIFICATIONS</b>	
AC Input Voltage Range	90-264VAC
AC Frequency	50-60Hz
Max. Input Current	26A @240VAC, 28A @120VAC
Idle Consumption	~10W
<b>ENVIRONMENTAL SPECIFICATIONS</b>	
Operating Temperature Range	14°F – 131°F (-10°C – 55°C)
Storage Temperature Range	5°F – 140°F (-15°C – 60°C)
Humidity	5% to 95% relative humidity (non-condensing)
Ingress Protection	IP21
Operating Altitude	0~4921 ft. (0~1500m)
<b>DRY CONTACT SPECIFICATIONS</b>	
Interface Connector	NO, NC, and C (RJ11 Jack)
<b>GENERAL SPECIFICATIONS</b>	
Communication Port	RS485 (RJ45 Jack)
Dimensions H x W x D	5" x 13.2" x 4.9" (127mm x 335mm x 124mm)
Net Weight	13 lbs. (5.9 kg)
Warranty	3 years (only when used indoors)



**CAUTION:** Use extreme caution when installing the Chargeverter-GC in an Energy Storage System (ESS) that has an inverter. Do not establish closed-loop communication between the battery and the Chargeverter-GC if the battery is already in closed-loop communications with the inverter!

## 2. ABBREVIATIONS

A – Amp(s)	kW – Kilowatt
AC – Alternating Current	kWh – Kilowatt-hour
Ah – Amp hour(s)	L1 – Line 1
AHJ – Authority Having Jurisdiction	L2 – Line 2
ANSI – American National Standards Institute	LCD – Liquid Crystal Display
AWG – American Wire Gauge	LFP – Lithium Iron Phosphate or LiFePO <sub>4</sub>
BAT – Battery	mm – Millimeter(s)
BMS – Battery Management System	MPPT – Maximum Power Point Tracker
COM – Communication	ms – Millisecond(s)
CT – Current Transformer	mV – Millivolt(s)
DC – Direct Current	NEC – National Electrical Code
DIP – Dual In-line Package	NEMA – National Electrical Manufacturers Association
DOD – Depth of Discharge	NFPA – National Fire Prevention Association
EG – Equipment Ground	Nm – Newton Meters
EGS – Equipment Grounding System	NOCT – Normal Operating Cell Temperature
EPS – Emergency Power System	PC – Personal Computer
ESS – Energy Storage System	PCB – Printed Circuit Board
E-Stop NO – Emergency Stop Normally Open	PE – Protective Earth (G or Ground)
FCC – Federal Communication Commission	PPE – Personal Protective Equipment
GE – Grounding Electrode	PV – Photovoltaic
GEC – Grounding Electrode Conductor	RSD – Rapid Shut Down
GEN – Generator	SCC – Standards Council of Canada
GES – Grounding Electrode System	SOC – State of Charge
GFCI – Ground Fault Circuit Interrupter	STC – Standard Testing Conditions
GFDI – Ground Fault Detector/Interrupter	UL – Underwriters Laboratories
IEEE – Institute of Electrical and Electronic Engineers	UPS – Uninterrupted Power Supply
Imp – Maximum Power Point Current	V – Volt(s)
In. lbs. – Inch Pounds	VMP – Voltage Maximum Power
IP – Ingress Protection	VOC – Open-Circuit Voltage
Isc – Short-Circuit Current	

## 3. SAFETY INSTRUCTIONS



**WARNING:** The following section contains important safety and operating instructions. Read the manual fully before putting the Chargeverter-GC into operation!



**CAUTION:** This charger is designed to charge lithium batteries. Other battery chemistries are supported, however, the battery manufacturer should be contacted prior to use to verify charging specifications. Otherwise, battery damage and/or bodily harm may occur.

1. Before using the unit, read all instructions and cautionary markings on the unit, the batteries, and all appropriate sections of this manual.
2. Do not disassemble the unit. When service or repair is required, take it to a qualified service center. Incorrect re-assembly may result in a risk of electric shock or fire.
3. To reduce risk the of electric shock, disconnect the AC source and DC load before attempting maintenance or troubleshooting.
4. **CAUTION** - *Use extreme care when attaching this device to a battery.*
5. **NEVER** charge a frozen battery.
6. Use caution when working with metal tools on or around batteries. A potential risk exists for a dropped tool to spark or short circuit batteries or other electrical parts causing a fire.
7. Please strictly follow the installation procedure when connecting or disconnecting DC terminals. Please refer to the installation section of this manual for details.
8. Breakers are required as overcurrent protection for the power supply.
9. **GROUNDING INSTRUCTIONS** -This charger should be connected to a permanent grounded wiring system. Be sure to comply with local requirements and regulations when using this charger.
10. **NEVER** short DC inputs.



**WARNING:** Only qualified personnel can service this device. Please contact the technical department of the distributor where this product was purchased for assistance with any issues.

### **DISCLAIMER**

EG4 reserves the right to make changes to the material herein at any time without notice. The most updated version of the manual can be found on the EG4 website at <https://eg4electronics.com/>

## 4. BRIEF INTRODUCTION

This manual describes the installation and operation of the EG4 Chargeverter-GC. Please read this manual carefully before installation and operation.

### 4.1 CHARGEVERTER-GC OVERVIEW

The EG4 Chargeverter-GC is a robust AC-to-DC converter designed specifically for 48 VDC Lithium battery charging in on-grid and off-grid Energy Storage Systems. The charger can operate on 120, 208, or 240VAC and is capable of up to 100 Amps of DC charging current. The inputs, outputs, and interface controls are identified in the figure and table below.

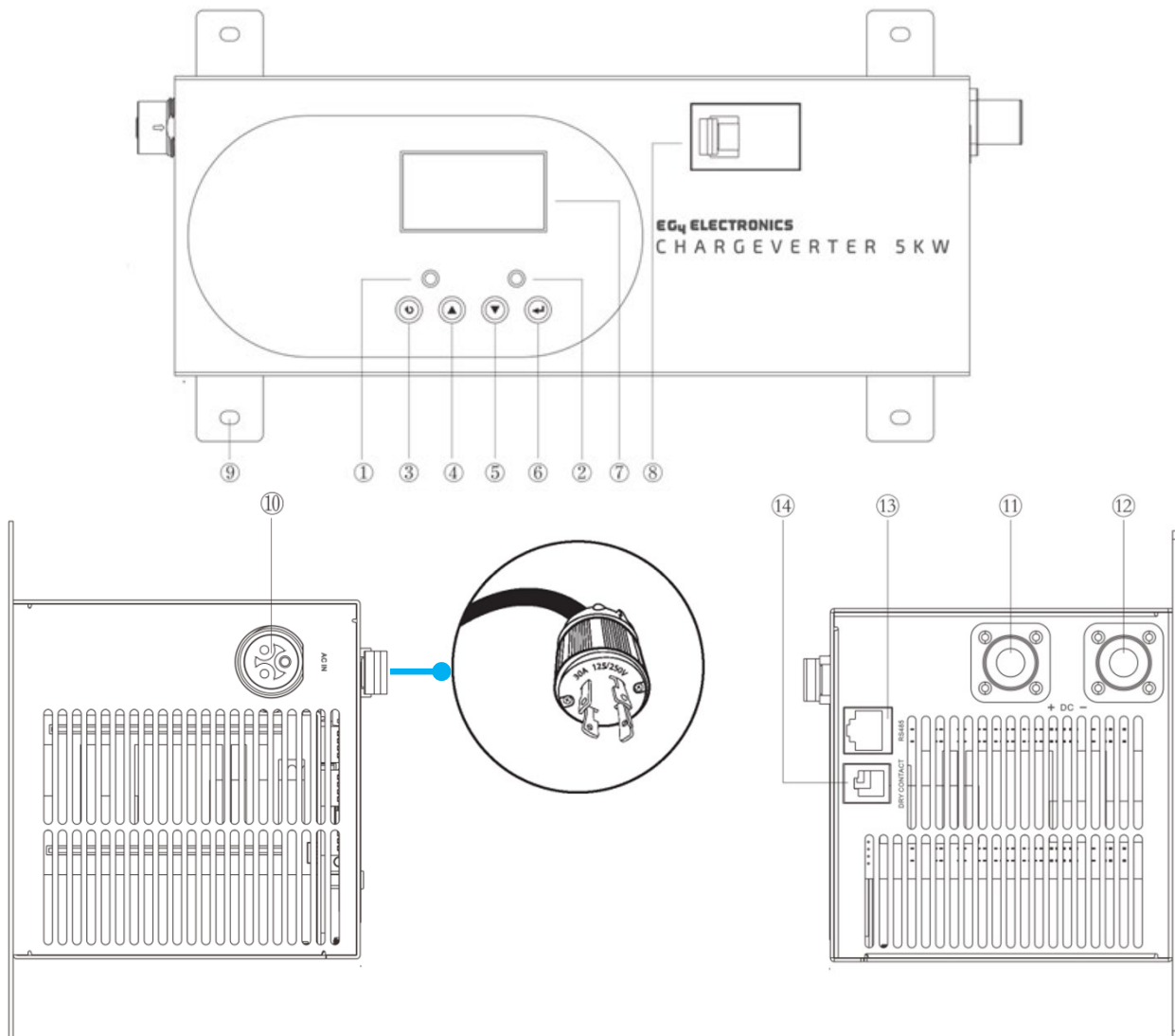

No.	Description	No.	Description
1	Power Indicator	8	Battery Breaker
2	Charging Indicator	9	Mounting Bracket
3	Function Button – ESC (Escape)	10	AC Input Connector
4	Function Button – UP	11	Positive Battery Quick Connector
5	Function Button – DOWN	12	Negative Battery Quick Connector
6	Function Button – ENTER	13	RS485 Communication Port (RJ45)
7	LCD Interface	14	Dry Contacts Communications Port (RJ11)

## 4.2 CHARGEVERTER-GC AC CONNECTIONS

The Chargeverter-GC comes pre-wired for a 240V/30A circuit with a NEMA L14-30P 4-prong male twist lock plug as shown in the figures above and below.

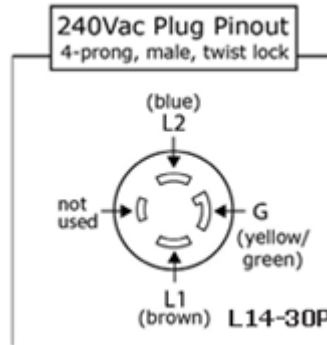

The pinouts for other common NEMA 120V/30A and 208V/30A circuits are provided below for reference.

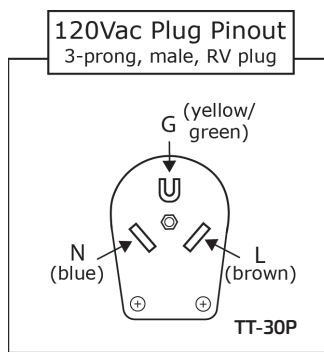
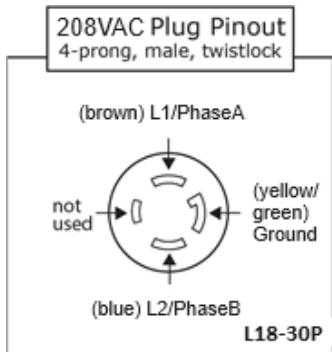
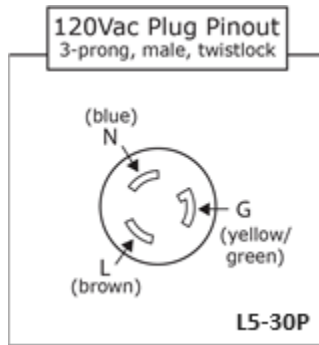
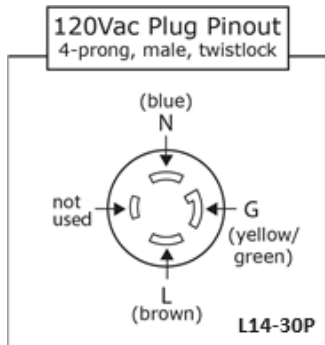

**Warning!!** Plug pinouts are provided for reference only. Please seek guidance from a qualified professional before making any modifications.

Charger AC Wire Color	120V	208V	240V
Brown	L1 (Hot)	L1 (Phase A)	L1
Blue	Neutral	L2 (Phase B)	L2
Yellow/Green	Ground	Ground	Ground



The charger's maximum output current is dependent on the input AC voltage as shown in the following table:

Charger Input AC	Maximum DC Output Current
120VAC/28A	45 Amps
208VAC/26A	50 Amps
240VAC/26A	100 Amps



**NOTE:** For single-phase 230VAC installations, please use the following information to properly wire the appropriate plug to the Chargeverter-GC.

Charger AC Wire Color	Description
Brown	230VAC
Blue	Neutral
Yellow/Green	Ground

## 5. INSTALLATION

### 5.1 UNPACKING AND INSPECTION

Before installation, please inspect the unit. Be sure that nothing inside the package is damaged. The following items will arrive in the shipment.

- Chargeverter-GC
- User Manual
- (5) Mounting Screws (M4-0.7 x 7), to mount the charger (4 for mounting & 1 spare)
- (2) Mounting Brackets
- (5) Mounting Screws (M3), to connect the mounting brackets to the charger (4 for mounting & 1 spare)
- RS485 Communication cable (RJ45 Plug to RJ45 Plug)
- RS485 to USB upgrade cable (RJ45 Plug to USB-A)
- Dry contact cable (RJ11 Plug to three bare and tinned wire pairs labeled Normally Open (NO), Normally Closed (NC), and Common (C) for connection to an external device (e.g. generator).

## 5.2 MOUNTING THE CHARGER

Consider the following points before selecting where to install the charger:

- Do not mount the charger on flammable construction materials.
- Mount the charger to a vertical, structurally sound wall.
- Suitable for mounting on concrete or other non-combustible surfaces only.
- Install this charger in a location that allows the LCD interface to be easily viewed.
- The ambient temperature should be between 32°F – 131°F (0°C – 55°C) to ensure optimal operation.
- Verify there is sufficient room for heat dissipation and space for wires.

Install the four mounting brackets to the back of the charger with the four M3-0.5 screws provided with the unit (there is one spare). Level and mount the charger to an appropriate wall by securing with the four M4-0.7 x 7 screws provided with the unit. Other fastening methods are also acceptable if the charger's weight of 13 lbs. (5.9 kg) is sufficiently supported. (e.g., concrete anchors, toggle bolt anchors, lag bolts, wood screws, etc.)

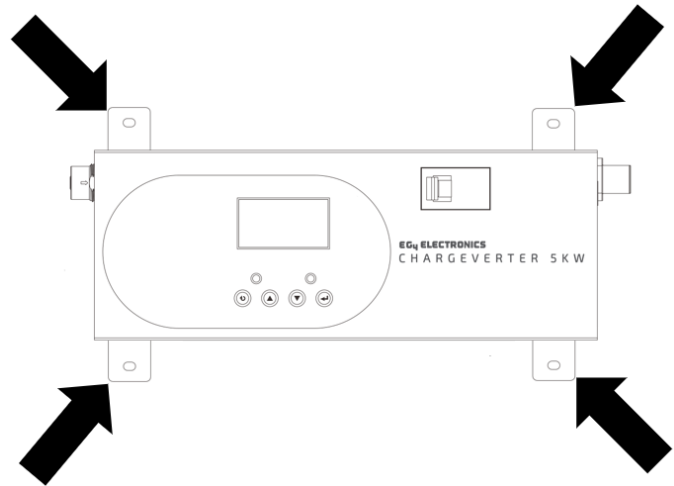

**HOT! The Chargeverter-GC can produce temperatures of more than 131°F (55°C). It is recommended to mount this unit on appropriate backing, such as cement board, with sufficient clearance around the unit to allow proper airflow. Do not block the air vents!**



**WARNING:** Ensure battery breakers and/or battery on/off switches are in the OFF position and the charger is not plugged in while installing battery charging cables.

## 5.3 AC AND DC CONNECTIONS

- Connect battery cables to the battery terminals or bus bars using appropriate size bolts for the battery.
- Ensure charger cable ring terminals are attached to the battery terminals or busbar with the proper polarity and tightened to the proper torque specifications for the battery.
- For 240V usage, plug the charger into a 240V 30A twist lock receptacle with a dedicated 30A breaker.
- For 208V usage, plug the charger into a 208V 30A receptacle with a dedicated 30A breaker.
- For 120V usage, plug the charger into a 120V 30A receptacle with a dedicated 30A breaker.



**NOTE:** Please see plug pinouts in Section 4.2 for common plug types.

## 6. OPERATION

### 6.1 POWER ON/OFF

1. Ensure that the battery cables are securely connected.
2. Plug the charger into an outlet of the proper voltage and amperage.
3. Turn on battery breakers and/or battery on/off switches.
4. Turn the charger's breaker on the front of the unit to ON.

The unit will begin charging and working normally if properly connected.

### 6.2 OPERATION AND DISPLAY PANEL

The operation and display panel shown on the right is located on the front panel of the charger. It includes two green LED indicators, four function buttons and an LCD interface indicating the operational and charging status of the unit.

The following tables show the LED indicator modes and the function-button descriptions, respectively.

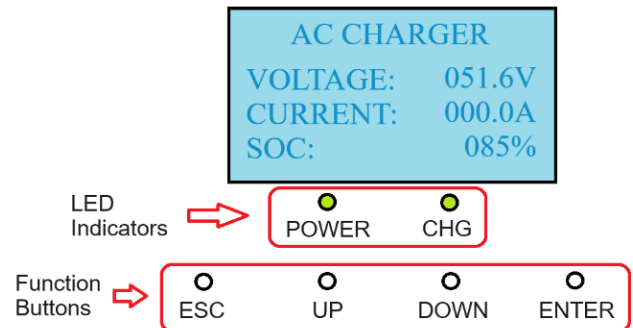

LED Indicator			Mode
Label	Color	Status	
POWER	Green	Solid ON	The unit is powered ON
		Flashing	Battery is charging
CHG	Green	Solid ON	Battery is fully charged

Function Button	Description
ESC	To exit Setting mode
UP	To increase the currently selected parameter. To go to the next selection to the left when navigating in the SETTINGS mode. <b>Note:</b> The button shows an up-arrow, but the function is “left” for navigating.
DOWN	To go to the next selection to the right when navigating in the SETTINGS mode. <b>Note:</b> The button shows a down-arrow, but the function is “right” for navigating.
ENTER	To confirm the selection in Setting mode or to enter Setting mode.

## 6.2.1 LCD INTERFACE

Operation and control of the Chargeverter-GC is facilitated through an LCD interface on the front panel. Press any button to wake up the LCD interface. The main screen (shown to the right) displays the charger’s voltage, current, and SOC values. The SOC is only displayed when the charger is connected to a battery via RS485 and is receiving SOC information. This screen is informational only and no changes can be made.

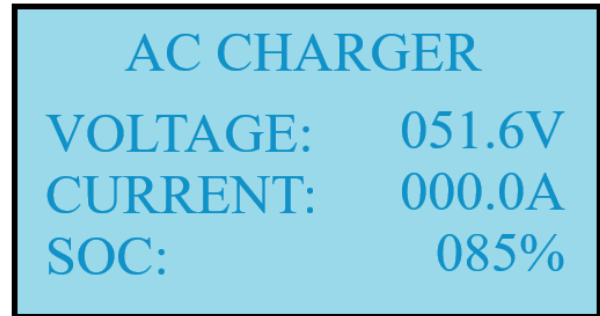

The main screen will display “LOST” for the SOC value when the charger is not connected to a battery via RS485 and is not receiving SOC data.

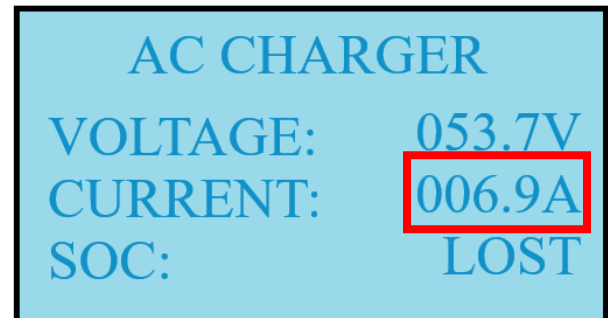

Press the "ENTER" button to activate the “SETTINGS” mode as shown to the right. Use the “UP/DOWN” buttons to scroll left/right, respectively, through the adjustable parameters. The table below describes the various parameters and Section 6.2 details how to make adjustment to the parameter settings.

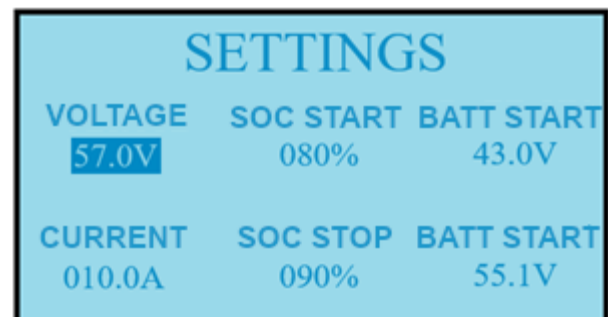

Parameter	Description	Applications	Details
<b>Voltage (V)</b>	Charging Voltage	This parameter is used with and without a generator to set the charging voltage.	This is the voltage used to charge the batteries. The setting range is 43V to 57V in 1-digit increments per value. The default setting is 54V.
<b>SOC START</b>	SOC Threshold	This parameter is used only when a generator is supplying AC power to the charger.	When the battery SOC is less than the SOC START, the dry contacts NO & C are closed and NC & C are open. This turns the generator ON. The setting range is 1% to 100% in 1% increments.
<b>BATT START</b>	Battery Under-Voltage Threshold	This parameter is used only when a generator is supplying AC power to the charger.	When the battery voltage is lower than BATT START, the dry contacts NO & C are closed and NC & C are open. This turns the generator ON. The setting range is 43V to 57V in 1-digit increments per value
<b>Current (A)</b>	Charging Current	This parameter is used with and without a generator to set the charging current.	This is the current used to charge the batteries. The setting range is 0A to 100A in 1A increments.
<b>SOC STOP</b>	SOC STOP	This parameter is used only when a generator is supplying AC power to the charger.	When the battery SOC is higher than SOC STOP, the dry contacts NO & C are open and NC & C are closed. This turns the generator OFF. The setting range is 1% to 100% in 1% increments.
<b>BATT STOP</b>	Battery Over-Voltage Threshold	This parameter is used only when a generator is supplying AC power to the charger.	When the battery voltage is higher than BATT STOP, the dry contacts NO & C are open and NC & C are closed. This turns the generator OFF. The setting range is 43V to 57V in 1-digit increments per value



**NOTE:** SOC START should always be less than SOC STOP. BATT START should always be less than BATT STOP

## 6.2.2 LCD PARAMETER SETTINGS

The following table provides detailed instructions for modifying Chargeverter-GC parameter settings using the LCD interface.

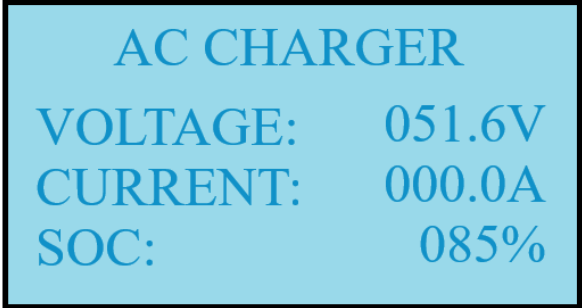
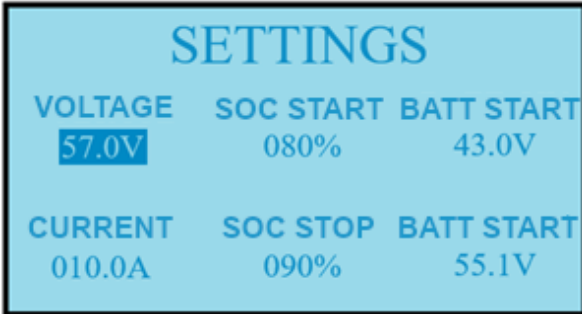
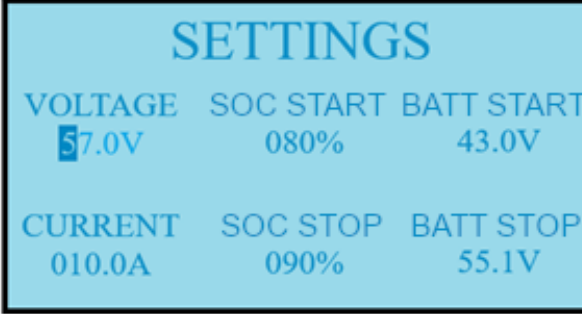
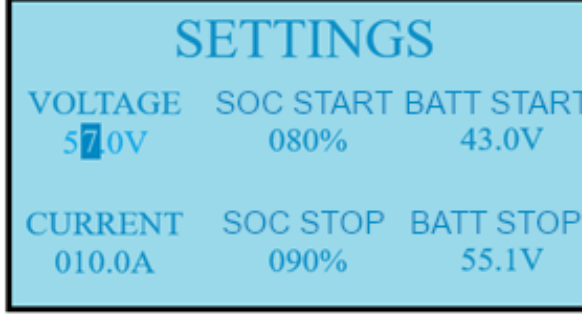

**NOTE:** When configuring the Chargeverter to charge by voltage, ensure the SOC STOP is set *before* setting SOC START or the Chargeverter will default the SOC START setting to its original value.

Description	LCD display
<p>Press “ENTER” to display the main “AC CHARGER” screen to the right. This display shows the current real-time charging Voltage, Current, and SOC. If there are no RS485 communications in place between the charger and a battery with supported BMS, SOC will be displayed as “LOST”. This screen is for informational purposes only.</p>	
<p>Press “ESC” or “ENTER” to display the “SETTINGS” screen shown to the right. The “VOLTAGE” setting will be highlighted. Press the “UP/DOWN” buttons to scroll left/right, respectively, through the various parameters.</p>	
<p>To modify a parameter, scroll to the desired parameter (in this case, VOLTAGE as shown above). Press the “ENTER” button to highlight the first digit of the voltage (see screen to the right). Press the “UP” button to make changes to this digit (Do not use the “DOWN” button). Press “ENTER” to accept the changes or “ESC” to ignore them.</p>	
<p>Press the “DOWN” button to highlight the next digit of the voltage (see screen to the right). Press the “UP” button to make changes to this digit (Do not use the “DOWN” button). Press “ENTER” to accept the changes or “ESC” to ignore them.</p>	

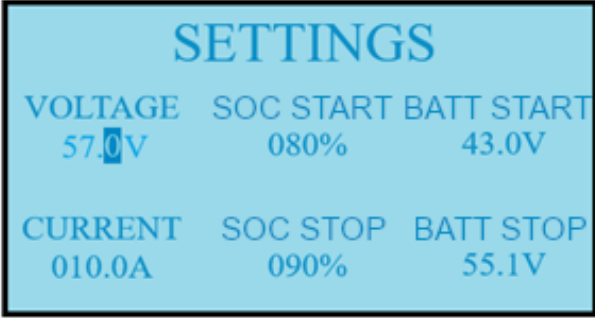
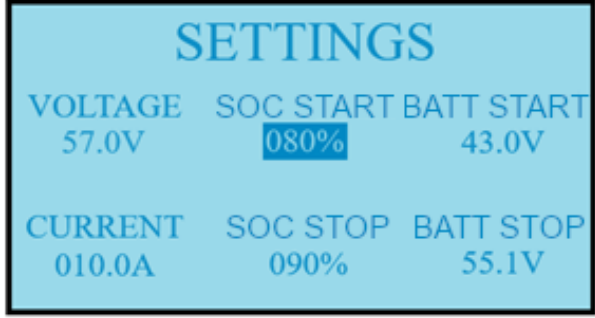
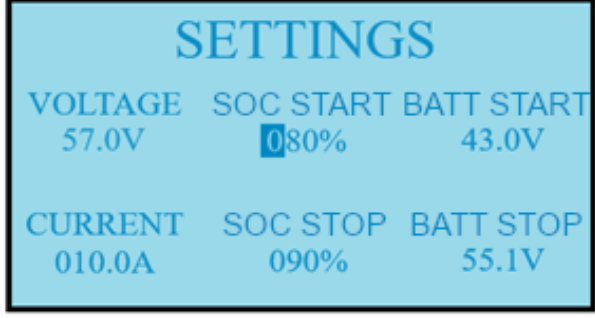
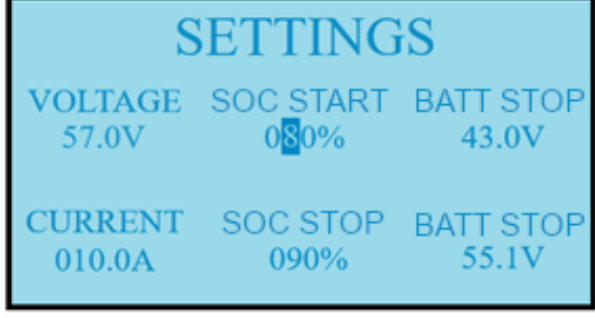
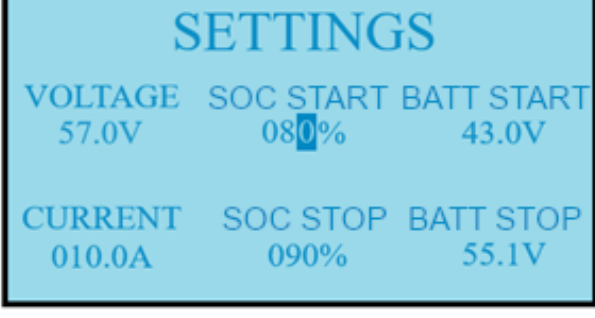
<p>Press the “DOWN” button to highlight the next digit of the voltage (see screen to the right). Press the “UP” button to make changes to this digit (Do not use the “DOWN” button). Press “ENTER” to accept the changes or “ESC” to ignore them.</p>	
<p>Press the “DOWN” button to highlight the SOC THRES setting (see screen to the right).</p>	
<p>Press the “ENTER” button to highlight the first digit of the SOC THRES parameter. Press the “UP” button to make changes to this digit (Do not use the “DOWN” button). Press “ENTER” to accept the changes or “ESC” to ignore them.</p>	
<p>Press the “DOWN” button to highlight the next digit of the SOC THRES (see screen to the right). Press the “UP” button to make changes to this digit (Do not use the “DOWN” button). Press “ENTER” to accept the changes or “ESC” to ignore them.</p>	
<p>Press the “DOWN” button to highlight the next digit of the SOC THRES (see screen to the right). Press the “UP” button to make changes to this digit (Do not use the “DOWN” button). Press “ENTER” to accept the changes or “ESC” to ignore them.</p>	

Press the "DOWN" button to highlight the BATT START setting and repeat the steps above to make and save changes to the BATT START parameter.

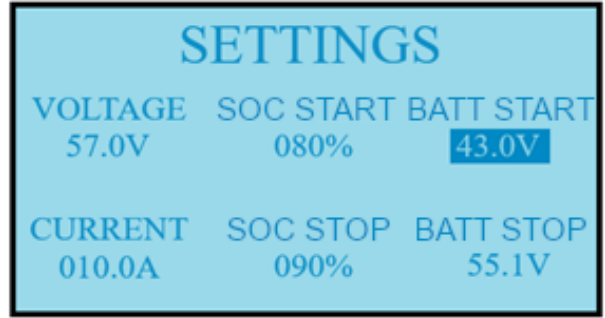

Repeat the steps above to make and save changes to the CURRENT, SOC STOP, and BATT STOP parameters, as needed.

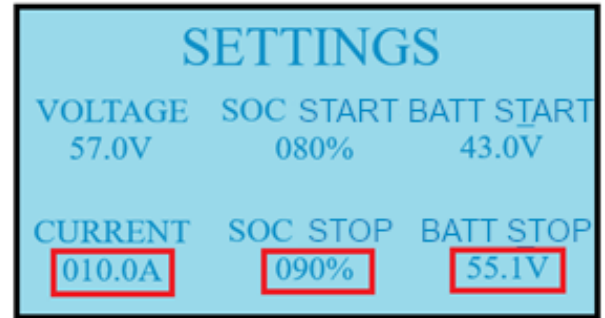



## 6.3 CHARGER COMMUNICATIONS

The Chargeverter-GC includes the option to connect the charger to a properly equipped battery for communications over RS485. The charger will ping the battery to get the SOC/Voltage status and use that information to start and stop generator charging at the preset thresholds. These thresholds are adjustable via the SETTINGS display.

If there are no communications between the charger and a battery, the battery voltage is used to start and stop generator charging at preset voltage thresholds (BATT START and BATT STOP, respectively). These voltage thresholds are also adjustable via the SETTINGS display.



**CAUTION: Do NOT establish communication between the charger and a battery or batteries that already have communication with an inverter. Batteries should never have communications with a charger and an inverter at the same time.**

The following table and diagram show the connections necessary to facilitate charger-to-battery communications using the RS485 communication cable provided with the charger. The EG4 LL Series battery is used in this example for convenience. Connect the RS485 cable between the RJ45 jack on the right side of the charger (labeled “RS485”) and the RJ45 jack on the battery (labeled RS485).

RS485 JACK PIN-OUT	
RJ-45 Pin	Description
1	RS485-1-B
2	RS485-1-A
3,4,5,6,7,8	NC=No Connection

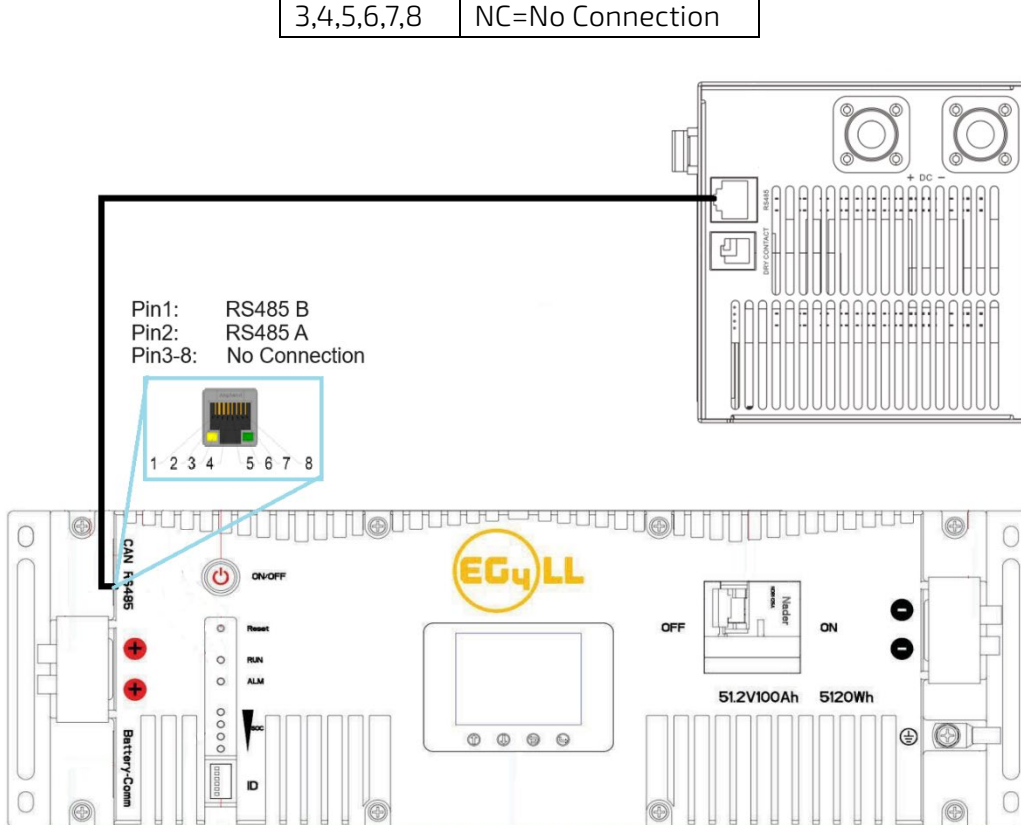

## 6.4 DRY CONTACT DESCRIPTION

There are dry contacts available from the RJ11 jack on the right side of the charger to control a generator. The RJ11 jack has 6 pins used in pairs to provide a Normally Open (NO) signal, a Common (C), and a Normally Closed (NC) signal. The jack and plug pin locations are identified in the figures to the right and the wiring and pinout details for the dry contact cable included with the charger are identified in the table below.

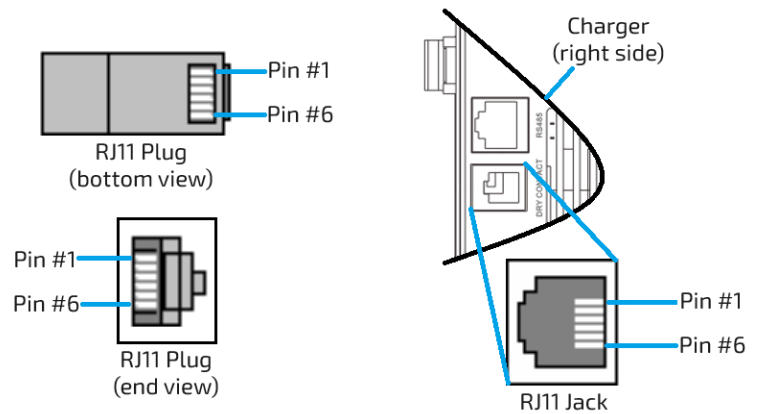

RJ11 PIN #	1	2	3	4	5	6
Wire Color	Yellow	Brown	Blue	Green	Red	Black
Function	Normally Open (NO)		Common (C)		Normally Closed (NC)	

These signals can be used to control a generator based on user defined thresholds of battery SOC or Voltage. If the charger has communication with the battery, SOC is the priority and is available for charging start/stop thresholds. If there are no communications between the charger and battery, SOC readings are not available, and voltage is used as the charging start/stop threshold. See section 6.3 for more information on dry contact use for generator control.

UNIT STATUS (1)	BATTERY CONDITION	DRY CONTACT PORT	
		NO & C (2)	NC & C (2)
Power OFF	Unit is OFF	Open	Closed
Power ON, Charger to Battery Comms used	Battery SOC < SOC START	Closed (Generator ON)	Open
	Battery SOC > SOC STOP	Open (Generator OFF)	Closed
Power ON, Charger to Battery Comms <u>not</u> used (No SOC)	SOC THRES < Battery SOC < SOC STOP	Closed while charging (Generator ON) Open while discharging (Generator OFF)	Open while charging Closed while discharging
	Battery Voltage < BATT START	Closed (Generator ON)	Open
	Battery Voltage > BATT STOP	Open (Generator OFF)	Closed
Power ON, Charger to Battery Comms <u>not</u> used (No SOC)	BATT START < Battery Voltage < BATT STOP	Closed while charging (Generator ON) Open while discharging (Generator OFF)	Open while charging Closed while discharging

(1) Power provided to unit with AC power (120, 208, or 240VAC) or DC power from batteries (~48 VDC)

(2) NC = Normally Closed, NO = Normally Open, C = Common

## 6.5 WORKING WITH A GENERATOR

The Chargeverter-GC dry contacts are specifically designed to interface with a generator. The charger AC input is simply plugged into the generator 240 VAC output and the dry contacts are used to start/stop the generator based on user defined thresholds of battery SOC or voltage. During this mode of operation, the charger is powered from the battery's DC voltage.

The following diagram shows the connections necessary to use the generator and the charger to charge the batteries. When the battery SOC or voltage (\*) reaches the user defined 'ON' threshold (SOC START and BATT START., respectively), the Normally Open (NO) dry contacts will close, signaling the generator to turn ON. Once the battery SOC or voltage reaches the user defined 'OFF' threshold (SOC STOP and BATT STOP, respectively) the Normally Open (NO) dry contacts will open, signaling the generator to turn OFF.



**\*NOTE:** If charger-to-battery communications are being used, SOC will be used as the charging ON/OFF thresholds (SOC START and SOC STOP, respectively). If charger-to-battery communications are not being used, voltage will be used as the charging ON/OFF thresholds (BATT START and BAT STOP, respectively).

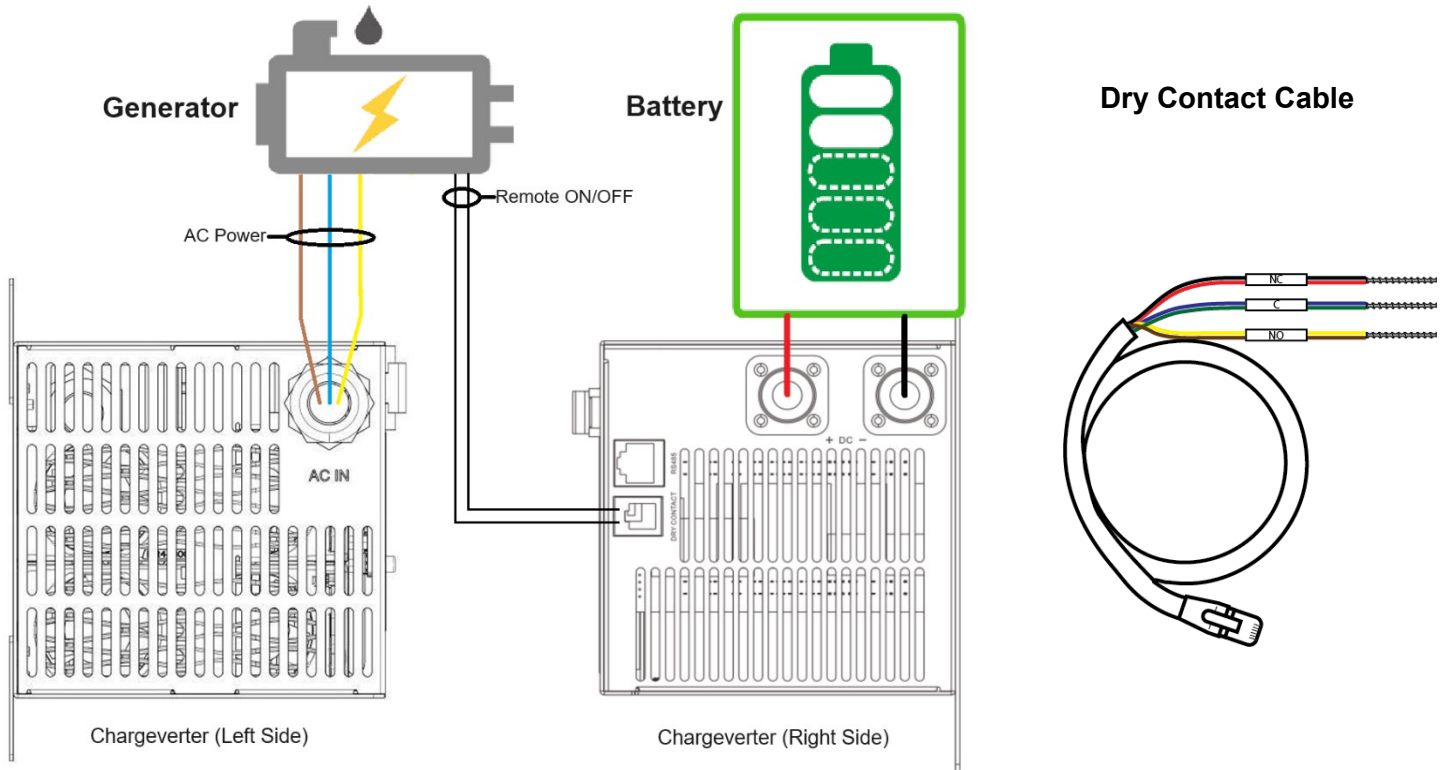

**CAUTION!** The Chargeverter is *not* meant to run in tandem with the inverter while powering loads. If for any reason the batteries did not hit the set SOC or voltage point, the Chargeverter can drain the generator's fuel source, resulting in damage to the equipment and/or personnel. EG4 highly recommends turning off the Chargeverter if there are no plans on using the generator for extended periods of time to avoid any phantom loads.

The following table shows the Generator ON/OFF status based on the user defined thresholds and the Normally Open (NO) dry contacts on the Chargeverter-GC. SOC is used if charger/battery communications are being used. Voltage is used if SOC is not available.

<b>Battery Condition</b>	<b>NO Contact (reference to common)</b>	<b>Generator Status</b>
Battery SOC < SOC START	Closed	ON
Battery SOC > SOC STOP	Open	OFF
SOC START < Battery SOC < SOC STOP	Closed while charging Open while discharging	ON while charging OFF while discharging
Battery Voltage < BATT START	Closed	ON
Battery Voltage > BATT STOP	Open	OFF
BATT START < Battery Voltage < BATT STOP	Closed while charging Open while discharging	ON while charging OFF while discharging



## CONTACT US

[support@eg4electronics.com](mailto:support@eg4electronics.com)

+1 (903) 609-1988

[www.eg4electronics.com](http://www.eg4electronics.com)