

These Instructions are for the installation of an Engine Synchronizer Kit, consisting of Gauge, Module, and Harness. It is designed for use with Tachometers manufactured by Veethree (USA). The gauge may be of nominal 2" or 3" size, and have one mounting stud (Figure 1A), or two mounting studs (Figure 1B).

CAUTION:

READ AND FOLLOW THESE INSTRUCTIONS CAREFULLY BEFORE PROCEEDING WITH INSTALLATION. DO NOT DEVIATE FROM WIRING INSTRUCTIONS. INCORRECT INSTALLATION COULD CAUSE ELECTRICAL SHORT WITH POSSIBLE FIRE. ALWAYS DISCONNECT BATTERY BEFORE MAKING ANY ELECTRICAL CONNECTIONS.

NOTE: VARIOUS STANDARD-MAKING ORGANIZATIONS HAVE PROMULGATED RULES FOR WIRING. THOSE APPLICABLE TO YOUR SITUATION SHOULD BE FOLLOWED.

Additional Supplies Required:

- No. 16 Stranded Insulated Wire
- Insulated terminal lugs as required

MOUNTING THE GAUGE

1. Select a mounting location for the Gauge which provides easy readability from the operator's position. Check behind the mounting location for installation clearance. A suitable mounting area for the Module must also be available. This mounting must be within reach of the optional 24" (609 mm) harness P/N 1471175 if used.
2. Cut a 2-1/8" (54 mm) or 3-13/32" (86.5 mm) diameter hole through the panel at location selected.
3. Insert Gauge through the hole, and secure with U-shaped bracket, using the nuts and washers provided. See Fig. 1. Bracket is designed for use with 1/2" (13 mm) maximum thickness panels. Legs may be shortened if required.

CAUTION: DO NOT OVER-TIGHTEN NUTS, OR YOU MAY CRACK THE GAUGE HOUSING OR THE MOUNTING PANEL.

MOUNTING THE MODULE

1. Mount Synchronizer Module at location previously selected, using the screws provided.

WIRING

1. Refer to Figures 2A through 2C and determine which style gauge you have. If you have the style shown in Fig. 2A, run a wire from the "G" terminal of Gauge to "IGN" terminal of ignition switch.
2. For types shown in Fig. 2B and 2C, run a wire from "IGN" terminal of Gauge to "IGN" terminal of ignition switch or "IGN" terminal of another Gauge.

FIGURE 1A
ONE STUD STYLE

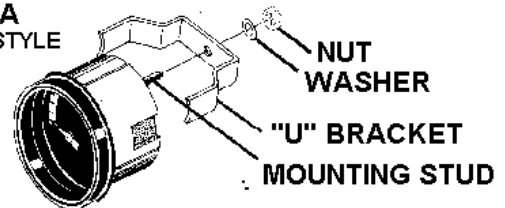

FIGURE 1B
TWO STUD STYLE

NOTE: FACE OF YOUR GAUGE MAY DIFFER FROM DRAWINGS.

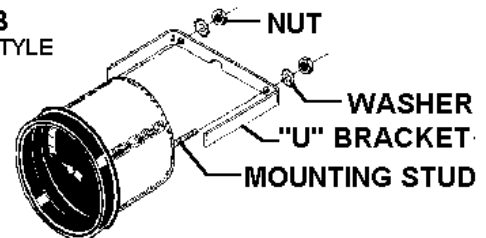

FIG.2A
(2")

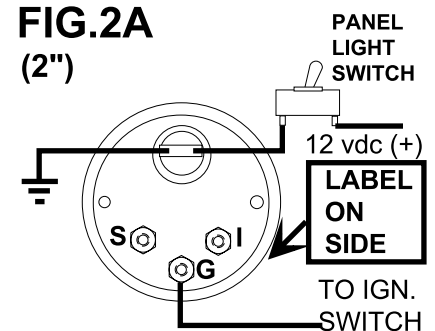

FIG.2B
(2")

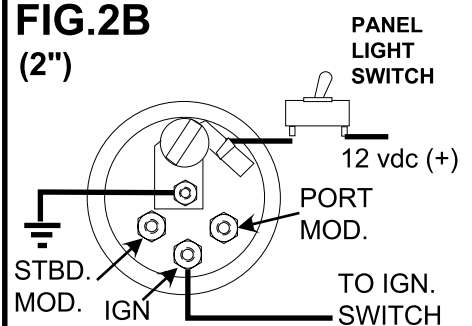
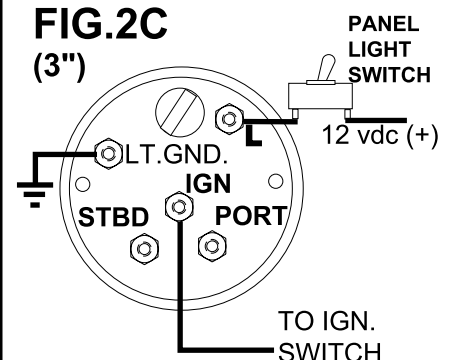

FIG.2C
(3")



3. If lighting is desired:

A. Type 2B and 2C: (Twist-in wedge base lamp) Run a wire from the LT (Light) terminal of Gauge to panel light switch or LT terminal of another Gauge. Run a wire from "LT GND" (Type 2C) or mounting stud terminal (Type 2B) to electrical system ground.

B. Type 2A: Connect one lead from lamp socket to panel light switch or LT terminal of another Gauge, and the second to electrical system ground.

4. Refer to Figure 3. Wiring shown will cause Gauge pointer (for types shown in Figures 2A and 2B) to move in direction of faster engine. Type shown in Figure 2C will move towards slower engine. If desired, this may be changed by reversing connections at Module shown below and in Figure 3 A and B.

A. Run a wire from sender (S) terminal of Starboard Tachometer to Starboard engine tach terminal of Module.

B. Run a wire from sender (S) terminal of Port Tachometer to Port engine tach terminal of Module.

5. Run a wire from Ground terminal of Module to electrical system ground.

6. Refer to Figure 4, A through D, for your style gauge.

For Types A, B, and C, connect Wiring Harness from Module to Gauge as shown in appropriate section of Figure 4, making sure plugs are fully seated on terminals.

For Type D, cut molded plug off one end of harness. Install insulated ring terminals (not furnished) on leads of harness and connect to gauge as shown in Figure 4D.

Dual Station Applications:

The preferred method is to use a Module for each gauge. The alternative is to use one Module, and wire the Gauges in parallel - that is, Ign to Ign, Port to Port, Stbd to Stbd. In this case, the Jumpers (Figure 3) **must** remain in place.

When wiring is completed, reconnect Battery. Turn both keys On - - Gauge pointer should be centered. If there is a problem, check electrical connections. Be sure IGN and GRD connections are not reversed.

CAUTION:

BEFORE RECONNECTING BATTERY, RECHECK WIRING TO ENSURE ALL CONNECTIONS ARE PROPERLY MADE. INCORRECT CONNECTIONS OR ELECTRICAL SHORTS COULD CAUSE DAMAGE OR FIRE. ELEMENTS OF ELECTRICAL SYSTEMS SHOULD HAVE PROPER FUSES INSTALLED.

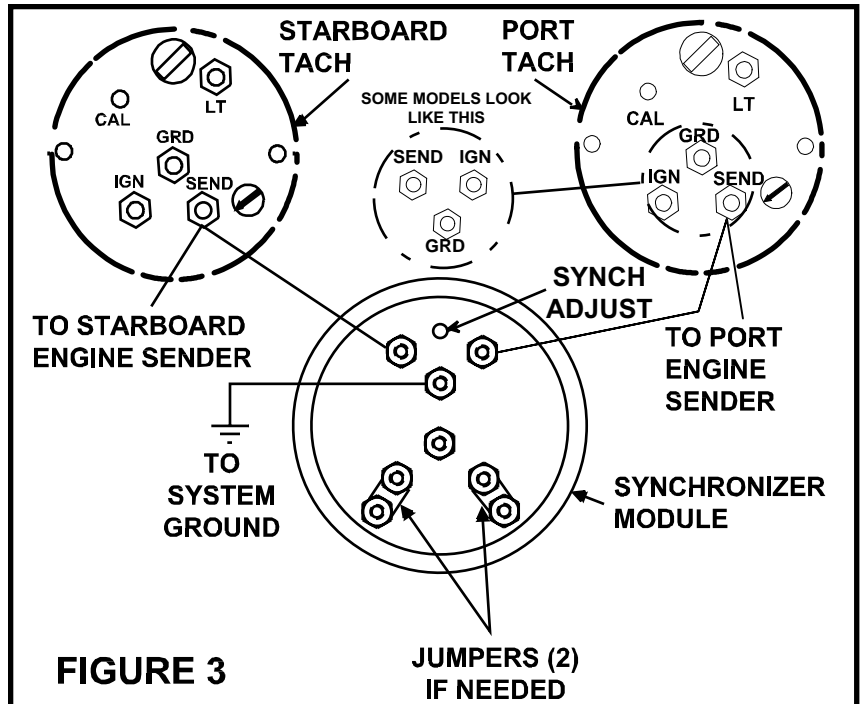

FIGURE 3

**JUMPERS (2)
IF NEEDED**

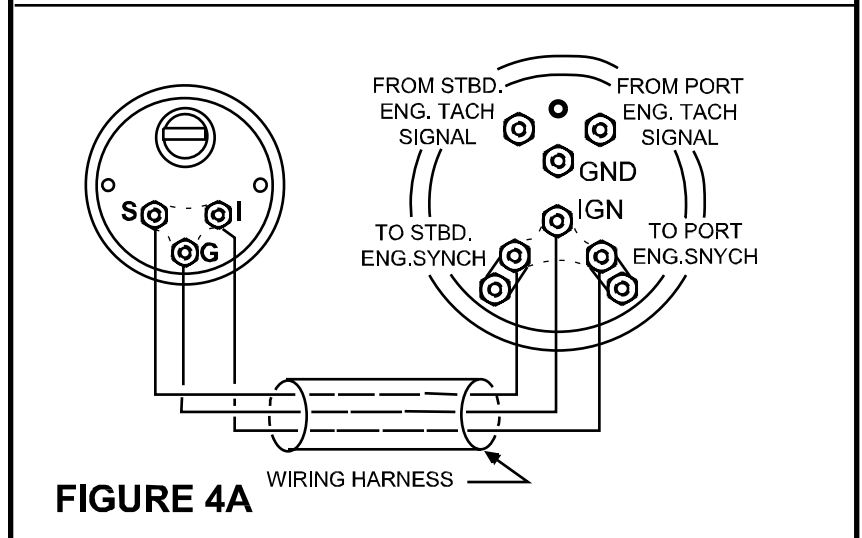

FIGURE 4A

WIRING HARNESS

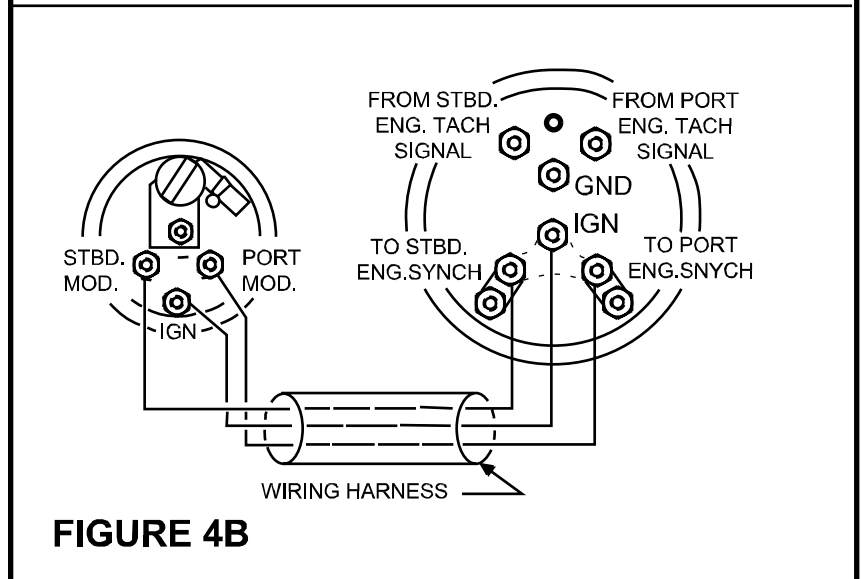

FIGURE 4B

WIRING HARNESS

OPERATION AND CALIBRATION

1. Start engines and observe readings of Tachometers and Synchronizer Gauge. Equal positioning of throttle levers should produce a center reading on Synchronizer Gauge. Pointer will deflect to side which has greater engine speed (except for Type 2C).

2. The Gauge and Module are calibrated for extreme accuracy in detecting differences in engine speeds. In some cases, it may be necessary to decrease the sensitivity of the unit. Removal of the Jumper tabs (See Figure 3) on the Module will decrease sensitivity as shown on the Gauge. This means a greater difference of engine speeds will be required for an equal deflection of the Gauge pointer. If your application uses two Gauges from one Module, the Jumpers **must not be removed.**

3. In extremely rare cases, it may be necessary to calibrate the unit. Make sure both engines are running at the same speed. Temporarily remove the dust cover and insert a small bladed screwdriver in the calibration hole in the Module marked "SYNCH ADJUST". (See Figure 3). Rotate the adjustment screw in very small increments to change Gauge pointer deflection from either side of center. Do Not over-torque the adjustment or you will damage the Module.

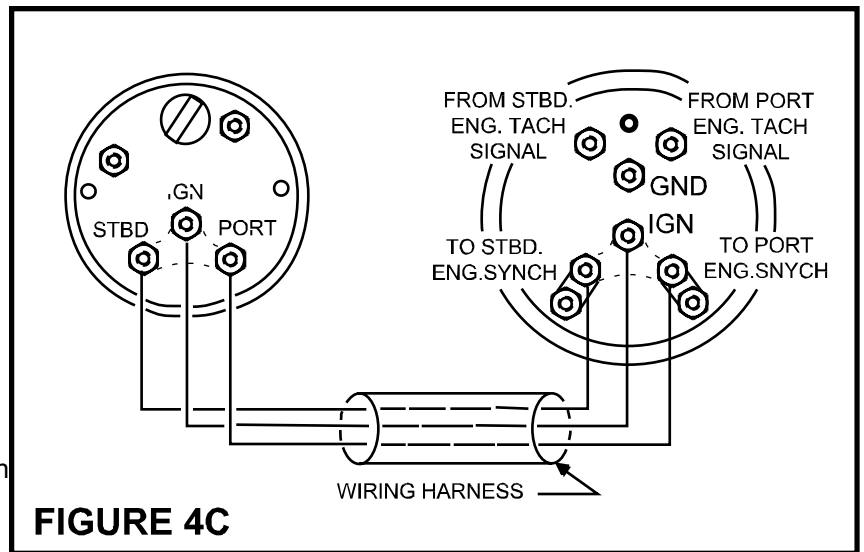

FIGURE 4C

USA Sales/Support
Veethree Electronics and Marine
2420 Trailmate Drive
Sarasota, FL 34243, USA
Tel 941/538-7775
Fax 941/775-1222
techservice@veethree.com
www.V3instruments.com