

L6349
BARBIE FORD MUSTANG
12 VOLT ADVANCED SERIES

| | |
|-------------------|--|
| Age Range: | 3-7 Years |
| Weight Limit: | 130 lbs. |
| Surfaces: | Hard and Grass |
| Speed: | 2.5 MPH Forward/Reverse 5.0 MPH Forward |
| Colors: | Pink Body, Black Wheels |
| Intro: | 2007 |
| Suggested Retail: | \$269.99 |
| Box Dimensions: | 30.9 X 18.4 X 51.8 72.6 LBS |
| Warranty: | One Year Vehicle Six Months Battery |

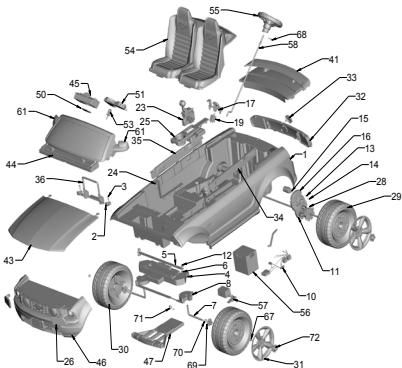

| ITEM | PART # | DESCRIPTION | QTY | ITEM | PART # | DESCRIPTION | QTY |
|-----------|-------------------|--------------------------------------|-------------|------|------------|---------------------------------------|------|
| 1 | N/A | BODY | 1 EA | 35 | N/A | RIGHT INSIDE DOOR | 1 EA |
| 2 | N/A | PIVOT RETAINER | 2 EA | 36 | 3800-7809 | BATTERY RETAINER | 1 EA |
| 3 | N/A | SCREW, SELF TAPPING | 6 EA | 41 | L6349-9419 | REAR DECK W/ SPOILER | 1 EA |
| 4 | L6349-2119 | FRONT MODULE | 1 EA | 43 | L6349-9459 | HOOD ASSY. | 1 EA |
| 5 | J4390-4009 | CROSS BAR | 1 EA | 44 | L6349-9709 | WINDSHIELD ASSY. | 1 EA |
| 6 | 0801-0196 | 7/16 FLAT WASHER | 2 EA | 45 | J4390-9619 | SOUNDBOX ASSY. | 1 EA |
| 7 | J4390-4509 | FRONT AXLE | 2 EA | 46 | L6349-9809 | FRONT BUMPER W/LIGHTS & GRILL | 1 EA |
| 8 | J4390-9159 | STEERING LINKAGE ASSY. | 1 EA | 47 | L6349-2829 | FRONT BUMPER SUPPORT | 1 EA |
| 10 | J4390-9799 | MAIN WIRING HARNESS | 1 EA | 50 | N/A | BATTERY DOOR ASSY | 1 EA |
| 11 | 00968-2801 | GEARBOX ASSY. | 2 EA | 51 | N/A | SOUNDBOX COVER | 1 EA |
| 12 | 0801-0226 | .437 CAP NUT | 2 EA | 53 | J4390-2649 | SOUNDBOX KEY | 1 EA |
| 13 | 00801-0196 | M3-.5 X 32MM NYLON SCREW | 2 EA | 54 | L6349-9759 | SEAT ASSY. | 1 EA |
| 14 | N/A | M3-.5 X 32 MM SLOT SCREW | 1 EA | 55 | L6349-9769 | STEERING WHEEL ASSY. | 1 EA |
| 15 | 00968-2707 | MOTOR PINION ASSY. | 2 EA | 56 | 00801-0638 | 12V BATTERY | 1 EA |
| 16 | 00968-2941 | MTGBX ASSY. | 2 EA | 57 | 00801-1480 | 12V PROBE CHARGER | 1 EA |
| 17 | L6349-9309 | FOOTBOARD ASSY | 1 EA | 58 | J4390-4409 | STEERING COLUMN | 1 EA |
| 19 | 00801-0923 | SWITCH-ROCKER | 2EA | 61 | 3800-8227 | RIGHT/LEFT MIRRORS/ HOUSING/COVERS | 1 EA |
| 23 | J4390-9209 | SHIFTER ASSY. | 1 EA | 67 | 00905-0116 | 3/8"-16 LOCK NUT | 2 EA |
| 24 | L6349-2259 | WIRE COVER | 1 EA | 68 | 00801-1565 | 5/32-X 1 1/2 PIN | 1 EA |
| 25 | L6349-2469 | CENTER CONSOLE | 2 EA | 69 | B9785-2229 | .437 BUSHING | 2 EA |
| 26 | N/A | HEADLIGHT COVER | 2 EA | 70 | 0801-0196 | WASHER | 2 EA |
| 28 | J4390-2269 | WHEEL DRIVER | 2 EA | 71 | 00801-1620 | FASTENER CAP | 1 EA |
| 29 | J4390-2279 | LEFT WHEEL (rear uses .437 cap nut) | 2 EA | 72 | J4390-2329 | HUBCAP | 4 EA |
| 30 | J4390-2289 | RIGHT WHEEL (rear uses .437 cap nut) | 2 EA | | | | |
| 31 | J4390-6319 | WHEEL COVER | 4 EA | | | | |
| 32 | 3800-8228 | TAILLIGHT ASSY. | 2 EA | | | | |
| 33 | L6349-6409 | GAS CAP | 1 EA | | | | |
| 34 | N/A | LEFT INSIDE DOOR | 1 EA | | | | |

7/30/2015

PARTS NOT SHOWN

| | | |
|------------|------------------------------|---|
| J4390-4519 | REAR AXLE | 1 |
| L6349-9259 | PARTS BAG | 1 |
| L6349-9269 | HARDWARE BAG | 1 |
| J4390-2479 | EXHAUST PIPE RIGHT | 1 |
| J4390-2909 | EXHAUST PIPE LEFT | 1 |
| L6349-5339 | SEATBELT SET | 1 |
| 00801-1567 | ASSEMBLY TOOL (WRENCH) 9/16" | 1 |

PARTS NOT SHOWN

| | | |
|-------------------|-----------------------------|----------|
| L6349-2789 | STEERING WHEEL CAP | 1 |
| N/A | DRIVING LIGHTS | 2 |
| L6349-0310 | MAIN DECAL | 1 |
| J4390-0320 | MYLAR DECAL | 1 |
| L6349-0920 | MANUAL | 1 |
| 00801-1566 | FOOTSWITCH (PLUNGER) | 1 |
| J4394-9059 | BATTERY LIFE INDICATOR | 1 |
| 00801-1518 | PW EMBLEM | 1 |

Bold and underlined parts are to be purchased and installed by Service Centers only. These items may not be sold directly to consumers by Service Centers or Fisher-Price.