

# USER MANUAL

AirBuddy ARB-01

ENG - V04, 01/22

Original Instructions



 **WARNING**

- Before any use of this product you must carefully read and understand all the instructions for use.
- Get familiar with the proper use of this product and its capabilities and limitations.
- This product is designed for recreational surface supplied diving only.
- Diving is inherently dangerous. You must understand and accept the risks involved before participating in diving.
- Dive training is required prior to use of this product.
- You are responsible for your own actions and decisions.
- Failure to read and follow these warnings may result in serious injury or death!



## COPYRIGHT NOTICE

© Copyright OXY Pty Ltd. All rights reserved.

This material and its content is the property of OXY Pty Ltd and is protected by copyright, trademark and other intellectual property laws. You may use this material only for personal use, provided that you maintain all copyright, trademark and other proprietary rights or notices. Any other use, reproduce, distribute, store, post, broadcast, transmit, modify or sell to public is prohibited without the prior written permission of OXY Pty Ltd.

## TRADEMARK

AirBuddy® is the registered trademark of OXY Pty Ltd. The AirBuddy trademark registration confers exclusive rights to the use of the registered trademark. Therefore, the trademark and the AirBuddy logo may not be used without the prior written approval of OXY Pty Ltd, an Australian Registered Company.

## ORIGINAL INSTRUCTIONS, TRANSLATIONS AND UPDATES

The original document is written in English. Any misinterpreted information translated in other languages will not be held against OXY Pty Ltd.

Any information contained in this document is not permanent, and, therefore, it is legible for change. For the latest version of this manual, please check the website [www.airbuddy.com](http://www.airbuddy.com) or contact the manufacturer at [info@airbuddy.com](mailto:info@airbuddy.com).

## PRODUCT WARRANTY

For warranty information, please refer to the section “Warranty Policy” or refer to [www.airbuddy.com](http://www.airbuddy.com).

## COMPLIANCE AND MARKING

AirBuddy (SSBA - Surface Supplied Breathing Apparatus) is a battery-powered diving compressor that has been developed according to the directives, regulations and standards of the European Union, USA, Australia and New Zealand. AirBuddy has been tested in accredited laboratories and holds the following certifications and marking:



FCC Statement:

*This device complies with part 15 of the FCC rules. Operation is subject to the following two conditions: (1) this device may not cause harmful interference, and (2) this device must accept any interference received, including interference that may cause undesired operation.*

*This equipment has been tested and found to comply with the limits for a Class B digital device, pursuant to part 15 of the FCC Rules. These limits are designed to provide reasonable protection against harmful*

*interference in a residential installation. This equipment generates, uses and can radiate radio frequency energy and, if not installed and used in accordance with the instructions, may cause harmful interference to radio communications. However, there is no guarantee that interference will not occur in a particular installation. If this equipment does cause harmful interference to radio or television reception, which can be determined by turning the equipment off and on, the user is encouraged to try to correct the interference by one or more of the following measures:*

- *Reorient or relocate the receiving antenna.*
- *Increase the separation between the equipment and receiver.*
- *Connect the equipment into an outlet on a circuit different from that to which the receiver is connected.*
- *Consult the dealer or an experienced radio/ TV technician for help.*

**Warning:** *Changes or modifications to this unit not expressly approved by the party responsible for compliance could void the user's authority to operate the equipment.*

# Contents

INTRODUCTION .....	9
Dangers, warnings, cautions and notes .....	9
Use of this manual .....	9
GENERAL INFORMATION .....	10
Legal liability waiver & assumption of risk .....	10
SAFETY INFORMATION .....	12
General safety information.....	12
Safety information concerning users.....	12
Safety information concerning gear .....	12
Safety information concerning electricity .....	13
Safety conclusion .....	14
Medical declaration .....	14
Environmental awareness.....	14
SPECIFICATIONS.....	15
UNBOXING AIRBUDDY .....	18
INITIAL ASSEMBLY .....	19
BEFORE DIVING.....	22
Introduction.....	22
Key rules for diving with AirBuddy.....	22
GEAR PREPARATION .....	23
Set up AirBuddy .....	23
Set your weights .....	25
Attach the harness.....	25
GETTING READY FOR DIVING.....	27
Pre-dive check.....	27
Dive preparation .....	27
Entering the water.....	28
DIVING INSTRUCTIONS .....	30
Breathing underwater .....	30
Dive depth and dive time.....	30
Completing your dive.....	31
CONSECUTIVE DIVES.....	32
Replacing batteries .....	32
AFTER DIVING .....	33
AIR TRAVEL WITH AIRBUDDY .....	35
Air travel regulations .....	35
How to prepare for air travel.....	35
MAINTENANCE AND PERIODIC INSPECTION .....	36

Storage tips.....	36
Battery .....	36
Hose & couplers.....	36
Air reservoir .....	37
How to remove condensation water from the air reservoir.....	37
Compressor unit .....	37
Other parts.....	37
What to do if AirBuddy capsized .....	38
TROUBLESHOOTING .....	40
CONSUMER INFORMATION .....	41
WARRANTY POLICY.....	42
APPENDIX 1.....	44
Medical statement for divers.....	44



# Introduction

AirBuddy is a Surface Supplied Breathing Apparatus (SSBA) for recreational diving. It bridges the gap between snorkelling and SCUBA diving, and provides underwater lovers a lightweight, compact alternative to air cylinders.

AirBuddy runs off a rechargeable battery-powered compressor that provides fresh air from the surface for up to 55 minutes at a maximum depth of 12 metres for a single diver, and 6 metres for two.

## DANGERS, WARNINGS, CAUTIONS AND NOTES

Please pay attention to the following symbols when they appear through this document. They point out dangers, warnings, cautions and other important information.



**DANGER** - indicates important information or a situation that if ignored, would result in death or serious injury.



**WARNING** - indicates important information or a situation that if ignored, could result in death or serious injury.



**CAUTION** - indicates important information or a situation that if ignored, may result in minor to moderate injury and/or alerts against unsafe practice.

**NOTE:** indicates information, tips and advice that may inform you about a certain feature; for support of the product or against the damage of the product, or for best practice in diving.

## USE OF THIS MANUAL

You must carefully read and understand this manual in its entirety before using AirBuddy.

This manual is an informative guide for proper setup, operation, maintenance, and transport of the AirBuddy device only.

This manual does NOT, nor is intended to contain any information required for safe diving with any type of SSBA (Surface Supplied Breathing Apparatus), SCUBA (Self-contained Underwater Breathing Apparatus), or any other form of diving.

It is NOT meant to replace the role of a professional diving trainer.

It is NOT meant to replace any recognised training agency, instructor, diving course or training resources.

It is only to be used in conjunction with and in addition to obtaining professional dive training and instruction materials and is aimed for user reference only.

# General Information

## LEGAL LIABILITY WAIVER & ASSUMPTION OF RISK

This waiver between OXY Pty Ltd and the user of AirBuddy (*Surface Supplied Breathing Apparatus*) is meant to be clear, unambiguous, and straight forward.

Every AirBuddy owner and / or user is required to read and agree to this waiver, and by using AirBuddy every person is deemed to have read and agreed to this waiver, which states as follows:

- I understand and accept that diving and the use of any SCUBA or SSBA equipment, including AirBuddy, is dangerous and involves the risk of serious injury or death.
- I understand that there are inherent risks involved with diving, including, but not limited to; drowning, pulmonary barotrauma, air embolism, decompression sickness, heart attack, panic, hyperventilation, equipment failure, perils of the sea, harm caused by marine creatures (including bites), and I hereby assume any such risks.
- I will be engaging in diving entirely at my own risk. I understand that any use of AirBuddy is my choice, which I chose for my own personal benefit.
- I am aware that it is my obligation to know how to dive before using AirBuddy. I also acknowledge that having proper training is my responsibility and failure to obtain proper training could result in serious injury or death.
- I understand that OXY Pty Ltd is a manufacturer of specialized SSBA diving equipment and is not a dive training agency.
- I understand that this manual is not intended to replace any recognized agency training materials.
- I understand that even if I carefully follow the instructions in this manual it is still possible I

may be seriously injured or die from the inherent diving risks.

- I hereby expressly agree to RELEASE, DISCHARGE, AND COVENANT NOT TO SUE OXY Pty Ltd (including its directors, servants, and agents), its affiliate or subsidiary corporations, the owners, employees, contractors, agents, and associated personnel, past and present (collectively “**Released Parties**”) for any loss, claim or action which may in any way be related to the purchasing and / or using of AirBuddy. I hereby expressly agree to INDEMNIFY AND HOLD HARMLESS all of the Released Parties from any, and all claims, actions or liabilities arising in any way out of the purchasing and / or using of AirBuddy, or for any other acts or omissions on their part, including, but not limited to negligence of any type.
- I understand that AirBuddy, like any other man-made machine, could fail. I vow not to dive without a backup system, such as an egressor or pony bottle.
- As an owner of AirBuddy, I understand that I am solely responsible for the health and safety of any user of my AirBuddy. I also understand that I am responsible for any other people I take on a dive with me. It’s my responsibility to ensure they are professionally trained divers and have familiarized themselves with this manual, including this waiver, and such individual freely consents.
- I am aware of and accept the fact that AirBuddy is designed for recreational use only. I will not use AirBuddy for occupational diving, for example, as defined in the Australian and New Zealand Standards AS/NZS 2299 Occupational Diving Operations (or any other equivalent standard that may be in operation therein).
- I understand that AirBuddy does not make me a better diver and I undertake to participate in diving activities appropriate to my skill level.
- Although this waiver is to be broadly construed, I understand that this waiver does not intend to change or prohibit any liability which is not capable of being excluded by law.

- I acknowledge and agree that any terms or warranties, express or implied, relating to marketable quality or fitness for a particular purpose, or which could have otherwise resulted into a contract for the purchase of the AirBuddy by any statute or permission by law, are excluded.
- I irrevocably agree that the governing law and jurisdiction is that of NSW, Australia. Therefore, any dispute or action between OXY Pty Ltd and I will be commenced and continued under the sole and exclusive jurisdiction of NSW, Australia.
- I agree that the governing law and jurisdiction is that of NSW, Australia. Therefore, any dispute between OXY Pty Ltd and I will be under the exclusive jurisdiction of NSW, Australia.
- I acknowledge to have read the foregoing Legal Liability Waiver and Assumption of Risk Waiver, and certify that I am of legal age and am fully competent. I hereby accept and consent to this waiver which shall be binding upon myself, heirs, successors and assigns.

# Safety Information

## GENERAL SAFETY INFORMATION

Before using AirBuddy, you ought to have read and followed all the instructions to ensure the device functions properly, you are in good physical condition and you know what to expect from the environment you will be diving in.

## SAFETY INFORMATION CONCERNING USERS

You must carefully read and understand this manual before diving with AirBuddy. If you do not understand any part of it, contact our customer service immediately. Only use AirBuddy when you are 100% sure how it works and understand its capabilities and limits.

 You must have ample training from a recognised training agency before using AirBuddy. Failure to complete the training and using AirBuddy may result in injury or death!

 Only skilled and experienced divers aged 16 and older are allowed to use AirBuddy.

 AirBuddy is only to be used in accordance with safe diving practices learned during the dive training sessions.

 Do not use AirBuddy if you are pregnant, have any medical condition, have any hearing disability, or if you are under the influence of alcohol, medication or drugs.

 Never try to use AirBuddy beyond the limits of your ability or the limits of AirBuddy.

 Never dive without a backup system (e.g. egressor or pony bottle).

 Never hold your breath while diving and never ascend without exhaling air from your lungs! Expanding air could cause Pulmonary Barotrauma and/or Air Embolism (lung over expansion and rupture releasing bubbles into the bloodstream).

 Never exceed NDL (No Decompression Limit). Always complete Safety Stop(s) to avoid the risk of Decompression Sickness!

 Do not dive alone unless you are professionally trained for solo diving.

 Do not cover your ears while diving (e.g. wearing a wetsuit hood or headphones). This could decrease your hearing ability and you may miss the warning signal.

 AirBuddy should only be used in a calm environment. Avoid strong currents, rolling waves, jet channels, river streams, contaminated water, near exhaust fumes, unstable cliffs with falling rocks, or obstructed underwater environments (such as cave, wreck or kelp forest).

 Stay away from kelp, fishing lines, nets, mooring lines, anchor chains, jetties and large floating objects such as pieces of plastic or wood.

 Always use a diving computer to monitor your depth, bottom time, dive time, ascent rate, etc.

 The magnetic wristband of the AirBuddy has a strong magnet which can influence your diving compass due to the magnetic field's alteration. It can be harmful to pacemakers or neurostimulators. Keep it out of the reach of children, and avoid ingestion. To avoid damage, keep magnetic media such as computer disks, credit cards and tapes away.

**NOTE:** It is recommended to obtain accident insurance that covers diving.

## SAFETY INFORMATION CONCERNING GEAR

 Improper use or failure of this equipment may lead to an injury or death.

 Before any dive, inspect the AirBuddy and ensure all hoses and air couplers are in place. Check for any air leaks and correct system pressure. If in doubt, do not dive!

 AirBuddy has been designed and tested, both in materials and function to operate safely and

consistently. Never alter, add, remove or reshape any functional part of AirBuddy.

 Never use non-original parts in place of AirBuddy parts without the prior consent of OXY Pty Ltd. Altering, adding, removing, re-shaping or substituting any part of the AirBuddy can affect its performance and operation, possibly leading to serious injury or death.

**NOTE:** Unauthorized alterations to functional parts of AirBuddy will render factory work unwarranted, hence, no repairs or service work will be performed by authorized service professionals until brought back to factory specifications by an authorised service professional at your own expense.

 Do not submerge the unit below the lid seal. Prevent water and/or foreign objects from entering the air intake and reaching the internal components of AirBuddy.

 Do not assemble, open or disassemble the AirBuddy while in the water.

 Do not use AirBuddy to support yourself, other people, animals or foreign objects on the surface!

**NOTE:** Water ingress and internal damage by water is not covered by the warranty.

 Do not operate AirBuddy outside of water. It must float on the surface because the compressor dissipates heat in the water. Water cooling is necessary to prevent damage to the AirBuddy, thus the stop of air flow or major leakage that could endanger diver's life!

 Avoid touching any hot surfaces dissipating heat such as the compressor head, manifold or heatsink located at the bottom of the device.

 Do not use AirBuddy if it has been dropped, leaks pressure, or shows any other signs of damage.

 Do not disconnect any air hose when the system is under pressure. Release pressurised air

through the regulator (purge button) and only then disconnect hoses.

 Keep AirBuddy out of the reach of children!

 Never store AirBuddy pressurised.

 Do not store AirBuddy in direct sunlight or in closed motor vehicles parked in the sun.

## SAFETY INFORMATION CONCERNING ELECTRICITY

 Never touch the mains plug and socket with wet hands.

 Never recharge the battery when you are wet or barefoot.

 Never insert conductive metals or objects, such as a screwdriver, into the charging connector, battery terminals, wires or other electric components of the product.

 Always fully recharge the battery before using AirBuddy.

**NOTE:** Never run the battery completely flat, but have a little or full charge.

 Do not expose the battery to strong sunlight, heat or fire. Do not crush!

 Only charge the battery using the original charger supplied with AirBuddy or a charger approved by OXY Pty Ltd.

 Do not charge a damaged battery. Contact OXY Pty Ltd immediately.

 Do not clean the inside of the AirBuddy with water. It contains electrical components that may electrocute the user when it is exposed to water.

 The charging system of the AirBuddy including the battery and charger should be stored in a dry place.

 The AirBuddy should not be thrown away, but recycled. Do not make the mistake of throwing it or its battery into a fire.

## SAFETY CONCLUSION

AirBuddy is a diving product. Similar to SCUBA, with SSBA you breathe compressed air, which might be hazardous if you haven't been professionally trained.

Professional dive training, dive preparation and planning, use of redundant safety devices, along with your physical and mental health, are your best safeguard against potential discomfort or health risk.

Breathing under water can be dangerous or even deadly if you don't know the diving rules or you chose to ignore them.

Please use all materials available to you to learn, practice and acquire the required skills. Dive responsibly, know your limits and never go to a depth you don't feel comfortable to ascend from without any air supply. Wear a redundant air system, such as the Spare-Air.

There is no shame in practicing your diving skills in shallow water. You can progress deeper as you perfect your skill diving with an SSBA.

## MEDICAL DECLARATION

 Before using AirBuddy, ensure you have good physical and mental health, have undergone proper training, and you understand the potential risks of diving.

 You should be examined by your doctor before participating in diving activities. Please refer to the Medical Statement for Divers in the appendix. You should complete all sections of the Medical Statement, including the Divers Medical Questionnaire for each user of the system. You may print a copy of the form for future reference. This information may be used by your doctor or professional diving instructor to determine the legibility of your safety.

It will help to determine the extent to which you should be examined by your doctor before engaging in diving. A positive response to a question does not necessarily disqualify you from diving. It simply means that there is a pre-existing condition that may affect your safety while diving and you must seek the advice of your doctor prior to engaging in dive activities.

Please take the completed Medical Statement from appendix to your doctor.

## ENVIRONMENTAL AWARENES

Our vision is to make diving accessible to more people, so that they can explore and appreciate the beauty of our marine life.

We hope that more people fall in love with the stunning underwater world and become aware of the problems the ocean is facing. Even though the ocean is our biggest resource for life on earth, it is also the biggest dumping ground. Some of the problems oceans face include coral bleaching, over-fishing, sound pollution, crown of thorns, shark fining, etc. The ocean is an amazing environment that deserves our admiration and protection.

AirBuddy supports environmental charities, projects and organisations that engage in nature conservation and protection.

**NOTE:** As a diver, it is important to be fully aware of the impact you could potentially make on the marine environment. There are some rules that all divers should follow, including:

- Never feed, touch or chase marine life.
- Do not step on coral, touch, or stir the sediment.
- Never leave any items behind underwater. Do not litter!
- Maintain neutral buoyancy at all times.
- Do not anchor on coral reef.
- Do not collect dead or alive marine life. Take only photos, leave only bubbles.
- Do not support shark finning.
- Do not buy coral or marine life souvenirs.
- Avoid plastic.
- Join conservation projects or charities.

# Overview

## HOW AIRBUDDY WORKS?

AirBuddy is a battery-powered compressor that floats on the surface and follows you as you dive.

The rechargeable battery stores energy to power the compressor that draws fresh air from the surface and stores the pressurised air inside the reservoir (float). The pressurised air is then delivered to the diver through a hose with a regulator (mouthpiece). Excess pressure is released through an overpressure valve.

## Specifications

### GENERAL

Max Dive Depth:

- 12 m (1 diver) / 6 m (2 divers)

Max Dive Time:

- ~55 min dive (+ ~10 min reserve)

Weight:

- 9.5 kg (excl. hose, harness and regulator)

Size (including alpha flag):

- 533 x 540 x 397 mm

Size (compressor unit only):

- 240 x 300 x 150 mm

Sound Pressure Level:

- Lwa = 69.1dB (A-weighted)

Operating Water Temperature:

- 5 - 30 °C

### AIR COMPRESSOR

- 12VDC oil-less, single piston
- Rated 75 lpm at 0 bar
- Equipped with noise-reducing baffle
- Overpressure relief valve set at 2.6 bar (38 psi)
- Water-cooled to minimise adiabatic heating

### BATTERY & CHARGER

- Dual 2x 6V (2x 156 Wh) LiFePO4 battery
- Internal battery management system (BMS)
- Removable safety link for air travel
- Charger input AC 100-240V, 50/60 Hz
- Charging time 5.0 ~ 5.5h at 14.6 VDC, 4A

### AIR RESERVOIR

- 15.7 litres internal volume for optimal air delivery balance and storage of emergency air
- System pressure 2.6 bar (38 psi)

### AIR HOSE

- Made of abrasion and kink resistant, FDA-approved polyurethane
- Fitted with activated carbon filter and non-return valve

### REGULATOR & HARNESS

- Low pressure SSBA regulator (EN250 compliant)
- Replaceable neoprene vest

### KEY SYSTEM FEATURES

- ✓ Detachable magnetic switch to ensure that only you (the diver) can switch AirBuddy off.
- ✓ Low battery monitor and underwater warning signal when the battery voltage drops below a certain threshold (after about 55 min. of operation).
- ✓ 15.7 litres large air reservoir to provide emergency air for safe return to the surface.
- ✓ Pressure relief valve that limits the pressure in the system to 2.6 bar (38 psi).
- ✓ Capsize protection to about 110° tilt with the weight mass in the lower section acting as a keel and an electronic system to decrease the risk of water ingress.

- ✓ Elaborate air ways with 1x snorkel and 3x water traps to prevent splash water from reaching the diver.
- ✓ Recoil hose to stay organised, provide improved position control and smoothen out potential tugging.
- ✓ 2x lockable couplers to prevent accidental release of the air hose.
- ✓ Visible float and diving flag to mark your position to boats, fishermen, etc.



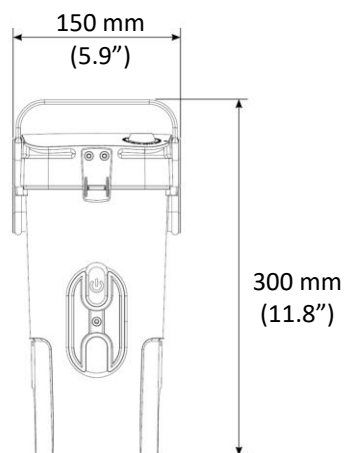
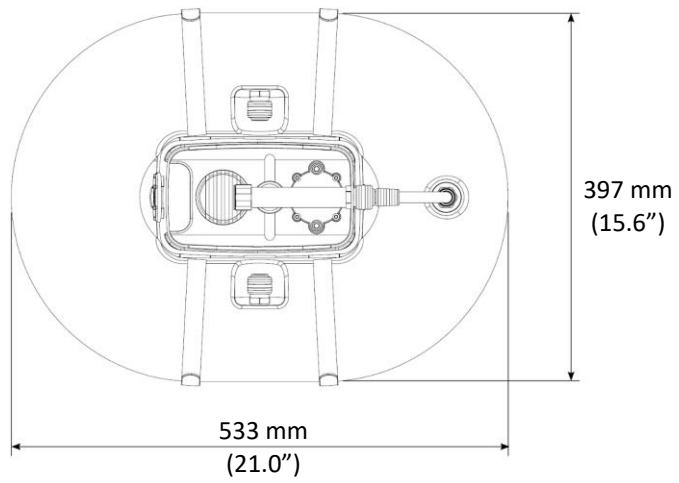
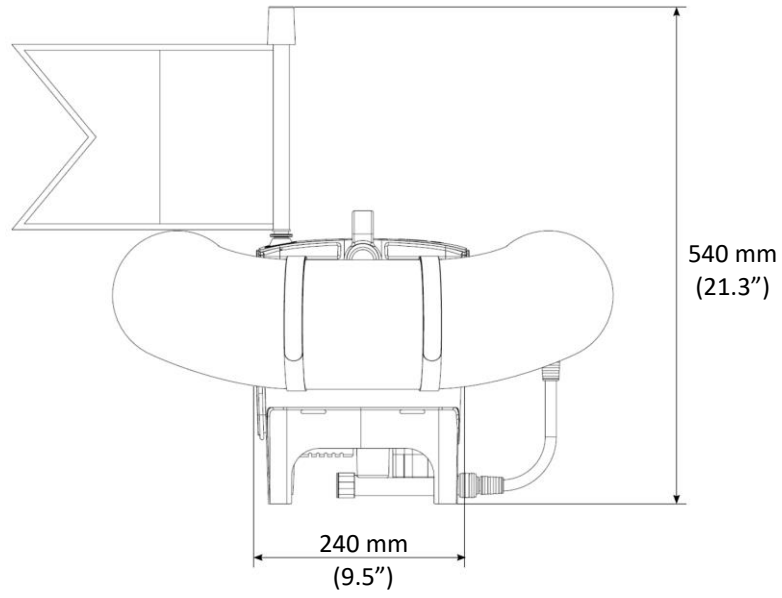

# Unboxing AirBuddy



Your AirBuddy arrived!

Your AirBuddy has been assembled and properly tested at the factory. All main components have been carefully packed in the box for safe transportation.

Open the box, remove the AirBuddy and all the accessories carefully, and place all parts on a hard, flat, clean surface. Countercheck all the parts and make sure that you have all AirBuddy accessories.

AirBuddy comes in a box with:

1. Compressor Unit, Lid and Handle
2. Magnetic Wristband
3. Air Reservoir
4. Hook and Loop Straps x4
5. Battery incl. Safety Link and Hex Key
6. Battery Travel Case
7. Battery Charger
8. Air Hose with Filter and Non-return Valve
9. Regulator
10. Harness
11. Weight Belt Strap
12. Dive Flag (Alpha / Red and White)
13. Condensation Water Removal Tube
14. Duo Diver Link
- & Other Accessories if Ordered Separately

## Initial Assembly

The AirBuddy has been assembled and tested at the factory. The battery has been disconnected from AirBuddy for safe transportation.

As soon as you receive your AirBuddy, charge the battery, insert in the AirBuddy unit and connect the wires.

**NOTE:** Please keep the original AirBuddy packaging during the warranty period. In case of a warranty claim, the AirBuddy should be sent back to the factory in the original packaging.

### Step 1: Make sure AirBuddy is off

Place the magnetic wristband in the upper slot on the air compressor unit. The red part (magnet) points up and the elastic rubber band should be stretched over to sit in the groove. In this position, the air compressor should be turned off such that the battery wires can be connected to the battery terminals.



**NOTE:** Always keep your AirBuddy switched off when not diving. AirBuddy has been designed to only operate in water. It requires water cooling. You may damage your AirBuddy if you run it outside of water.

### Step 2: Open the lid

Carefully remove the lid by (1) pulling the compression handle up and out to displace it from the attachment points on each side of AirBuddy and



(2) gently lifting the red clips on each side of the lid while pulling the lid upwards.

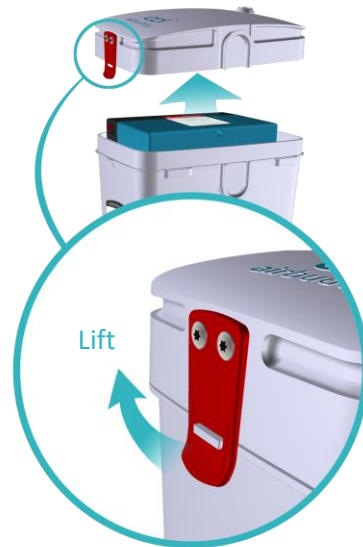

**NOTE:** Keep the lid closed at all times when using AirBuddy.

### Step 3: Install the battery (first time)

The AirBuddy has been shipped with the battery disconnected for safe transport.

Remove the battery from the air compressor unit and turn it by 180 degrees.

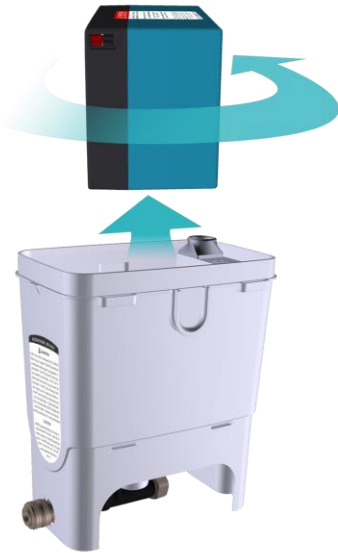

Place the battery back inside the air compressor unit with screw terminals facing the battery wires.



Unscrew the two stainless steel button-head screws from the battery and connect the battery wires. Place the lugs over the battery main terminals and fasten the screws with a 4mm hex

key. The hex key has been provided with your purchase of AirBuddy.

Your battery has been now installed and is ready for charging.

**!** Always firmly tighten the battery screws (about 3-4 Nm) to provide a good connection between the battery terminals and the AirBuddy wires. Check and fasten the battery wires before each dive.

**!** High electrical current passes from the battery to the compressor of AirBuddy through the battery wires. Proper connection of the battery wires is crucial to prevent increased electrical resistance that could lead to a potential risk of battery terminal overheating.

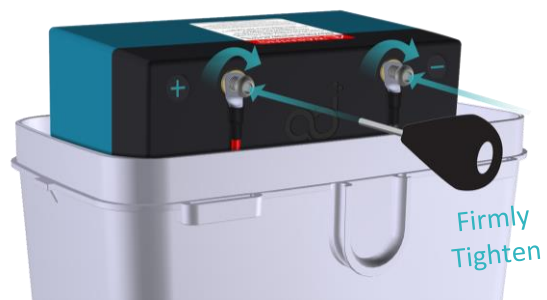

**!** Always care about the battery terminals and lugs. Prevent any contact with water (leading to oxidation), mechanical damage (e.g. scratches) or dirt (e.g. grease residues) that could impede the electrical conductivity of the connection.

### Step 4: Charge the battery

Plug charger's power lead in the power source. Then plug the charging cable into the (black and red) charging connector on the battery. Always charge the battery to full!

**NOTE:** The standard charger works with the AC power (100-240 V, 50-60 Hz). Optionally, you can purchase a charger for 12 VDC outlet to charge the battery on your boat or car.

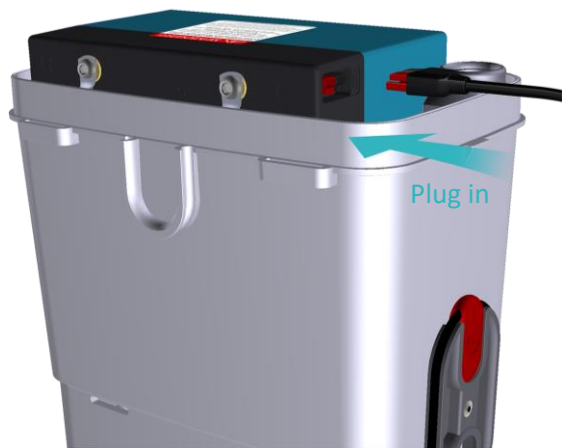

Charging of a fully depleted battery takes about 5.5 hours. The led indicator light on the charger will turn from red to green as soon as the battery is fully charged.

**NOTE:** The maximum operating time for AirBuddy is about 55 minutes (+ about 10min reserve) on a new and fully charged battery.

**NOTE:** If you have more batteries, you can charge them outside of the air compressor unit as well.

**!** Only use the original AirBuddy batteries and battery charger.

**!** A damaged battery or charger cannot be used.

**!** The safety link should be disconnected whenever travelling by air and be reconnected upon landing. More information about safe air travel is available in the Air Travel with AirBuddy chapter.

### Step 5: Close the lid

When the battery has been fully charged, the charge indicator turns green. Disconnect the charger and put the lid back on the air compressor unit by pressing it firmly down until the red safety clips engage.



Place the compression handle back on the lid by stretching it over the attachment points on each side of the AirBuddy.



# Before Diving

## INTRODUCTION

Make sure all your equipment is in good condition and the AirBuddy battery has been fully charged before your diving. Visually inspect AirBuddy by checking for any damages such as corrosion, leaks, missing parts, etc. In case of any doubts, please refrain from diving and contact AirBuddy's Customer Service department.

Proper planning and preparation before diving is essential to avoid unexpected problems and prevent possible injuries.

AirBuddy is intended for individual recreational shallow water diving and not commercial diving. It may be used in scenarios such as:

- ✓ Reef diving
- ✓ Underwater photography
- ✓ Underwater boat maintenance and hull cleaning
- ✓ Pool repair
- ✓ Abalone diving, lobstering and spear fishing (where allowed by local jurisdiction)
- ✓ Underwater treasure hunting (metal detection and fossil hunting)

## KEY RULES FOR DIVING WITH AIRBUDDY

1. Do not dive without a proper dive training (at least "open water level").
2. Never dive without a 100% redundant back-up system (egressor or pony bottle).
3. Always inspect AirBuddy and your other gear before diving.
4. Check the weather, wind and sea conditions. Get familiar with the dive site and plan both for your entry and exit.
5. Plan your dive and dive your plan.
6. Assemble the AirBuddy according to this manual. Do not modify the AirBuddy.
7. Never dive with a unit that you suspect is leaking or otherwise damaged and has not passed all pre-dive checks.

8. Never run AirBuddy outside the water. It requires water cooling.
9. Take your time to adjust your weight to achieve neutral buoyancy. Do not dive over-weighted.
10. Follow all diving rules (just like in SCUBA) including, but not limited to:
  - Never holding your breath.
  - Not ascending faster than 18m/min.
  - Monitoring your nitrogen levels by using a diving computer or tables.
  - Never exceeding the NDL (No Decompression Limit).
  - Always making safety stops.
  - Not flying after diving for at least 18/24 hours.
  - Not diving if you are not in good physical condition.
  - Never diving alone or without a supervision by another person, unless you have been trained for solo diving.
  - And other rules as per your diving training.
11. If you no longer remember all of the diving rules, read up or get re-certified.
11. Never use AirBuddy as a personal floatation device.
12. Do not dive in rough seas, rolling waves, strong current or river streams.
13. Never dive in obstructed environments like caves, wrecks and kelp forest. Avoid mooring lines, jetty, boat traffic, etc.
14. Do not use in the proximity of exhaust fumes (e.g. from a boat engine).
15. Do not dive while under the influence of alcohol, medication or drugs.

 If in doubt bail out!

## Gear Preparation

Take your time while setting up the AirBuddy as you could miss some important steps and risk the safety and enjoyment of your diving. Setting up AirBuddy is a simple process, but please make sure you read all the steps in the manual and follow them carefully.

**NOTE:** Always keep the magnetic wristband in the off position (upper slot) while not diving.

### SET UP AIRBUDDY

Place the AirBuddy and all its accessories on a flat and clean surface (or on a towel) to prevent sand from entering the air couplers. Sand can cause an air leak and shorten the life of the air couplers. Make sure you have all the parts and check them for any damage.

**!** Make sure that the battery is fully charged.

#### Step 1: Connect the diver's hose

Connect the diver's hose(s) to the air reservoir. Push the 90-degree air plug at the end of the diver's hose into the air reservoir's air coupler until you hear an audible "click" sound and you can't pull it back.

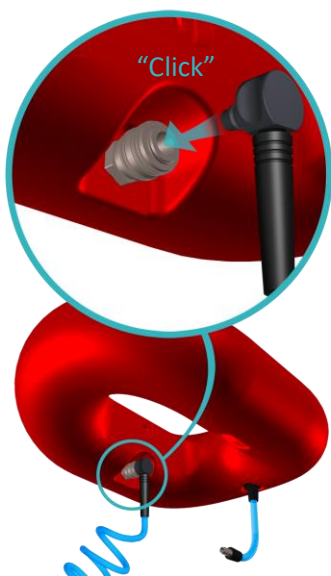

**!** Always make sure that the diver's hose is properly connected to the air reservoir. You must hear a "click" sound and you can't pull the hose back.

**NOTE:** If you are diving with one diver's hose, leave the other coupler unplugged. The air couplers are self-sealing.

**NOTE:** If you dive in buddy set-up (2 divers with 1 AirBuddy), connect the second hose using the same method.

#### Step 2: Insert the compressor unit into the air reservoir

Fit all four hook-and-loop straps through the attachment points on the housing of the air compressor unit. They must face with the fluffy side towards the housing.



Place the AirBuddy's air compressor unit (with the hook-and-loop straps) from the top inside the air reservoir.

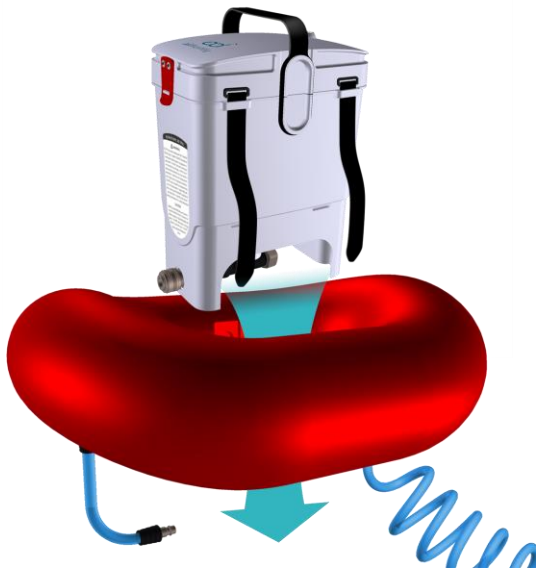

**Step 3:** Connect the air reservoir’s “J” hose

Plug in the “J” hose from air reservoir into the air coupler at the bottom of the air compressor unit.

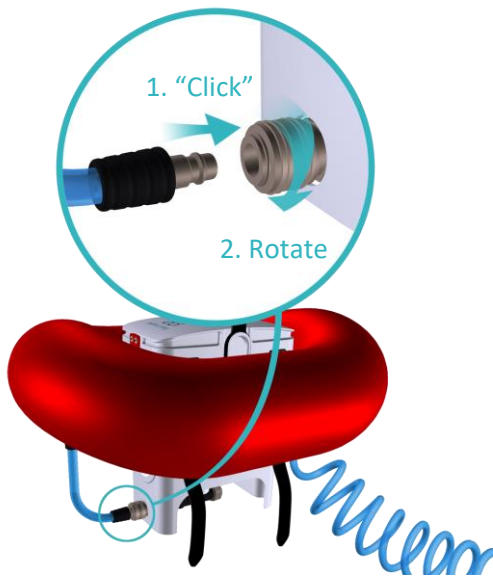

Push the plug into the air coupler until you hear an audible “click” sound and you can’t pull it back. This coupler is fitted with a lock to prevent an accidental release of the hose. Rotate the sleeve of the coupler to misalign the pin with the notch.

**!** Always double check that the coupler of the “J” hose is properly connected to the air compressor unit and you can’t pull it back. Always rotate the sleeve of the coupler to lock the “J” hose. Visually check the coupler to make sure that

the notch (on the coupler sleeve) is on the opposite side than the pin (on the body of the coupler).

**Step 4:** Fasten all four hook-and-loop straps

Thread the loose end of the hook-and-loop strap through the buckle at the other end of it, pull firmly and close by pressing the hook side onto the loop side. Repeat for all four straps.



Lift AirBuddy, turn it upside down and check if the air reservoir is attached properly to the air compressor unit.

**Step 5:** Insert the dive flag

Remove the silicone plug from the lid and push-in the flag post all the way to the bottom. All three red O-rings must disappear in the hole.

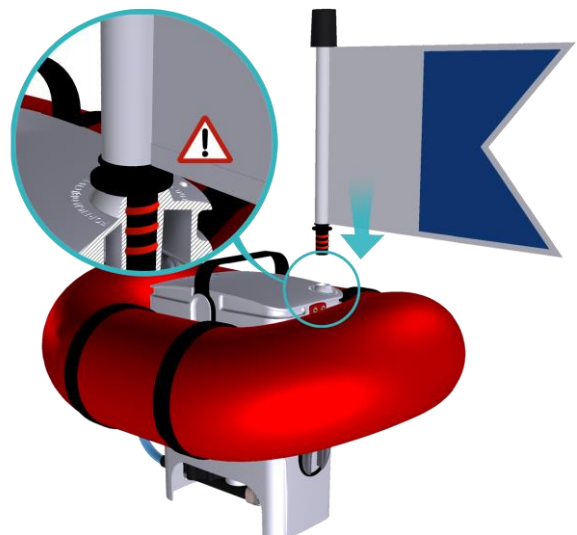



Check for any gaps and make sure that no water can get sucked inside through the lid.

**!** Never dive without the dive flag! AirBuddy draws air from the surface through the flag post. Confirm whether the flag post is clean before use. The dive flag makes you visible to boats, fishermen, etc. and mandates them to keep a safe distance from you.

If you are diving in duo set-up (2 divers with 2 AirBuddies), connect them together with the plastic swivel hook and D-ring. Place them underneath the hook-and-loop straps roughly in the middle of the air reservoir. Clip the two AirBuddies together when launching on the water. This way, both units can float in a formation to prevent hose entanglement.

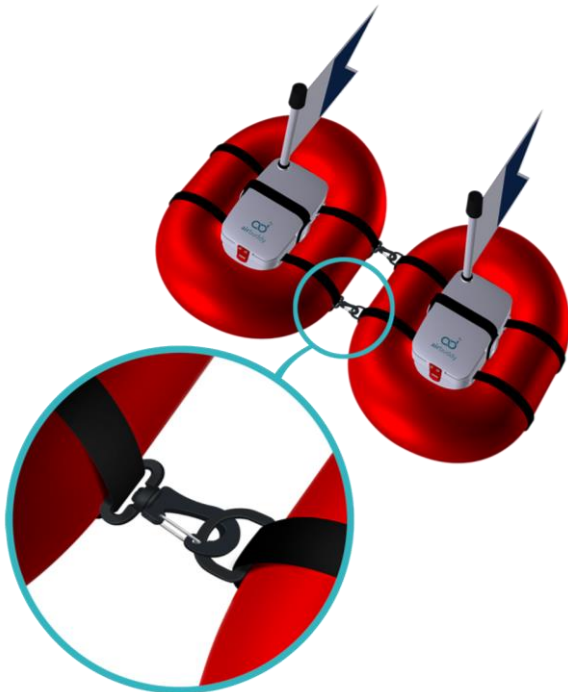

## SET YOUR WEIGHTS

Since you do not use any air cylinder when diving with AirBuddy, you only need to adjust your buoyancy once, at the beginning of your dive with the right amount of weights. You do not use a BCD (Buoyancy Compensator Device), therefore it is essential for your safety and comfort to wear the right amount of weights.

**!** Setting your weights is important, so take your time to make sure you have the right amount of weights to achieve neutral buoyancy.

**!** Always check your buoyancy in shallow water (standing depth) or holding onto a boat, life jacket, inflatable, etc. Start with too little weight and gradually add more weights.

Put on your wetsuit and enter the shallow water with just your weight belt (no AirBuddy) and check your buoyancy. Stop threading water, relax, and you should level up with the water surface at your eye level. You may slightly ascend when breathing in and slightly descend when exhaling. If you are sinking, remove some weights. If you are floating too much, add more weights.

**NOTE:** Your buoyancy depends on several factors, such as the composition of your body (lung size, body fat, etc.), thickness of your wetsuit, water salinity, etc. Therefore, perform buoyancy check every time you go diving and adjust your weights accordingly.

## ATTACH THE HARNESS

**Step 1:** Thread the hose through the red O-ring!

Place the harness on a clean flat surface or a towel. Take the straight end of the diver's hose (the 90-degree end is already connected to the air reservoir) and pull it through the red rubber "O-ring" on the harness (!).

**Step 2:** Connect and lock the air coupler

Push the plug into the air coupler until you hear an audible "click" sound and you can't pull it back. This coupler is also fitted with a lock to prevent an accidental release of the hose. Rotate the sleeve of the coupler to misalign the pin with the notch.

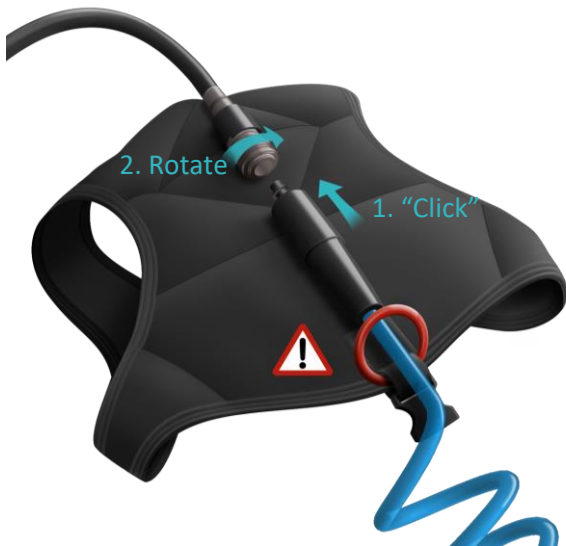

**!** Always check that the diver's hose is properly connected to the air coupler on the harness and you can't pull it back. Always rotate the sleeve of the coupler to lock the diver's hose. Visually check the coupler to make sure that the notch (on the coupler sleeve) is on the opposite side than the pin (on the body of the coupler).

**!** The diver's hose must go through the red O-ring at the bottom of the harness. If you miss this step, you risk that the coupler attachment may get detached from the neoprene vest.

### Step 3: Fasten the buckles

Put the harness on your back and fasten the buckle on your chest. Also fasten the buckle at the back of the harness to the weigh belt strap.



### Step 4: Place the regulator necklace over your head

Place the regulator necklace over your head. The regulator hose should go over your right shoulder.



**!** Before entering the water, make sure that your harness is properly fastened, your hose is locked and your regulator necklace is over your head.

# Getting Ready for Diving

## PRE-DIVE CHECK

 Check all your dive equipment and make sure it is in perfect working condition. Thoroughly inspect AirBuddy for any damage, corrosion, leaks, missing or incorrectly attached parts, etc. In addition to AirBuddy, also check your other dive gear such as your dive computer (watch), egressor, mask, fins, wetsuit, torch, weights, etc.

You can use the below 5-step checklist to ensure all vital functions of the AirBuddy are OK:

V: Visual Check	
<u>Check:</u> - Review all parts individually and look for any damage - Check that no parts are missing	<u>Result:</u> ✓ No damage (cuts, cracks, broken pieces) ✓ No missing part(s)
I: Inspect Air Connections	
<u>Check:</u> - Pull on hoses to check proper connection of (1) diver's hose(s) to the air reservoir, (2) air reservoir's "J" hose to the compressor unit and (3) diver's hose to the regulator - Check that the flag is pushed all the way into the lid	<u>Result:</u> ✓ No disconnection possible if pulling on the hoses ✓ Couplers properly engaged and locked ✓ Flag firmly attached (with no red O-rings visible)
T: Test Run	
<u>Check:</u> - Briefly run the AirBuddy (not more than 10-20 seconds!) - Listen to the sound - Turn the AirBuddy upside down and check that the tilt switch works - Check the pressure gauge for any rapid pressure drop after being turned off	<u>Result:</u> ✓ AirBuddy turns on, pressure increases ✓ Normal "healthy" compressor sound (no rattle or seepage) ✓ Turning AirBuddy upside down stops the compressor and starts the siren, AirBuddy re-starts few seconds after put back upright ✓ No rapid pressure drop after being turned off

A: Air Flow Check	
<u>Check:</u> - Press the purge button of the regulator - Smell the air by nose	<u>Result:</u> ✓ Air is released through the regulator ✓ No odour
L: Look Again	
<u>Check:</u> - Look again at the entire assembly and check whether any parts are loose - Try to spot anything unusual	<u>Result:</u> ✓ No parts are left in your bag ✓ All parts are firmly attached ✓ Hook-and-loop straps are tight ✓ Nothing unusual

 Do not use AirBuddy if it fails any of the pre-dive checks or shows any other signs of malfunction or damage.

 Make sure that the battery screws are firmly tightened to provide a good connection between the battery terminals and the AirBuddy wires. Check and fasten the battery wires before each dive. Proper connection of the battery wires is crucial to prevent increased electrical resistance that could lead to a potential risk of battery terminal overheating.

 Wear a 100% redundant air system, such as an egressor or pony bottle (e.g. Spare Air). Make sure it has been maintained as per the manufacturer's instructions and that it is full!

## DIVE PREPARATION

 Get familiar with the dive site. Ask locals about the currents, tides, key underwater features, marine life, potential hazards, etc. Check the weather forecast for wind speed and swell. Plan your entry and exit points. Inform someone on the surface about your intended dive plan and expected return time and what to do/ whom to contact if you went missing.

 Make sure that the AirBuddy battery is fully charged (indicator light on the charger turns green).

**NOTE:** If you are diving in buddy set-up (2 divers with 1 AirBuddy), decide who amongst you will be the “dive leader”, i.e. the person responsible for choosing the direction and pace of the dive. The dive leader will also hold the magnetic wristband and ensure that AirBuddy will be turned off only after both divers have safely returned to the surface.

## ENTERING THE WATER

If you enter the water from a shore, avoid any rolling waves, surf or wash to prevent the risk of capsizing the unit. Support AirBuddy by hand until you reach an area with calm surface.

If you enter the water from a boat, do not jump-in with AirBuddy in your hand or throw it in the water. You could capsize the unit. Gently launch AirBuddy on the surface. Then, carefully slide in the water. “Giant stride” or “back roll” entry is not recommended and potentially hazardous.

**!** Never dive in dangerous dive conditions such as rolling waves or surf. AirBuddy could capsize, i.e. stop the air in-flow and water ingress could damage the product.

### Step 1: Launch AirBuddy on the surface

Gently place AirBuddy on the water and check if it floats OK on the surface.

**!** Make sure there are no obstacles that could restrain free movement of the AirBuddy on the surface, such as mooring lines, jetty, etc. Avoid diving in proximity to falling rocks or kelp forests. Never use AirBuddy for penetrating wrecks or caves!

**!** Do not use AirBuddy for personal floatation. It has been designed to only support its own weight. If you need, attach a floating device (e.g. inflatable ring) to AirBuddy and hold onto it.

### Step 2: Turn AirBuddy on

Take off the magnetic wristband from AirBuddy. It will start pressurising and you will hear the compressor running. The air is now flowing from the compressor into the air reservoir. The air reservoir provides air balancing and emergency air reserve.

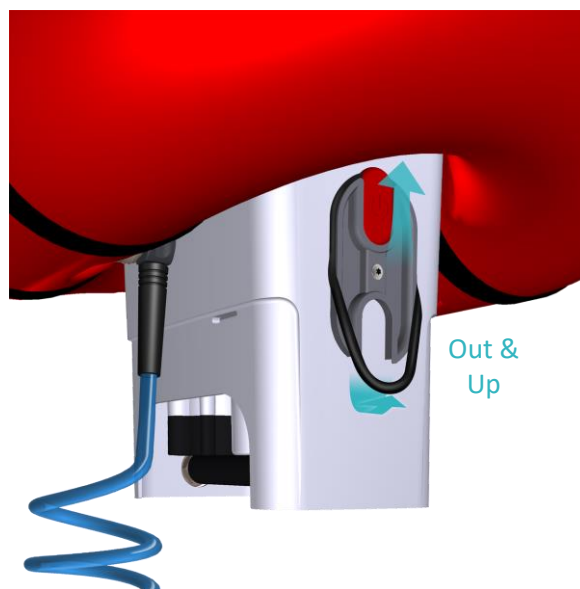

Wait for about 40 seconds until the system fully pressurises. Look underwater and check the pressure gauge that the pressure has reached about 2.6 bar (38 psi). This is the maximum system pressure. Excess pressure is released through an internal over-pressure valve.

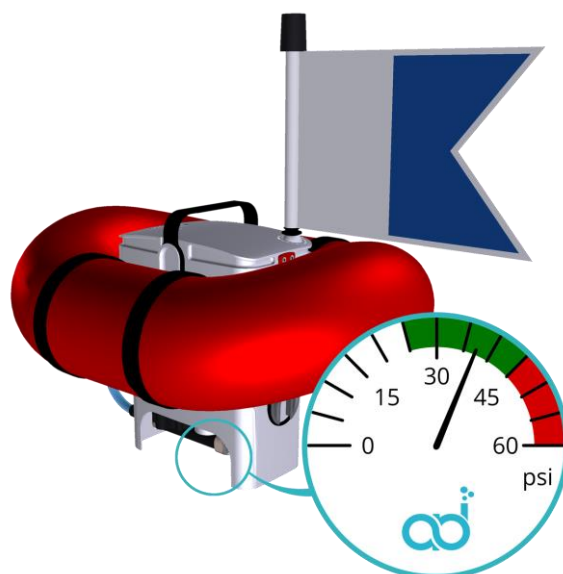

**!** If you don't hear the compressor running, the system pressure is too low or too high (i.e. outside of the green area on the dial of the pressure gauge), interrupt your dive immediately and return to the surface. Release any pressure from the system by pressing the purge button on the regulator and read the chapter Troubleshooting.

Put the magnetic wristband on your wrist.



**NOTE:** If you cannot wear the magnetic wristband on your wrist, you may turn it by 180 degrees and place it into the lower slot of the attachment on the compressor unit. The compressor will run with the magnetic wristband in this position.

**!** Strong magnet! Keep the magnetic wristband away from your dive computer or compass. Wear it on your other hand.

**!** Do not operate AirBuddy outside of water. It must float on the surface because the air compressor requires water cooling!

**!** Never use AirBuddy in an area with heavy boat traffic. Boat collision could be fatal!

**!** Do not use AirBuddy in the proximity of exhaust fumes (e.g. from a boat engine).

### Step 3: Put the regulator in your mouth

Place the regulator in your mouth and take a few test breaths before you dive underwater.



### Step 4: Descend

Descend slowly. Equalise your ears all the time while descending. If you feel any discomfort, stop descending and return to the surface.

**!** Always keep the regulator in your mouth while diving.

Look at AirBuddy underwater and check for any air bubbles that would indicate an air leak. Inspect the air reservoir, the compressor unit and the hose. If you spot any air leaks, stop diving and safely return to the surface. Read the chapter Troubleshooting.

# Diving Instructions

## BREATHING UNDERWATER

Breathing underwater with AirBuddy should be effortless if you breathe naturally. Relax and slowly breathe in and out. Do not forcibly draw the air as this will not increase the airflow. Do not bite the regulator's mouthpiece hard. It is not necessary. It would just increase the jaw fatigue.

Should you feel that the air flow is insufficient, relax, slow down, and change your breathing pattern to long deep breaths. If the breathing discomfort continues, ascend to a shallower depth. You may be too deep. If the issue still persists, you may have missed the low battery warning (the battery is getting flat) or there could be an air leak in the system. End your dive immediately and safely return to the surface.

 Follow all the dive instructions as per your dive training and this manual at all times.

 Never hold your breath when diving! You risk experiencing pulmonary barotrauma (lung overexpansion)!

 Do not continue diving if breathing feels restricted or uncomfortable. Ascend. Should the air supply stop, use an egressor/ pony bottle or perform CESA (Controlled Emergency Swimming Ascent) to return to the surface.

 Look up from time to time to check if AirBuddy and the hose are clear of obstacles and entanglement.

**NOTE:** If you are diving in pairs (either in buddy set-up or duo set-up), make sure that both divers swim in similar depth for safety reasons and comfort.

**NOTE:** In addition to the sound of your breathing, you hear the sound of the AirBuddy compressor underwater. It does not disturb the underwater wildlife. It does however assure you that AirBuddy operates.

## DIVE DEPTH AND DIVE TIME

Frequently check your dive time and depth on your dive computer (watch). Your dive should never exceed 55 minutes and you should never dive deeper than 12m (40 ft) for one diver and 6m (20 ft) for two divers. The air flow could be insufficient, and you risk capsizing AirBuddy.

AirBuddy will run for approximately 55 minutes (plus about 10 minutes reserve time) on a full battery. A low battery warning signal is triggered when the battery voltage level drops below certain threshold. There is a continuous runtime expiry siren (sweep tone). This is the signal for you to ascend. Should you miss the siren, ascend no later than after 55 minutes from the start of AirBuddy.

**NOTE:** The siren may start earlier than 55 min if the batteries are cold or aged, there is a poor electrical connection (leading to electrical resistance and voltage drop) or there is a mechanical issue that leads to an increased current draw.

 Do not cover your ears while diving (e.g. wearing a wetsuit hood or headphones). This could decrease your hearing ability and you may miss the warning signal.

 Never exceed the maximum diving time and depth.

 Never ascend faster than the maximum ascent rate of 18m/min (60 ft/min) recommended by PADI or as per your dive training. Risk of decompression sickness (aka "bends").

**NOTE:** Different dive associations recommend different maximum ascent rates.

 Make a safety stop, especially if you are diving deeper than 10m (33 ft).

 Should the airflow gradually reduce, your battery is getting low. End your dive and safely return to the surface.

**NOTE:** When the battery depletes, AirBuddy stops functioning (there will be no buzzing sound of the

compressor anymore). Despite the air reservoir holds almost 16 litres of air, this should only be used in an emergency situations!

**!** Never run the battery completely flat. Allow some sufficient reserve time for any unexpected situation.

## COMPLETING YOUR DIVE

When you finish diving, place the magnetic wristband back to the upper slot of the attachment on the compressor unit to turn AirBuddy off.

**!** If you are diving in a buddy set-up, turn AirBuddy off only after both divers are safely on the surface.

**!** Always keep AirBuddy off while not diving.

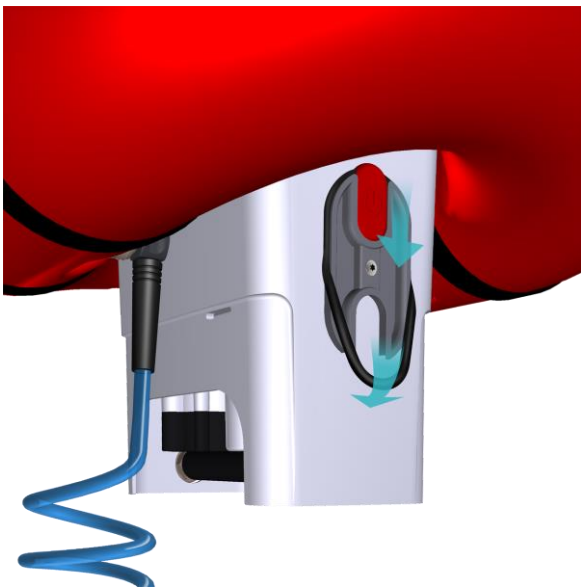

Lifting AirBuddy by the handle and carry it back to the beach or place back on the boat deck. Dry AirBuddy firmly. If you would like to swap the battery and go for a second dive, thoroughly dry the unit before opening the lid. (see the instructions in the chapter “Multiple Dives” on how to swap the batteries).

**!** Never lift AirBuddy by the hose.

## Consecutive Dives

If you purchased one or more additional batteries, you can swap the battery and go for another dive.

 Only use the original AirBuddy batteries and charger. Make sure your replacement battery is fully charged before diving.

### REPLACING BATTERIES

#### Step 1: Remove the air reservoir

Loosen the hook-and-loop straps. Remove (or just lower) the air reservoir.

#### Step 2: Open the lid

Remove the compression handle and gently lift the red clips on each side of the lid. Carefully open the lid. (see instructions in chapter Initial Assembly).

#### Step 3: Swap the battery

Unscrew the stainless-steel button-head screws on the side of the battery using the hex key and disconnect the battery wires from the battery terminals. Remove the discharged battery.

Place the new battery inside of AirBuddy with the battery terminals facing the battery wires. Connect the wires and firmly tighten the two screws using the hex key.

 Always firmly tighten the battery screws (about 3-4 Nm) to provide a good connection between the battery terminals and the AirBuddy wires. Check and fasten the battery wires before each dive.

 High electrical current passes from the battery to the compressor of AirBuddy through the battery wires. Proper connection of the battery wires is crucial to prevent increased

electrical resistance that could lead to a potential risk of battery terminal overheating.

 Always care about the battery terminals and lugs. Prevent any contact with water (leading to oxidation), mechanical damage (e.g. scratches) or dirt (e.g. grease residues) that could impede the electrical conductivity of the connection.

#### Step 4: Close the lid

Put the lid back on AirBuddy and press firmly down until the safety side clips engage. Place the compression handle back. Install the air reservoir.

#### Step 5: Charge the depleted battery

Plug the power lead in the power source and then plug the battery charger into the battery charging connector.

**NOTE:** AirBuddy battery's standard charger works with the AC power (100-240V, 50-60 Hz). You can optionally purchase a 12 VDC charger to charge the battery on your boat or a car.

Battery charging takes approximately 5.0 ~ 5.5 hours. The led indicator on the charger will turn from red to green as soon as battery is fully charged.

**NOTE:** You can charge the battery outside or inside of the air compressor unit. AirBuddy must be off when charging!

**NOTE:** Always fully charge the battery.

**NOTE:** If you wish to order additional battery(s), please contact AirBuddy customer representative or a dealer.



## After Diving

### Step 1: Release the air

Take AirBuddy out of water, put it on a flat, clean surface and press the purge button on the regulator to release all air from the system.



⚠ Never lift AirBuddy by the hose.

### Step 2: Disconnect the diver's hose

To disconnect the hose from the harness, rotate the sleeve of the coupler to align the pin with the notch, push the sleeve in and pull out the hose.

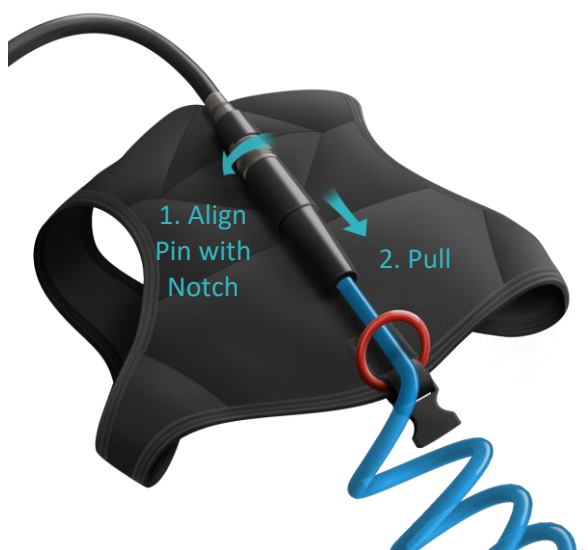

### Step 3: Detach the dive flag

Remove the flag and insert the 'Lid Plug' back into the hole on the lid.

⚠ Always plug the lid hole when not diving, especially when you rinse, transport or store AirBuddy.

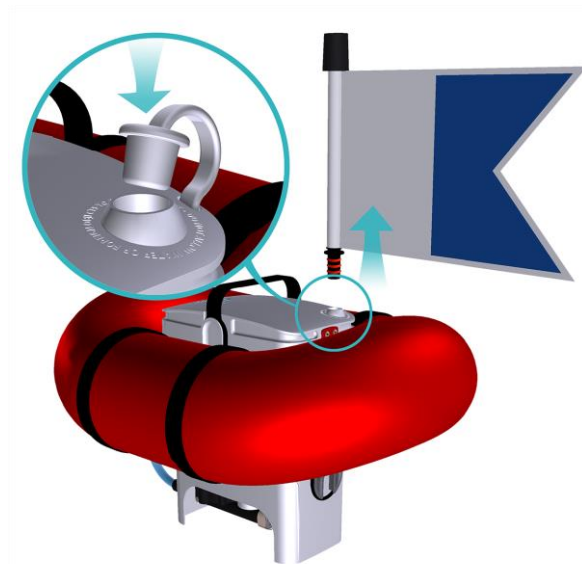

### Step 4: Disconnect the air reservoir's "J" hose and remove all four hook-and-loop straps

To disconnect the air reservoir's "J" hose from the compressor unit, rotate the sleeve of the coupler to align the pin with the notch, push the sleeve in and pull out the hose.



**Step 5: Take out the compressor unit**

Hold the handle and lift the compressor unit up.

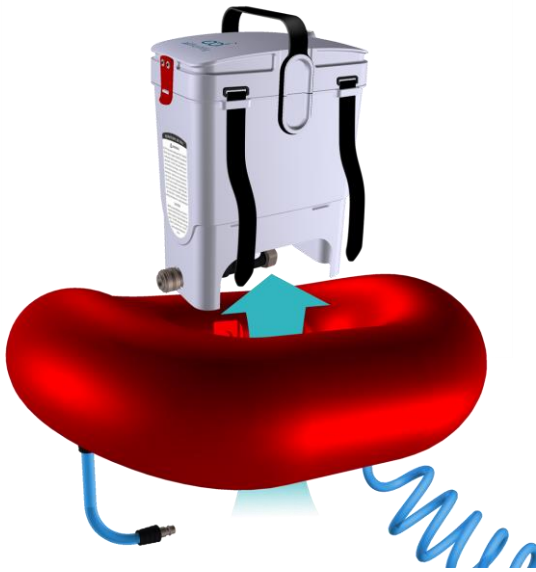

**Step 6: Disconnect the diver's hose**

To disconnect the diver's hose from the air reservoir, push the coupler's sleeve in until the hose is released. Pull out the hose.

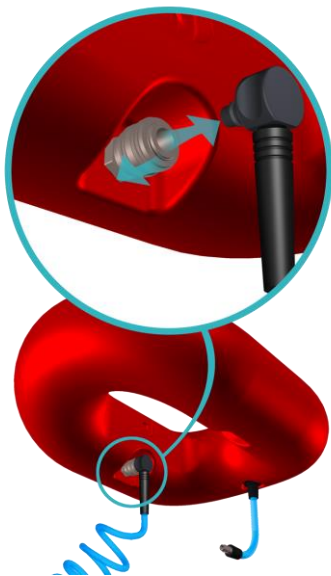

**Step 7: Rinse AirBuddy in fresh water**

Rinse the AirBuddy parts in the fresh water to remove any salt residues or sand.

**!** Do not rinse with any of the hoses (float's "J" hose or the diver's hose) attached to the air couplers. Make sure that the coupler's internal mechanism is thoroughly rinsed of sea water to prevent oxidation and limescale build up that could freeze the parts in place during storage.

**!** Always cover the air plugs (on both end of the diver's hose and the air reservoir's "J" hose) with plastic caps when washing. Make sure no water or debris enters the hoses.

**NOTE:** If you use AirBuddy extensively and in high-humidity air, a small amount of condensation water can build up inside the air reservoir. If so, follow the instruction in the section Maintenance and Periodic Inspection to remove the water.

**!** Rinse AirBuddy regulator in fresh water only. Do not use any soap!

**Step 8: Charge battery & store**

Dry AirBuddy (out of direct sunlight). Open the lid and check if there is no water inside the system. Recharge the battery as soon as possible after use and store it charged. Recharge the battery at least every 6 months if not used.

## Air Travel with AirBuddy

AirBuddy has been designed with portability and stowability in mind. AirBuddy is the world's smallest and lightest dive equipment, which makes it a perfect companion on your travels.

### AIR TRAVEL REGULATIONS

Air travel with lithium battery(ies) is subject to Dangerous Goods Regulation (DGR) by IATA, in conjunction with other regulations from international or national bodies such as ICAO, UN, FAA, CASA, etc. AirBuddy has been designed to comply with the 59<sup>th</sup> version of the IATA DGR.

Please note that the DGR is subject to changes from time to time and that some airlines may decide to adopt different or additional rules.

AirBuddy battery is a lithium iron phosphate (LiFePO<sub>4</sub>) battery duo-pack, with 2 batteries of 156 Wh (26Ah, 6V) each, in a single housing, protected by an internal BMS (Battery Management System).

Current DGR allows air travel with up to two spare batteries between 100 and 160 Wh (i.e. one AirBuddy battery duo-pack) per person aboard a passenger airplane upon an approval of the airline staff and subject to specific transport conditions.

### HOW TO PREPARE FOR AIR TRAVEL

 Always check the Dangerous Goods guidelines of your airline and/or consult with the airline staff before travel with AirBuddy.

 Always declare the AirBuddy battery(ies) at check-in and follow the instructions from the airline staff. Inform the staff at the security check.

**NOTE:** It is a good idea to print the latest IATA guide for travelling with lithium batteries before you travel to prevent confusion at the airport.

1. Remove the battery from the device.
2. Remove the Safety Link from the battery to disconnect the 2 internal batteries contained in one battery duo-pack.
3. Protect the exposed battery terminals to prevent short circuit by placing the battery in the neoprene travel case (or otherwise insulate the exposed terminals, by e.g. a tape or placing the battery in a plastic bag).
4. Transport the battery(ies) in carry-on luggage.



 Always remove the Safety Link before flight. Reconnect the Safety Link immediately after landing, i.e. remove the Safety Link for the shortest required time.

## Maintenance and Periodic Inspection

AirBuddy has a simple, but robust design. It will last for a long time if you look after it properly – do not abuse, rinse in fresh water, store in a dry place without direct sunlight, keep the battery recharged, etc.

Inspect your AirBuddy before and after each dive. Check for any damage, corrosion or material degradation.

Many AirBuddy parts can be easily replaced by the user without any tools, while some others require a little technical knowledge and the use of few standard tools.

### STORAGE TIPS

Always keep your AirBuddy and all parts including battery in the dry location and make sure that the unit is out of reach of direct sunlight, dirt and dust.

Rinse AirBuddy in fresh water after each dive(s). Do not use soap. Store your AirBuddy in a dry place without direct sunlight. Keep the battery recharged.

If you don't use AirBuddy regularly, run your AirBuddy every few months to check operation – run AirBuddy in the water (you can use sink or bath), because AirBuddy compressor needs water for cooling.

**NOTE:** You may also briefly run AirBuddy outside of water, but only for a maximum of 10-20 seconds and provided that the compressor is cool (at room temperature) at the start.

### BATTERY

The AirBuddy battery is maintenance-free with proper charging and storage. Keep the battery always charged and store it outside of air compressor, in clean and dry place.

 Always remove and recharge the battery immediately after use. Store it fully charged.

Batteries do self-discharge and the charge could drop low enough to cause damage to the battery. Recharge the battery every 6 months if not used.

 Do not expose to temperature above 60° C. High temperature may cause premature battery failure.

**NOTE:** AirBuddy battery uses LiFePO4 chemistry and was designed to retain more than 80% of its capacity after 1,500 cycles (full charge & full discharge) in optimal conditions.

 Always use only original AirBuddy charger. The battery's standard charger works with the AC power (100-240 V), but you can also purchase AirBuddy 12 VDC outlet charger to charge the battery from your boat or car.

### HOSE & COUPLERS

Look after your hose with care. Do not kink it, keep away of direct sunlight and sharp objects. Do not use soap or any chemicals to clean it. Always plug the hose ends with plastic caps when rinsing in fresh water.

 Do not store with the any of the hoses (float's "J" hose or the diver's hose) attached to the air couplers to prevent oxidation and limescale build up that could freeze the parts in place.

 Always inspect the hose before each dive to make sure that it doesn't have any cracks or leaks. Check for any (even small) leaks in water.

The air couplers are fitted with a safety lock to prevent accidental disconnection. Make sure that the air couplers are free from any sand or debris. Rinse them thoroughly in fresh water after each diving.

 If you have difficulties to connect and lock an air coupler, it may be blocked by sand or there may be a damage. Stop using your AirBuddy and contact the customer support.

## AIR RESERVOIR

Please look after your air reservoir carefully. Keep it away from any sharp objects that could puncture the wall. Do not crush it. Be careful not to damage the "J" hose swivel connection.

Keep the air reservoir in a dry and clean location, out of direct sunlight.

**!** Always check the air reservoir before each dive, look for any damage and possible air leaks.

**!** Always release residual air after each dive from the air reservoir before uncoupling the hoses. Never store AirBuddy with residual pressure in the air reservoir.

## HOW TO REMOVE CONDENSATION WATER FROM THE AIR RESERVOIR

Some condensation water may build up inside the air reservoir if you dive in humid areas or more frequently.

You can easily remove the water with the "condensation water removal tube" that we shipped with your AirBuddy. Thread it through the "J" hose on the float to reach the bottom of the float. Place the float upside-down so that the water is at the lowest point.



Connect the 90-degree plug of the diver's hose directly into the compressor unit. Plug the other end of the diver's hose in one of the couplers on the air reservoir. Run AirBuddy to push the water out.

**!** Do not run the compressor for longer than 10 seconds without water cooling. You may damage your AirBuddy if you run it outside of water for longer.

**NOTE:** Please note the orientation of the hose on the picture (it contains a non-return valve and therefore it only allows air to flow in one direction).

## COMPRESSOR UNIT

The compressor unit must be closed for washing, transportation or storage. Remove the dive flag and always plug the lid hole with the silicone plug. Make sure that the lid of the compressor unit is always properly closed with the safety side clips and the compression handle in place!

Rinse or shower the compressor unit in fresh water after each dive.

**!** Do not submerge the lid seal underwater for longer than few seconds when washing. Do not open AirBuddy compressor lid underwater or wash the inside of the compressor unit!

Store in dry, clean place without direct sunlight.

## OTHER PARTS

Look after all parts with reasonable care and make sure that all parts are stored dry and clean if AirBuddy is not in use.

Regular inspection of all your dive gear is crucial for your safety. Check for any damage, corrosion or deterioration before any diving.

**NOTE:** If you suspect that some AirBuddy's parts are not working properly, have any damages or signs of degradation, please do not use AirBuddy and contact our customer service representative. For contact details, please visit [www.airbuddy.com](http://www.airbuddy.com).

## WHAT TO DO IF AIRBUDDY CAPSIZED

Please follow these steps if you accidentally capsize or submerge your AirBuddy:

1. Immediately stop diving and turn off the AirBuddy.
2. Get the AirBuddy unit ashore and place it on clean and flat surface.
3. Open the air compressor unit's lid and remove the battery.
4. Inspect the interior of the AirBuddy for any traces of water.
5. If no water has reached the interior of the AirBuddy or there is just a small amount of water contained in the water trap (but not anywhere else!), remove the silicone grommet, dry inside and re-assemble.

6. If water has spilled into the internal components of AirBuddy, i.e. overfilled the water trap and travelled inside the compressor, refrain from using AirBuddy and book a service inspection. The compressor may need to be overhauled or replaced.

 If AirBuddy doesn't function properly or doesn't produce sufficient air pressure or flow, desist from diving and contact AirBuddy's customer service representative.

 If you accidentally flood the battery by dropping it in the water or make it substantially wet by any other way (e.g. leave outside in the rain), it should not be used again! Dispose of such battery at a recycling station.

Please take note of the recommended inspection intervals. Regular inspection of your dive equipment is essential to prevent unexpected failures or malfunctions, thus ensuring safe operation and increasing the machine's lifespan.

INSPECTION	CYCLE					MAINTENANCE
	Before Each Dive	Every 10 Dives	Every 100 Dives	Every 6 Months	Every 1 Year	
General Pre-Dive Inspection	X					Inspect AirBuddy for any damage, leaks, corrosion, material degradation, missing parts, water inside, etc. Tighten all battery terminals. If you find any issues, contact our customer service or your dealer for advice, spare parts or service.
Air Reservoir		X				Check the air reservoir for presence of any mould or bacteria (hold against light/ smell). If required, remove the "J" hose and pour inside about 1 litre solution of warm water (30-40 °C) with water bottle cleaning tablet(s) or denture cleaning tablet(s). Shake it vigorously and let it sit for few hours. Rinse thoroughly with fresh water. Remove all water and re-install the "J" hose. Make sure the connection is air tight and there is no leak.
Hose Filters		X				AirBuddy hose is fitted with 2 lifetime (dust) filters. Check that the filters didn't clog-up by (1) attaching the 90-degree plug at one end of the diver's hose to the air coupler on air compressor unit, (2) leaving the other hose end free and (3) briefly running AirBuddy (no more than 10-20 sec!). Monitor the pressure gauge during the test. It should remain at "0 psi".
Hook and Loop Straps		X				Check the hook and loop straps for any tears or decrease of adhesion strength. Replace with new ones if they deteriorate below 70% of their original condition.
Air Compressor			X			Book a service with us or an authorised technician to overhaul the AirBuddy compressor (replacing the piston, cylinder and valve), replace seals, lubricate, re-adjust and test your AirBuddy.
Battery				X		The battery will slowly self-discharge if not used. Recharge the battery at least every 6 months.
Regulator					X	Get your regulator inspected/ serviced and thoroughly cleaned in any dive shop by a professional technician (just like with your SCUBA regulator).

 Never alter, add, remove or reshape any functional item of AirBuddy.

 Do not use any non-original spare parts or substitute any AirBuddy parts with third party items.

 AirBuddy air compressor must be rebuilt (replacing the piston, cylinder and valve) every 100 dives.

 AirBuddy regulator must be inspected at least once per year by a professional service technician in any dive shop.

# Troubleshooting

Repairs and maintenance work on AirBuddy that go beyond the procedures described in this chapter may only be carried out by an authorised technician.

MALFUNCTION	PROBABLE CAUSE	SOLUTION
AirBuddy does not run	<ul style="list-style-type: none"> <li>• AirBuddy is not in upright position</li> <li>• Battery is not charged</li> <li>• Battery is not properly installed</li> </ul>	<ul style="list-style-type: none"> <li>✓ Place AirBuddy upright.</li> <li>✓ Recharge the battery.</li> <li>✓ Install the battery as per the chapter Initial Assembly.</li> </ul>
AirBuddy runs, but no air flows	<ul style="list-style-type: none"> <li>• Regulator stuck</li> <li>• Faulty compressor or pressure relief valve</li> <li>• Major air leak</li> </ul>	<ul style="list-style-type: none"> <li>✓ Book inspection and repair/ replacement of the faulty parts by authorised service technician.</li> </ul>
Air leak	<ul style="list-style-type: none"> <li>• Couplers are not properly engaged</li> </ul>	<ul style="list-style-type: none"> <li>✓ Check if all couplers are properly connected.</li> </ul>
Insufficient air supply	<ul style="list-style-type: none"> <li>• Air leak</li> <li>• Air hose blocked</li> <li>• System not pressurised</li> <li>• Diving too deep</li> </ul>	<ul style="list-style-type: none"> <li>✓ Check if all couplers are properly connected.</li> <li>✓ Check if there is air bubbles coming out from some part of AirBuddy.</li> <li>✓ Inspect the diver hose and if required, replace.</li> <li>✓ Wait at the beginning to pressurise AirBuddy to at least 30psi (check pressure gauge underwater) and only then start breathing.</li> <li>✓ Ascend to shallower water.</li> </ul>
Strange noise or erratic behaviour	<ul style="list-style-type: none"> <li>• Water intrusion</li> <li>• Faulty compressor</li> </ul>	<ul style="list-style-type: none"> <li>✓ Check if there is no water in the unit. If yes, book repair/ replacement by authorised service technician.</li> </ul>
Battery is not charging	<ul style="list-style-type: none"> <li>• Charger is not properly plugged in</li> </ul>	<ul style="list-style-type: none"> <li>✓ Check if charger connector is plugged in properly into the battery and wall socket.</li> <li>✓ Use different wall socket(s).</li> </ul>
Low battery siren starts too early	<ul style="list-style-type: none"> <li>• Poor electrical connection (increased resistance and voltage drop)</li> <li>• Batteries are cold or aged</li> <li>• Mechanical issue (increased current draw)</li> </ul>	<ul style="list-style-type: none"> <li>✓ Clean all 4 battery terminals. Tighten both battery Safety Link and the wires.</li> <li>✓ Replace battery.</li> <li>✓ Book service by authorised service technician.</li> </ul>

For service or repairs, please contact OXY Pty Ltd by e-mail at [info@airbuddy.com](mailto:info@airbuddy.com) or your specialist dealer. A specialist will assist you in identifying the cause of the error and take further action if necessary.

Please have the following information ready:

- Model name
- Serial number
- Your contact details
- Exact description of the malfunction or damage



# Consumer Information

## CONTACT

Our team strives to provide you with a high level of support. We value our customers and aim to continuously improve our products and your customer experience. Please do not hesitate to contact us at [info@airbuddy.com](mailto:info@airbuddy.com) if you have any questions, suggestions or ideas. Thank you!

Our customer representatives will require the model number and serial number of your device in order to provide you with correct advice. You can find these numbers on the label located outside AirBuddy or underneath the battery. Example:

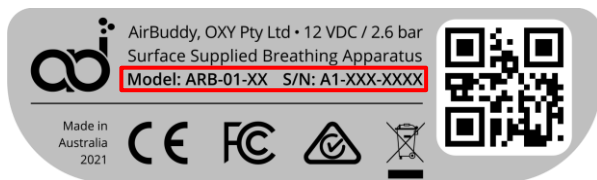

AirBuddy is manufactured in Australia by OXY Pty Ltd.

## RECYCLING AIRBUDDY

We care about environment protection and hope you, too.

AirBuddy's components contain valuable materials that can be recycled. Please recycle AirBuddy in accordance with the instructions from your national recycling scheme.



Please dispose off AirBuddy properly. Materials contained in the components such as batteries, if handled or disposed of incorrectly, can pose a potential threat to human health and natural environment.

 Never throw AirBuddy or AirBuddy's battery into household rubbish!

## AUSTRALIA RECYCLING INFORMATION

Please always dispose of AirBuddy in accordance with the local environmental regulations. You might contact your local council for advice or alternatively, search for an appropriate collection point, e.g. here: [www.recyclingnearyou.com.au](http://www.recyclingnearyou.com.au)

## NEW ZEALAND RECYCLING INFORMATION

Please always dispose of AirBuddy in accordance with local environmental regulations. You might contact your local council for advice or alternatively, search for an appropriate collection point, e.g. here: [www.e-cycle.co.nz](http://www.e-cycle.co.nz)

## UNITED STATES OF AMERICA RECYCLING INFORMATION

Please always dispose of AirBuddy in accordance with local environmental regulations. You might contact your local council for advice or alternatively, search for an appropriate collection point, e.g. here: <https://search.earth911.com>

## EUROPEAN UNION RECYCLING INFORMATION

If you are located in European Union, please contact AirBuddy customer service representative, who will advise a postal address where you can return your old AirBuddy for recycling.

Alternatively, you can contact your local authorities for an advice or search internet for a nearest collection point of electronic waste.

## OTHER COUNTRIES

Please always dispose of AirBuddy in accordance with local environmental regulations. You might contact your local council for an advice or alternatively, search for an appropriate collection point.

# Warranty Policy

## LIMITED WARRANTY

OXY Pty Ltd warrants, to the original purchaser only, that the AirBuddy product(s) purchased will be free of defects in materials and/or craftsmanship for a Warranty Period of one year\* from the date of purchase (delivery date for online orders) under normal use and with proper maintenance as prescribed by AirBuddy's published product materials, including, but not limited to, user manuals, safety instructions, specifications and service communications.

Depending on the country, particular and variable warranties may apply in relation to applicable legislation. Nothing in this Warranty Policy can exclude or limit these statutory provisions.

To the extent permitted by national laws, the Warranty Period will not be extended, renewed or otherwise affected due to subsequent resale, repair or replacement of the product. However, part(s) replaced during the Warranty Period will be warranted for a new Warranty Period of one year<sup>1</sup>, provided such replacement has been performed by AirBuddy representative.

Your rights, as purchaser, against OXY Pty Ltd under this Warranty are limited to the repair and replacement of any defective components. OXY Pty Ltd's maximum liability under this Warranty will not exceed the original purchase price of the defective unit, and OXY Pty Ltd reserves the right at its sole discretion, to refund the purchase price in lieu of repair or replacement.

Shipping charges relating to warranty claims are at the expense of the purchaser unless otherwise agreed in writing with OXY Pty Ltd.

By using your AirBuddy product(s), you agree to be bound by this Warranty Policy. If you are not eligible or do not agree to any of the Terms, do not use your AirBuddy product(s).

## CONDITIONS AND RESTRICTIONS

This Limited Warranty does not cover:

- Normal wear and tear of the Product.
- Damage from accident, abuse, neglect and/or tampering.
- Damage caused by lack of proper care and maintenance and/or improper periodic servicing.
- Damage caused by an inappropriate mounting or assembly of the Product.
- Damage caused by reliability or compatibility issues when using unauthorized third-party parts.
- Damage caused by any third-party products.
- Damage caused by unauthorized modifications and repair.
- Damage caused by diving that did not follow instruction manual recommendations.
- Damage caused by operation in bad weather (e.g. storms, strong currents, rolling waves, etc.).
- Damage (incl. corrosion) caused by ingress of water.
- Damage caused by mismatch or misuse of the battery and charger.
- Damage caused by operating the unit with a low-charged or defective battery.
- Damage caused by the transportation, handling or storage of the Product.
- Damage caused by a forced diving when components have aged or been damaged.

---

<sup>1</sup>Warranty period may vary according to local laws and regulations.

This Limited Warranty is not enforceable if:

- The Product serial number has been removed, deleted, altered or made illegible.
- The Product has been modified or repaired by any person or entity other than AirBuddy representative.
- The Product has been repaired with unauthorized spare parts.

## WARRANTY ENFORCEMENT

AirBuddy or its authorized retailer shall at its sole discretion either (a) repair the Product or (b) replace the Product at no charge (excluding shipping and handling charges). The appropriate remedy will be determined by AirBuddy based upon the following considerations:

- (a) the value of the Product with no Defect,
- (b) the significance of the Defect,
- (c) the inconvenience each remedy would place on the original purchaser.

## HOW TO OBTAIN WARRANTY SERVICE

If a product does not function as warranted during the warranty period, please check the troubleshooting section of the user manual. If this does not help, please contact AirBuddy's service centre via service contact details, which are available on [www.airbuddy.com](http://www.airbuddy.com). You will need to provide a valid proof-of-purchase, receipt or order number for the warranty service.

AirBuddy will attempt to diagnose and resolve your problem by telephone, e-mail or online chat. If your problem cannot be resolved, you may be required to deliver the product to AirBuddy for further examination. AirBuddy will arrange for repair or replacement service at no cost (excluding shipping and handling charges) if the problem falls under this Limited Warranty.

Charges may apply for services not covered by this Limited Warranty. Please contact AirBuddy for information specific to your location. The warranty service is only available in the respective regions where you purchased your AirBuddy product.

## DISCLAIMER AND LIMITATION OF LIABILITY

WHEN RECEIVING SERVICE, AIRBUDDY IS RESPONSIBLE FOR LOSS OR DAMAGE TO YOUR PRODUCT ONLY WHILE IT IS IN AIRBUDDY'S POSSESSION, NOT IN TRANSIT.

TO THE MAXIMUM EXTENT PERMITTED BY LAW, THIS LIMITED WARRANTY IS YOUR SOLE AND EXCLUSIVE REMEDY AND IS IN LIEU OF ALL OTHER WARRANTIES, EXPRESSED OR IMPLIED. OXY PTY LTD SHALL NOT BE LIABLE FOR SPECIAL, INCIDENTAL, PUNITIVE OR CONSEQUENTIAL DAMAGES, INCLUDING BUT NOT LIMITED TO LOSS OF ANTICIPATED BENEFITS, LOSS OF USE, LOSS OF REVENUE, COST OF ANY SUBSTITUTE EQUIPMENT OR FACILITIES, CLAIMS OF THIRD PARTIES, DAMAGE TO PROPERTY RESULTING FROM THE PURCHASE OR USE OF THE PRODUCT OR ARISING FROM THE BREACH OF THE WARRANTY, BREACH OF CONTRACT, NEGLIGENCE, STRICT TORT, OR ANY LEGAL OR EQUITABLE THEORY, EVEN IF OXY PTY LTD KNEW OF THE LIKELIHOOD OF SUCH DAMAGES. OXY PTY LTD SHALL NOT BE LIABLE FOR DELAY IN RENDERING WARRANTY SERVICE.

# Appendix 1

## MEDICAL STATEMENT FOR DIVERS

Please note: Positive responses to questions do not necessarily disqualify you from diving. Any points of uncertainty should be discussed with your doctor.

**DIVERS PLEASE FILL THIS OUT**

**IMPORTANT:** Are you flying within the next 24 hours? YES or NO

Please answer the following questions on your past or present medical history with a YES or NO. If you are not sure, answer YES. If any of these items apply to you or you are not sure, we must request that you consult with a doctor prior to participating in SSBA diving. Please take the filled Medical Statement to your doctor.

Please Tick: Have you had / or do you suffer from any of the following:

	YES	NO	COMMENTS
Asthma or wheezing			
Chest surgery			
Chronic bronchitis			
Diabetes mellitus (sugar diabetes)			
High blood pressure			
Illness or operation within the last month			
Pregnant or planning to be			
Consumed alcohol within 8 hours before diving			
Are you taking a prescribed medication or drugs			
Major joint / back injury			
Any medical problems not listed here (please write here)			
Fainting, seizures or blackouts			
Collapsed lung (pneumothorax)			

When was the last time you dived?	Date:	How many logged dives to date?
-----------------------------------	-------	--------------------------------

### DIVER'S WAIVER

I understand that I should be in good mental and physical fitness for SSBA diving, SCUBA diving and snorkelling, and that I won't dive under the influence of alcohol or any drugs that are contrary to SSBA diving, SCUBA diving or snorkelling.

- I fully understand that asthma, epilepsy, any recent surgery, most prescription medications, heavy colds and flu within the last 10 days, are reason not to dive. I further fully understand that recent alcohol consumption and use of recreational drugs also are reasons not to dive. I understand that the above-mentioned conditions and practices contribute to factors which can lead to decompression illness or

embolisms even when all SSBA or SCUBA diving practices are performed correctly and within the limits of recreational no-decompression diving.

- If I am taking medication, I declare that I have seen a physician and have approval to SSBA or SCUBA dive/snorkel while under the influence of the medication/drugs.
- I understand that skin and SBBA or SCUBA diving are physically strenuous activities and that I will be exerting myself during this activity and that if I am injured as a result of heart attack, panic, hyperventilation, etc., that I assume the risk of said injuries and that I will not hold the Released Parties responsible for the same.
- I understand that concealment of any medical or physical condition might put my life or health or the life or health of others at risk.
- I accept that the activities may involve strenuous physical activity even in calm water and that older people are at an increased risk of death and injury due to a higher incidence of medical conditions made worse by physical exertion, such as heart disease and stroke.
- It has been recommended to me that I obtain my own accident insurance to cover me whilst diving.

#### DIVER RELEASE

In consideration for the SSBA dive being undertaken the person, for themselves and for their estate, hereby releases, discharges, waives and relinquishes any and all suits, claims, actions, causes of actions of the like against OXY PTY LTD (“The Company”) and its servants or agents in respect of any loss or damage suffered by the person as a result of delay or cancellation of any SSBA dive or for any loss or damage to the person or property of the person sustained during the SSBA dive or otherwise in connection therewith including but not limiting to, loss or damage suffered during or as a result of the person having engaged in SSBA diving activities whether such loss or damage was caused or contributed to by any equipment supplied and/or serviced by the Company, its servants or agents and whether loss or injury was caused or contributed to by any negligence or breach of duty on the part of the Company, its servants or agents or otherwise.

The person acknowledges that these conditions have been drawn to their attention and that they form part of the contract between the person and the Company.

Your doctor should check this form and may declare as a result that you need a full medical before diving. He/She may decide that you should not dive. To do so may put your life at risk or that of the employee of OXY PTY LTD. In the interest of your safety it is important that you complete all answers to every question.

I have read and fully understand the information on this form. I certify that the information given on this form is true and correct to the best of my knowledge and that I realise that any failure on my part to provide complete and accurate information on my medical history could result in death or serious injury being suffered by me should I proceed with diving activity.

Signature		Date	
Under 18 years print name in full			



