

# PORTABLE MISTING FAN MANUAL

---



**MCS PRODUCTS**



**CAUTION**

- Carefully read and understand the entire technical manual before attempting to install, operate, or perform maintenance on this equipment.
- Contact your supplier if you do not understand these instructions.
- Failure to follow these instructions may lead to serious injury or death.
- Retain these instructions for future reference.

**All operators are to read and understand this manual.**

---

# Table of Contents

- Overview of Fan Tech High-Pressure Misting System ..... 5
- Start-up and Operation Procedures..... 5
- Maintenance ..... 7
- Troubleshooting..... 8
- Replacement Parts ..... 10
- Consumable/Common Parts..... 10
- Warranty ..... 11
- Appendix ..... 12
  - Parts Diagram..... 12
  - Control Panel..... 13
  - Fan Controls ..... 13
  - Nozzle Components ..... 14

---

## Overview of MCS High Pressure Misting Fan

Thank you for choosing MCS Products as your provider for high-pressure misting systems. MCS Products is devoted to providing its customers with reliable high-pressure cooling systems engineered with quality components to meet their cooling needs.

Our high-pressure portable misting system provides superior cooling by combining small orifice misting nozzles with a high pressure pump to create a very fine mist or fog. This fine mist will quickly evaporate reducing the temperature of the ambient air. MCS pairs the misting system with durable fans to reduce the temperature in the desired location.

## Start-up and Operation Procedures

High-pressure misting systems require both electrical and water to function properly. Electrical connections are needed to provide power to the pump motor and the fan motor. Use the proper electrical source to ensure the system will operate correctly. Contact a certified electrician to verify the proper installation if necessary. The water should be supplied to the tank through the garden hose connection on the back of the unit.

**1. Connect the water supply to the 3/4" female garden hose adapter on the back of the unit.** The water supply should meet the following conditions:

- Flow rate of 1GPM or more
- Water less than 7.5 pH
- Pressure between 15-75 PSI
- Dissolved solid content less than 500 PPM

Possible damage from improper water supply includes:

- Clogged misting nozzles or filters due to solids in water.
- Black or galvanized steel pipe fittings; only use hose and pipe fittings compatible with water to prevent corrosion.
- Pump damage may occur due to fluctuations in the water supply, clogged nozzle, or closed off discharge side of pump. Never attempt to operate the pump with no water supply connected.

**2. Connect the proper power supply.** The MCS system is equipped with a 15amp 110v plug. The amp requirements are located on the motor plates of both the pump motor and fan motor. Do not use unapproved extension cords or adapters to connect the system. Common electrical systems have plugs only rated to 15 amps. Common breakers are overloaded at 20 amps. Consult a certified electrician if you are unsure about your power supply.



**WARNING**

**ELECTRICAL SHOCK HAZARD: Serious injury or death is possible  
Only connect the power supply plug to a properly grounded receptacle.**

---

### Initial operation and start up of the system

3. Turn on the water supply and allow the tank to begin to fill up. The unit may be operated with the water supply connected or disconnected. If operating with the water supply disconnected, wait for the tank to fill up and then turn off the water supply and disconnect the garden hose. The user can identify when the tank is full by using the clear sight tube. If operating with the water supply connected, simply leave the water supply on. Once the tank is full a valve will automatically shut off the water supply preventing the tank from overflowing. The valve will also open when the tank requires more water. Press the “ON” button on the back of the unit to activate the pump. If the “Warning” light is on press “OFF” to see if it disappears. If the light persists please see the troubleshooting section. After pressing “ON” wait for 15-20 seconds for the motor and pump to activate, the delay is because the water must enter the system. If after 20 seconds the system does not work, turn off the pump. Running the pump without a water supply will destroy the pump. If air is trapped in the system it may be necessary to open the evacuation valve when turning the system “ON”, see appendix for ball valve location. See the troubleshooting section if the system fails to operate. The mist should form a cone shape when exiting the nozzle. If the cone is not even, or if the nozzle appears to be leaking, see the troubleshooting section.



**CAUTION**

**Do not increase the system pressure above 1000 PSI. Damage to internal components may occur.**

### Turning on the Fan

4. Connect the fan to a proper power source. To begin the operation of the fan, turn the knob on the fan to your desired speed. Fans have three different speeds and an oscillator that may be switched ON or OFF. Fan speed may also be controlled by the knob on the back near the tank. Place the fan in the desired location and lock the wheels in place to prevent the fan from moving during operation.



**WARNING**

**ELECTRICAL SHOCK HAZARD: Serious injury or death is possible  
Only connect the power supply plug to a properly grounded receptacle.  
PINCH HAZARD: Do not operate fans without guards in place. Do not  
insert anything into fan guard while the fan is operation.**

### Turning off the system

5. Shut off the fan by the knob to the “OFF” position. Turn off the pump by pressing the “OFF” button on the back of the unit. The nozzles should stop emitting the mist immediately. If the nozzles are still dripping, high pressure water may still be in the line and can be relieved by opening the evacuation valve on the back of the unit, see appendix for exact location.

---

## Maintenance

**1. Nozzles.** Nozzles should be checked regularly to ensure the best misting performance. The mist or fog should emit from the nozzle in an even cone shape. If the mist is not an even cone shape the nozzle needs to be cleaned or replaced. To clean a nozzle, first remove it from the misting ring. Disassemble the nozzle and soak the nozzle tip and impeller in ZEP, CLR, or vinegar. Do not soak the spring or the body of the nozzle. After soaking, rinse with water and reattach to the misting ring, do not use tools. The nozzles should function properly when screwed in by hand.

**2. Pump.** The pump requires an initial oil change after 50 hours of service, and additional oil changes every 3 months or 500 hours. Use 8.5 oz of ISO68 hydraulic oil. When changing the oil disconnect the electricity to the system. Do not run the pump without oil in the crankcase. Check the seals and valves for wear after 1000 hours. Check immediately if the systems performance decreases.

**3. Filters.** The filters should be checked frequently and replaced if needed. The filter life depends on the water source. If the filter is dirty replace immediately because it is restricting water flow to the pump and may damage the system. To check the filter, simply unscrew the housing from the top bracket. When replacing the filter it is also good practice to clean the housing with bleach. Use a few tablespoons of bleach mixed with water and scrub the inside of the housing. Make sure the o-ring is in place when reattaching the housing to the bracket, then hand tighten and check for leaks.

**4. Storage.** When storing the system for more than a few days or transporting the system, it is important to drain the water. Draining the water prevents calcification problems or the formation of algae. Drain the system by opening the evacuation valve and relieving the pressure in the system. It may be necessary to tilt the system to drain all the water. Also drain the filter housing to preserve the filter. Store the unit in a dry location with ambient temperature. Avoid areas that are subject to excessive heat, dust, humidity, freezing, or damage from nearby equipment. If freezing conditions are possible flush your pump with a 50/50 solution of anti-freeze/water. Also drain any supply hoses.

For initial operation after a long duration of non-use it is necessary to flush the system of particles. Remove the nozzles from the nozzle rings and place the system in a water safe environment. Power up the system and allow water to flow through the nozzle openings for a few seconds. After flushing the system, reattach the nozzles by tightening them by hand.

## Troubleshooting

Problem	Potential Cause	Corrective Action
Fan will not run.	Power supply Connections	<ul style="list-style-type: none"> <li>- Confirm the control knobs are in the ON position.</li> <li>- Confirm the power cords are connected.</li> <li>- Confirm that the power supply is on.</li> </ul>
Misting rings will not mist.	Manifold line attached.	<ul style="list-style-type: none"> <li>- Confirm the fittings are securely attached.</li> <li>- Confirm it has a water supply.</li> <li>- Confirm control switch is in the ON position.</li> </ul>
Surfaces get wet.	Pump not operational.	- Review pump troubleshooting guide.
	Pump malfunction.	- Relocate the fan.
	Mist is too close. Optimum evaporation occurs at least 10 ft. from the fan.	<ul style="list-style-type: none"> <li>- Use the low speed setting on the fan. Order plugs to reduce the amount of mist.</li> </ul>
	Too much mist being produced for the environment.	<ul style="list-style-type: none"> <li>- Plug additional nozzles while maintaining the minimum required for safe pump use. Minimum is 4 nozzles. Use regulator valve to adjust pressure to 1000 PSI.</li> </ul>
Nozzle leaks during operation.	Nozzles are clogged.	<ul style="list-style-type: none"> <li>-Remove debris from nozzle tip by cleaning.</li> </ul>
	Nozzles are loose.	<ul style="list-style-type: none"> <li>-Turn off the system and relieve pressure to the mist rings, and then hand -tighten nozzles.</li> <li>- Check ball in anti-drip body for debris and replace if necessary</li> </ul>
Pump will not run.	Nozzle o-ring is worn.	<ul style="list-style-type: none"> <li>- Plug in power supply to pump.</li> <li>- Turn ON supply power to pump.</li> </ul>
No water supply.	Ant-drip parts may be worn. Power cord is unplugged. Power supply is OFF. Water supply is Empty or OFF.	<ul style="list-style-type: none"> <li>- Turn ON supply water to pump or fill the tank.</li> <li>- Confirm correct voltage and amperage is being supplied.</li> </ul>
	Circuit breaker OFF.	<ul style="list-style-type: none"> <li>- Confirm the supply water has a pressure between 15-70 PSI.</li> </ul>
		<ul style="list-style-type: none"> <li>- Inspect filter. Replace dirty filter which restrict flow.</li> </ul>
Pump stops running.	Power supply interrupted.	<ul style="list-style-type: none"> <li>- Check electrical connection at the solenoid valve.</li> </ul>
	Solenoid valve is not open.	<ul style="list-style-type: none"> <li>- Check diaphragm of the solenoid valve. Restore power.</li> </ul>

Circuit breaker switched off.		- Confirm breaker is not being overloaded or is not worn. Re-size or replace if faulty.
Drought Switch Activated.		- Confirm the supply water has a pressure between 15-70 PSI. A shared water supply may decrease water pressure. Inspect filter. Replace dirty filter which restrict flow. - Check electrical connection at the drought switch. - Never operate the pump above 1000 PSI.
Pump motor overheated.	Pump motor may be damaged.	- Confirm proper ventilation is available to the pump motor.
Circuit interrupter is tripped.		- Confirm voltage and that the motor is within the service factor.
Pump chatters.	Pump head may be damaged. Pump is being starved of water.  Broken or worn bearing.	- Press reset button on pump motor.  - Motor bearing may have caused pump to seize. Have service shop inspect and replace if necessary. - Motor may have shorted or been overloaded. Have service shop inspect.  -Crank bearing/connecting rods may be damaged. Have a service shop inspect.  - Insure that clean water is being supplied, especially at system start-up.
Pump leaks.	Stuck inlet/discharge valves.	- Check for clogged pipes or tubes. Have service shop inspect and replace if necessary.
Pump is on but no mist is produced.	Water is leaking.  Oil is leaking.  Pressure regulator turned low.  There may be a leak in the system.  There may be an air-lock.  The pump's pressurization components may be damaged.	- Have service shop inspect valves and replace if necessary. - Have service shop inspect seals and replace if necessary. - Tighten filler cap and drain plug. Fill crankcase to specified capacity. - Have service shop inspect seals and replace if necessary. - Turn pressure regulator clockwise to increase the pressure. Do not exceed 1000psi. - Confirm that nozzles are intact. - Check for loose hose fitting in manifold line. Open the evacuation valve to release any air-lock. This is true if the pump makes a clicking sound. The pump head can be rebuilt, have a service shop inspect.

---

Water sprays from nozzles  
after system is shut down.  
Filter housing leaks.

Anti-drip not functioning.  
O-Ring failure.

- Check integrity of anti-drip ball and spring.
- Inspect placement and integrity of o-ring. Replace if necessary.

## Replacement Parts

Replacement parts available at [www.mcs-products.com](http://www.mcs-products.com)



## (1) YEAR LIMITED WARRANTY

*All MCS Products are warranted for a period of one (1) year for defects in workmanship and materials under normal use and service. This warranty is extended solely to the original purchaser. In order to initiate this warranty, the Product Registration Form must be completed and sent to MCS, along with a copy of the purchase invoice, within 30 days of purchase.*

**In General:** If a product fails because of defect in material or workmanship under normal use and maintenance within one year from date of purchase, we will, at our option and after inspection, repair or replace the defective product.

**About your Warranty:** Fan products, like all mechanical devices, need periodic parts and service to perform well. Normal use and service means not to operate in excess of recommended maximum speeds, pressures, temperatures or using fluids not recommended or compatible with component materials.

This warranty does not apply to any component which has been repaired or altered to affect the performance or reliability of the product. Similarly, the warranty is void if the manufacture date or the serial number has been removed or if the equipment has been altered or modified.

MCS Products does not warranty components due to normal wear including nozzles, pumps, motors, and seals. MCS does not warranty components due to misuse, abuse, neglect or improper maintenance, shipping, handling, warehousing or improper installation. This warranty excludes wear items such as water filters, spray nozzles, or pumps that have been run without water supplied; damage or malfunctions resulting from accidents, abuse, modifications, alterations, or improper servicing or freezing or chemical deteriorations. This warranty excludes failures due to acts of God and other force majeure events beyond the manufacturer's control.

This warranty does not cover normal maintenance such as oil changes, water filters, adjustments, or cleaning, etc. This warranty does not cover damage from lack of maintenance (lack of oil or water filter changes) freezing, and obstruction (due to scale, lime, dirt, chemicals, etc.)

**Claims:** All warranty claims must be submitted to MCS Products prior to the expiration of the warranty period. MCS Products will repair or replace any part of the fan product that is defective in material or workmanship. In order to initiate this warranty, the Product Registration Form must be completed and sent to MCS Products, along with copy of original purchase invoice, within 30 days of purchase. Transportation charges on the product submitted for warranty must be borne by the purchaser. For warranty service, call MCS Products for a Return Goods Authorization (RGA) number. Products shipped collect or without an RGA number will not be accepted.

If MCS determines that the problem with the product is not due to defects in workmanship or materials, the customer will be responsible for the cost of any repairs and any freight expense to return the product to the customer.

If the product is covered by this manufacturer's warranty, then MCS will pay the freight to send the product back to the customer within the 48 continental United States ONLY.

**No Other Warranties and Liability Limitation:** This limited Warranty and Policy represents MCS Products sole and exclusive warranty obligation with respect to MCS Products. MCS Products liability to a customer or any other person shall not exceed the purchase price of the MCS product. MCS disclaims all other expressed and implied Warranties including the implied Warranties of fitness for a particular purpose and merchantability.

*There is no other express warranty. Any and all implied warranties are excluded. Liability for incidental or consequential damages are excluded to the extent exclusion is permitted by law. This warranty gives you specific legal rights and you may also have other rights which vary from state to state and country to country.*

## Appendix

### Parts Diagram

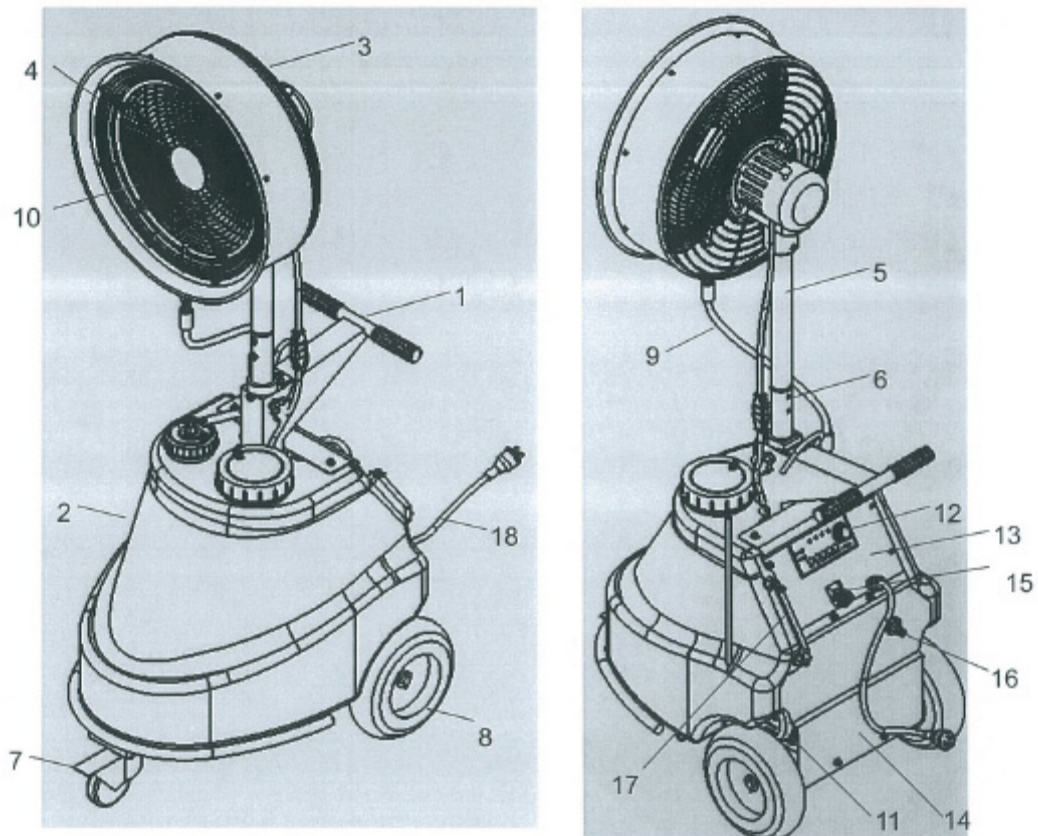

1	FRAM BRACKET	11	PUMP
2	WATER TANK	12	CONTROL PANEL
3	FAN	13	UPPER LID
4	STAINLAESS STEEL FRONT MESH	14	BACK LID
5	FAN SUPPORT PIPE	15	WATER INLET (5"PP FILTER)
6	FAN HEIGHT ADJUST SCREW	16	EVACUATION VALVE
7	4" FRONT WHEEL	17	WATER LEVER GAUGE
8	10" REAR WHEEL	18	POWER CORD
9	HOSE		
10	FOG RING		

## Control Panel

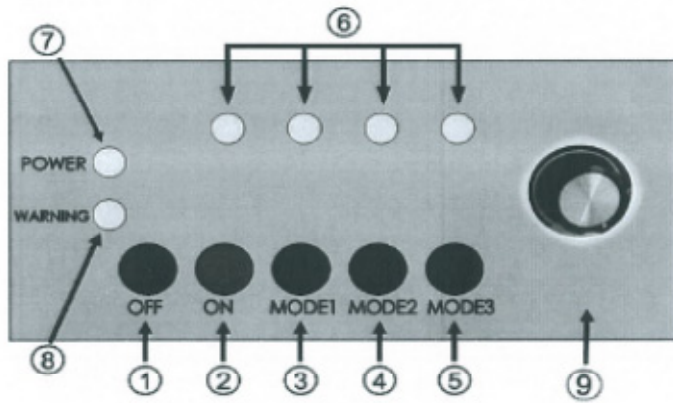

No.		Description
1	OFF	Power Off
2	ON	Continuous misting
3	MODE 1	Mist: 30 seconds / Stop: 30seconds
4	MODE 2	Mist: 40 seconds / Stop: 40 seconds
5	MODE 3	Mist: 50seconds / Stop: 50 seconds
6	INDICATOR LIGHT	Operating mode
7	POWER	Power On
8	WARNING	Indicator light: Lack of water supply
9	FAN SPEED	Adjust fan speed

## Fan Controls

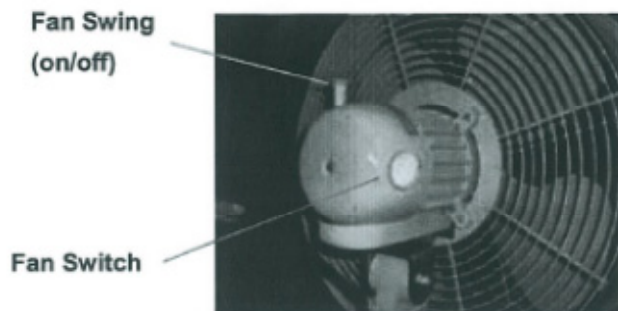

Nozzle Components

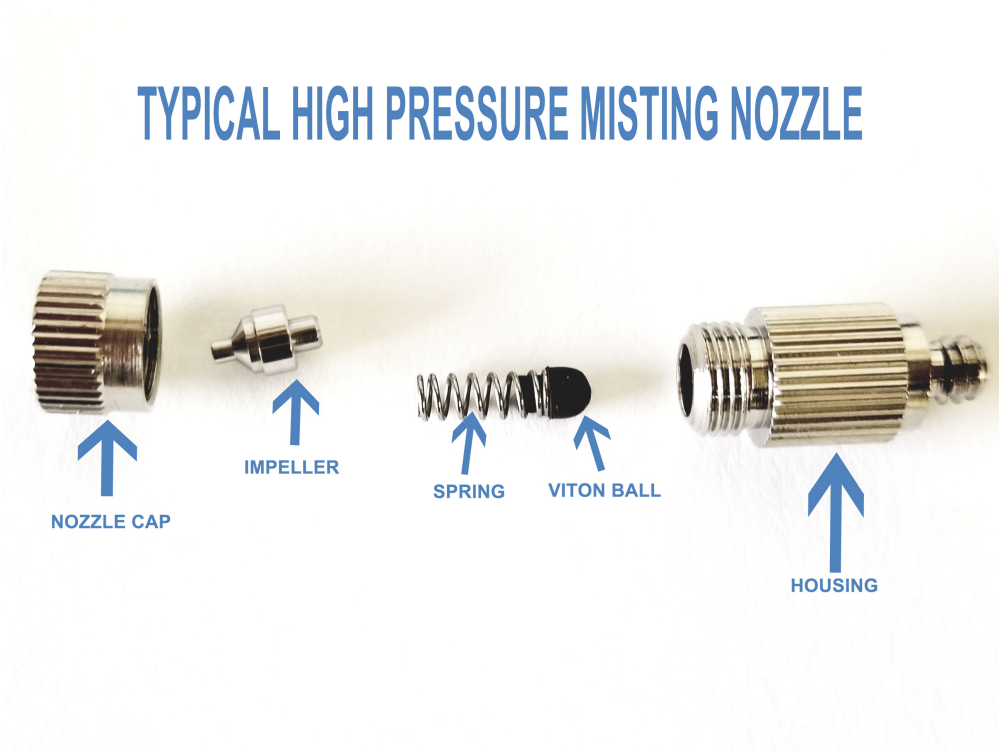

MCS Products, LLC.

13200 Pond Springs Road, Suite  
A106  
Austin, TX 78729

Toll-Free (844) 344-2069