

EVEBASE

USER MANUAL

POWER STATION MOVE 1200



CONTENT

SAFETY INSTRUCTIONS	3
AC OUTPUT PARAMETER	5
PRODUCT INTRODUCTION	6
LCD DISPLAY	8
UPS MODE	9
SOLAR PANEL CHARGING	10
CAR CHARGING	10
PRODUCT SPECIFICATIONS	11
BATTERY SPECIFICATIONS	11
PROBLEMS AND RESOLUTIONS	12





SAFETY INSTRUCTIONS

Please read this manual carefully. The user of this product takes full responsibility for the operation and usage of this product. Please check the local regulations in the area of usage of the product. The user of this product is solely responsible for the usage of this product according to all relevant regulations.

1. In order to ensure the safety of this product during transportation, this product is only charged about 30% when it is packaged. Please recharge when you get the product. When not using this product, please turn off the power and unplug the power cord.
2. Only official parts or accessories can be used with this product. If any accessories need to be replaced, please contact Evebase for more information. Do not charge the product with a charging device that does not meet the specified parameters and please do not use extension cords and cable taps.
3. Do not disassemble the product and don't perforate it with sharp objects.
4. A high environmental temperature while using the power station may result in fire or an explosion. Therefore please follow the maximum operating temperature as specified further in this manual. If the temperature is too low, the performance of the product will go down or the product will stop working.
5. Only use and store the product in dry and ventilated areas and avoid dust. Please ensure that the air intake and outlet are unblocked when using.
6. Strictly avoid contact of the product with any liquid. Do not immerse the product into water and make sure it doesn't get wet. Avoid the usage in rainy or humid places.
7. In case the power station has fallen into water or is wet, place it in an open area and keep a safe distance until it has dried entirely. As soon as the product is dry again, it can't be used anymore and has to be disposed according to the applicable local regulations. In case the power station catches fire, it has to be extinguished in the next order: water → sand → fire blanket → dry powder → carbon dioxide fire extinguisher.
8. Only use the product on flat surfaces in order to protect the product from falling over. Immediately stop operating/using the product after falling or other external impact on the power station and avoid strong vibrations during use. Turn of the power supply immediately after any strong impact and place the battery in a safe and open area. Finally, dispose the product according to the local regulations.
9. Only use a dry textile to clean the outside of the product.
10. Please keep the product out of reach from children and pets.
11. In case the product is used for the operation of standard medical equipment, please make sure the power status is monitored carefully, in order to prevent that the power runs out. Please contact Evebase about any restrictions for the use with medical equipment.
12. Please make sure there is a safe distance between medical implants and the power station, as this product will generate an electromagnetic field. Please contact Evebase if you need more information about any restrictions.
13. Avoid usage in a strong static electric/ magnetic field.

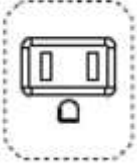
14. Avoid usage/ storage near any heat source (fire, car in direct sunlight etc.).
15. Don't use any wires or metal objects that can result in a short circuit.
16. No items can be stacked on top of the product.
17. If the battery is swollen, leaking or smelly, stop using it immediately.
18. Please make sure the power station is completely discharged before disposal in an official battery recycling bin. It is prohibited to dispose the product in a standard trash can. Please follow the local regulations.
19. Please contact a professional battery recycling company in case the power station can't be discharged completely due to a failure.
20. For long-term storage, please consume power from full power to no power once every 3 months, and then recharge to about 50%.
21. Please avoid shipping a product with a battery power level higher than 30% and don't take it on a plane.

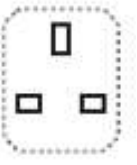
AC OUTPUT PARAMETER

Type of AC port	AC output
 US/JP	100V~120V 50/60Hz
 CH	220V 50Hz
 UK	230V 50Hz
 EU	220V~240V 50Hz
 KR	220V 60Hz

PRODUCT INTRODUCTION

This product is a high power portable power station, suitable for family emergency power cuts, outdoor travel, emergency relief, field work and other scenarios.

The product has a built-in LiFePO4 battery, which supports adapter, car charger, photo-voltaic panel and other charging methods. The AC output voltage corresponds to different national specifications (see previous page) and a number of USB ports supply for lighting, ventilator, electric fan, router, notebook and other equipment. Thanks to the 1200W high power maximum output and pure sine wave AC output this power station can even be used for most household appliances.

Through the 700W ultra-fast charging, this model can be full charged within 1.5 hours. The AC input/output voltage frequency can be switched automatic or manually between 50Hz/60Hz. This product also supports maximum 500W solar charge, allowing you to charge the device, even without access to a power grid.

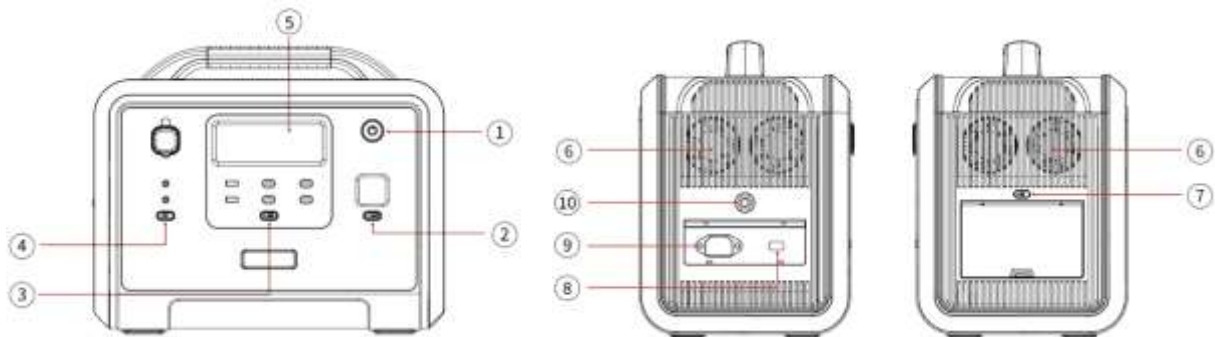

- | | | | |
|---|--------------------|----|---|
| 1 | Main power control | 6 | Air intake/outlet |
| 2 | Light control | 7 | AC on/off control (50Hz/60Hz switching control) |
| 3 | USB control | 8 | Anderson input (solar panel) |
| 4 | DC control | 9 | AC input port |
| 5 | LCD display | 10 | Overload protection |

1. Main power control

Operate method: Press the main power control button for 3 seconds to turn the system on/off



2. Led light control

Operate method: Shortly press the button to turn it on and to change the light mode (SOS/Flash).

You can turn off the light by pressing the button for 1-2 seconds in any mode.



3. USB button

Operate method: short press to turn on/off

 USB-A × 2	 TYPE-C × 1	 TYPE-C × 3
5V/2.4A	PD-100W	PD-20W

4. DC button

Operate method: short press to turn on/off.

 Output ×2	 Cigar Lighter ×1
12V/3A	12V/10A

5. LCD display

The display shows the remaining power and different using data.

6. Cooling system

When the fans are working, please do not block the channel.

7. AC button (AC output, total combined 1200W)

Operate method: short press to turn on/off.

- Note:
1. Please check the output voltage or frequency before using
 2. Press the button for 2 seconds to enter the frequency changing mode. 50Hz and 60Hz will flash on the display. Press the button again to choose the correct frequency. Wait until the frequency stops flashing.

8. Solar panel input

Use the Anderson port to connect the solar panel.

1. Solar panels can have a maximum input of 500W and a maximum voltage of 50V
2. Exceeding the maximum voltage will lead to damage on the equipment. This is beyond the scope of warranty.

9. AC input

Use a wall socket in order to get to 700W fast charging. This fully charges the device from 0-100% in 1,5 hours.

- The product can be charged directly by the wall socket, but please avoid the use of extension cords and cable taps. When the product is charging, please do not plug other devices in the same socket.
- Do not plug several devices together in an extension socket at once. The current will be too high and bring damage to the cable, which may result in fire.
- Do not use the same socket to connect other devices when charging this product. When the same wiring in a general household exceeds 1500W, the safety circuit breaker will be activated.

10. Overload protector

An overload protector is added in order to protect this product. This prevents damage to the product due to excessive AC input current, caused by lightning and power grid fluctuations. When such a situation occurs, the overload protector will start to cut off the AC input to protect the product.

Restore the AC input function of the product with the following steps:

1. Turn off the power and unplug all ports.
2. After confirming that all parts are normal, turn on the power button.
3. Press the overload protection button to switch on the AC line to restore AC input.

LCD DISPLAY

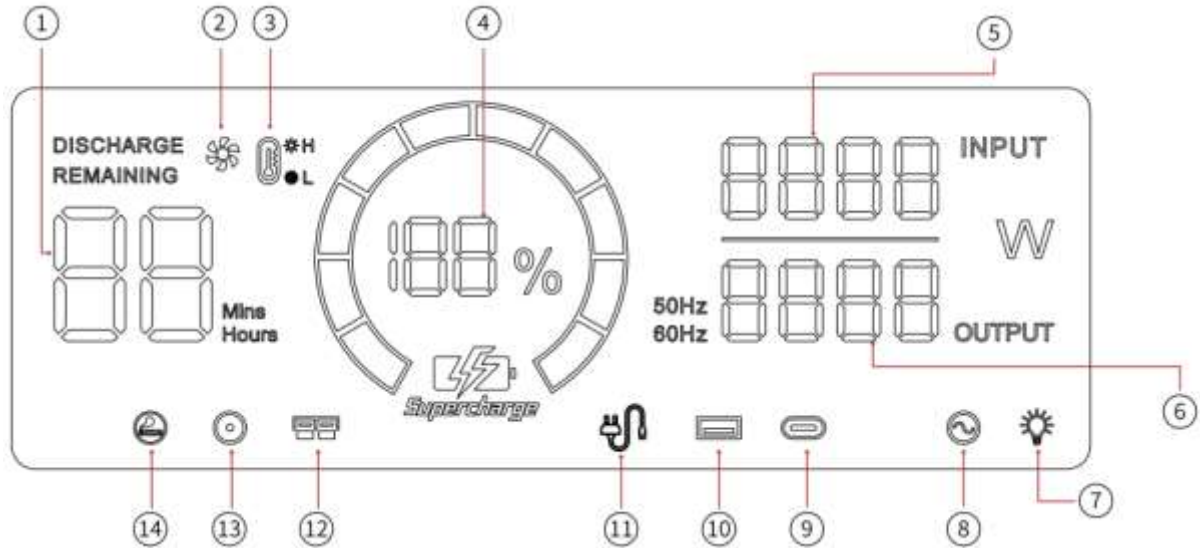

- | | | | | | |
|---|---------------------------------|----|--------------------|----|-------------------|
| 1 | Charging/ using time | 6 | Total output power | 11 | AC charging |
| 2 | Fan state | 7 | LED light | 12 | Anderson charging |
| 3 | High/low temperature protection | 8 | AC output | 13 | DC output |
| 4 | Power percentage | 9 | Type-C output | 14 | Car port output |
| 5 | Total input power | 10 | USB output | | |



When this icon lights up, please keep the air intake/ outlet unobstructed.



When this icon lights up, please note that the operating temperature of the device is too high or too low. The device will possibly stop working until the temperature is back to the normal standard.



When this icon is flashing, it shows that the AC input is wrong. Please check the power cable.



When this icon is flashing, it means the output is wrong.

UPS MODE

This power station has a built-in “bypass mode” functionality, meaning that in case of a power grid shut down, the power station automatically switches (within 10ms) from the power grid to the internal battery capacity to supply power.

As demonstrated in the picture below, you can connect the power station between the wall socket and your electrical appliances. When you turn on the electrical appliances, they will directly use the AC power from the wall socket (power grid) and don't use any of the battery capacity.

When the power grid is cut off, it will immediately switch to the internal battery capacity, in order for you to keep on working. Ewebase is not responsible for any abnormal operation or data loss caused by careless use.

- In case the power station jumps into UPS mode in Europe or the United Kingdom and the AC output exceeds the maximum power of 1200W, the AC output icon  will start to flash, indicating overload.

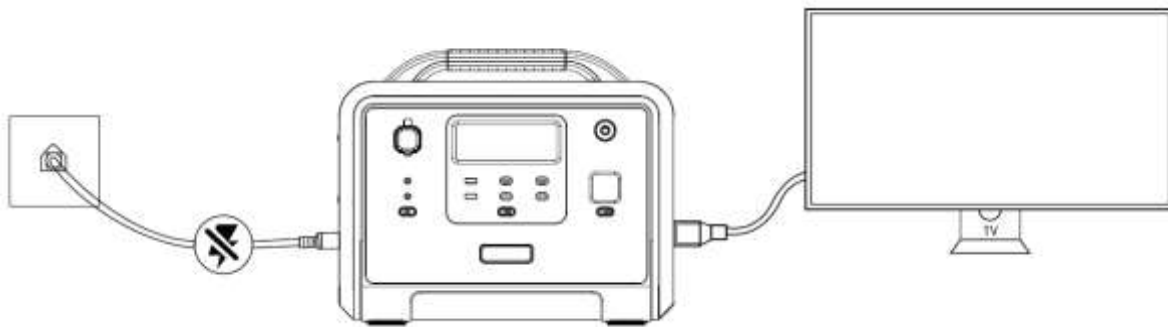

SOLAR PANEL CHARGING

The product can be charged through solar panels. Maximum solar panel input is 500W (maximum 50V voltage).

- The solar panel charging power may fluctuate according to the weather conditions.
- Solar panel voltage exceeding 50V will damage the equipment and isn't covered by warranty.

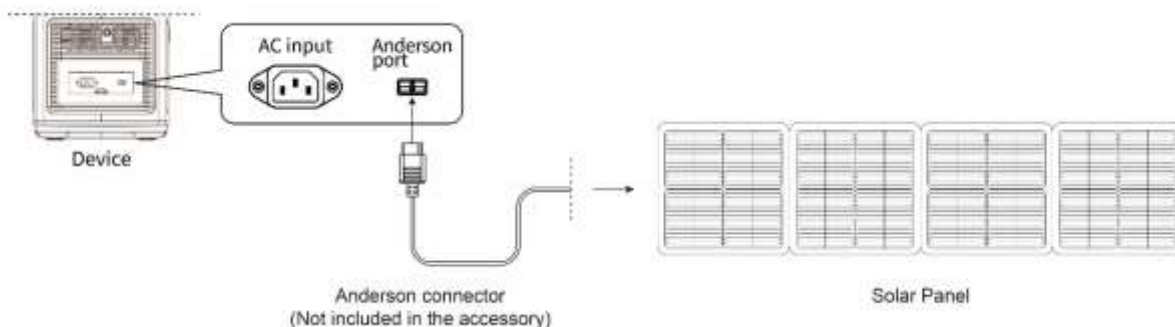

CAR CHARGING

This power station can be charged by the cigarette lighter in the car, with an ACC cable. Turn on the power of this power station, connect the ACC charging cable to the cigarette lighter in the car and to the Anderson interface on the side of the power station. After starting the engine of the car, the LCD screen of the power station will show the input power.

- On-board charging should be carried out with the car engine turned on. If the engine of the car is not turned on, the battery of the car might run out.
- The charging time while charging by car is long, due to the low power output of 90-120W.

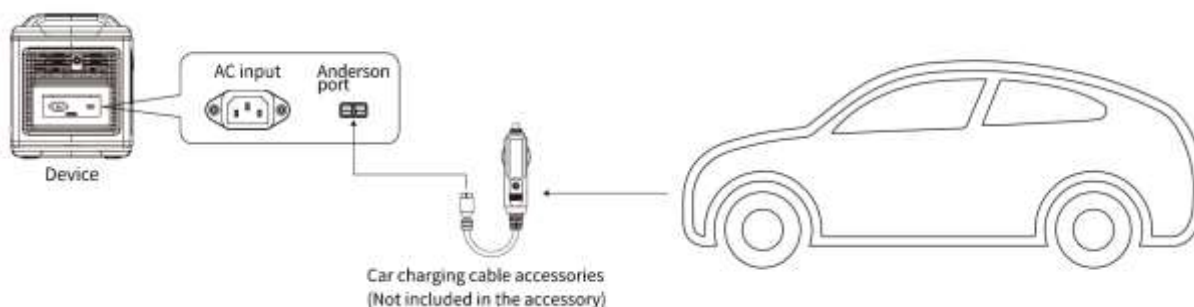



PRODUCT SPECIFICATIONS

Product name	EveBase Power Station Move 1200W
Product dimensions	L*W*H = 386*225*317mm
Product net weight	12,5 kg
Rated capacity	960Wh
AC Charging	50/60Hz 700W max
MPPT input	11.5-50V 500W max
AC Output	50/60Hz (frequency switch available), rated 1200W, peak 2400W, pure sine wave. Built-in overload and short circuit protection.
USB	USB-A (5V 2.4A) x2
Type-C	5-20V/5.0A, PD3.0 100W x1 ; 5-12V, PD 20W x3
DC5521	12V/3A x2
Car port output	12V/10A
Power off current	<500uA
Operating temperature	-10°C ~ 40°C
Charging temperature	0°C ~ 40°C
Working environment humidity	<90%RH

BATTERY SPECIFICATIONS

Type of battery	32130 LiFePO4
Single cell rated voltage	3.2V
Single cell rated capacity	20Ah
Battery pack rated voltage	48V
Battery pack output voltage range	42-54V
Battery pack rated capacity	960Wh
Battery pack maintenance	If not used for 3 months, product should be recharged.

PROBLEMS AND RESOLUTIONS

Status	Possible cause	Resolution
 <p>Above icons flash and buzzing alarm.</p>	Exceeding standard output, short circuit.	<ol style="list-style-type: none"> 1. Remove the load. 2. Check if the overload protector is up. If it is up, press the overload protection button and press the AC button. 3. If the overload protector doesn't jump up, directly press AC output restore output function.
 <p>Above icon flashes and buzzing alarm.</p>	The equipment temperature is too high or too low.	<ol style="list-style-type: none"> 1. Remove the equipment and turn off the power of this product. 2. Restart the machine when it is cooled down. 3. Place the equipment in a -10°C ~ 40°C environment. 4. Please check if the fan is running normally and is ventilated.
 <p>Charging unavailable</p>	The adapter has a poor connection.	Confirm the connection status of the cable and the power supply status.
	Overload protection function activated.	<ol style="list-style-type: none"> 1. Turn off the power button and remove cables from all ports. 2. After checking if all components are normal, turn on the power button. 3. Press the overload protection button to connect the AC cable to recover AC input.

EveBase Tech B.V.
 Oostwal 2
 1747 EZ
 Tuitjenhorn
 The Netherlands

support@evebase.com
 www.evebase.com

Designed in NL. Made in PRC.