

## OUTER PANEL

### POSITIONING

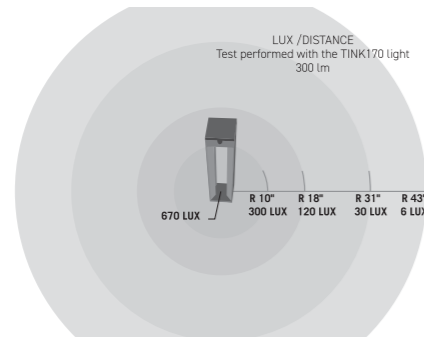

Example of positioning in Aix-en-Provence. Expected performance in the middle of each month. Hypothesis: 1.8-W panel and new battery.

Month	Recoverable energy in Wh	Length of night in hours	Brightness in lm (mode 1)	Average battery life at 300 lm in hours
January	72	13:40	39	01:20
February	103	12:30	62	01:55
March	165	11:10	111	03:05
April	208	09:35	129	03:52
May	250	08:10	152	04:40
June	271	07:30	165	04:45
July	281	07:30	165	04:45
August	243	09:00	138	04:32
September	180	10:30	118	03:22
October	124	12:00	77	02:19
November	77	13:15	43	01:26
Décember	62	13:55	33	01:09

### MAINTENANCE AND CUSTOMER SERVICE

Clean the solar panel frequently with a damp cloth.

Questions regarding the repair and maintenance of your product, contact us by e-mail at [contact@lesjardins.us](mailto:contact@lesjardins.us) or call 1-833-JARDINS

### TRANSPORTATION

Lithium-ion batteries are subject to regulations concerning the transport of dangerous goods. The user may carry the batteries by road without taking additional measures. When dispatched by a third party, (e.g., air carriers or haulage companies), the specific measures printed on the packaging must be observed.

### WASTE DISPOSAL

The ASB, as well as its accessories and packaging, should all be recycled in an appropriate manner. Do not throw the ASB out with your household waste!

**EPA recommendation: Find a location to recycle Li-ion batteries and products that contain Li-ion batteries on the [epa.gov](http://epa.gov) website; do not put them in the trash or municipal recycling bins.**

### WARRANTY

This product is guaranteed for 1 year against all manufacturing defects. The code on the side of the ASB must be legible for the warranty to be valid. This warranty does not cover any misuse or of damage to the product.

#### Disclaimer

The warranty is held to be invalid in the following circumstances: if there are visible cracks or scratches on the product, or invisible electronic damage caused by an impact; full immersion; incorrect installation of batteries, or use of a different brand; purchase of the product more than 1 year prior to the claim.

[www.lesjardins.solar](http://www.lesjardins.solar)  
Follow us on social media!



Made in P.R.C.  
IMPORTED BY:  
Les Jardins Americas  
3850 Greenhill Road  
Pasadena, CA 91107 - USA

**LES JARDINS®**  
HIGH EFFICIENCY SOLAR LIGHTING

## AUTONOMOUS SOLAR BULB ASB300 2.0

### USER GUIDE

### SAFETY PRECAUTIONS

It is essential to read all safety guidelines and instructions. Not respecting the warnings and instructions set out hereafter may cause fire and/or serious injury, and loss of warranty.

- > Do not point the beam of light towards persons or animals, and never look into the beam of light, even if you are far away from it.
- > Only the manufacturer or specially qualified individuals are authorized to replace the ASB battery.

**WARNING! Do not look at the light beam for an extended period: the optical radiation may harm your eyes.**

### FIRST USE

- Remove the protective transparent film covering the LED panel.
- Install ASB into your Les Jardins lamp
- This product is delivered ready for use, with batteries at 25% of their full charge.
- Stable performance after one week.

## INSIDE PANEL

1 / SOLAR PANEL

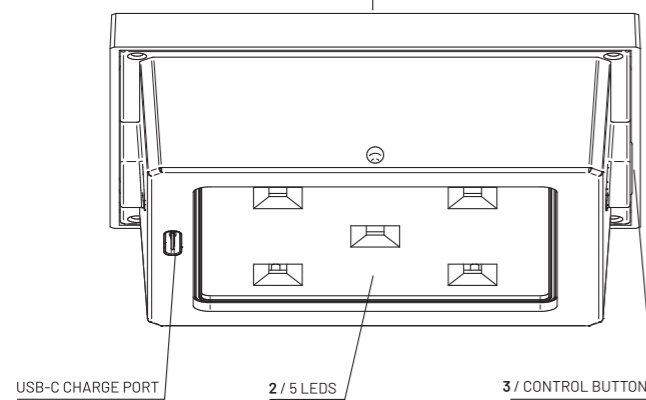

USB-C cable provided

#### 1 / SOLAR PANEL

Monocrystalline : 10 cells  
1.8 watts  
ETFE coating for greater durability:  
- Operating temperature up to a constant 150°C.  
- Extremely solid fluoropolymer resin.  
- Mechanically resilient coating.

#### 2 / LED TECHNOLOGY

High power LED: 300 LUMENS  
Color temperature: 2700K (warm white)

#### 3 / CONTROL BUTTON

\*See operating instructions.

#### ASB HOUSING

Made of ABS, shock resistant, light, and rigid.  
Anti-UV treated.  
One 2.6 Ah lithium battery replaceable,  
lifespan of 4 to 6 years.

### OPERATING INSTRUCTIONS

#### ONE BUTTON ONLY FOR THE 2 OPERATION MODES

- 1 - **SMART MODE**, automatic intensity adjustment.
- 2 - **FORCED ON MODE**, adjustable from 3 to 300 lumens.

#### FIRST SHORT CLICK ON CONTROL BUTTON = MODE 1 - SMART MODE = VISUALIZED BY ONE FLASH

ASB switches on automatically at nightfall. It knows both how much energy it has and how many hours it must provide light for. It adapts its intensity to remain active all night, with greater power generated at the beginning and end of the night. It switches off automatically at sunrise.

- The ASB automatically optimizes its brightness according to its power reserve, your location and climate. Allow one week for the ASB to learn its environment.
- Our system constantly monitors three parameters: power input, power reserve, and dark time. Brightness is adjusted in such a way that the light can stay on all night.

To lock this mode: First enable SMART MODE as instructed above. Then press and hold the control button for 10 seconds until the LEDs flash rapidly. SMART MODE is now locked.

To unlock this mode: press and hold the control button until the LEDs flash rapidly for 10 seconds. SMART MODE is now unlocked. SMART MODE will still be enabled until another mode is selected.

#### SECOND SHORT CLICK ON CONTROL BUTTON = MODE 2 - FORCED ON MODE = VISUALIZED BY TWO FLASHES (Adjustable from 3 to 300 lumens)

The ASB switches on at a pre-set level of 300 lumens, with 4h00 of lighting autonomy when fully charged.

**DIMMING INFORMATION:** pauses at 75 and 150 lm (when setting level of brightness, the ASB pauses at these levels before continuing after 0.5 s). Press and hold the control button to change the settings. To reverse the direction of the power level, take your finger off the control button, then press and hold again.

#### THIRD SHORT CLICK ON THE CONTROL BUTTON = OFF

### USEFUL INFORMATION

When the ASB flashes (rapidly three times every 10 seconds), it means that the battery is more than 75% charged.

If the battery is completely empty, the ASB will switch itself back on at the last recorded setting as soon as it has sufficient charge.

For optimum use, do not cover the solar panel.

### TECHNICAL FEATURES

#### BATTERY LIFE

4H00 AT 300 LUMENS  
8H30 AT 150 LUMENS  
17H00 AT 75 LUMENS

#### TIPS AND SPECIAL FEATURES

- SOLAR CHARGE: 8 hours in optimal conditions.
- While charging, 3 short flashes every 10 seconds show that the battery is 75% full.
- USB charge: 4 hours
- Shorts flashes every 10 seconds show the state of charge:
  - 1 flash 25% or below
  - 2 flashes 25% up to 75%
  - 3 flashes 75% or above

#### BATTERY

- One 2.6 Ah lithium-ion battery (replaceable through our after-sales service).
- Lifespan of 4 to 6 years.

