



USER MANUAL

GLASS DOOR LOCK



Fingerprint



Password



tuya App



RFID Card



Remote Control
(Optional)



INDEX

<u>Introduction</u>	1-2
<u>Technical Specification</u>	3
<u>Lock Structure</u>	4
<u>Product Features & Packing Details</u>	5
<u>Installation Steps</u>	6-8
<u>Operation Steps</u>	9-10
<u>FAQ</u>	11
<u>Warranty Card</u>	12-13













INTRODUCTION

CAUTION

- Necessary safety measures must be ensured before starting the installation to prevent damage to assets and personnel.
- Accuracy of the door preparation is a critical parameter for the proper door installation, Lock functioning, and security of the product.
- Any deviation from the given specs and misalignments etc., can cause performance and security breaches.
- The product images shown in this document are for reference & representation purposes only & the actual product may differ from these.
- Check for leveling & alignment of doors before installation of the product.

The image contained in this manual is a reference used for description and instruction, and its types and colors may differ following the product model.

Safety cautions

-  **Do not directly spray water when cleaning the product.**
Water coming through into the product causes malfunction or abnormal operation.
-  **Do not dismantle the product yourself. It may cause malfunction of product.**
If you dismantle the product yourself, the product may not function as it should.
-  **Do not place inflammable such as gas lighter near the product.**
It may cause malfunction or abnormal operation.
-  **Completely block holes on door after product installation.**
There is a risk of intrusion through door holes.
-  **Do not use the product at places exposed to water.**
Since the product does not have water and dust proof structure, it may cause product malfunction due to short circuit.
-  **Do not use the product in place with direct sunlight or high temperature.**
It may cause malfunction or abnormal operation.
-  **Do not install the product at place where water, snow or rain can come through.**
It may cause malfunction or abnormal operation.
-  **Do not impact on or alter the product.**
It may cause malfunction or abnormal operation.
-  **Replace all batteries with new one when changing batteries.**
If old batteries are used with new ones, product life span cannot be guaranteed
-  **Use alkaline battery only.**
Using rechargeable battery may cause product malfunction.

Caution

Since the product is a keyless door lock, a part of the door lock may get damaged in case of malfunction. Therefore, the user needs to be familiar with the manual closing and opening of the device in an emergency.

1. Voltage: DC6V
2. Be cautious that reverse installation of batteries may cause liquid leakage or a burst.
3. When the battery is discharged, replace all batteries and DO NOT use used batteries with a new one.
4. Sensor operation temperature: 60°C (+10°C).



INTRODUCTION

CAUTION

Special Note Before Installation

- Necessary safety measures must be ensured before starting the installation to prevent damage to assets and personnel.
- Accuracy of the door preparation is a critical parameter for the proper door installation, Lock functioning, and security of the product.
- Any deviation from the given specs and misalignments etc., can cause performance and security breaches.
- The product images shown in this document are for reference & representation purposes only & the actual product may differ from these.
- Check for leveling & alignment of doors before installation of the product.

Do's

- Admin/Master should always be used by the primary owner of the house and can be activated or deactivated by him only.
- Always change the default factory password in the applicable models immediately after the installation is complete.
- Inserting batteries in the wrong direction or wrong polarity in the battery compartment may lead to fluid tears or ruptures, so always make sure you insert the batteries as per the correct polarity, which matches the product's polarity (+/-).
- Always keep the Master Passcode safe, and in the case of forgotten Master Passcode, please get in touch with our helpline number for further assistance.
- Always use a soft and dry cloth to clean the product.
- Replace all old batteries with a new ones when changing batteries. Using old batteries in combination with the new ones can cause the product to malfunction.
- Use Alkaline batteries only.
- Using rechargeable batteries may cause product malfunction.

Don't's

- Do not Dismantle the product by yourself. Always take the help of the certified service technician for dismantling the product as improper handling may cause damage to the product resulting in malfunctioning of it.
- Do not insert batteries with reversed polarities. Always check and ensure proper polarity of batteries in line with Product Polarity while inserting it into the product as any mismatch can result in liquid leakage or rupture.
- Do not install, disassemble or repair the product without the help of a certified service technician.
- Do not give excessive impact force on the product.
- Do not directly spray water when cleaning the product. Water coming through into the product causes malfunction or abnormal operation.
- Do not install the product in an area exposed to the external environment.
- Do not let dew condensation enter the product as it may cause product malfunction if a certain level of moisture enters into it, so make sure to remove any source of dew condensation through periodic ventilation or paper weather stripping.

User Instruction

- Please read all the safety & operating instructions before the product installation.
- To ensure continuous access security, change your PIN code regularly.
- Only use new batteries & beware of potential battery leakage, which may cause damage/malfunction to the product.
- Replace all batteries when prompted by the automatic low battery indication and do not re-use any of the batteries.
- Installation must be done by an iLockey service professional.
- Disassembly or attempted repair, rework or reverse engineering is prohibited without written consent & approval of iLockey except for the normal installation of the product by a designated service professional.
- Clean the product only with a dry microfiber cloth.
- Do not insert or press any of the buttons with Pin or sharp objects.
- This product has not been tested for external use. Avoid any contact with water.
- This product was designed for use in weather-protected outdoor and indoor areas and domestic application only.
- Do not expose the product to strong shocks or vibration.
- Keep the filled-out warranty certificate and invoice, as it is required for processing all warranty requests.
- The information in this user guide is subject to change without notice.

This product must be installed by an iLockey professional. In case of defects resulting from installation by other than an iLockey professional, the Product warranty will be void. iLockey reserves the right to charge on out-of-warranty products.



Technical Specification

Fingerprint Speed	≤ 0.3S
Working Voltage	4 pcs (1.5V "AA") alkaline batteries
Misidentification Rate	≤ 0.0001%
Opening Method	Left and right interchange
Lock Material	Zinc alloy/ABS
Fingerprint Capacity	200 Pcs
Display Size	0.96 inch
Static power consumption	Less than 10ua
Unlock Way	Fingerprint, RFID Card, Passw Tuya App, Remote Control (Optional)
Unlock Time	1-1.5 Seconds
Working Temperature	-20° - 50°
Working Humidity	10% - 95%
Factory Passcode	Factory Master Password : 123456 a configuration, it will be invalid
Product Color	Black
Suitable door thickness	8-12mm
Administrator capacity	9
User Capacity	PWD+ RFID card (1000)Pcs
Door Application	Glass Door Lock
Product Weight	2.2kg
Remote Capacity	50 pcs



Lock Structure

1. Display
2. Keypad & RFID Card
3. Fingerprint
4. Battery Cover
5. Mechanical Knob
6. Emergency Power Supply
7. Door Bell

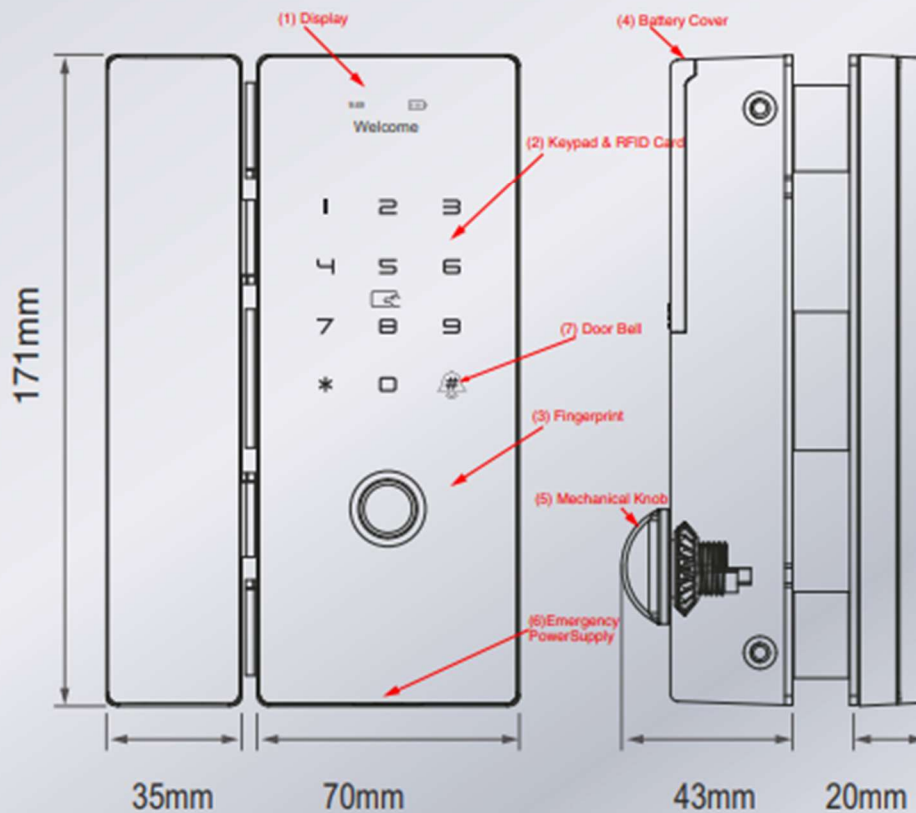



PRODUCT FEATURES

- 1) Micro USB emergency power supply: In case of emergency the product could be operated by USB through power bank.
- 2) Fingerprint: use registered fingerprint to open the lock.
- 3) Digital keypad/RFID card indication area: use registered password or RFID card to open the lock.
- 4) Reset button: use reset button for factory setting or initialization settings.
- 5) Smart freeze & auto secure: more than 5 times wrong password in 5 minutes, the keypad will be locked for 90sec, the lock will not respond to any operation within the 90 seconds.
- 6) Anti-theft password; enter the password as follows when opening the door: XXX password XXX. you can add some irrelevant digits before and after the password, and then press # to confirm. the actual password must be included.
- 7) Door bell: when lights on can be used as #, lights off can be used as a bell.
- 8) Passage Mode: when you need to open/close the doors frequently.
- 9) Low battery alarm: when the voltage is lower than 4.8V, the alarm is activated each time the lock is unlocked. the lock could be unlocked 100 times, after the first alarm.
- 10) Access records query: you can check access records anytime in Ozolife app.

10. Packing Details

Name	QTY
Front Panel	1pc
Rear Panel	1pcs
User Manual	1pcs
RFID card	2pc
Opposite Pull Screw	4pc
Mounting Plate	2pcs
Strike plate(Glass to Wall)	1pcs
Strike box(Glass to Glass)	1pcs
M4 screws(Glass to Glass)	8pcs



The reversing method of frameless glass door

Remove the 4 fixing screws on the front panel, rotate the U-shaped bracket by 180°, and then tighten the 4 screws.

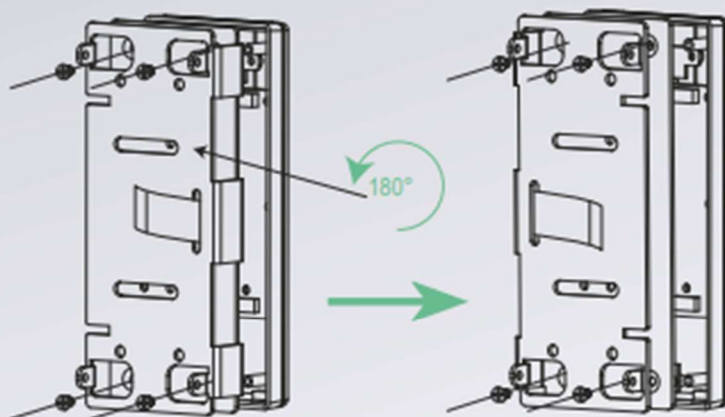

Frameless glass door installation

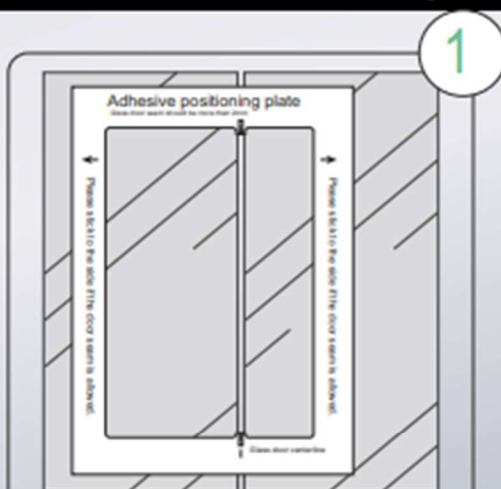

After cleaning the glass, attach the fixing template of adhesive plate to the door (door seam is aligned with door seam line of template door)

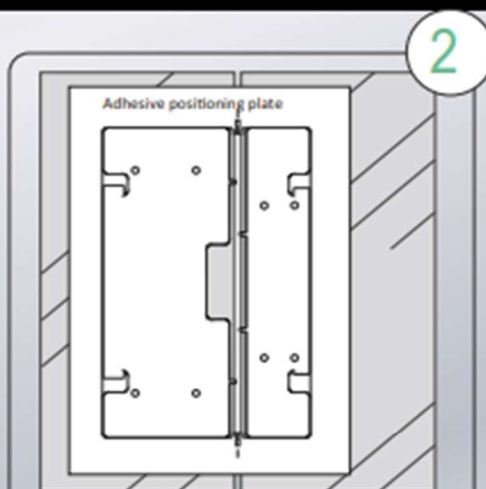

Remove the adhesive tape from the adhesive plate, and attach it to the middle blank and press it tightly (the small feet of the adhesive plate are close to the door tightly)

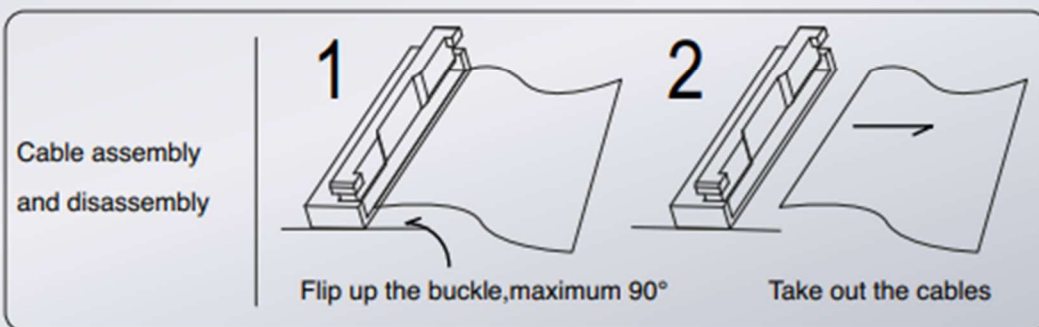
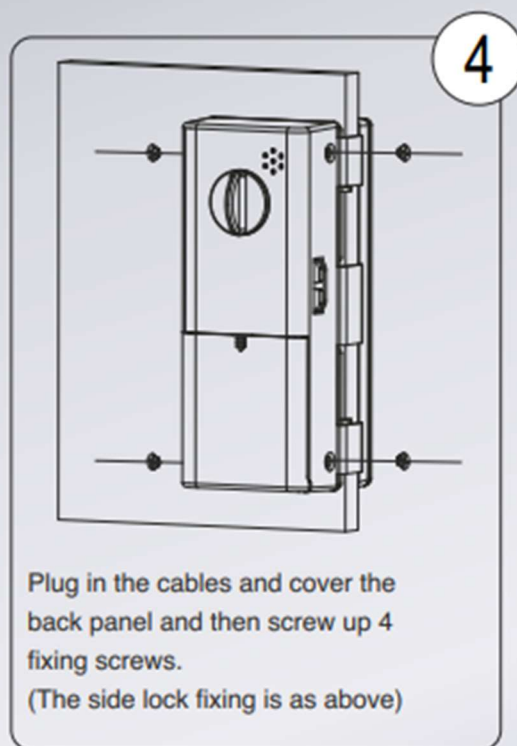
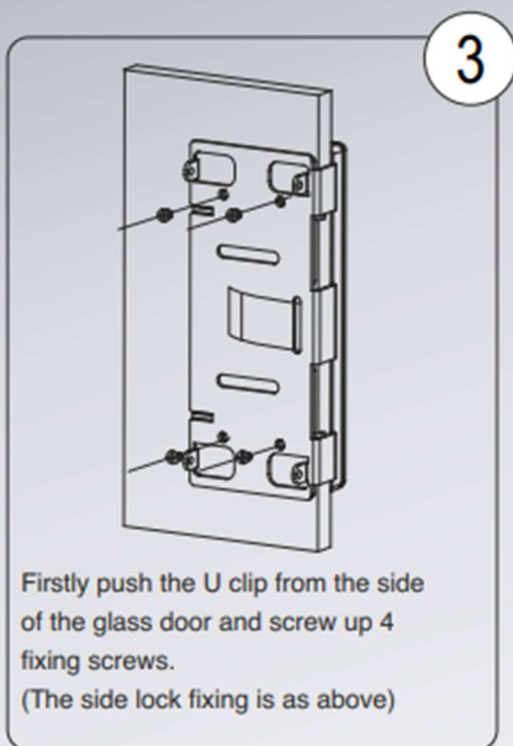

Note:

1. The template must be used for the position fixed plate. The door joint should not be less than or equal to 4 mm.
2. The thickness of the glass is 10-12 mm.



The installation of single opening (blade)

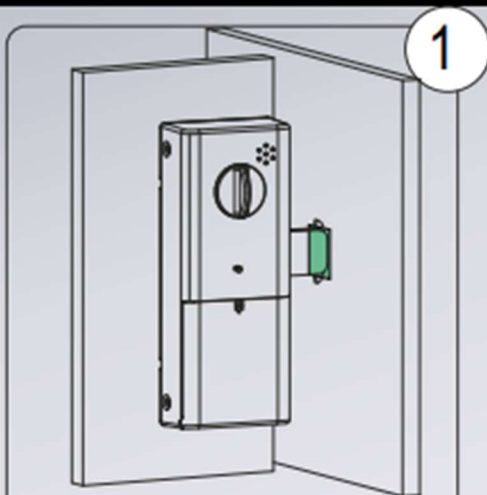

1
Install the main lock (installation method is the same as above), and then unscrew the lock tongue to mark it when the door is closed naturally.

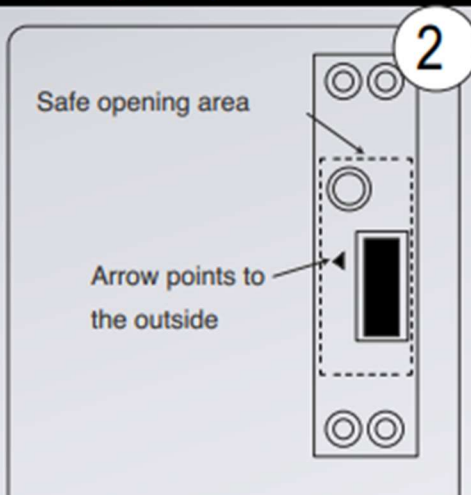

2
Safe opening area
Arrow points to the outside
Note: When the blade is installed, its triangle direction must point to the outside (the hole should be opened according to the size of opening drawing)

Installation of framed door with holes such as wooden doors and aluminum alloys doors.

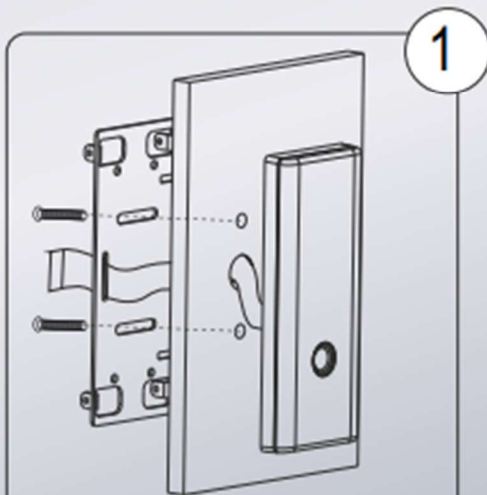

1
According to the size requirements, please open holes on the door and fix the main lock through cables and screws, and finally fix the back panel by screws.

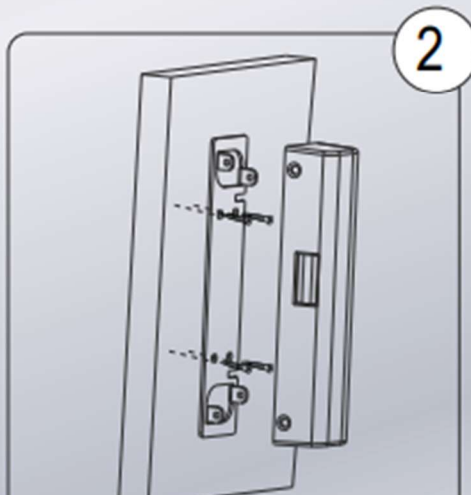

2
The side lock should be fixed directly with self tapping screws or rivet and also the back panel should be fixed with screws.



How To Pair The Lock With Tuya smart App: ADD LOCK

- 1 Search Tuya smart app from the App store and register.
- 2 Open App and access it and follow below way add lock (Auto connection/add manually)
Auto connection.

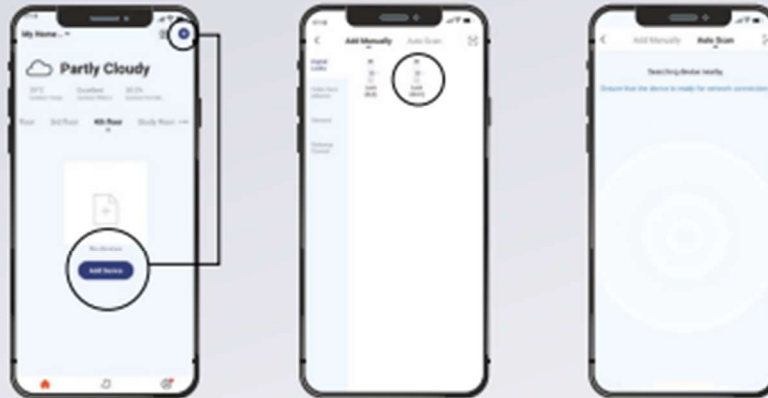

3 Add Manually



- 4 Wake-up the keypad then press # then enter registered admin (password) with # or fingerprint or RFID card. then press 2 for "System setting" then press 3 for "RF device" then press 1 for "RF device ON"



ADD TEMPORARY CODE SETTING

- 1 After adding temporary code, need to try on lock then finished.
- 2 Max. Support 10 groups of code, and code can be edited or deleted.
- 3 Temporary codes can be settled down by period.

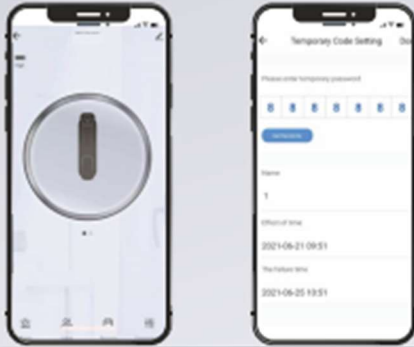

- 5 Remote unlocking: Press bell icon when keypad is off then unlock the door through tuya app

How To Add Remote Control (Optional)

Wake-up the keypad then press # then press 1 for "Manage user" then press 1 for "Add user" then press 1 for "Add admin" and also press remote lock button for adding remote

How To Operate Lock:

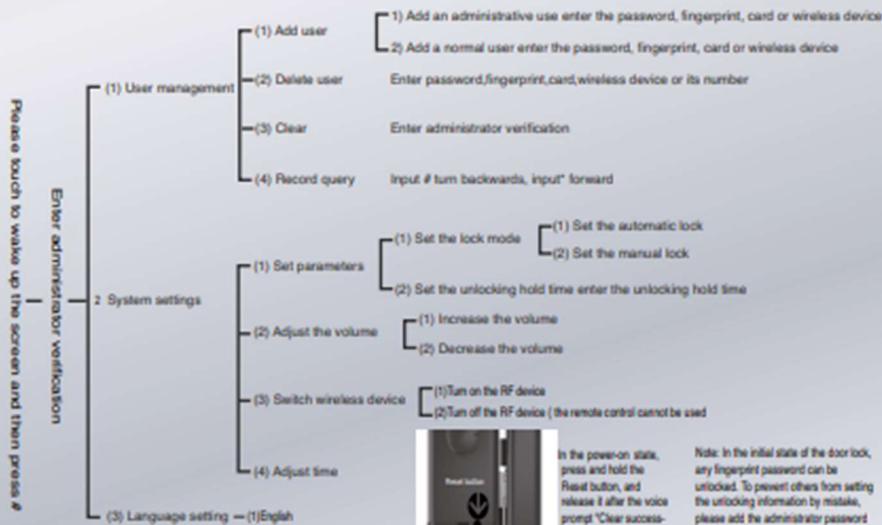



FAQs

- 1 How to read operation records?**
Select "Opening record" option on lock main interface

- 2 After installation, touch sensing keyboard or screen not responding.**
 - a) First check that the positive and negative electrodes of the battery have been installed upside down.
 - b) Check whether the battery has enough power.
 - c) Remove the back panel body and see if it's connected with the front panel.
 - d) Remove the lock and check whether the connecting wires of lock body are not squeezed or twisted.

- 3 Unable to register fingerprint.**
 - a) Check the fingers for dirt or wear. Also check the fingerprint sensor on the lock for dirt and oil stains, etc.
 - b) Check if the fingerprint sensor is working properly (Press any fingerprint on sensor to see if there is any response).

- 4 Why is the smart lock consuming power faster than usual?**
 - a) Large standby power consumption.
 - b) Short circuit.

- 5 After how many incorrect password attempts will the lock go in auto secure mode?
For how long it will be in auto secure mode?**
Every time you enter a wrong password more than 5 times in a row, the keyboard is locked for 90 seconds.