



2023 CATALOGUE

# VANTAINER<sup>®</sup>

TOUGH TRANSPORT SYSTEMS

REMOVABLE, LIGHTWEIGHT VAN RACKING SYSTEM

[WWW.VANTAINER.COM](http://WWW.VANTAINER.COM)

# CONTENTS

WHY CHOOSE US



P3

FLEET SERVICES



P4

VAN RACKING



P6

SYSTAINER® T-LOC



P14

## ABOUT US VANTAINER®

VanTainer Ltd® is the Worldwide manufacturer of the very clever Mobil Van Racking System. In addition Vantainer is the UK Distributor for Tanos GmbH who manufacture the world renowned Systainer® Box System.

With over 50 years' experience in the Tool Industry, we understand the user's needs in delivering products that improve the working environment while increasing productivity and efficiency.

"We aim to deliver the best solution for transporting and moving tools and equipment that meets our customer's expectations and satisfies their needs."



WHY CHOOSE US



## WHY CHOOSE VANTAINER®

The VanTainer racking system aims to save users weight, time and space. Fleets are benefiting with reduced vehicle running costs improved cargo stock management and operator efficiency. The innovatively designed stacking systainer® system helps locate tools, consumables and equipment faster.





## AT VANTAINER WE THINK INSIDE THE VAN ...

Vantainer Fleet business has been launched to provide the next generation, lightweight, removable van racking Mobil System for commercial vehicles.

Vantainer is looking to expand its network of Converters to help increase its market share. With over 20 years of experience with Fleet Management specialists. Vantainer has a proven track record in installing time, cost and weight saving Van Racking Systems.



## WE OFFER

A personal consultation with your management team to understand your needs and meet your expectations.

A dedicated Mobil Installation trailer and team that can completely install at your premises or any location in the UK.

A secure compound at our location in Kent, where we can fit out your vans.

# VAN RACKING

## SYSTEM BENEFITS

- ✓ Fast and easy installation and removal
- ✓ Light weight
- ✓ High stability
- ✓ Flexible, adaptable design to fit any new vehicle upgrade or special cargo
- ✓ High durability: can be used for several generations of vehicles
- ✓ Increases vehicle organisation, saving time and money
- ✓ Flexible and variable storage possibilities. Suitable with the Vantainer systainer® T-Loc range, systainer® Classic range and Makita, DeWalt, Bosch and Festool boxes.
- ✓ Safety: DERKA certified crash test

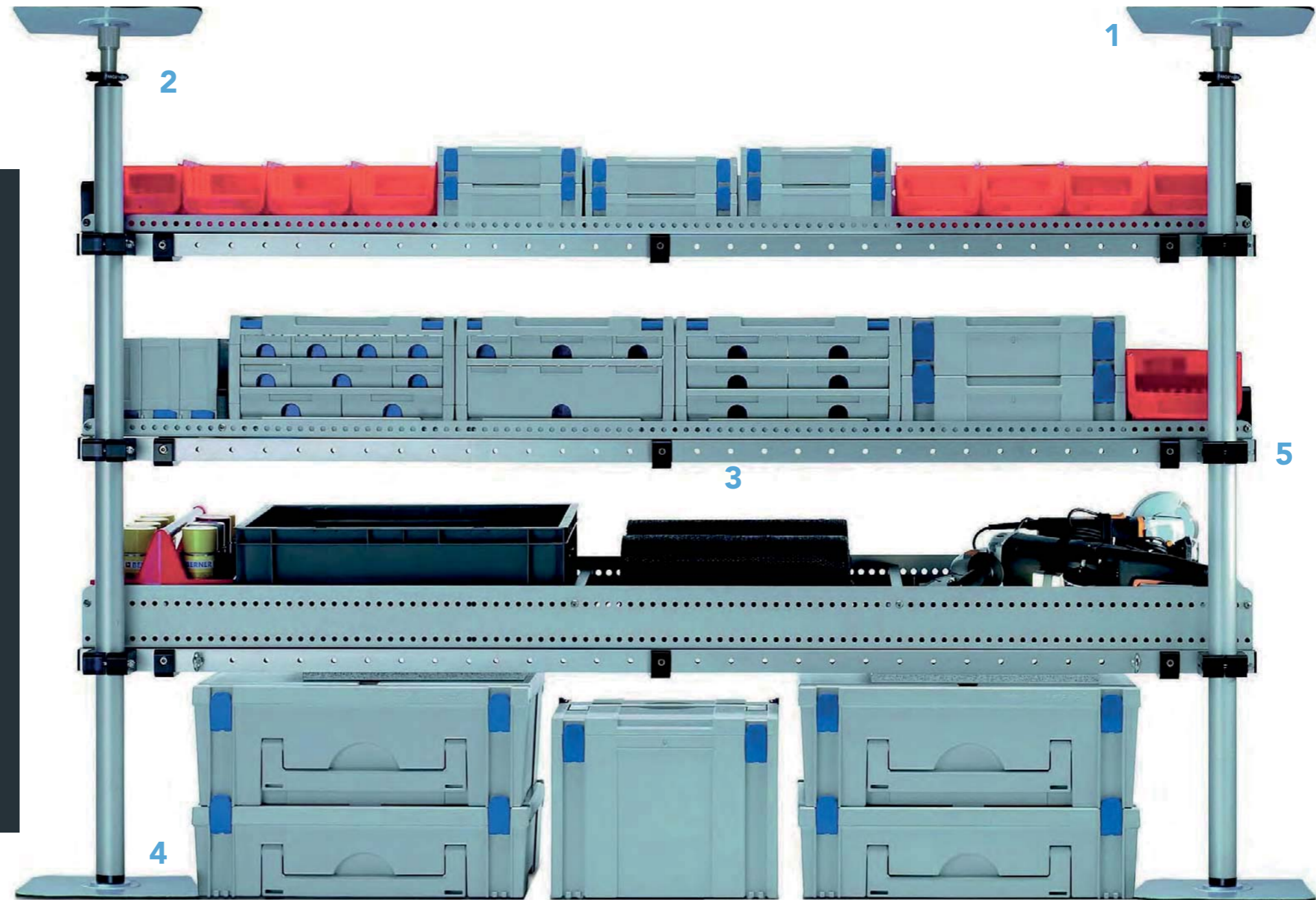

**1.** Self-adhesive fleece, velcro mat with an adaptor, spacer tube and adaptor unit



**2.** Quick release for adjustment without any tools



**3.** Different depths and widths are available and inclination is possible



**4.** Self-adhesive fleece and velcro mat with an adaptor. A floor plug-in part and spacer tube support the system



**5.** Height adjuster bracket for quick release for rapid removal and installation



Vantainer manufacture 90% of all the Van racking components in the UK.

The Systainer® range of boxes are manufactured in Germany.

# SMALL. MEDIUM. LARGE.

All self-assembly racking kits come ready to fit. We provide adaptable van racking for all vehicle types. The kits are divided into three categories depending on your vehicle size. Please find your vehicle model below to specify your kit size.

MAKE	MODEL	MINI KITS	MIDI KITS	MAXI KITS
	Nemo	X		
	Berlingo	X		
	Dispatch		X	
	Relay			X
	Doblo	X		
	Florino	X		
	Scudo		X	
	Talento		X	
	Ducato			X
	Connect	X		
	Courier	X		
	Fiesta	X		
	Custom		X	
	Transit			X
	NV200/ NV300/ Primaster		X	
	NV400			X
	Bipper	X		
	Partner	X		
	Expert		X	
	Boxer			X
	Kangoo	X		
	Trafic		X	
	Master			X
	Astra	X		
	Vivaro		X	
	Movano			X
	Caddy	X		
	Sporter		X	
	Crafter			X

\*\*\* Please note not all vehicle models are listed above. Please select the closest vehicle to your model size.

## MINI KITS



VAN RACKING



PRODUCT	SKU	D mm	W mm
<b>MINI KIT: One shelf</b> <i>1 x shelf unit</i>	80595101	310	1260
<b>MINI "L" KIT: One L-shaped shelf</b> <i>2 x shelf units</i>	80595301	310	1260
<i>Maximum load capacity</i>	120 kg 150 kg 50 kg	<i>Without brace support With brace support Per shelf</i>	

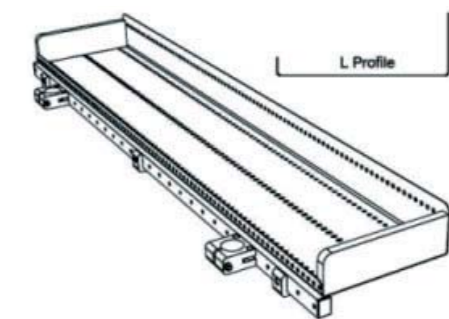
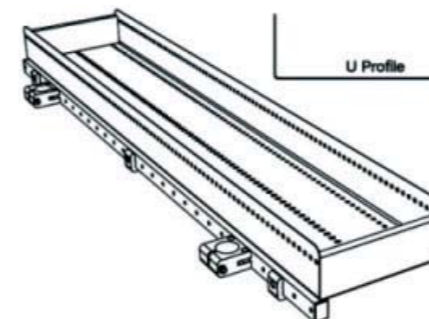

# MIDI KITS



PRODUCT	SKU	D mm	W mm
<b>MIDI KIT: One shelf</b> 1 x shelf unit	80595102	310	1670
<b>MIDI KIT: Two shelf</b> 2 x shelf units	80595202	310	1670
<b>MIDI "L" KIT: One L-shaped shelf</b> 1 x shelf unit 1 x shelf unit	80595302	310 310	1670 1260
<b>MIDI "L" KIT: Two L-shaped shelves</b> 2 x shelf units 2 x shelf units	80595401	310 310	1670 1260
Maximum load capacity	120 kg 150 kg 50 kg	Without brace support With brace support Per shelf	

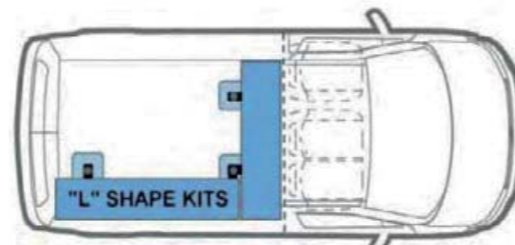
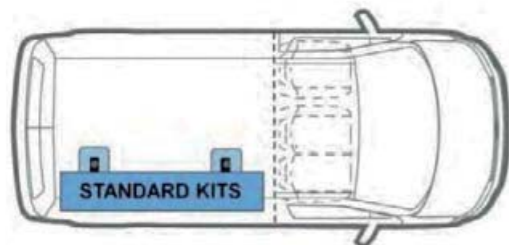

# MAXI KITS



PRODUCT	SKU	D mm	W mm
<b>MAXI KIT: One shelf</b> 1 x shelf unit	80595103	310	2070
<b>MAXI KIT: Two shelf</b> 2 x shelf units	80595203	310	2070
<b>MAXI "L" KIT: One L-shaped shelf</b> 1 x shelf unit 1 x shelf unit	80595303	310 310	2070 1260
<b>MAXI "L" KIT: Two L-shaped shelves</b> 2 x shelf units 2 x shelf units	80595402	310 310	2070 1260
Maximum load capacity	120 kg 150 kg 50 kg	Without brace support With brace support Per shelf	

VAN RACKING



**AFTER**



**BEFORE**



**VAN RACKING**





# SYSTAINER® T-LOC

The Systainer® T-Loc range allows individual systainer® boxes to be stacked systematically on top of one another and to be locked together using the innovative T-Loc feature. This feature also enables any box in the stack to be accessed whilst still being locked together. This gives you a linked systainer® tower which is arranged in order to save you valuable space and time.

*\* Compatible with the Classis Systainer® range, Makita, DeWalt, Bosch and Festool.*

SYSTAINER® T-LOC

## PACKAGING & STORING

- ✓ Systainers come in a range of sizes to suit the majority of your needs
- ✓ Linking the individual systainers can help with organisation
- ✓ Foam inserts protect valuable items from getting damaged during transportation

## ORGANISING

- ✓ Quickly identify what you need by using our range of labels
- ✓ The systainer® system can be tailored to your trade or profession so you optimise your efficiency
- ✓ A range of inserts and foams allows you to adapt to a range of applications



## PRESENTING

- ✓ A more professional approach to deliver better results
- ✓ Create the right impression with your customers and your products
- ✓ Custom branding labels tailor the box to your brand

## TRANSPORTING

- ✓ The linkable feature connects the systainers together, making it easier and quicker to move in one go
- ✓ Made with ABS plastic to ensure the systainer® is durable.



## FEATURES



### STANDARDISED TO EURO PALLET DIMENSIONS

The dimensions of the systainer maximises the volume capacity of the standardised euro pallet dimension.

### INDIVIDUAL

Our standardised colour is an anthracite box, handle and catch. For large orders you can design your systainer® by choosing different colour variants for the box, catch and handle.

### ABS PLASTIC

The systainer® is designed to provide maximum strength using ABS plastic, a prime based material. This rugged structure ensures all systainer® boxes are impact resistant.

### CONSERVATION OF VALUE

Replace instead of throwing away! The innovative systainer® system is designed so that all the components can be replaced to maintain its durable quality.

### STACKABLE AND LINKABLE

The individual cases can be stacked and securely linked. Each case can be used and accessed individually and simultaneously.



# TAILORED TO YOU



## POLYURETHANE LABELS

UV stable, weather and oil resistant, with a permanent adhesive back. Enhance your brand by customising the domed label with your logo.

Colour options:

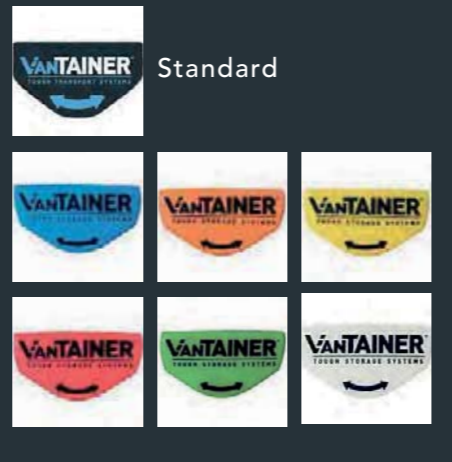

## CONTENT ID LABELS

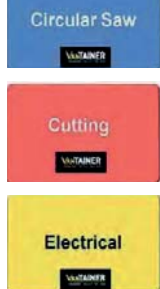

A range of polyurethane labels in different colours and various identifications which enable you to quickly identify your systainer® contents. Self adhesive they simply attach to your systainer cases.

## LABELLING SET FOR SYSTAINER T-LOC I-V

Consisting of 20 transparent plug-in cards and 2 labelling sheets with 10 paper cards each.



SYSTAINER® T-LOC

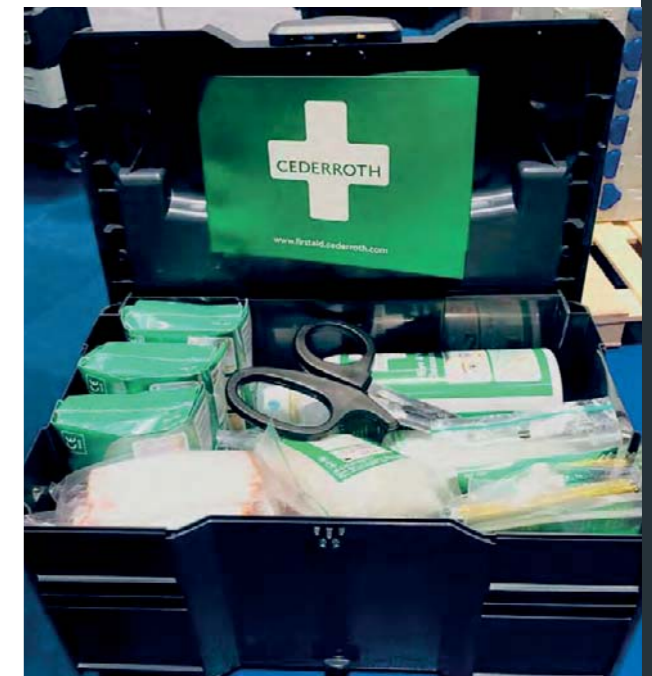



THINKING INSIDE THE VAN



Follow @vantainer on Facebook and Instagram for updates and offers

**Vantainer Ltd.**

Greenbox Storage Center  
College Road  
Swanley  
Kent  
BR8 7LT  
United Kingdom

**Tel: 0203 6918833**

**Sales enquiries: [sales@vantainer.com](mailto:sales@vantainer.com)**

[www.vantainer.com](http://www.vantainer.com)