



514 W 21st Street, Newton, NC 28658  
(828) 459-1980

Find us on:

[WWW.SUNDOWNAUDIO.COM](http://WWW.SUNDOWNAUDIO.COM)



### Mono Blocks:

- |           |            |
|-----------|------------|
| SFB 600D  | SFB 5000D  |
| SFB 1000D | SFB 8000D  |
| SFB 1500D | SFB 13500D |
| SIA-1250D | SFB 3000D  |
| SFB 2000D | SIA-1750D  |
| SIA-2500D | SIA-3500D  |
| SIA-5000D |            |

### Multi - Channel

- |            |             |
|------------|-------------|
| SFB 200.4D | SFB 1000.4D |
| SFB 500.4D | SFB 1800.5D |

## DIGITAL MONOBLOCK FEATURES

- Digital Class-D Mono Block Amplifier
- Dual MOS-FET PWM Power Supply
- 1 Ohm Stable Load
- 12 dB/Octave - Variable Low Pass Filter
- 0 to 12dB - Variable Bass Boost
- 4 Way Protection Circuit (Thermal, Voltage Speaker short and DC Offset)
- Wired Remote Control with Clipping Indicator.

## DIGITAL MONOBLOCK SPECIFICATIONS

Tested @14.4Volts	SFB-600D	SFB-1000D	SFB-1500D	SFB-2000D	SFB-3000D	SFB-5000D	SFB-8000D	SFB-13500D
1Ω Mono RMS	600W	1000W	1500W	2000W	3000W	5000W	8000W	13500W
2Ω Mono RMS	350W	850W	1200W	1500W	2000W	3200W	5000W	8100W
4Ω Mono RMS	250W	500W	650W	950W	1100W	2200W	3250W	5500W
Recommended Fuse Rating	60A	100A	140A	180A	250A	220A x2	350A x2	400A x3
LoW Pass Filter (-12dB/8) Variable	80HZ - 20kHz							
High Pass Filter (-12dB/8) Variable	15 - 1kHz				15 - 80Hz			
LEVEL (Bass Boost)	0 - 12dB (50Hz)							
Input Sensitivity	5V Max							
Signal Noise Ratio	86dB	100dB	100dB	100dB	86dB	100dB	100dB	100dB
Working Voltage	10.5V - 15.5V DC							
Width mm	185mm	185mm	185mm	185mm	225mm	225mm	225mm	225mm
Length mm	95mm	115mm	145mm	165mm	185mm	265mm	390mm	492mm
Height mm	62mm	62mm	62mm	62mm	68.5mm	68.5mm	68.5mm	68.5mm
Width inches	7.28"	7.28"	7.28"	7.28"	8.86"	8.86"	8.86"	8.86"
Length inches	3.74"	4.53"	5.71"	6.50"	7.28"	10.43"	15.35"	19.37"
Height inches	2.44"	2.44"	2.44"	2.44"	2.70"	2.70"	2.70"	2.70"

## TROUBLESHOOTING

All Sundown Audio amplifiers have multi-layer protection features to prevent damage from misuse or faulty conditions to ensure long lasting life of your investment. If the unit senses excessive heat, short circuited speakers, overload, or voltage fluctuation outside of the working range the protection indicator light will turn red and the unit will turn off. In order to solve this problem, you should turn all levels down, power off the unit, then carefully check the installation for wiring mistakes or shorts. If the amplifier is excessively warm the protection light will not turn on as the unit will turn off to protect itself from overheating. Let the unit cool down for 30 minutes and try again. If the unit works, try moving the amplifier or make sure nothing is covering it so it can vent heat off of the heatsink. Before you remove or uninstall the amplifier, refer to the list below for suggested solutions.

### Amplifier Doesn't Turn On or No Output

- Check the fuse(s), not just visually, but with a continuity meter and all 12+ volt, remote and ground connection. Make sure you have 13+ volts. It is possible for a fuse to have poor internal connections, take the fuse out of the holder for the testing.
- Check the input signal from the source unit using an AC voltmeter to measure the voltage while it's being played. The voltage should be from 0.2 to 6.0 volts from the RCA cables.
- Check the output of the amplifier, test for output at the speaker outputs of the amplifier.
- Check to ensure that the speaker wires are making a good connection to the amplifier and the subwoofers.

### Amplifier Goes Into Protection

- Check shorts on speaker wires or open coil.
- Check input voltage from RCA, if DC signal is over 4 volts, the amplifier will go into protect. Remove and reset the power to the unit to check if it will turn on.
- Check impedance to make sure it's over the minimum load, see the specification charts in this manual for the minimums of your specific amp.
- Check input voltage. The amplifiers covered in this manual have a working range of 10.5 to 15.5 volts.
- Check chassis ground and remote using same ground.

### Distorted / Attenuated / Noise Sound

- Check the chassis ground connections of all audio equipment.
- Check amplifier controls for errors, input level or crossover setting.
- Check the speaker wires for a possible short, either between the positive and negative leads or between a speaker lead and the vehicle's chassis ground.
- Check the nominal load impedance to verify that the amplifier is driving a load equal to or greater than the specified minimums, see the specification charts in this manual for the minimums of your specific amp.
- Check the input signal and input signal cables to make sure signal is present at the amplifier inputs and the cables are not pinched or loose. It may be helpful to try a different set of cables and / or a different signal source to be sure.
- Check speaker wiring for reverse polarity.
- If you hear a pulsing sound from your speakers, it means that there is something being overdriven. This could be due to a gain being set too high or a speaker impedance being too low, see the specification charts in this manual for the minimums of your specific amp.

## WARRANTY

Your new Sundown Audio amplifier is covered by a 2-Year limited warranty if purchased from an authorized Sundown Audio dealer. This warranty does not cover improper installation, accidental damage, misuse, abuse, improper wiring, operation of unit outside of listed specifications, or any product that has been modified or repaired by anyone other than Sundown Audio. Your warranty covers defects in materials and/or workmanship ONLY and is not an insurance policy. The warranty only covers the original owner of the amplifier.

All warranty returns must be accompanied by the original sales invoice or receipt. You must contact us to request an RMA number prior to sending any returns via the RMA request form on our web-site. During the RMA number process, we will generate a pre-paid FedEx label for your return. If your amplifier is covered under warranty shipping both ways will be at no cost to you – if your amplifier is replaced/repared outside of warranty or if no defect is found and your product must be return to you shipping both ways will be billed to you.

At the sole discretion of Sundown Audio your amplifier will be either repaired or replaced when it is being covered under warranty. In the event of shipping damage due to improper packaging on products being returned to Sundown Audio the customer is liable for the cost of all damages, necessary repairs, or replacement. Be sure to properly pack your return!

Sundown Audio also offers a 5-Year “discounted replacement” policy on all of our amplifiers. We are so certain of the quality of our equipment that even if you are at fault for causing damage to your amplifier we will offer you a new unit at a reduced cost for a full 5-years from your purchase date. Contact us via our RMA form to take advantage of this offer. This offer applies only to the original purchaser of the unit and is not transferable. As is the case with standard warranty claims the return must be sent with a copy of the original invoice or receipt.

In no event will Sundown Audio be liable for incidental, consequential, or other damages resulting from the use of this product, this includes but is not limited to, damage of hearing, property or person, damage based upon inconvenience or on loss of use of the product, and to the extent permitted by law, damages for personal injury. This warranty gives you specific legal rights, and you may have other rights, which vary from state to state. This warranty applies only to products sold and used in the United States of America. In all other countries please contact your local distributor.

## FULL RANGE DIGITAL FEATURES

- High Efficiency Digital Multi-Channel Design
- 12dB/Octave-Variable High Pass Filter
- 12dB/Octave-Variable Low Pass Filter
- Clipping Indicator
- 4 Way Protection Circuit (Thermal, Voltage Speaker short and DC Offset)
- Optional Wired Remote Control with Clipping Indicator.

## FULL RANGE DIGITAL SPECIFICATIONS

Tested @14.4Volts	SFB-200.4D	SFB-500.4D	SFB-1000.4D	SFB-1800.5D
1Ω RMS	200W	500W	1000W	1Ω NOT SUPPORTED (CH1-4) 1000W (CH5)
2Ω RMS	125W	300W	550W	300W (CH1-4) 500W (CH5)
4Ω RMS	75W	200W	325W	200W (CH1-4) 250W (CH5)
Recommended Fuse Rating	80A	180A	350A	150A
Low Pass Filter (-12dB/8) Variable	50Hz - 6kHz		50Hz - 6kHz 50hz - 20kHz (CH5)	
High Pass Filter (-12dB/8) Variable	15Hz - 6kHz		15Hz - 6kHz 15hz - 1kHz (CH5)	
LEVEL (Bass Boost)	0 - 12dB (50Hz)			
Input Sensitivity	5V Max			
Signal Noise Ratio	100dB			
Working Voltage	10.5V-15.5V DC			
Width mm	185mm	225mm	225mm	225mm
Length mm	185mm	220mm	265mm	300mm
Height mm	62mm	68.5mm	68.5mm	68.5mm
Width inches	7.28"	8.86"	8.86"	8.86"
Length inches	7.28"	8.66"	10.43"	11.81"
Height inches	2.44"	2.70"	2.70"	2.70"

## DIGITAL MONOBLOCK FEATURES

- Digital Class-D Mono Block Amplifier
- Dual MOS-FET PWM Power Supply
- 1 Ohm Stable Load
- 12 dB/Octave - Variable Low Pass Filter
- 0 to 12dB - Variable Bass Boost
- 4 Way Protection Circuit (Thermal, Voltage Speaker short and DC Offset)
- Wired Remote Control with Clipping Indicator.

## DIGITAL MONOBLOCK SPECIFICATIONS

Tested @14.4Volts	SIA-1250D	SIA-1750D	SIA-2500D	SIA-3500D	SIA-5000D
1Ω Mono RMS	1250W	1750W	2500W	3500W	5000W
2Ω Mono RMS	1250W	1750W	2500W	3000W	4000W
4Ω Mono RMS	800W	1250W	2000W	1750W	2750W
Recommended Fuse Rating	120A	150A	220A	300A	2x250A
LoW Pass Filter (-12dB/8) Variable	40Hz - 20kHz				
High Pass Filter (-12dB/8) Variable	10Hz - 1kHz				
LEVEL (Bass Boost)	0 - 12dB (50Hz)				
Input Sensitivity	5V Max				
Signal Noise Ratio	108dB				
Working Voltage	10.5V - 15.5V DC				
Width mm	185mm	185mm	185mm	225mm	225mm
Length mm	145mm	165mm	185mm	200mm	350mm
Height mm	62mm	62mm	62mm	68.5mm	68.5mm
Width inches	7.28"	7.28"	7.28"	8.86"	8.86"
Length inches	5.71"	6.50"	7.28"	7.87"	13.78"
Height inches	2.44"	2.44"	2.44"	2.70"	2.70"

## PARALLEL WIRING OF DUAL COIL SUBWOOFERS

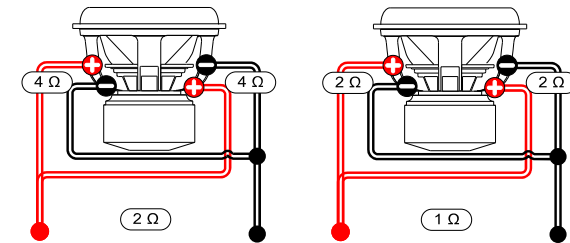

## SERIES WIRING OF DUAL COIL SUBWOOFERS

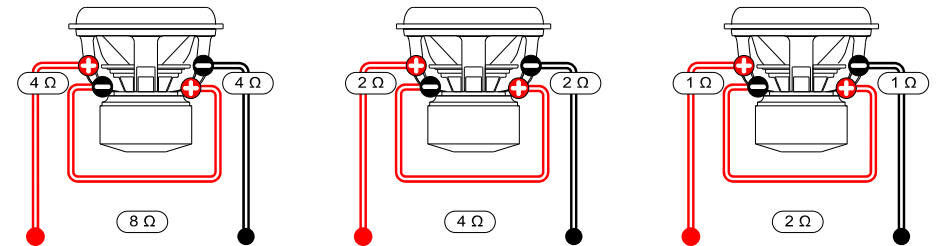

# SERIES/PARALLEL WIRING OF DUAL COIL SUBWOOFERS

## Subwoofer planning

When using more than one subwoofer, you have to make sure your total impedance does not go below the minimum level of the amp, see the specification charts for your amplifiers minimums. Use the chart below to help in your design.

		Coil Impedance		
		D4	D2	D1
Number of dual coil subwoofers	2	4.00	2.00	1.00
	3	2.67	1.33	0.67
	4	2.00	1.00	0.50
	5	1.60	0.80	0.40
	6	1.33	0.67	0.33
	7	1.14	0.57	0.29
	8	1.00	0.50	0.25

Safe for use where the minimum impedance is 2Ω and up

Safe for use where the minimum impedance is 1Ω and up

**DO NOT USE**  
Impedance is too low

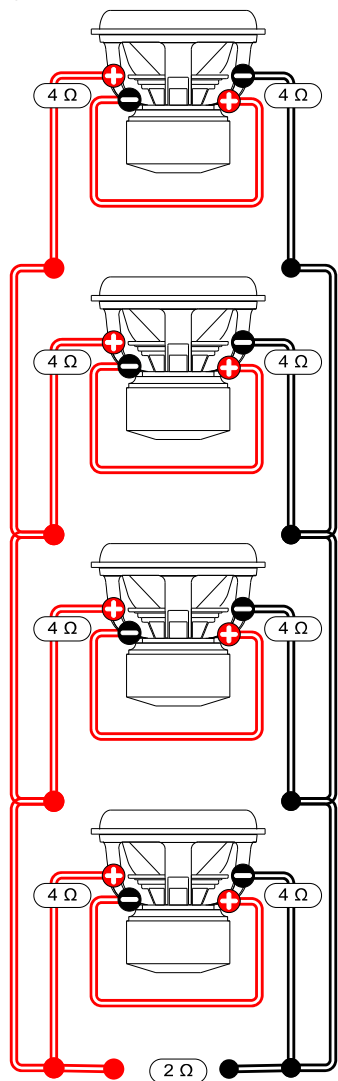

# WHAT DO ALL THE SWITCHES, KNOBS AND LIGHTS DO?

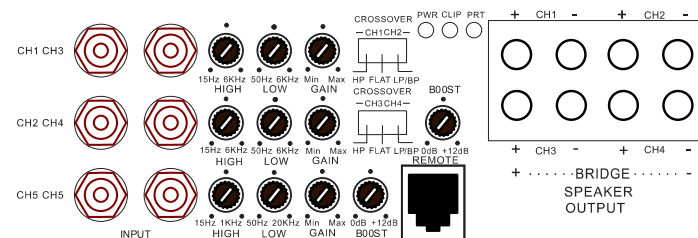

**CH1-CH5 RCA's:** RCA signal from source

**CH1-CH5 SPEAKER OUTPUTS-** This is where your speakers plug in, see the amp specific diagrams for assistance.

**GAIN-** NOT A VOLUME KNOB, THE INTERNET IS LYING TO YOU 😊, used to set the input signal levels, start from Min and slowly turn clockwise until you hear angels singing or the sirens from the cops looking for you. Scan this QR Code for a video on setting your gains



## CROSSOVER-

**HP-** Sets the crossover to only use the High pass filter

**FLAT-** Turns off the crossover filters (Warning, only use if you have external passive or active filters, not using filters can damage your speakers.

**LP/BP-** Sets the crossover for Low pass filter, can also be used for Bandpass

**HIGH -** High pass filter, used to set max high-level frequency

**LOW-** Low pass filter, used to set the minimum low-level frequency

**BOOST (LEVEL)-** Often called BASS BOOST, increases the 50Hz signal

**PWR –** Power LED, if it's on, your good, if its off, you're not good. See the troubleshooting section if it doesn't turn on.

**CLIP-** Clipping LED, if this is flashing or solid you could damage your speakers, turn down your gain.

**PRT-** Protect, the amp is in protect mode, see the troubleshooting section for assistance.

**Note-** The PWR, CLIP, and PRT leds will flash as a test when the amp is first powered on.

**REMOTE-** Plugin for the external bass knob, used to attenuate the from lowest point to the highest that was set on the amplifier

# POWER CONNECTIONS

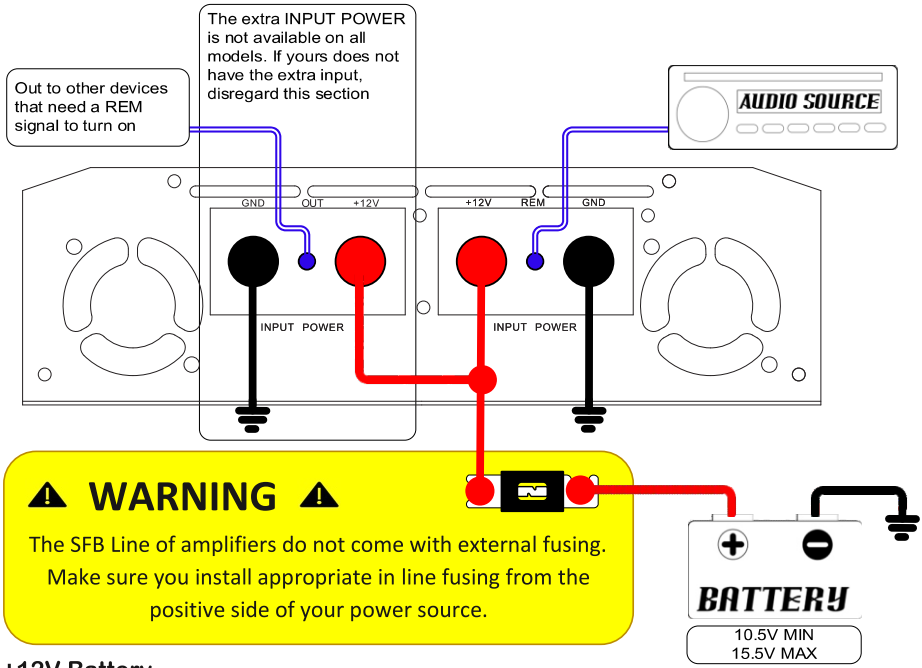

**⚠ WARNING ⚠**  
 The SFB Line of amplifiers do not come with external fusing. Make sure you install appropriate in line fusing from the positive side of your power source.

### +12V Battery

You need to connect a power wire to the vehicle's positive battery terminal. This connection must be tight and secure to ensure proper connectivity. This wire has to be fused appropriately (see each amplifier's fuse rating under specifications) within 12 to 16 inches for safety. You will then need to connect the power wire to the 12+ terminal of the amplifier with a Phillips screw driver. Do not install the fuses until installation is complete.

### Ground Connection

It is recommended that you connect your ground directly to your power source ground for the best possible performance. However, if you cannot, then the ground connection must be made to the vehicle's chassis and should be kept as short as possible, while accessing a solid piece of sheet metal in the vehicle. The surface should be sanded at the contact point to clean rust, paint or grime so a metal-to-metal connection between the chassis and the termination of the ground wire is effective. You will then need to connect the ground wire to the GND terminal of the amplifier with a Phillips screw driver.

### Remote

The +12V remote turn-on wire is typically controlled by the source unit's remote turn-on output. The amplifier will turn on when +12V is present at its remote ( REM ) input and turn off when +12V is switched off. Connect the remote wire using 12 to 16-gauge wire to the REM connection of the amplifier with Phillips screw driver, then connect the other end of the remote wire to either the source unit's turn on output or ignition switch circuit. The models that have the extra power input will have an extra REM connection noted as OUT, this is intended to allow you to connect your REM line to other devices if needed.

# 5 CHANNEL FULL RANGE INPUT AND SPEAKER CONNECTIONS

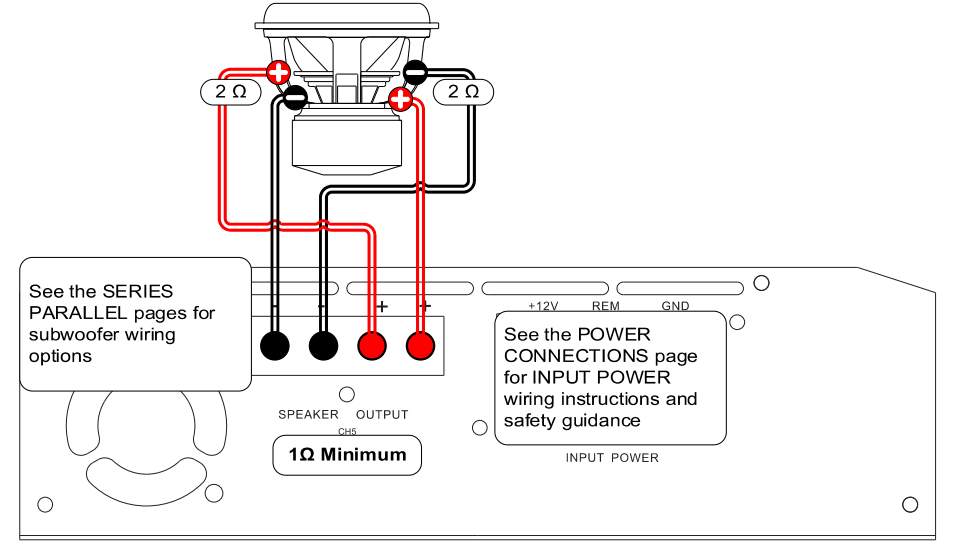
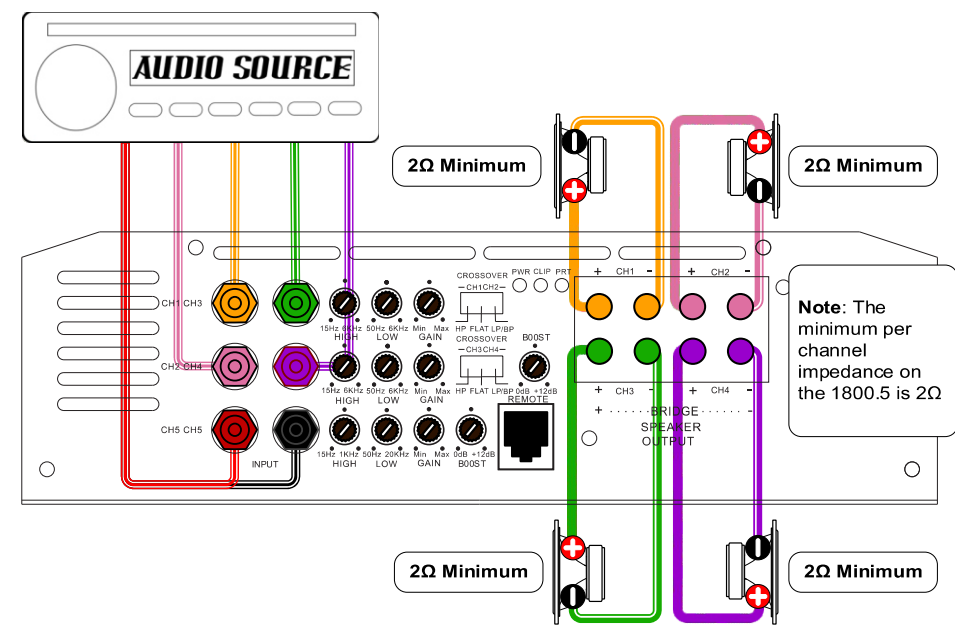

# 4 CHANNEL BRIDGE MODE FULL RANGE INPUT AND SPEAKER CONNECTIONS

Bridge mode example using a Dual Voice Coil Subwoofer

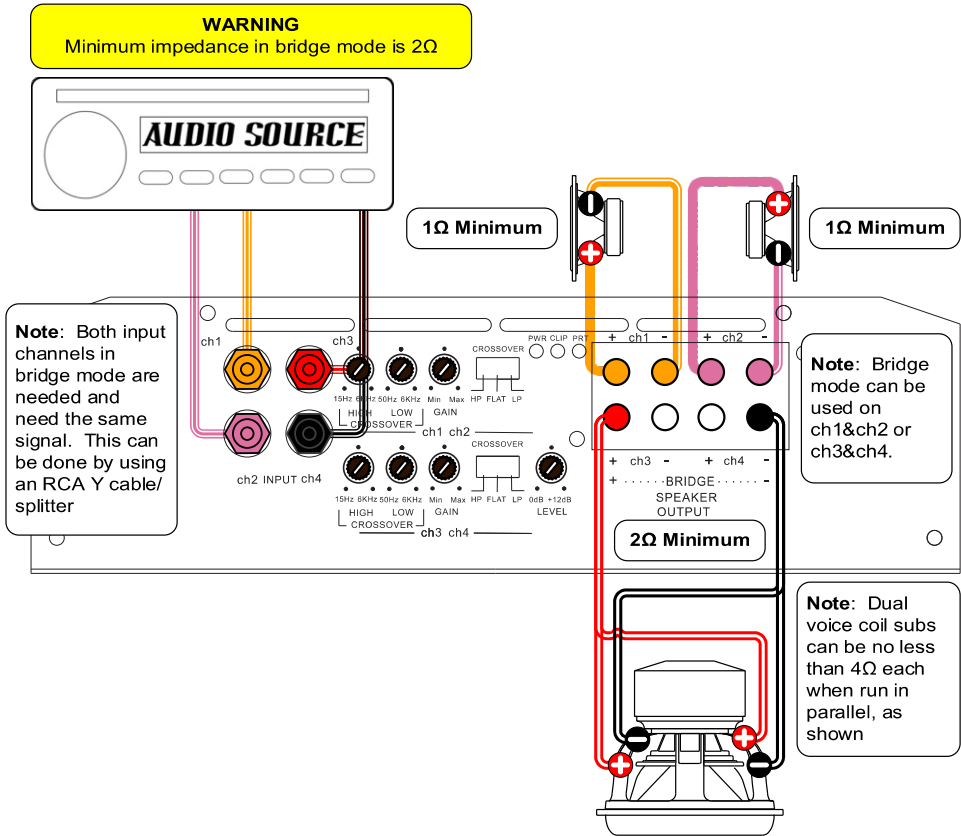

# MONOBLOCK INPUT AND SPEAKER CONNECTIONS

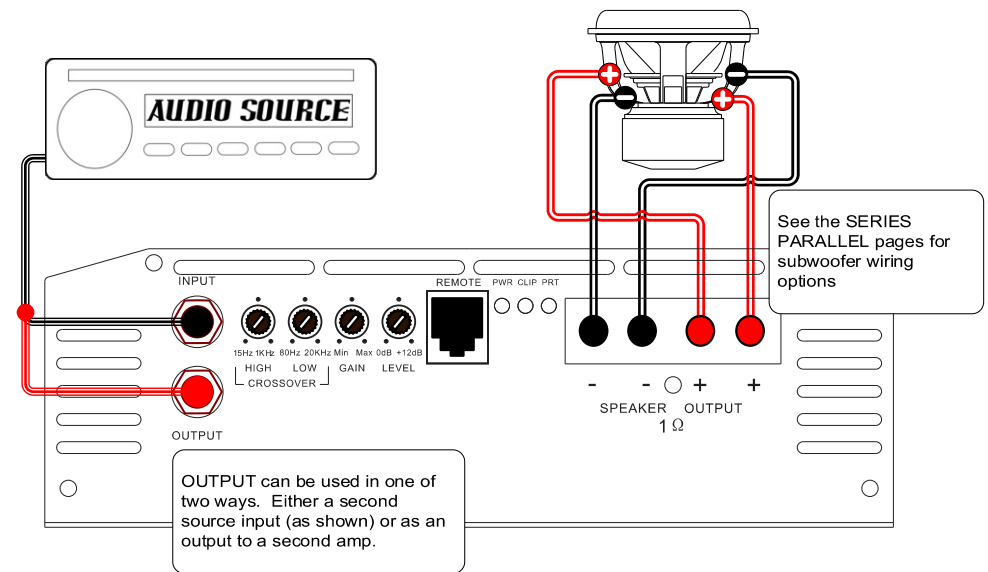

## 4 CHANNEL FULL RANGE INPUT AND SPEAKER CONNECTIONS

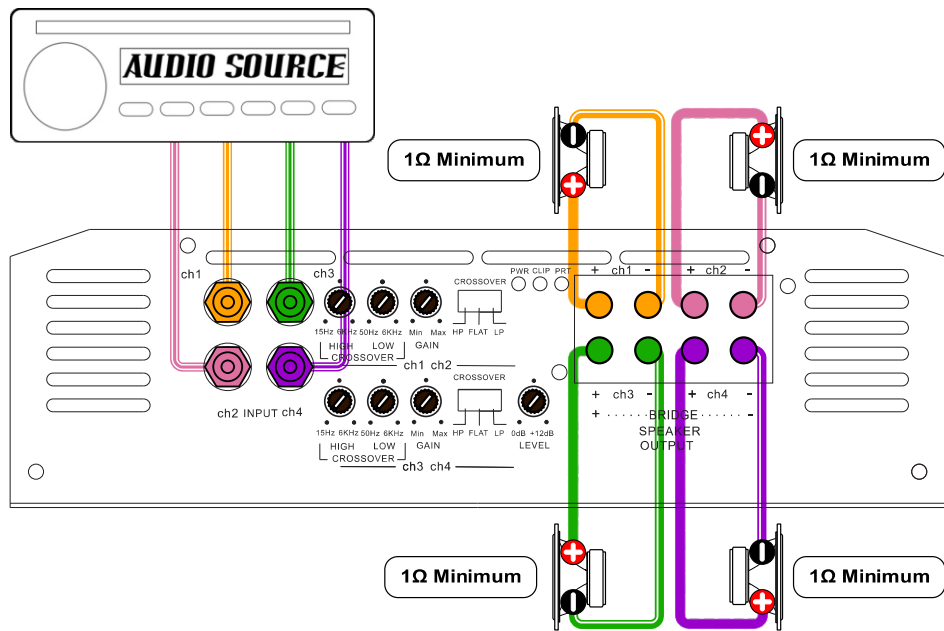

## 4 CHANNEL BRIDGE MODE FULL RANGE INPUT AND SPEAKER CONNECTIONS

Bridge mode examples for Series and Parallel wiring

**WARNING**  
Minimum impedance in bridge mode is 2Ω

**Note:** To calculate impedance in series (as shown for ch1/ch2) add all speakers together for total. Using the example to the right, 1Ω + 1Ω + 1Ω + 1Ω would give you 4Ω total

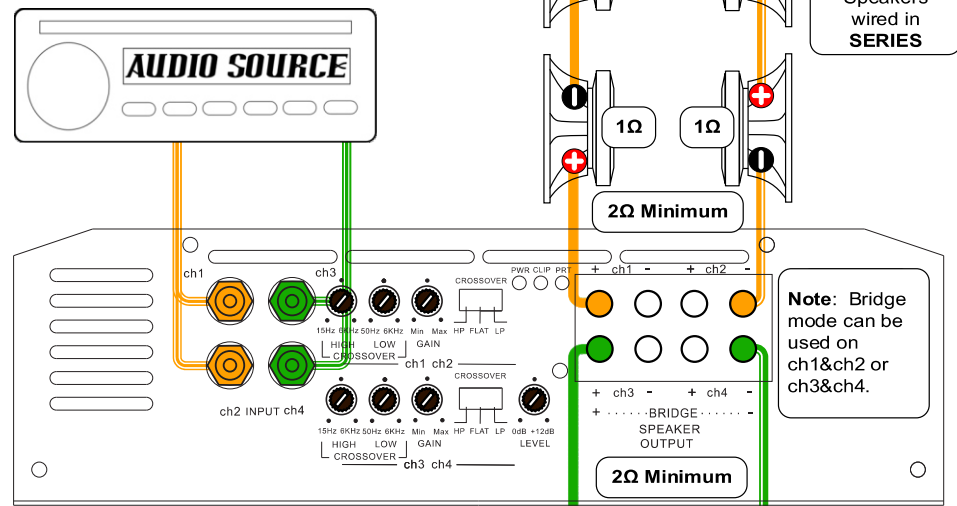

**Note:** To calculate impedance in parallel (as shown for ch3/ch4) divide speaker impedance by the number of speakers. Using the example to the right, divide 8 (for 8Ω speakers) by 4 (number of speakers) to get 2Ω total