

# Globalstar Sat-Fi™

## SAT-FI INSTALLATION & CONFIGURATION GUIDE



**TOLL FREE 1-888-989-8199**

1455 N. Dutton Suite A, Santa Rosa, CA 95401  
FAX 707-546-8198 • [info@remotesatellite.com](mailto:info@remotesatellite.com)  
[www.remotesatellite.com](http://www.remotesatellite.com)

This guide is based on the production version of the Globalstar Sat-Fi and Sat-Fi Apps. Software changes may have occurred after this printing.

Globalstar reserves the right to make changes in technical and product specifications without prior notice

Globalstar Inc.  
300 Holiday Square Blvd  
Covington, LA 70433

Copyright© 2015 Globalstar® Incorporated  
All rights reserved

Globalstar® is a registered trademark of Globalstar Incorporated

Sat-Fi™ is a registered trademark of Globalstar Incorporated

Android® is a registered trademark of Google Incorporated.

iPhone® is a registered trademark of Apple Incorporated.

All other trademarks and registered trademarks are properties of their respective owners

Printed in the United States of America



# Table of Contents

<b>1. WELCOME.....</b>	<b>1</b>
HOW SAT-FI WORKS.....	1
ABOUT THIS GUIDE .....	2
<b>2. WHAT'S INCLUDED.....</b>	<b>3</b>
<b>3. GLOBALSTAR SAT-FI INSTALLATION.....</b>	<b>4</b>
INSTALLATION PROCESS OVERVIEW.....	4
EXTERNAL SATELLITE ANTENNA INSTALLATION .....	4
<i>Marine Antenna Installation.....</i>	5
<i>Magnetic Patch (Car Antenna) Installation.....</i>	6
<i>Helix Antenna Installation.....</i>	7
SAT-FI UNIT MOUNTING.....	8
<i>3M Dual Lock Tape .....</i>	8
<i>3M Bumpon Feet.....</i>	8
COAXIAL CABLE CONNECTIONS.....	9
<i>Cable Connection to the External Antenna .....</i>	9
<i>Cable Connection to the Sat-Fi Unit.....</i>	9
WI-FI ANTENNA AND POWER CONNECTION .....	10
POWERING ON THE SAT-FI.....	11
<b>4. SETUP AND CONFIGURATION OF GLOBALSTAR SAT-FI.....</b>	<b>12</b>
CONNECTING TO THE SAT-FI WIRELESS NETWORK.....	12
ACCESSING THE GLOBALSTAR SAT-FI USER INTERFACE .....	13
<b>5. SAT-FI UNIT USER INTERFACE.....</b>	<b>14</b>
MONITORING NETWORK CONNECTIVITY.....	14
<i>Satellite Status Section.....</i>	15
<i>Wi-Fi Clients Section .....</i>	16
<i>DHCP Leases Section.....</i>	17
WI-FI CONFIGURATION PAGE.....	18
<i>Changing the SSID and Password.....</i>	19
<i>Changing the Wi-Fi Channel .....</i>	20
SERVICE INTEGRATION .....	21
ADMINISTRATION PAGE.....	22
<i>Changing Administrator Username and Password .....</i>	23
<i>Resetting the Sat-Fi to Factory Default .....</i>	23
LOG FILE PAGE .....	24
<b>6. GLOBALSTAR SAT-FI SPECIFICATIONS.....</b>	<b>25</b>
<b>7. REGULATORY APPROVAL .....</b>	<b>27</b>
FCC/IC NOTICE .....	27
GENERAL NOTICES.....	28
CE NOTICE .....	28
EUROPEAN DECLARATION OF CONFORMITY .....	28
<b>8. GENERAL WARNINGS .....</b>	<b>29</b>

9. WARRANTY INFORMATION ..... 30



## 1. WELCOME

---

Today's smartphones provide more options for staying in touch with friends and family than ever before. Unfortunately, they are dependent on the cellular network. Now you can take your smart phone beyond cellular with the world's most reliable satellite hotspot.

- Easily make calls, send emails and SMS from any Wi-Fi enabled device
- Conveniently use existing device contacts via the Sat-Fi App
- Enjoy affordable crystal-clear voice quality with seamless connectivity
- Fastest data speeds in the industry for sending and receiving email
- Designed for both vehicle/vessel-based and fixed locations
- Connect up to 8 users to Sat-Fi at one time
- Powered by the world's newest, most modern satellite network



### How Sat-Fi Works

Sat-Fi is a VoIP to satellite bridge allowing you to send and receive satellite calls through your smartphone. You will be able to carry just a single phone and use that smartphone on both your cellular and Globalstar's satellite network.

Sat-Fi is designed for both vehicle-based and fixed locations. Vehicle-based examples may include cars, trucks, RVs, ATVs as well as boats. Fixed location solutions may include remote areas where there is no cellular coverage and satellite communication is desired or needed.

An example of a typical Sat-Fi user would be a boat owner who uses a satellite phone when heading out on the water. With a Sat-Fi onboard, the owner does not have to carry both a smartphone and satellite phone; all he needs to do is simply register his smartphone on Sat-Fi when he boards. The owner is now free to move about the vessel while maintaining both cellular (if available) and satellite connectivity all on one phone. Additionally with a smartphone there is no need to achieve proper antenna alignment or have a clear view of the sky to send or receive satellite calls. If Sat-Fi is properly mounted, the owner can send or receive satellite calls anywhere on the vessel with his smartphone.

While normal mobile satellite phones are single user devices, Sat-Fi allows for multiple simultaneous user connections. While only one satellite call can be made at a time, up to 8 users may connect to a single Sat-Fi sharing its satellite connection. Once you are registered and connected to the Sat-Fi, you are immediately able to make outbound calls. Additional users and guests will be able to register their smartphones on Sat-Fi and make calls or data connections.

All calls and data connections are made through the Sat-Fi App. This app needs to be downloaded on your Android or iOS device in order to connect to the Globalstar network.

Sat-Fi turns your smartphone or wireless device into a satellite phone.

1. Download and install the Sat-Fi Apps to your smartphone or other wireless device.
2. Connect your device to the Sat-Fi via a Wi-Fi connection.
3. Sat-Fi links your device to the Globalstar Satellite Network.
4. Your device is now a connected for voice and data.

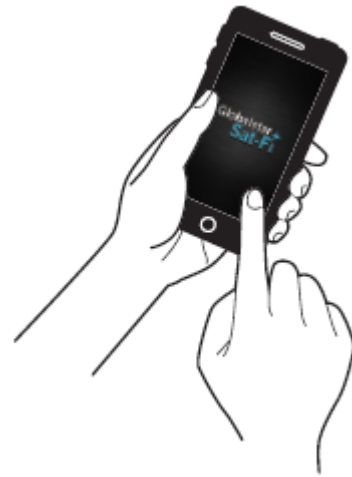

## About This Guide

The installation and configuration sections of this guide step through all aspects of setup, testing, and operation of the Sat-Fi. Please be sure to read this guide thoroughly and retain it for future reference. .

Professional installation is recommended.

## 2. WHAT'S INCLUDED

---

Your Globalstar Sat-Fi System comes with the following components:

- Globalstar Sat-Fi Unit
- Globalstar Sat-Fi Power Supplies
  - (1) 120-240VAC/12VDC Power Supply
  - (1) 12VDC Car Power Adapter
  - (1) Waterproof – DC Power Cable
- Globalstar External Antenna (one of the following antennas)
  - Marine Helix Antenna (GAT-17MR)
  - Helix Antenna (GAT-17HX)
  - Magnetic Patch Antenna (GAT-17MP)
- Accessory Kit
  - (6) 3M Dual Lock Mounting Tape (5" (12cm) Length
  - (4) 3M Bumpon Feet
  - (1) 14 feet/4.25 m Coaxial Antenna Cable
  - (1) Wi-Fi Antenna
  - (1) Rubber O-Ring

## 3. GLOBALSTAR SAT-FI INSTALLATION

---

### Installation Process Overview

The Globalstar Sat-Fi hardware installation process is very simple:

- Install/mount external antenna
- Secure Global Sat-Fi Unit to a flat surface area
- Connect Sat-Fi unit with external antenna

### External Satellite Antenna Installation

The Sat-Fi does not have an internal satellite antenna and the external satellite antenna is necessary for communication between the satellite and the Globalstar Sat-Fi unit. The single most important consideration of the Globalstar Sat-Fi installation is the location of the external antenna. The Sat-Fi external antenna needs a clear and unobstructed view of the sky in all directions. It must be in a position that minimizes obstructions that block the signal from the satellites and far enough away from other RF devices to prevent interference.

Your Globalstar Sat-Fi comes with one of the following external antennas, depending upon kit that you purchased:

- Marine Helix Antenna
- Helix Antenna
- Magnetic Patch Antenna

Marine Helix Antenna  
GAT-17MR



Helix Antenna  
GAT-17HX



Magnetic  
Patch Antenna  
GAT-17MP





## Marine Antenna Installation

There is more than one approach to mounting the marine external antenna and every vessel installation is different. Follow the below generic steps while installing the antenna:

- For best results the antenna should be mounted at the highest point on the vessel with a 360 degree view of the sky.
- The antenna must not be positioned within range of radar equipment or other RF interference.
- The antenna must be at least 3 feet (1 Meter) from other antennas (including GPS antennas).
- Use only the coaxial cables that come with the antenna kit.
  - Do not cut or modify the coaxial antenna cable.
  - Do not kink the coaxial cables
  - Do not use any additional coaxial antenna cables or non Globalstar coaxial antenna cables – Either of these modifications may damage the Sat-Fi unit, void the warranty and violate various government regulations
  - Extended length coaxial antenna cables are available (sold separately)
- Use adhesive lined heatshrink tubing to seal all external cable connections to prevent moisture and corrosion damage. Heatshrink tubing is available without the adhesive lining, but it does not completely protect the cables/connectors from salt and water ingress.
- Attach the marine antenna to a standard 14 threads per inch marine mast (not included).

**NOTE:** Use appropriate and sufficient mounting hardware to ensure proper and secure installation of the marine mast.

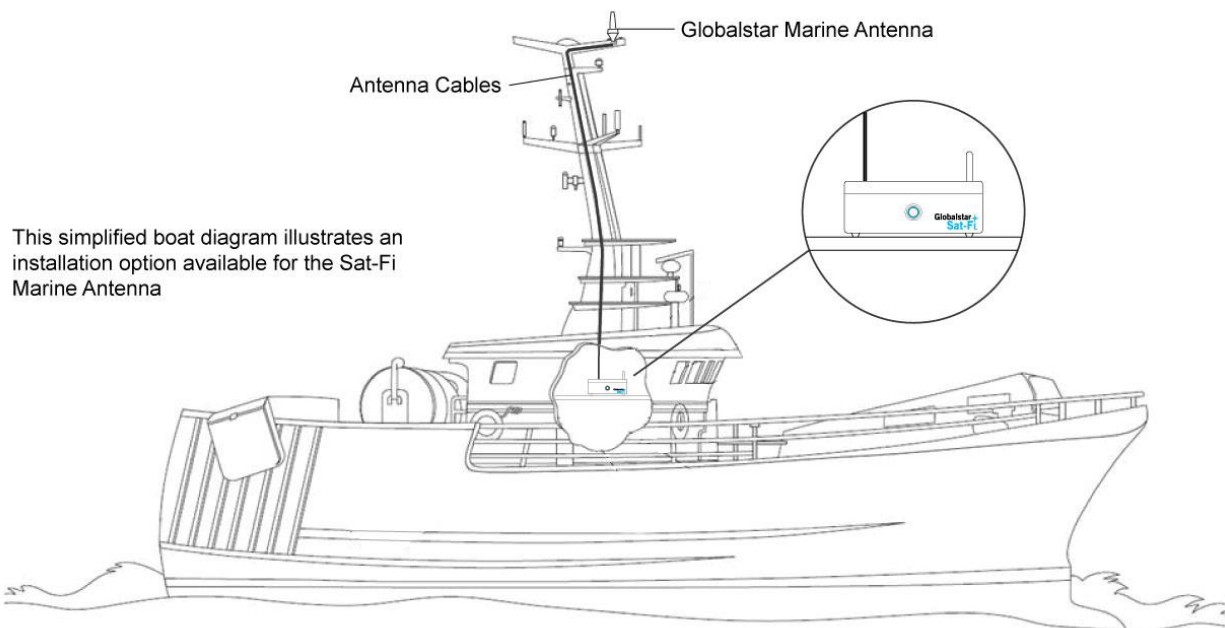

## Magnetic Patch (Car Antenna) Installation

An external magnetic patch (car antenna) is required for satellite communication when the Sat-Fi is used inside a vehicle.

- The external car antenna should be mounted on the roof of the vehicle with an unobstructed view of the sky.
- The external car antenna is easily mounted to the roof of your vehicle via its magnetic base.
  - Inspect the surface of the magnet for damage before placing the antenna on the car.
  - The external car antenna is not designed for high speed driving - use moderate speeds when mounted on the roof.
  - The metal surface on the underside of the external car antenna can get hot; use caution when taking it off the roof.
  - Do not mount the external car antenna on the trunk or a lower surface – performance could be affected.
- The external antenna uses coaxial cables that connect the antenna to the Sat-Fi. Use only the coaxial cables that come with the antenna kit. Do not cut or modify the coaxial antenna cable.
  - Do not use any additional coaxial antenna cables or non Globalstar coaxial antenna cables – Either of these modifications may damage the Sat-Fi unit, void the warranty and violate various government regulations
  - Use existing slots and channels in the vehicle for routing.
  - Route cables so that they will not tangle or interfere with the movement of seats, pedals and emergency brakes.
  - Avoid routing cables under floor mats so as not to catch on your feet.
  - Route cables so they are at least 6 inches from electrical cables so not to cause electrical interference.
  - Use coaxial sealant, shrink-wrap tubing, electrical tape, or other suitable products to seal all external cable connections to prevent moisture and corrosion damage.

This simplified vehicle diagram illustrates an installation option available for the Sat-Fi Magnetic Patch Antenna

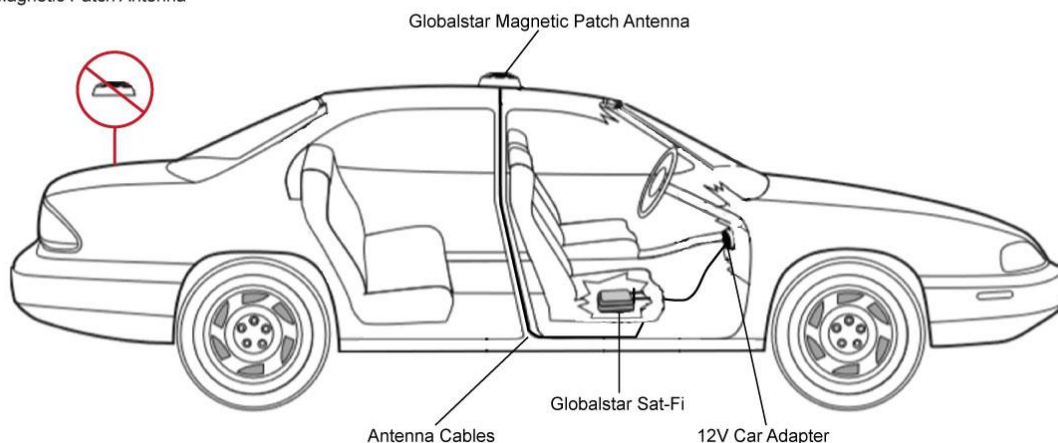

## Helix Antenna Installation

When selecting a location to mount the external antenna there are several issues to take into consideration:

- Mount the helix antenna so that it has a 360 degree view of the sky from 10 degrees above the horizon.
- The antenna must be at least 3 feet (1 meter) from other antennas (including GPS antennas).
- If mounting on a flat roof, avoid placing antenna near chimneys and other physical structures such as air handling units, etc.
- If the roof is inclined, place the antenna far enough above the peak so the roof does not cause signal blockage.
- Mount the antenna so that it is stable and not susceptible to vibration and movement in windy environments.
- Use only the coaxial cables that come with the antenna kit.
  - Do not cut or modify the coaxial antenna cable.
  - Do not use any additional coaxial antenna cables or non Globalstar coaxial antenna cables – Either of these modifications may damage the Sat-Fi unit, void the warranty and violate various government regulations
  - Extended length coaxial antenna cables are available (sold separately)
- Use coaxial sealant, shrink-wrap tubing, electrical tape, or other suitable products to seal all external cable connections to prevent moisture and corrosion damage.

## Sat-Fi Unit Mounting

Identify an appropriate location for the Sat-Fi unit to be mounted. The ideal location for the Sat-Fi unit should be within the cable length of the external antenna and in a dry location close to an AC/DC power source. Additionally, it should be centered in a location you wish to cover, to maximize its 100ft Wi-Fi radius.

**NOTE:** There must be a separation of at least 10" (25cm) between the Sat-Fi Wi-Fi antenna and all persons, and a separation of at least 10" (25cm) between the Sat-Fi and any other antenna or transmitter.

The following materials are provided to mount the Sat-Fi unit:

- 3M Dual Lock Tape
- 3M Bumpon Feet

### 3M Dual Lock Tape

The 3M Dual Lock Tape included in the accessories kit is recommended for mounting in vehicles and boats.

3M DUAL LOCK MOUNTING TAPE  
ON BOTTOM OF SAT-FI DEVICE

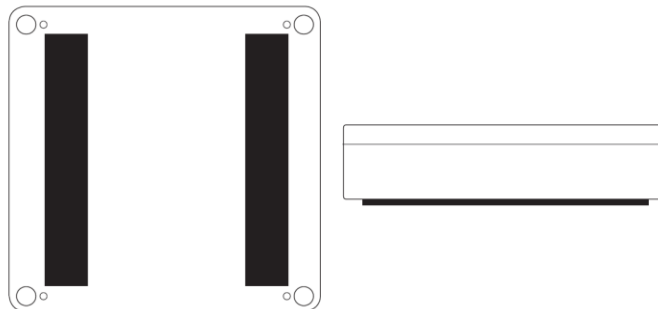

### 3M Bumpon Feet

The 3M Bumpon Feet included in the accessories kit is recommended for fixed locations on land.

BUMPON FEET ON BOTTOM  
OF SAT-FI DEVICE

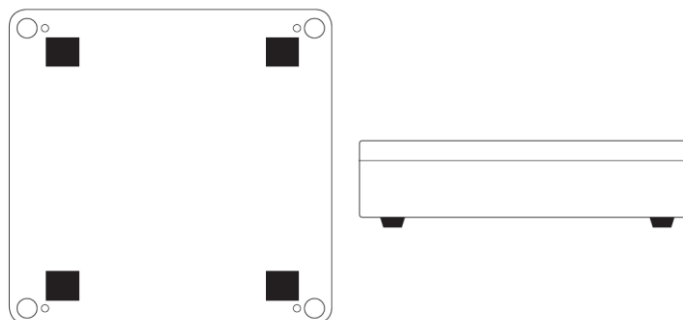

## Coaxial Cable Connections

After the external antenna and Sat-Fi unit have been installed and mounted in their appropriate locations, the antenna cables and power need to be connected.

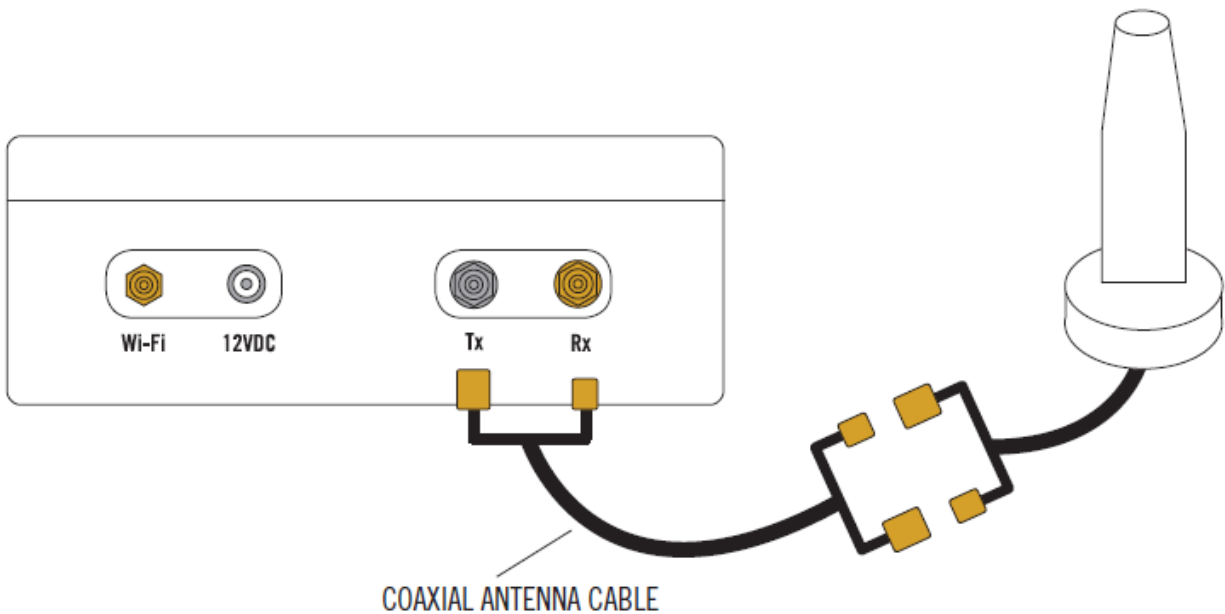

### Cable Connection to the External Antenna

1. Connect the Transmit (Tx) connector of the antenna coaxial cable to the Transmit (Tx) port on the external antenna.
2. Connect the Receive (Rx) connector of the antenna coaxial cable to the Receive (Rx) port on the external antenna.

### Cable Connection to the Sat-Fi Unit

1. Connect the Transmit (Tx) connector of the antenna coaxial cable to the Transmit (Tx) port on the Sat-Fi unit.
2. Connect the Receive (Rx) connector of the antenna coaxial cable to the Receive (Rx) port on the Sat-Fi unit.

## Wi-Fi Antenna and Power Connection

Perform the following for the Wi-Fi Antenna connection:

1. Place the rubber O-Ring over the Wi-Fi antenna port.
2. Connect the Wi-Fi antenna to the Wi-Fi port on the back of the Sat-Fi Unit - Finger tighten only.

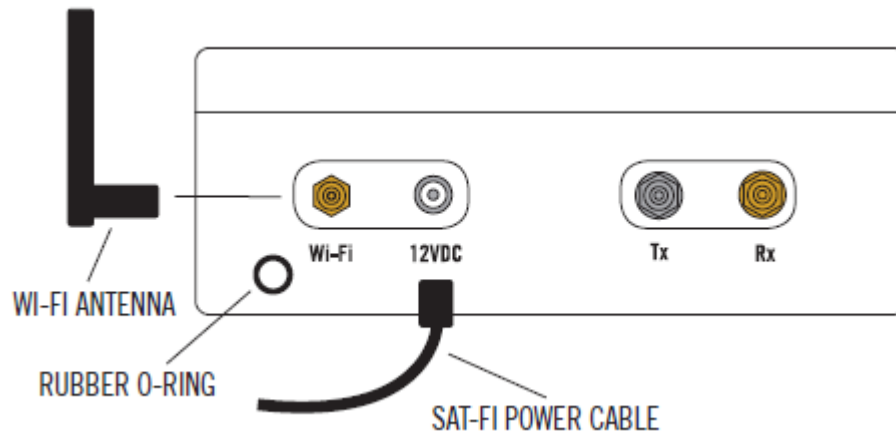

3. Connect the appropriate power cable (120-240VAC/12VDC Power Supply or 12VDC Car Power Adapter) to the 12VDC power port on the Sat-Fi unit.

## Powering on the Sat-Fi

The Sat-Fi automatically powers on when it is connected to a power source. The single push button in the front acts as a hard power reset switch allowing the Sat-Fi to be easily restarted without having to physically disconnect the power. Once powered on, the Sat-Fi performs the following sequence:

- Automatically boots
- Enables the Wi-Fi
- Attempts to register with the Globalstar Satellite Network

This process may take up to 30 seconds to complete.

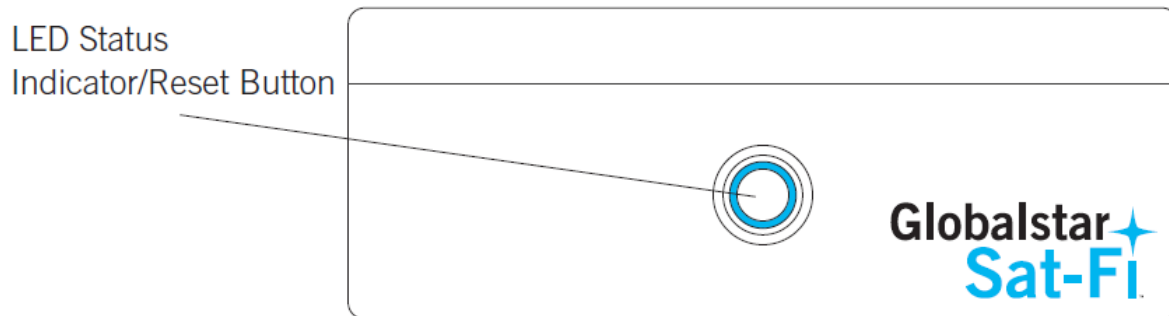

The LED on the front panel provides a visual indication of the Sat-Fi's status:

- **ON (Solid)** – The Sat-Fi is registered with the Globalstar Satellite Network and is able to send/receive calls and data
- **Fast Blinking** – The Sat-Fi is searching for service and/or registering with the Globalstar Satellite Network
- **Slow Blinking** – The Sat-Fi is in use; either sending/receiving a call or data transmission
- **OFF** – The Sat-Fi is powered off and not connected to a power source

## 4. SETUP AND CONFIGURATION OF GLOBALSTAR SAT-FI

---

### Connecting to the Sat-Fi Wireless Network

Your smartphone or other wireless device must connect via Wi-Fi to the Sat-Fi to access the user interface. The Sat-Fi is shipped with a default Wi-Fi configuration as follows:

- **Wi-Fi Network Name:** SatFi<XXXX> (<XXXX> is a unique identifier of the Sat- Fi Unit)  
**Example: SatFi6A3E90**
- **Password:** Satfi1234

Perform the following steps to connect your smartphone or other wireless device to the Sat-Fi:

1. On your smartphone or other wireless device, turn on your Wi-Fi connection and attempt to connect to the SatFi<Unique Identifier> network.
2. A Wi-Fi connection dialog will be displayed. In the Password text-entry field, enter the appropriate password.
3. Press the **Connect** button.

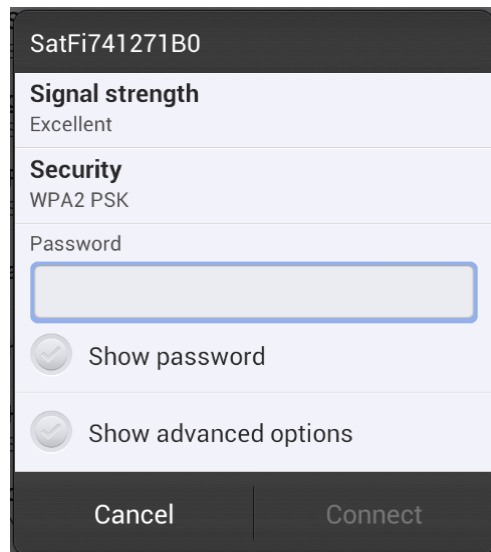

4. You should now be connected to the Sat-Fi Wi-Fi network.



## Accessing the Globalstar Sat-Fi User Interface

If for any reason you would like to change the Sat-Fi logon password or for other administrative purposes, the Sat-Fi User Interface may be accessed by any web browser from a smartphone, computer or other wireless device connected to the Globalstar Sat-Fi Wireless Network.

Perform the following to access the Sat-Fi User Interface:

1. Open your web browser.
2. In the address bar enter: <http://192.168.1.1>
3. A Sign In dialog will be displayed.
  - In the **Name** field, enter the administrator name.
  - In the **Password** field, enter the password.
  - Press the **Sign in** button.

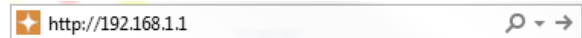

**NOTE:** By default the username is **admin** and the password is **admin**.

4. You will now be logged into the Sat-Fi User Interface.

## 5. SAT-FI UNIT USER INTERFACE

The Sat-Fi Unit is configured via a web-based interface. This interface allows you to:

- Monitor network connectivity
- Configure the Wi-Fi
- Change administrator's password
- Reset system to factory defaults
- View diagnostic information

### Monitoring Network Connectivity

The Sat-Fi Status Page provides an overview of the systems health and status. This page is helpful in diagnosing problems with sending and receiving phone calls. Additionally, the Sat-Fi Status page refreshes every 30 seconds providing a real time view of the system.

The Sat-Fi Page consists of three sections:

- Satellite Status
- Wi-Fi Clients
- DHCP Lease

The screenshot displays the Globalstar Sat-Fi Status web interface. The page title is "SatFi Status" and it includes a navigation menu with links for Status, WiFi Configuration, Service Integration, Administration, and Log File. The main content area is titled "SatFi Status" and features a refresh timer of 27 seconds. The interface is divided into four sections:

- Satellite Status:** A table showing the current state of the satellite connection.
 

State	Online	Mode	Provider	Gateway	RSSI	Roaming
idle	yes	globalstar	gstar usa	4		no
- Call Timers:** A section showing lifetime voice and data usage.
 

Lifetime Voice	Lifetime Data
10:15:15	0:00:45
- WiFi Clients:** A table listing connected Wi-Fi devices.
 

MAC Address	Signal Avg	Bitrate	Authenticated	Rx Bytes	Tx Bytes	Inactive Time
d4:20:6d:cf:27:0a		65.0 MBit/s MCS 7	yes	79110	39982	15 ms
- DHCP Leases:** A table showing active DHCP leases.
 

MAC Address	IP Address	Hostname	Lease Expires
d4:20:6d:cf:27:0a	192.168.1.248	Android_358967045911797	Tue Oct 29 12:34:25 EDT 2013
a8:26:d9:c7:fe:ee	192.168.1.245	Android_359788040332287	Tue Oct 29 12:34:25 EDT 2013

At the bottom of the page, there is a footer with the text: gateway 3.2.0-60-generic #91-Ubuntu SMP Wed Feb 19 03:54:44 UTC 2014 | © Copyright 2014 Globalstar, All Rights Reserved

## Satellite Status Section



The Satellite Status section displays the following satellite connectivity characteristics:

Satellite Status						
State	Online	Mode	Provider	Gateway	Sat Signal	Roaming
idle	yes	voice	gstar usa	1		no

- **State** – Displays the connection status:
  - **idle** – The Sat-Fi is ready to send and receive calls, but is not currently active
  - **unregistered** – The Sat-Fi is not yet registered with the Globalstar Network
  - **dialing** – The Sat-Fi is placing an outbound call
  - **ringing** – The Sat-Fi is receiving an inbound call or in the process of connecting an outbound call
  - **active** – The Sat-Fi currently in a call
  - **unknown** – The Sat-Fi is not responding and has encountered an error.
- **Online** – Displays whether the Sat-Fi is communicating with the Globalstar Network:
  - **yes**
  - **no**
- **Mode** – Displays the Sat-Fi communication mode:
  - **voice** – A voice call is taking place
  - **data** – A data transmission session is taking place
- **Provider** – Displays the satellite network provider
- **Gateway** – Displays the connecting Sat-Fi gateway
- **RSSI** – Displays the receive signal strength of the satellite
- **Roaming** – Displays if the Sat-Fi is roaming from its home network:
  - **yes** – Additional charges may apply when sending or receiving satellite communications
  - **no** – The Sat-Fi is within its home network and no roaming charges will apply

## Wi-Fi Clients Section

The Wi-Fi Clients section displays the following characteristics of all current and recently connected smartphones and other wireless devices:

MAC Address	Signal Avg	Bitrate	Authenticated	Rx Bytes	Tx Bytes	Inactive Time
54:26:96:49:54:85		11.0 MBit/s	yes	17968	4442	1250 ms
1c:b0:94:94:9c:06		72.2 MBit/s MCS 7 short GI	yes	31155	29122	54 ms
5c:0a:5b:a5:dc:92		54.0 MBit/s	yes	83742	97887	937 ms

- **MAC Address** – Displays the Media Access Control (MAC) address of the connected device. This is the unique hardware address of the Wi-Fi system within your device.
- **Signal Avg** – Displays the average received signal strength of the connected device. A series of four bars displays the strength of the signal from the smartphone or other device. Devices with fewer bars may have problems sending/receiving phone calls and data.
- **Bitrate** – Displays the communication rate with the connected device.
- **Authenticated** – Displays whether the device has been authenticated:
  - **yes** – The device will be able to send/receive calls and data.
  - **no** - The device will not be able send/receive calls and data.
- **Rx Bytes** – Displays the total number of bytes that the Sat-Fi unit has received from a connected device.
- **Tx Bytes** – Displays the total number of bytes that the Sat-Fi unit has transmitted to the connected device.
- **Inactive Time** – Displays the amount of time since the smartphone or other wireless device has last communicated with the Sat-Fi.

## DHCP Leases Section

When a smartphone or other wireless device connects to the Sat-Fi, it is assigned an IP address by the DHCP server. The DHCP Leases section maps the device's MAC address to their assigned IP address.

MAC Address	IP Address	Hostname	Lease Expires
54:26:96:49:54:85	192.168.1.240	GlobalsariPhone	Tue Mar 04 03:26:26 UTC 2014
1c:b0:94:94:9c:06	192.168.1.246	*	Tue Mar 04 03:26:05 UTC 2014
5c:0a:5ba5:dc:92	192.168.1.250	android-2bac11e9972e9d3c	Tue Mar 04 03:05:14 UTC 2014

- **MAC Address** – Displays the Media Access Control (MAC) address of the connected device. This is the unique hardware address of the Wi-Fi system within your device
- **IP Address** – Displays the IP address assigned to your smartphone or other wireless device
- **Hostname** – Displays the hostname assigned to your smartphone or other wireless device by the Sat-Fi
- **Lease Expires** – Displays the time when the DHCP Lease will expire and the smartphone or other wireless device will have to acquire a new IP address

## Wi-Fi Configuration Page

The Wi-Fi Configuration page is used to configure the Sat-Fi's Wi-Fi connection/authentication information. On this page you can:

- Change the SSID name
- Change the login password
- Change the Wi-Fi channel

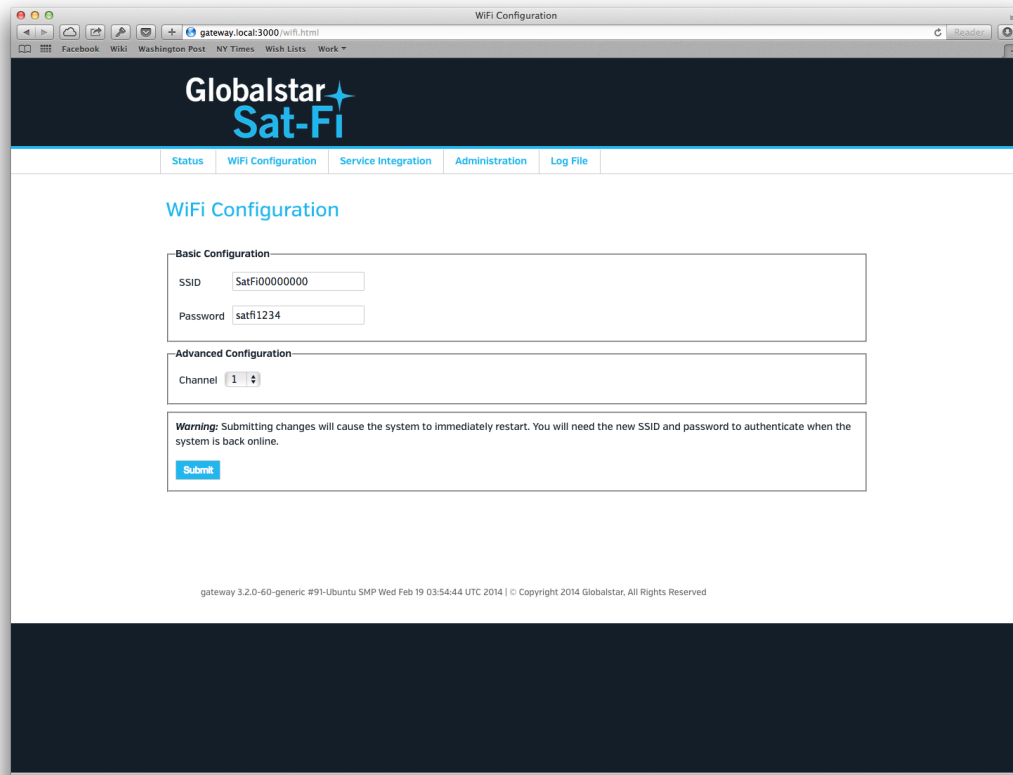

The screenshot shows a web browser window titled "WiFi Configuration" with the URL "gateway.local:3000/wifi.html". The page features the Globalstar Sat-Fi logo at the top and a navigation menu with links for Status, WiFi Configuration, Service Integration, Administration, and Log File. The main content area is titled "WiFi Configuration" and contains two configuration sections: "Basic Configuration" with input fields for SSID (SatFi00000000) and Password (satfi1234), and "Advanced Configuration" with a dropdown menu for Channel (1). A warning message states: "Warning: Submitting changes will cause the system to immediately restart. You will need the new SSID and password to authenticate when the system is back online." Below the warning is a blue "Submit" button. At the bottom of the page, a small copyright notice reads: "gateway 3.2.0-60-generic #91-Ubuntu SMP Wed Feb 19 03:54:44 UTC 2014 | © Copyright 2014 Globalstar, All Rights Reserved".

## Changing the SSID and Password

The SSID is the name of the Wi-Fi network hosted by Sat-Fi. By default this is **SatFi<XXXX>** (where <XXXX> is a unique identifier of the Sat-Fi Unit).

The default password to access the Sat-Fi's Wi-Fi is **satfi1234**. Globalstar recommends that you change the password to prevent unauthorized use of your Sat-Fi system.

Basic Configuration

SSID

Password

To change your SSID and password, perform the following:

1. In the **SSID** field, enter a new Wi-Fi network name. This value must be 5 to 32 characters in length.
2. In the **Password** text-entry field, enter a new password. The password must be 8 to 63 characters in length and can contain letters, numbers and special characters.
3. Press the **Submit** button.

**WARNING: Pressing the Submit button will automatically restart the Sat-Fi. If the SSID and Password have been changed, all smartphones and other wireless devices will have to manually reconnect and login to the Sat-Fi.**

4. A warning dialog box will be displayed, press **OK**.

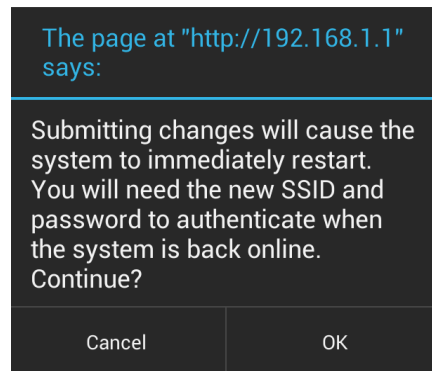

5. The Sat-Fi Unit will shut down and restart. Login using the new SSID and Password.

## Changing the Wi-Fi Channel

In areas where there might be a significant number of Wi-Fi channels, it may be necessary to change the channel to improve Wi-Fi connectivity with your smartphone and other wireless devices. Changing the channel will have no effect on satellite connectivity.

Advanced Configuration

Channel

To change the Wi-Fi channel perform the following:

1. In the **Channel** text-entry field, enter a new channel number. This value can be 1 to 11.
2. Press the **Submit** button.

**NOTE: Pressing the Submit button will automatically restart the Sat-Fi.**

3. Repeat Steps 1 and 2 if there are still any Wi-Fi connectivity problems.



## Service Integration

The Service Integration Mode must be set to Openity One.

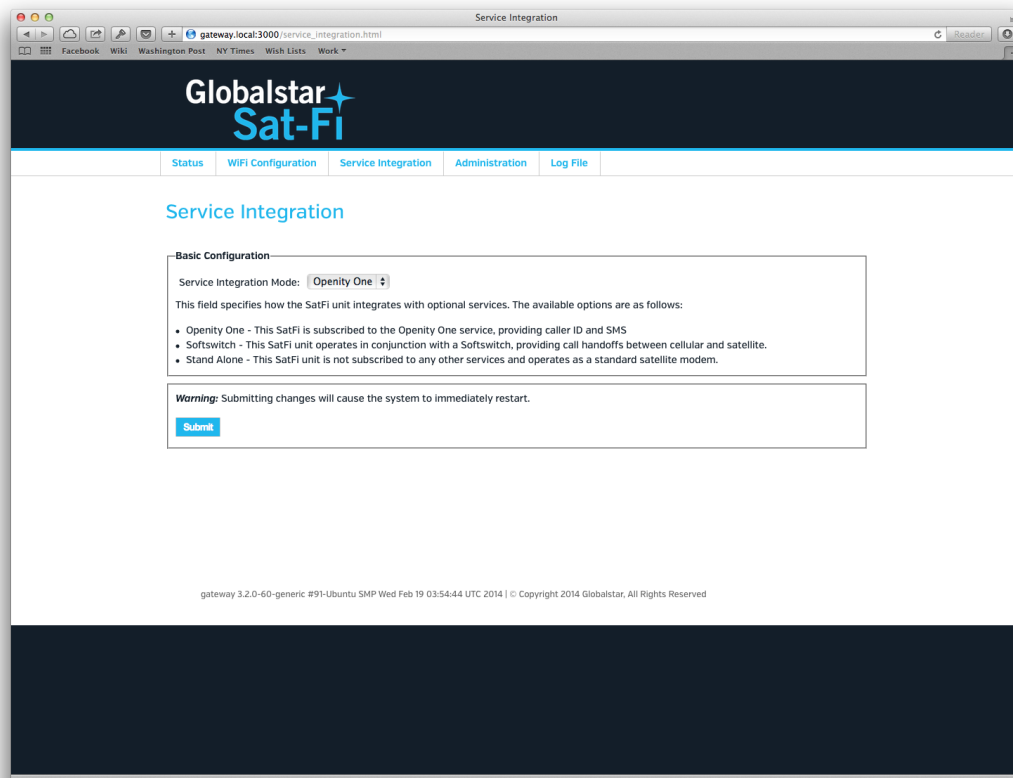

If it is not set to Openity One, perform the following:

1. Click on the Service Integration Mode drop-down menu and select **Openity One**.
2. Press the **Submit** button.

**NOTE: Pressing the Submit button will automatically restart the Sat-Fi.**

## Administration Page

The Administration page provides the ability to change the administrator username and password, along with the ability to reset the Sat-Fi to its factory settings.

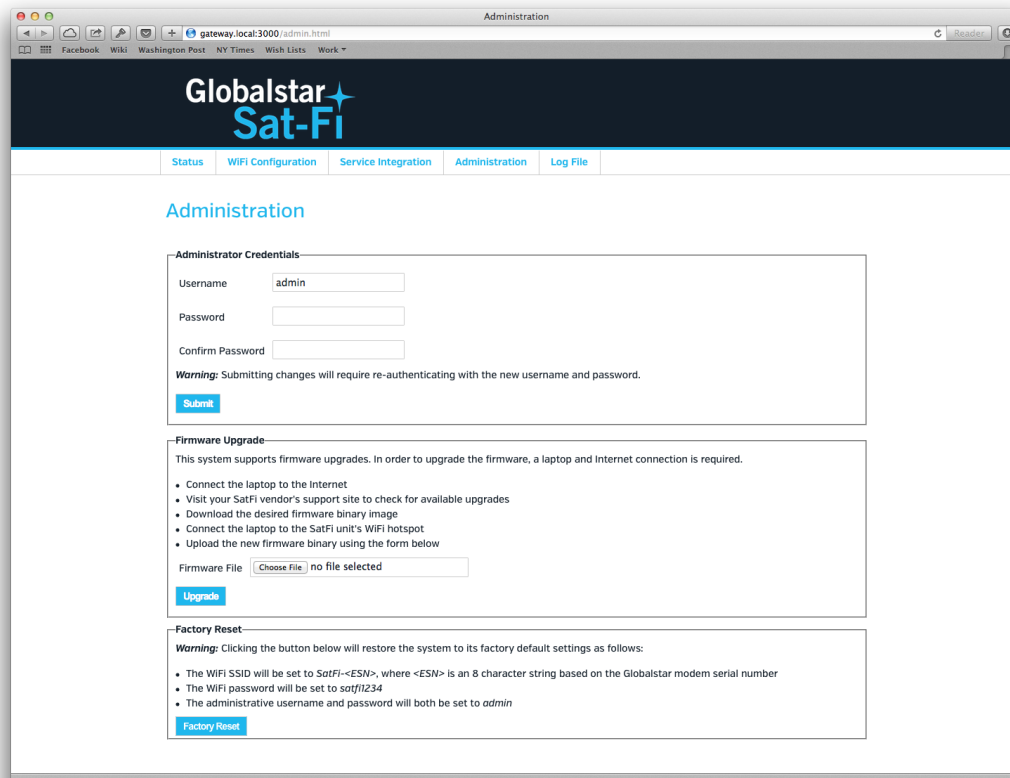

## Changing Administrator Username and Password

The Username and Password are used to log in as administrator for the Sat-Fi User Interface.

Administrator Credentials

Username

Password

Confirm Password

*Warning:* Submitting changes will require re-authenticating with the new username and password.

To change your username and password perform the following:

1. In the **Username** field, enter a new username. This value must be 5 to 32 characters in length.
2. In the **Password** field, enter a new password. The password must be 8 to 63 characters in length and can contain letters, numbers and special characters.
3. In the **Confirm Password** field, re-enter the same password you entered in Step 2.
4. Press the **Submit** button.

**WARNING: Pressing the Submit button will automatically restart the Sat-Fi. You will be required to sign in using your new username and password.**

5. A warning dialog box will be displayed, press **OK**.

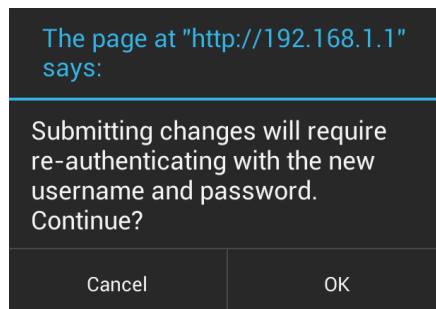

## Resetting the Sat-Fi to Factory Default

Pressing the Factory Reset button will automatically restore the Sat-Fi to its original factory settings. The Sat-Fi will automatically restart as part of the process and if the SSID and Password have been changed, all smartphones and other wireless devices will have to manually reconnect and login to the Sat-Fi.

Factory Reset

*Warning:* Clicking the button below will restore the system to its factory default settings as follows:

- The WiFi SSID will be set to *FireCracker-<MAC>*, where *<MAC>* is a 4 character string based on the MAC address
- The WiFi password will be set to *firecracker*
- The administrative username and password will both be set to *admin*

## Log File Page

The Log File page displays the current contents of the Sat-Fi diagnostic log and may be used by Globalstar Customer Care to help troubleshoot any issue that may occur.



```

192.168.1.1/log
-- Logs begin at Sat 2000-01-01 00:00:13 UTC, end at Mon 2014-03-03 15:28:16 UTC. --
May 01 00:00:13 overo systemd-journal[57]: Runtime journal is using 120.0K (max 24.6M, leaving 36.9M of free 246.3M,
current limit 24.6M).
May 01 00:00:13 overo systemd-journal[57]: Runtime journal is using 124.0K (max 24.6M, leaving 36.9M of free 246.3M,
current limit 24.6M).
May 01 00:00:13 overo kernel: Booting Linux on physical CPU 0
May 01 00:00:13 overo kernel: Initializing cgroup subsys cpuset
May 01 00:00:13 overo kernel: Initializing cgroup subsys cpu
May 01 00:00:13 overo kernel: Linux version 3.5.0 (support@openity-build) (gcc version 4.7.2 (GCC) ) #1 PREEMPT Wed Jan 29
13:18:54 PST 2014
May 01 00:00:13 overo kernel: CPU: ARMv7 Processor [413fc082] revision 2 (ARMv7), cr=10c5387d
May 01 00:00:13 overo kernel: CPU: PIPT / VIPT nonaliasing data cache, VIPT aliasing instruction cache
May 01 00:00:13 overo kernel: Machine: Gumstix Overo
May 01 00:00:13 overo kernel: cma: CMA: reserved 16 MiB at 9e800000
May 01 00:00:13 overo kernel: Memory policy: ECC disabled, Data cache writeback
May 01 00:00:13 overo kernel: Dn node 0 totalpages: 129280
May 01 00:00:13 overo kernel: free_area_init_node: node 0, pgdat c067dffc, node_mem_map c06b8000
May 01 00:00:13 overo kernel: Normal zone: 1024 pages used for memmap
May 01 00:00:13 overo kernel: Normal zone: 0 pages reserved
May 01 00:00:13 overo kernel: Normal zone: 128256 pages, LIFO batch:31
May 01 00:00:13 overo kernel: OMAP3630 ES1.2 (12cache neon isp 192mhz_clk )
May 01 00:00:13 overo kernel: Clocking rate (Crystal/Core/MPU): 28.0/332/400 MHz
May 01 00:00:13 overo kernel: pcpu-alloc: s0 r0 d32768 u32768 alloc=1*32768
May 01 00:00:13 overo kernel: pcpu-alloc: [0] 0
May 01 00:00:13 overo kernel: Kernel command line: console=tttyO2,115200n8 consoleblank=0 mpurate=500 root=ubi0:rootfs
ubi.mtd=4 rootfstype=ubifs
May 01 00:00:13 overo kernel: PID hash table entries: 2048 (order: 1, 8192 bytes)
May 01 00:00:13 overo kernel: Dentry cache hash table entries: 65536 (order: 6, 262144 bytes)
May 01 00:00:13 overo kernel: Inode-cache hash table entries: 32768 (order: 5, 131072 bytes)
May 01 00:00:13 overo kernel: allocated 1048576 bytes of page cgroup

```

## 6. GLOBALSTAR SAT-FI SPECIFICATIONS

External Satellite Antenna	
Antenna Types	Active
Antenna Power	7VDC – Supplied by primary Sat-Fi Power Supply
Operating Frequency	Transmit (TX) 1610 – 1626 MHz
	Receive (RX) 2483.5 – 2500 MHz
Transmit Power	+31dBm EIRP
External Connectors	TX – SMA Female
	RX – SMA Male
Environment	Storage: -40°F to +185°F (-40°C to +85°C)
	GAT-17HX/GAT-17MR -22°F to +140°F (-30°C to +60°C)
	GAT-17MP -4°F to +131°F (-20°C to +55°C)

Wi-Fi Antenna	
Antenna Types	Dipole
Operating Frequency	2400 – 2500 MHz
Environment	-40°F to +185°F (-40°C to +85°C)

Sat-Fi Unit	
Input Power	12VDC
Max Power Input	14W
Dimensions	6.3" (W) x 6.3" (L) x 2.4" (H) 16cm (W) x 16cm (L) x 6.1cm (H)
External Connectors	TX – SMA Male port
	RX – SMA Female port
	Power – 12VDC port
	RP-SMA Antenna Mount
Environment	Storage: -40°F to +185°F (-40°C to +85°C)
	Operational: -22°F to +140°F (-30°C to +60°C)
Signaling	SIP
DTMF Format	RFC2833
# Voice Channels	1
Audio Codes	G.711u

<b>Coaxial Cable</b>	
Insertion Loss	Transmit (TX) Cable: 5.8dB – 6.4dB
	Receive (RX) Cable: 0.0dB – 10.0dB

## 7. REGULATORY APPROVAL

---

### FCC/IC Notice

Contains FCC ID: J9CGSSDVM / IC: 2723A-GSSDVM

Contains FCC ID: TFB-TIWI1-01 / IC: 5969A-TIWI101

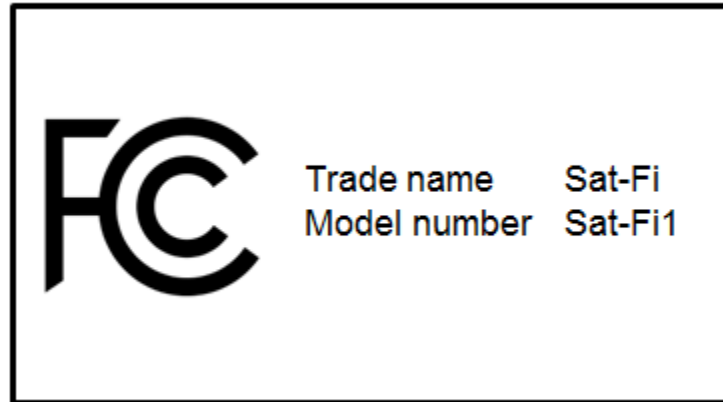

This equipment has been tested and found to comply with the limits for a Class A digital device, pursuant to part 15 of the FCC Rules. These limits are designed to provide reasonable protection against harmful interference when the equipment is operated in a commercial environment. This equipment generates, uses, and can radiate radio frequency energy and, if not installed and used in accordance with the instruction manual, may cause harmful interference to radio communications. Operation of this equipment in a residential area is likely to cause harmful interference in which case the user will be required to correct the interference at his own expense.

Responsible Party for FCC Compliance:

Openity  
10328 Battleview Parkway  
Manassas, VA 20109  
USA  
1-855-673-6490

This Class A digital apparatus complies with Canadian ICES-003.

CAN ICES-3(A)/NMB-3(A)

## General Notices

Changes or modifications not expressly approved by the party responsible for compliance could void the user's authority to operate the equipment.

Sat-Fi must be used with a Globalstar-approved antenna. It is designed to comply with the established ANSI, FCC, and international safety standards for safe levels of human exposure to RF energy. Maintaining a minimum line-of-sight separation distance of 25 centimeters (10 inches) between the transmitting antenna and all personnel will ensure that the General Population/Uncontrolled Exposure maximum permissible exposure (MPE) limits are not exceeded.

This device complies with the requirements for Radio Astronomy Site avoidance as specified by the Globalstar National Science Foundation agreement of 2001. It is compliant with CFR25.213

## CE Notice

# CE0168









## European Declaration of Conformity

Hereby, Globalstar Europe Satellite Services Ltd, declares that this Globalstar Sat-Fi is in compliance with the essential requirements and other relevant provisions of Directive 1999/5/EC. The Declaration of Conformity may be consulted at <http://eu.globalstar.com/en/sat-fi>.



## 8. GENERAL WARNINGS

---

-  **Warning - Antenna Separation:** The Wi-Fi and Satellite antennas are to be separated from each other and any person by at least 25 cm (10 inches) to prevent interference and to protect the user.
-  **Warning - Antennas:** Use only the supplied or an approved replacement antenna or cable in the configurations stated in the manual. Unauthorized antennas, modifications, attachments or non-compliant configurations could damage the Sat-Fi, may violate various government regulations, and/or create a hazard to safety.
-  **Warning - Installation and Service:** Allow only authorized personnel to install or service the Sat-Fi and accessories. Faulty installation or service can be dangerous and can invalidate the warranty.
-  **Warning - Modifications:** Changes or modifications not expressly approved by the party responsible for compliance could void the user's authority to operate the equipment.
-  **Warning - Internal Batteries:** The coin battery inside the Sat-Fi should never need to be replaced. If replacement is needed, have an authorized service person replace with the battery with one of the same size and type.
-  **CAUTION – Internal Batteries :** Risk of explosion if battery is replaced by an incorrect type.
-  **Warning - Blasting Areas:** To avoid interfering with blasting operations, turn your Sat-Fi off when in a “blasting area” or in areas posted: “Turn off two-way radio”. Obey all signs and instructions.
-  **Warning - Potentially Explosive Atmospheres:** Turn your phone off when in any area with a potentially explosive atmosphere and obey all signs and instructions.
-  **Warning - Blinking LED:** The Sat-Fi uses slow or fast blinking patterns to help signify connection status. Persons with Photosensitive Epilepsy should take appropriate precautions.

## 9. WARRANTY INFORMATION

---

Globalstar USA, LLC. ("GUSA") offers you a limited warranty valid only in the USA that the enclosed product (the "Product") will be free from defects in material and workmanship under normal use and service for a time specified below from the date of sale of the Product to you, provided that you are the original end-user purchaser of the Product and provided that your purchase was made from a GUSA authorized supplier. Transfer or resale of a product will automatically terminate warranty coverage with respect to that Product. This limited warranty is not transferable to any third party, including but not limited to any subsequent purchaser or owner of the Product. The warranty time period for the Product is as follows:

- Sat-Fi Unit: one (1) year
- Antenna one (1) year after installation\*
- Batteries: 6 months
- Accessories: ninety (90) days

\*Installation will be deemed to be no later than thirty (30) days from the date of the sale of the Product to you.

GUSA shall, at its sole absolute discretion, either repair or replace a Product with a new or a rebuilt unit (which unit may include new and/or reconditions parts or boards of similar quality and functionality) if found by GUSA to be defective in material or workmanship, or if GUSA determines that it is unable to repair or replace such Product, provided that the subject Product (i) is returned to a GUSA authorized service center within the warranty period, and (ii) is accompanied by a proof of purchase in the form of a bill of sale or receipted invoice which evidences that the subject Product is within the warranty period (Proof of Purchase). After the warranty period, you must pay all shipping, parts and labor charges. All replaced or refunded Products or parts will become the property of GUSA.

This limited warranty does not cover and is void with respect to the following: (i) a product which has been improperly installed, repaired, maintained or modified; (ii) a Product which has been subject to misuse (including a Product used in conjunction with hardware electrically or mechanically incompatible or used with accessories not supplied or approved by GUSA), abuse, accident, physical damage, abnormal operation or operation contrary to furnished instructions or warnings, improper handling, neglect, exposure to fire, water or excessive moisture or dampness or extreme changes in climate or temperature; (iii) Products operated outside published maximum ratings; (iv) cosmetic damage; (v) damage to antennas unless caused directly to defects in materials or workmanship; (vi) coil cords and control cables that are stretched, pinched, or have the modular tab broken; (vii) Products on which warranty stickers or Product serial numbers have been removed, altered or rendered illegible; (viii) customer instruction; (ix) cost of installation, removal or reinstallation; (x) signal reception problems (unless caused by defects in materials or workmanship); (xi) damage as a result of fire, flood, or other acts of God or other acts which are not the fault of GUSA and which the Product is not specified to tolerate, including but not limited to damage caused by mishandling, shipping or blown fuses; (xii) consumables (such as fuses); or (xiii) any Products which have been opened, repaired, modified or altered by anyone other than GUSA or a GUSA authorized service center.

USE WITH ACCESSORIES NOT SUPPLIED BY GUSA OR OTHERWISE NOT EXPRESSLY AUTHORIZED BY GUSA MAY BE DANGEROUS AND MAY VOID THE PRODUCT WARRANTY.

GUSA SPECIFICALLY DISCLAIMS LIABILITY FOR ANY AND ALL DIRECT, INDIRECT, SPECIAL, GENERAL, INCIDENTAL OR CONSEQUENTIAL DAMAGES, INCLUDING BUT NOT LIMITED TO LOSS OF PROFITS OR ANTICIPATED PROFITS ARISING OUT OF USE OF OR INABILITY TO USE ANY PRODUCT (FOR EXAMPLE, EXTRA AIRTIME CHARGES DUE TO THE MALFUNCTION OF A PRODUCT).

REPAIR, REPLACEMENT OR REFUND, AS PROVIDED UNDER THE WARRANTY IS YOUR SOLE AND EXCLUSIVE REMEDY FOR BREACH OF THE LIMITED WARRANTY. EXCEPT TO THE EXTENT PROHIBITED BY APPLICABLE LAW, ANY IMPLIED WARRANTY OF MERCHANTABILITY OR FITNESS FOR A PARTICULAR PURPOSE ON THESE PRODUCTS IS LIMITED IN DURATION TO THE DURATION OF THIS WARRANTY. TO THE EXTENT PERMITTED BY APPLICABLE LAW, GUSA MAKES NO OTHER WARRANTIES OF ANY KIND, EXPRESS OR IMPLIED, WITH RESPECT TO THE PRODUCTS, INCLUDING BUT NOT LIMITED TO ANY WARRANTY AGAINST INFRINGEMENT.

Some States do not allow the exclusion of limitation of incidental or consequential damages or allow limitations on how long an implied warranty lasts, so the above limitations or exclusions may not apply to you.

This limited warranty gives you specific rights, and you may also have other rights that vary from State to State.

To obtain warranty service, please call the following telephone number toll free anywhere in the continental United States: 1-877-GLBLSTAR (1-877-452-5782)