

VERSITRON®

Your Copper to Fiber Connection



SG70660M

**6-Port 10/100/1000
Web Smart Managed Switch
with 100/1G SFP Slot**

User's Manual

v2.00

© 2023
VERSITRON, Inc.
83 Albe Drive / Suite C
Newark, DE 19702
www.versitron.com

Copyright © VERSITRON, Inc. All rights reserved. All brand and product names are trademarks or registered trademarks of their respective companies.

PROPRIETARY DATA

All data in this manual is proprietary and may not be disclosed, used or duplicated, for procurement or manufacturing purposes, without prior written permission by **VERSITRON**.

VERSITRON LIFETIME WARRANTY

All VERSITRON products are covered by a **Lifetime Warranty** against defects in materials and workmanship. This coverage is applicable to the original purchaser and is not transferable.

We repair, or at our option, replace parts/products that, during normal usage and operation, are proven to be defective during the time you own the products, provided that said products and parts are still manufactured and/or available. Such repair/replacement is subsequent to receipt of your product at our facility and our diagnostic evaluation and review of the unit. Advance replacements are not provided as part of the warranty coverage.

This warranty does not cover damage to products caused by misuse, mishandling, power surges, accident, improper installation, neglect, alteration, improper maintenance, or other causes which are not normal and customary applications of the products and for which they were not intended. No other warranty is expressed or implied, and VERSITRON is not liable for direct, indirect, incidental or consequential damages or losses.

In the unlikely event a warranty issue should arise, simply contact us at 302-894-0699 or 1-800-537-2296 or via email at fiberlink@versitron.com to obtain a Return Material Authorization (RMA) number, along with instructions for returning your product.

About This Manual

Copyright

Copyright © 2016 VERSITRON, Inc. All rights reserved.

The products and programs described in this manual are licensed products of VERSITRON, Inc. This manual contains proprietary information protected by copyright, and this manual and all accompanying hardware, software and documentation are copyrighted. No parts of this manual may be copied, photocopied, reproduced, translated or reduced to any electronic medium or machine-readable form by any means by electronic or mechanical, including photocopying, recording, or information storage and retrieval systems, for any purpose other than the purchaser's personal use, and without the prior express written permission of VERSITRON, Inc.

Purpose

This manual gives specific information on how to operate and use the management functions of the SG70660M.

Audience

The Manual is intended for use by network administrators who are responsible for operating and maintaining network equipment; consequently, it assumes a basic working knowledge of general switch functions, the Internet Protocol (IP), and Simple Network Management Protocol (SNMP).

Conventions

The following conventions are used throughout this manual to show information.



NOTE: Emphasizes important information or calls your attention to related features or instructions.



WARNING: Alerts you to potential hazard that could cause personal injury.



CAUTION: Alerts you to a potential hazard that could cause loss of data, or damage the system or equipment.

Warranty

See the VERSITRON, Inc. warranty statement.

Disclaimer

VERSITRON, Inc. does not warrant that the hardware will work properly in all environments and applications, and marks no warranty and representation, either implied or expressed, with respect to the quality, performance, merchantability, or fitness for a particular purpose. VERSITRON, Inc. disclaims liability for any inaccuracies or omissions that may have occurred. Information in this User's Manual is subject to change without notice and does not represent a commitment on the part of VERSITRON, Inc.. VERSITRON, Inc. assumes no responsibility for any inaccuracies that may be contained in this User's Manual. VERSITRON, Inc. makes no commitment to update or keep current the information in this User's Manual, and reserves the right to make improvements to this User's Manual and /or to the products described in this User's Manual, at any time without notice.

Table of Contents

1. Introduction	3
1.1 Features.....	3
1.2 Product Panels.....	5
1.3 LED Indicators.....	5
1.4 Specifications	5
2. Installation.....	8
2.1 Unpacking	8
2.2 Safety Cautions.....	8
2.3 Mounting the Switch	9
2.4 Applying Power	9
2.5 Reset Button	10
2.6 Making UTP Connections.....	10
2.7 Making Fiber Connection.....	12
2.8 LED Indication.....	13
3. Manage the Switch.....	14
3.1 IP Address & Password.....	14
3.2 Configuring IP Address & Password via telnet.....	14
3.3 Configuring IP Address via Web Interface	15
3.4 Reference Manuals for Web and Telnet Management.....	17
3.5 Configuration for SNMP Management.....	18
3.6 SNMP MIBs.....	19
3.6.1 SNMP Traps.....	20

1. Introduction

The SG70660M is a 6-port Gigabit Ethernet switch which is featured with the following communication ports:

- Five 10/100/1000Mbps Gigabit copper ports
- One dual-speed SFP slot for 100Base-FX 1000Base-X



Plug and Play

The switch is shipped with a factory default configuration which behaves like an unmanaged Gigabit switch for workgroup usage. It provides five 10/100/1000Mbps copper ports for connections to Ethernet, Fast Ethernet, and Gigabit Ethernet devices. With the featured auto-negotiation function, the switch can detect and configure the connection speed and duplex automatically. The switch also provides auto MDI/MDI-X function, which can detect the connected cable and switch the transmission wire pair and receiving pair automatically. This auto-crossover function can simplify the type of network cables used.

Fiber Connectivity

The mini-GBIC SFP slot can be populated with an optional fiber optic SFP module to support one Gigabit, or Fast Ethernet fiber connection when needed.

Web Management

The switch is embedded with an Http server which provides management functions for advanced network functions including Port Control, Quality of Service, and Virtual LAN functions. The management can be performed via a Web browser based interface over TCP/IP network.

1.1 Features

- Five 10/100/1000Mbps RJ-45 and one dual-speed SFP slot
- All copper ports support auto-negotiation and auto-MDI/MDI-X detection.
- The SFP slot supports dual speed for 100BASE-FX and 1000BASE-X SFP transceivers.
- Full wire speed forwarding
- Supports 802.3x flow control for full-duplex and backpressure for half-duplex

- Supports SFP with Digital Diagnostic Monitoring (DDM)
- Provides fiber Optical Power Alarm (OPA) function
- Provides Automatic Laser Shutdown (ALS) function
- Management:
 - HTTP/HTTPS/SSHv2/CLI telnet/SNMP v1/v2c/v3/RMON
 - DHCP/DHCPv6 client, DHCP relay, DNS client, NTPv4
 - IPv6 support, System Syslog, Configuration down/upload, Software upload
- Security:
 - NAS, 802.1X, MAC-based/Web/CLI authentication
 - IP MAC binding, TACACS+, IP source guard
- Layer 2:
 - QoS, 802.1Q/MAC-based/Protocol-based/Private/IP subnet VLAN, Port Isolation
 - Storm control for UC/MC/BC packets, Static MAC configuration
 - IGMP v2/v3 snooping, MLD v1/v2 snooping, DHCP snooping
 - Multiple Spanning Tree - MSTP, RSTP, STP
- Specific SNMP implementation:
 - Private MIB for reading DDM status
 - Private MIB for remote boot the device over SNMP
 - Private MIB for TFTP firmware update over SNMP
 - Private MIB for configuring OPA function
 - Private MIB for configuring ALS function
 - OPA alarm traps

1.2 Product Panels

The following figure illustrates the front panel and rear panel of the switch:

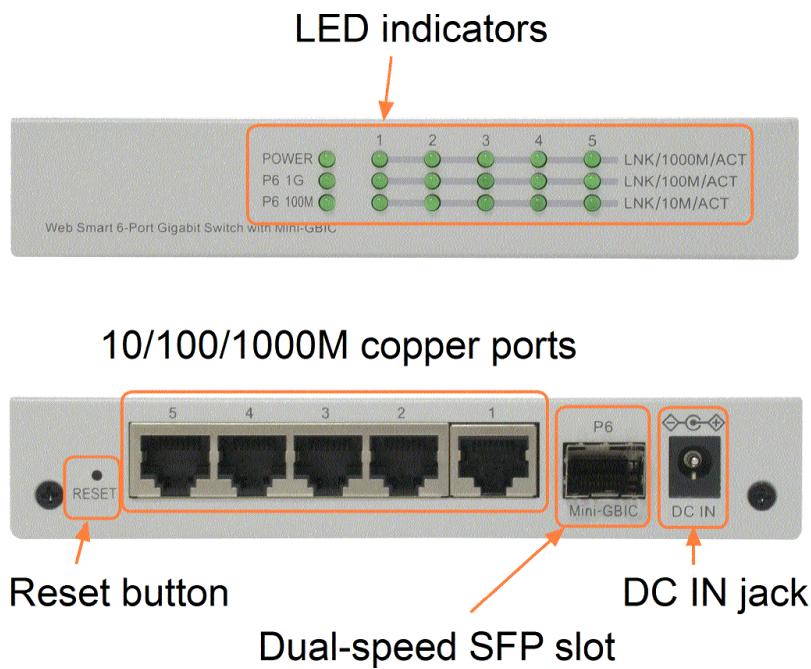

1.3 LED Indicators

LED	Function
POWER	Power status
LNK/1000M/ACT	Network port 1000Mbps link status (Port 1 - Port 5)
LNK/100M/ACT	Network port 100Mbps link status (Port 1 - Port 5)
LNK/10M/ACT	Network port 10Mbps link status (Port 1 - Port 5)
P6 1G	Port 6 1000Mbps link status
P6 100M	Port 6 100Mbps link status

1.4 Specifications

10/100/1000 Copper Ports (Port 1 ~ Port 5)

Compliance	IEEE 802.3 10Base-T, IEEE 802.3u 100Base-TX, IEEE 802.3u 1000Base-T
Connectors	Shielded RJ-45 jacks
Pin assignments	Auto MDI/MDI-X detection
Configuration	Auto-negotiation or software control
Transmission rate	10Mbps, 100Mbps, 1000Mbps
Duplex support	Full/Half duplex

Network cable Cat.5 UTP

Dual-speed SFP Slot (Port 6)

Compliance IEEE 802.3u 100Base-FX
 IEEE 802.3z 1000Base-SX/LX (mini-GBIC)

Connectors SFP for optional SFP type fiber transceivers

Configuration Auto 1000Mbps, Full duplex
 Forced 100Mbps, Full duplex

Transmission rate 100Mbps and 1000Mbps

Network cables MMF 50/125 62.5/125, SMF 9/125

Eye safety IEC 825 compliant

Switch Functions

MAC Addresses Table 8K entries

Forwarding & filtering Non-blocking, full wire speed

Switching technology Store and forward

Maximum packet length 9.6K bytes

IP Multicast groups 8192 supported

Flow control IEEE 802.3x pause frame base for full duplex operation
 Back pressure for half duplex operation

VLAN function Port-based VLAN and IEEE 802.1Q Tag-based VLAN
 4095 VLANs supported, IVL support

QoS function Port-based, 802.1p-based, IP DSCP-based

Port control Port configuration control via software management

Storm control Broadcast, Multicast storm protection control via software management

Aggregation Link aggregation (port trunking)

Port Mirroring Mirror received frames to a sniffer port

Software Management Functions

Interfaces Web browser

Management objects System configuration - IP settings, Name, Password
 Port configuration control and status, VLAN function settings
 Port Link Aggregation function settings
 Link Aggregation LACP settings, RSTP settings
 802.1X port access control, Port mirroring settings
 QoS function settings, Storm protection control settings
 Port statistic, LACP status, RSTP status

Configuration file backup and restore
Reboot, restore factory default, update firmware

DC Power Input

Interfaces DC Jack (-D 6.3mm / + D 2.0mm)
Operating Input Voltages +5V - 30VDC(+/-5%) via external power adapter
Power consumption 5.4W @12V (DC IN)
6W @5V (DC IN)

Mechanical

Dimension (base) 144 x 104.5 x 26 mm
Housing Enclosed metal with no fan
Mounting Desktop mounting, wall mounting

Environmental

Operating Temperature Typical -10°C ~ +45°C (Main device)
(* The operating temperature range of the bundled power adapter may differ from
the temperature range of the main device.)
Storage Temperature -40°C ~ +85°C
Relative Humidity 5% ~ 95%

Electrical Approvals

FCC Part 15 rule Class A
CE EMC, CISPR22 Class A
VCCI V-3 Class A
LVD Safety IEC 60950-1

2. Installation

2.1 Unpacking

The product package contains:

- The switch unit
- One power adapter

2.2 Safety Cautions

To reduce the risk of bodily injury, electrical shock, fire and damage to the product, observe the following precautions:

	Do not service any product except as explained in your system documentation.
	Opening or removing covers may expose you to electrical shock.
	Only a trained service technician should service components inside these compartments.
	If any of the following conditions occur, unplug the product from the electrical outlet and replace the part or contact your trained service provider: <ul style="list-style-type: none">- The power cable, extension cable, or plug is damaged.- An object has fallen into the product.- The product has been exposed to water.- The product has been dropped or damaged.- The product does not operate correctly when you follow the operating instructions.
	Do not push any objects into the openings of your system. Doing so can cause fire or electric shock by shorting out interior components.
	Operate the product only from the type of external power source indicated on the electrical ratings label. If you are not sure of the type of power source required, consult your service provider or local power company.

2.3 Mounting the Switch

The switch can be mounted on a desktop or shelf or a wall. Make sure that there is proper heat dissipation from and adequate ventilation around the device. Do not place heavy objects on the device.

Mounting holes for wall mounting

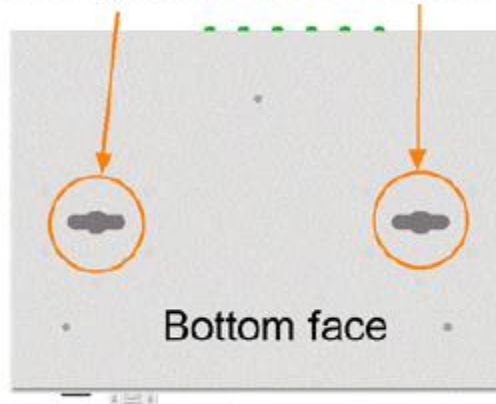

2.4 Applying Power

Before you begin the installation, check the AC voltage of your area. The AC power adapter which is used to supply the DC power for the unit should have the AC voltage matching the commercial power voltage in your area.

The AC Power Adapter Specifications



AC input:	AC power voltage of your area - AC100V, 120V, 230V, 240V
DC output:	DC5V / DC7.5V / DC12V / DC24V
Power:	9W min.

Steps to apply the power to the product are:

1. Connect power adapter DC plug to the DC input jack located on the back of the unit before connecting to the AC outlet.
2. Connect the power adapter to the AC outlet.
3. Check Power LED indication.

Note: Before you begin the installation, check the AC voltage of your area. The AC power adapter which is

used to supply the DC power for the unit should have the AC voltage matching the commercial power voltage in your area.

2.5 Reset Button

The reset button is used to perform a reset of the switch. It is not used in normal cases and can be used for diagnostic purpose. If any network hanging problem is suspected, it is useful to push the button to reset the switch without turning off the power. Check whether the network has recovered.

The button can also be used to restore the software configuration settings to factory default values.

The operations are:

Operation	Function
Press the button and release	Reset & boot up the switch
Press and hold the button for more than 20 seconds and then release	Boot & restore all factory default settings

2.6 Making UTP Connections

The 10/100/1000 RJ-45 copper ports supports the following connection types and distances:

Network Cables

10BASE-T:	2-pair UTP Cat. 3,4,5 , EIA/TIA-568B 100-ohm
100BASE-TX:	2-pair UTP Cat. 5, EIA/TIA-568B 100-ohm
1000BASE-T:	4-pair UTP Cat. 5 or higher (Cat.5e is recommended), EIA/TIA-568B 100-ohm
Link distance:	Up to 100 meters

Auto MDI/MDI-X Function

This function allows the port to auto-detect the twisted-pair signals and adapts itself to form a valid MDI to MDI-X connection with the remote connected device automatically. No matter a straight through cable or crossover cable is connected, the ports can sense the receiving pair automatically and configure itself to match the rule for MDI to MDI-X connection. It simplifies the cable installation.

Auto-negotiation Function

The ports are featured with auto-negotiation function and full capability to support connection to any Ethernet devices. The port performs a negotiation process for the speed and duplex configuration with the connected device automatically when each time a link is being established. If the connected device is also auto-negotiation capable, both devices will come out the best configuration after negotiation process. If the connected device is incapable in auto-negotiation, the switch will sense the speed and use half duplex for the connection.

Port Configuration Management

For making proper connection to an auto-negotiation incapable device, it is suggested to use port control function via software management to set forced mode and specify speed and duplex mode which match the configuration used by the connected device.

2.7 Making Fiber Connection

The dual-speed SFP slot must be populated with a fiber optic SFP module for making a fiber connection.

Installing SFP Module

1. Turn off the power to the switch.
2. Insert the SFP module into the SFP slot.
3. Once the module is seated securely in the slot, place the bail in lock position.

Connecting Fiber Cables

LC connectors are commonly equipped on most SFP modules. Identify the TX and RX connector before making cable connection. The following figure illustrates a connection example between two fiber ports:

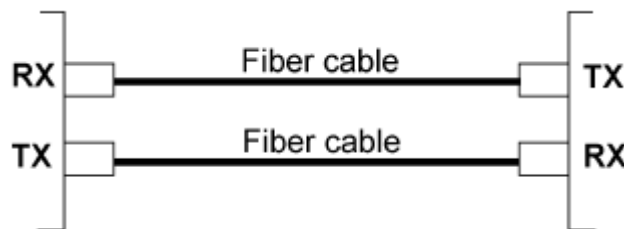

Make sure the Rx-to-Tx connection rule is followed on the both ends of the fiber cable.

Network Cables

Multimode (MMF) - 50/125, 62.5/125

Single mode (SMF) - 9/125

Port Speed Configuration

There are three options for configuring port speed via software for the SFP Port. The options are:

Port Mode	Description
Auto	Auto-detection for the type of the installed SFP transceiver by reading DDM data 100Mbps transceiver: Non-auto-negotiation (forced), 100Mbps, full duplex 1000Mbps transceiver: Auto-negotiation, 1000Mbps, full duplex
100Mbps FDX	Non-auto-negotiation (forced), 100Mbps, full duplex
1Gbps FDX	Auto-negotiation, 1000Mbps, full duplex

2.8 LED Indication

LED	Function	State	Interpretation
POWER	Power status	ON	The power is supplied to the switch.
		OFF	The power is not supplied to the switch.
LNK/1000M/ACT	Port link status	ON	A 1000M link is established. (No traffic)
		BLINK	Port link is up and there is traffic.
		OFF	Port link is down.
LNK/100M/ACT	Port link status	ON	A 100M link is established. (No traffic)
		BLINK	Port link is up and there is traffic.
		OFF	Port link is down.
LNK/10M/ACT	Port link status	ON	A 10M link is established. (No traffic)
		BLINK	Port link is up and there is traffic.
		OFF	Port link is down.
P6 1G	Port 6 1G link status	ON	A 1000Mbps link is established on Port 6.
		BLINK	Port 6 link is up and there is traffic.
		OFF	Port 6 link is down.
P6 100M	Port 6 100M link status	ON	A 100Mbps link is established on Port 6.
		BLINK	Port 6 link is up and there is traffic.
		OFF	Port 6 link is down.

3. Manage the Switch

The switch provides the following methods to configure and monitor the switch as follows:

- In-band management via web interface over TCP/IP network
- In-band management via telnet CLI over TCP/IP network
- In-band SNMP management over TCP/IP network

3.1 IP Address & Password

The IP Address is an identification of the switch in a TCP/IP network. Each switch should be designated a new and unique IP address in the network. The switch is shipped with the following factory default settings for software management:

Default IP address of the switch: **192.168.0.2 / 255.255.255.0**

The switch uses local authentication instead of RADIUS authentication with factory defaults.

Fixed Username: **admin**

Default password:

No password is required with factory default. However, the password is used for local authentication in accessing to the switch via telnet and Http web-based interface. For security reasons, it is recommended to change the default settings for the switch before deploying it to your network.

3.2 Configuring IP Address & Password via telnet

[IP Address] setting command is in IP command group.

```
>IP Setup [<ip_addr>] [<ip_mask>] [<ip_router>] [<vid>]
```

Parameters:

<ip_addr>	: IP address (a.b.c.d)
<ip_mask>	: IPv4 subnet mask (a.b.c.d)
<ip_router>	: IPv4 router (a.b.c.d)
<vid>	: VLAN ID (1-4095)

[IPv6 Address] setting command is also in IP command group.

```
>IP IPv6 Setup [<ipv6_addr>] [<ipv6_prefix>] [<ipv6_router>]
```

Parameters:

<ipv6_addr> : IPv6 address is in 128-bit records represented as eight fields of up to four hexadecimal digits with a colon separates each field (:).
<ipv6_prefix> : IPv6 subnet mask
<ipv6_router> : IPv6 router

[Password] setting command is also in Security/Switch/Users command group.

Security Switch Users Configuration

Security Switch Users Add <user_name> <password> <privilege_level>

Security Switch Users Delete <user_name>

Refer to “Operation manual for telnet management”.

3.3 Configuring IP Address via Web Interface

Start Web Browser

Start your browser software and enter the default IP address of the switch unit to which you want to connect. The IP address is used as URL for the browser software to search the device.

URL: <http://192.168.0.2/>

Login to Switch Unit

When browser software connects to the switch unit successfully, a Login screen is provided for you to login to the device as the left display below:



Enter Network Password

Please type your user name and password.

Site: 192.168.0.2

Realm: webstax_domain

User Name:

Password:

Save this password in your password list

OK Cancel

Enter the following default values in the login page:

Default username: **admin**

Default password: ↵

No password is required.

Click **OK** to login into the switch.

Web Page after a Successful Login

Select [Configuration] -> [System] -> [IP] to configure IP address

IP Configuration

	Configured	Current
DHCP Client	<input type="checkbox"/>	<input type="button" value="Renew"/>
IP Address	192.168.0.179	192.168.0.179
IP Mask	255.255.255.0	255.255.255.0
IP Router	0.0.0.0	0.0.0.0
VLAN ID	1	1
DNS Server	0.0.0.0	0.0.0.0

IP DNS Proxy Configuration

DNS Proxy

Configuration	Description
DHCP Client	Enable the DHCP client by checking this box.
IP Address	Provide the IP address of this switch unit.
IP Mask	Provide the IP mask of this switch unit.
IP Router	Provide the IP address of the default router for this switch unit.
VLAN ID	Provide the managed VLAN ID. The allowed range is 1 through 4095.

DNS Server	Provide the IP address of the DNS Server in dotted decimal notation.
DNS Proxy	When DNS proxy is enabled, DUT will relay DNS requests to the current configured DNS server on DUT, and reply as a DNS resolver to the client device on the network.

<input type="button" value="Save"/>	Click to save the changes.
<input type="button" value="Reset"/>	Click to undo any changes made locally and revert to previously saved values.
<input type="button" value="Renew"/>	Click to renew DHCP. This button is only available if DHCP is enabled.

3.4 Reference Manuals for Web and Telnet Management

Telnet and Web management manuals are also available if requested.

The manuals describe the detailed commands and information for the management features.

3.5 Configuration for SNMP Management

The switch supports SNMP v1, SNMP v2c, and SNMP v3 management. Make sure the related settings are well-configured for the switch before you start the SNMP management from an SNMP manager.

Using Telnet Interface

The following are available commands in telnet SNMP command group to configure SNMP-related settings:

```
>SNMP Configuration
>SNMP Mode [enable|disable]
>SNMP Version [1|2c|3]
>SNMP Read Community [<community>]
>SNMP Write Community [<community>]
>SNMP Trap Mode [enable|disable]
>SNMP Trap Version [1|2c|3]
>SNMP Trap Community [<community>]
>SNMP Trap Destination [<ip_addr_string>]
>SNMP Trap IPv6 Destination [<ipv6_addr>]
>SNMP Trap Authentication Failure [enable|disable]
>SNMP Trap Link-up [enable|disable]
>SNMP Trap Inform Mode [enable|disable]
>SNMP Trap Inform Timeout [<timeout>]
>SNMP Trap Inform Retry Times [<retries>]
>SNMP Trap Probe Security Engine ID [enable|disable]
>SNMP Trap Security Engine ID [<engineid>]
>SNMP Trap Security Name [<security_name>]
>SNMP Engine ID [<engineid>]
>SNMP Community Add <community> [<ip_addr>] [<ip_mask>]
>SNMP Community Delete <index>
>SNMP Community Lookup [<index>]
>SNMP User Add <engineid> <user_name> [MD5|SHA] [<auth_password>] [DES] [<priv_password>]
>SNMP User Delete <index>
>SNMP User Changekey <engineid> <user_name> <auth_password> [<priv_password>]
>SNMP User Lookup [<index>]
>SNMP Group Add <security_model> <security_name> <group_name>
>SNMP Group Delete <index>
>SNMP Group Lookup [<index>]
>SNMP View Add <view_name> [included|excluded] <oid_subtree>
```

>SNMP View Delete <index>

>SNMP View Lookup [<index>]

>SNMP Access Add <group_name> <security_model> <security_level> [<read_view_name>] [<write_view_name>]

>SNMP Access Delete <index>

>SNMP Access Lookup [<index>]

Using Web Interface

Select [Configuration] -> [Security] -> [SNMP]:



The commands support configuration for:

- Basic system configuration for SNMP v1 and SNMP v2c
- Basic system configuration for SNMP v1 trap, SNMP v2c trap and SNMP v3 trap
- Communities that permit to access to SNMPv3 agent
- USM (User-based Security Model) user table for SNMPv3
- VACM (View-based Access Control Model) Viewer table for SNMPv3
- Group table for SNMPv3
- Accesses group table for SNMPv3

3.6 SNMP MIBs

The switch provides the following SNMP MIBs:

- RFC 1213 - MIB II
- RFC 2674 - QBridge MIB (VLAN MIB)
- RFC 2819 - RMON (Group 1, 2, 3 & 9)
- RFC 2863 - Interface Group (IF) MIB
- RFC 3411 - SNMP Management Frameworks
- RFC 3414 - User Based Security Model (USM)
- RFC 3415 - View Based Access Control Model (VACM)
- RFC 3621 - Power Ethernet MIB
- RFC 3635 - EtherLike MIB
- RFC 3636 - 802.3 Medium Attachment Units (MAUs) MIB
- RFC 4133 - Entity MIB

- RFC 4188 - Bridge MIB
- RFC 4668 - RADIUS Authentication Client MIB
- RFC 5519 - Multicast Group Membership Discovery (MGMD) MIB
- IEEE 802.1 MSTP MIB
- IEEE 802.1AB LLDP MIB
- IEEE 802.1X Port Access Entity (PAE) MIB
- TIA 1057 LLDP Media Endpoint Discovery (MED) MIB
- IEEE 802.1-Q-BRIDGE MIB
- Private SFPDDM MIB (Read DDM status of the SFP ports)
- Private reboot MIB (Remote boot over SNMP)
- Private TFTP firmware update MIB (TFTP Firmware update over SNMP)
- Private OPA function MIB (OPA configuration for the SFP ports)
- Private ALS function MIB (ALS configuration for the SFP ports)

One product MIB file is also available in the product CD for SNMP manager software.

3.6.1 SNMP Traps

In addition to the SNMP standard traps, the device is equipped with private OPA alarm traps.

The traps are:

- Alarm trap – SFP port TX power lower than the minimal value
- Alarm trap – SFP port TX power higher than the maximal value
- Normal trap – SFP port TX power back to normal (higher than the minimal value)
- Normal trap – SFP port TX power back to normal (lower than the maximal value)