

PrismXR Carina W1  
P1101  
User Manual  
Rev1.0  
10/08/2023

# Support

For more information, please visit [www.prismxr.com/pages/support](http://www.prismxr.com/pages/support)

# Contents

1. What's In the Box .....	1
2. Product Introduction .....	2
3. How to Assemble .....	4
4. How to Wear .....	5
5. How to Set Up the Cord Organizer .....	6
6. Check the Battery Status of the Carina W1 .....	7
7. Charging Your VR Headset Using Carina W1 .....	8
8. Charging the Carina W1 .....	10
9. Clean the Carina W1 .....	11
10. Specifications .....	12
11. Safety Instructions .....	13
12. Warranty .....	15
13. FCC Statement .....	16

# 1. What's In the Box

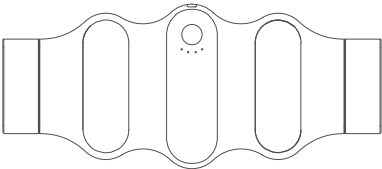

Carina W1



Left Strap



Right Strap



Cord Organizer

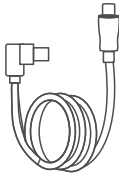

UCB-C Cable



## **2. Product Introduction**

The PrismXR Carina W1 is a powerful 10,000mAh power bank specially designed for charging VR headsets. With a power output of maximum 30W, it ensures efficient charging. Its waist-worn design eliminates the burden on the user's head during use. For convenience and comfort, it can be worn around the waist or across the shoulder. Additionally, it offers broad compatibility with all USB Type-C devices, adhering to USB charging standards.

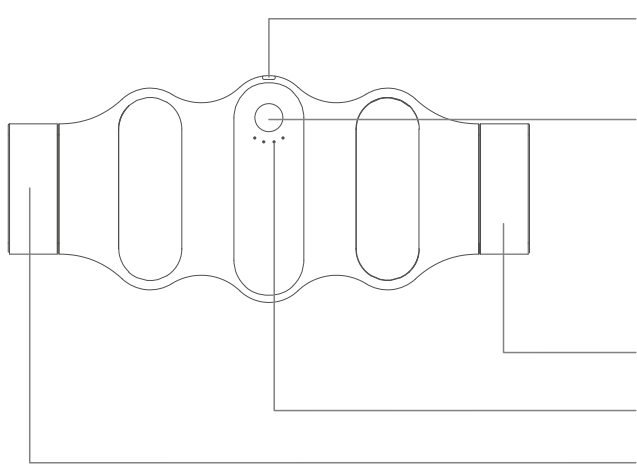

USB-C Charging Port

- Used for charging other devices and charging the Carina W1 itself.

Power Button

- Press once: Check the battery status of the Carina W1 or turn on Carina W1 again and continue charging your VR headset when it is turned off.
- Hold for 3 seconds: Turn off the Carina W1 and stop charging the VR headset.

Right Fixed Loop

LED Indicator

Left Fixed Loop

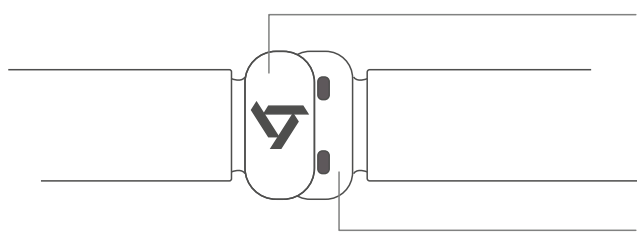

Magnet Buckle of the Right Strap

Magnet Buckle of the Left Strap

### 3. How to Assemble

- ① Take the left strap and thread it through the bottom of the left fixed loop of the Carina W1.
- ② Fold the left strap over and insert it into the top of the left fixed loop on the inner side.
- ③ Follow steps 1 and 2 to assemble the right strap in the same manner.

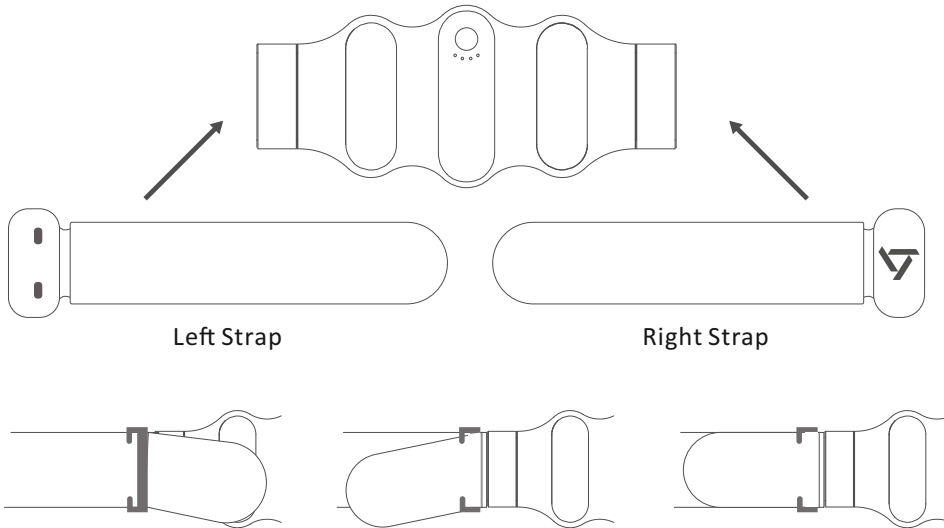

## 4. How to Wear

① There are two ways to wear the Carina W1:

- a Around the waist.
- b Across the shoulder.

② Fasten and unfasten the left and right straps using the magnetic buckle.

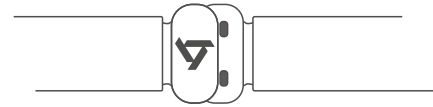
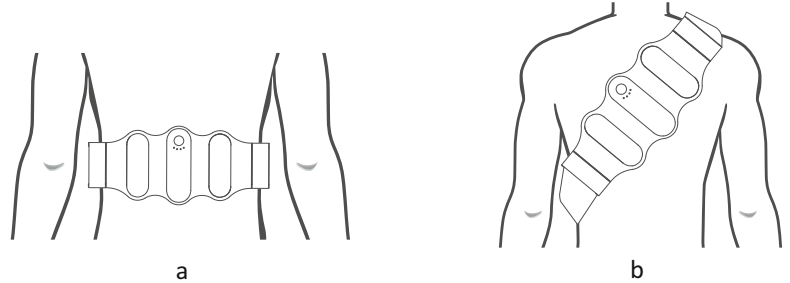

❗ During the wearing process, you may need to adjust the length of the strap to a suitable size.

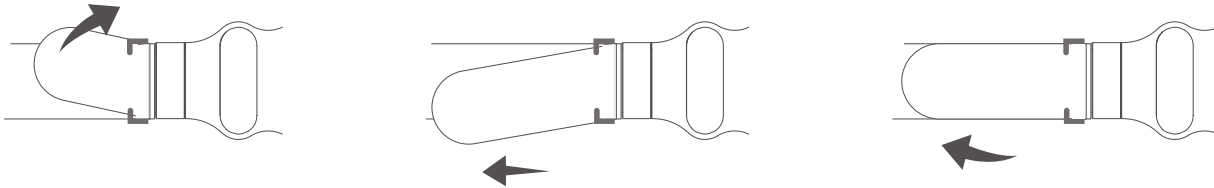

## 5. How to Set Up the Cord Organizer

- ① Remove the transparent sticker from the back of the cord organizer.
- ② Attach the cord organizer to the center of the headband on the back of the VR headset.

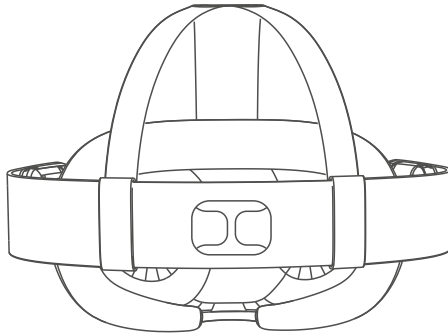

## 6. Check the Battery Status of the Carina W1

- ❗ It is recommended that you press the power button to check the remaining power status of the Carina W1 before use.
- Press the Power button once, the four LED indicators and the corresponding battery charge levels are as shown in the image.

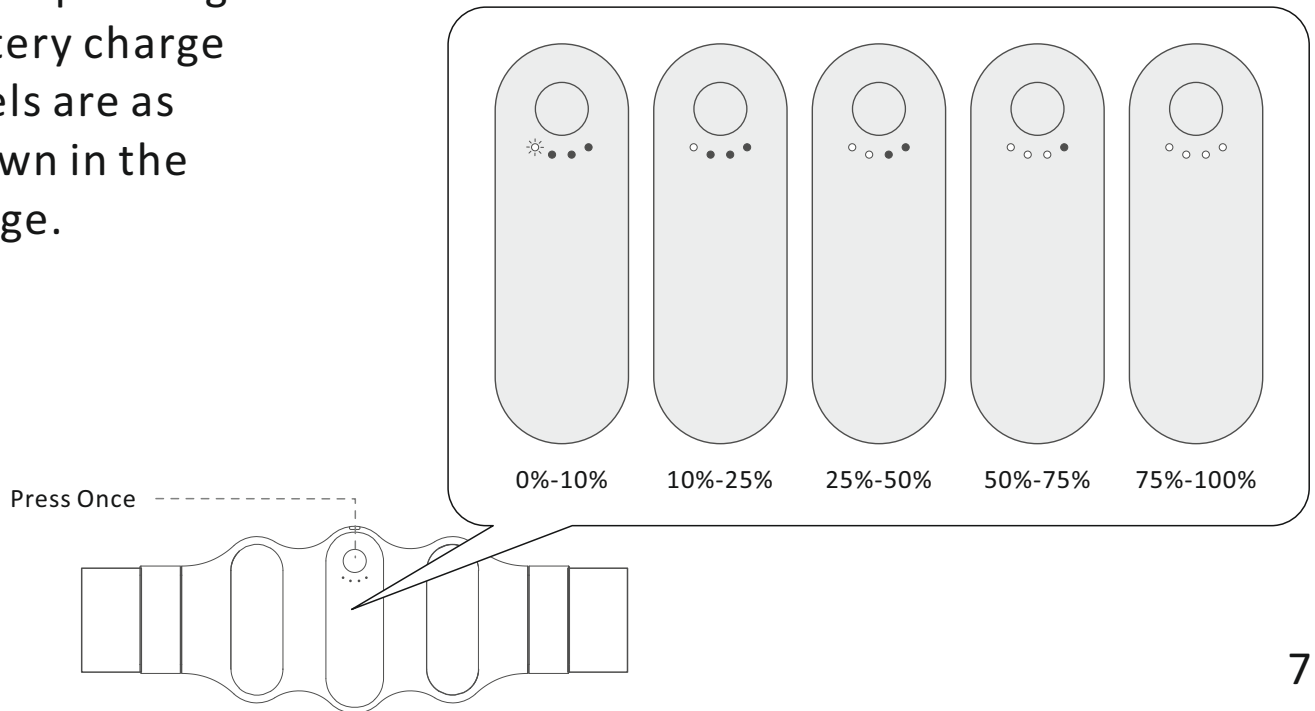

## 7. Charging Your VR Headset Using Carina W1

- ❗ When your VR headset is fully charged by the Carina W1, the Carina W1 will automatically turn off and stop charging.
- ❗ Press and hold the Power button for 3 seconds to turn off the Carina W1 and stop charging the VR headset. And press the Power button once to turn on Carina W1 again and continue charging your VR headset.
- ① Insert the USB-C charging cable into the Carina W1.
- ② Insert the L-shaped USB-C connector of the charging cable into VR headset, Carina W1 will automatically turn on and charge your VR headset.
- ③ Thread the charging cable through the cord organizer and secure it at the back.
- ④ Put on your Carina W1.

1

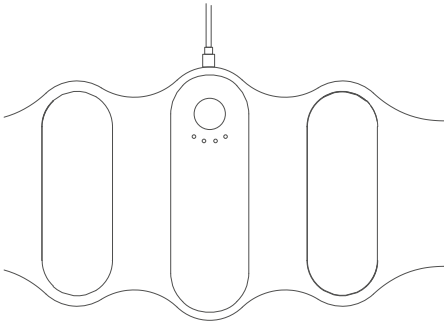

2

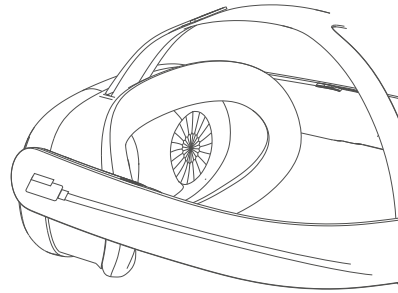

3

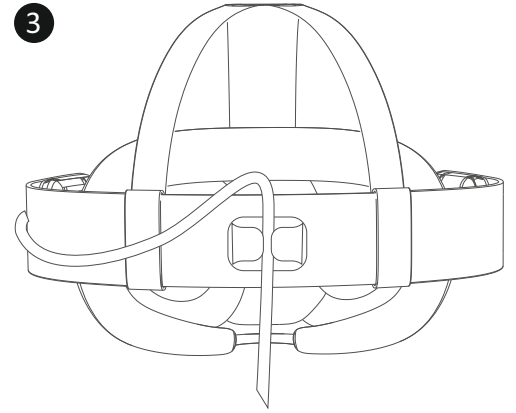

4

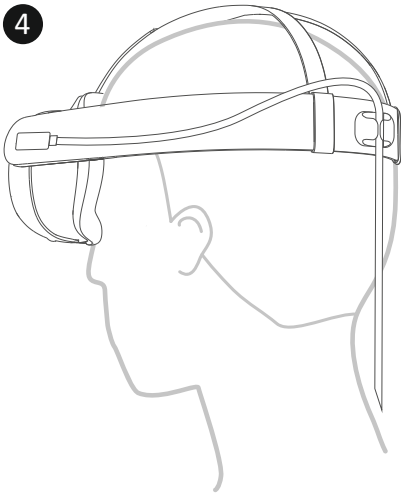

! If you find the charging cable too long, you can adjust its length using the reusable cable tie provided.

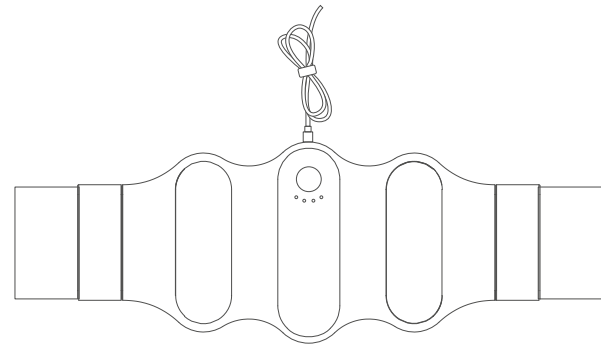



## 8. Charging the Carina W1

- ❗ After the Carina W1 is fully charged, the four LED indicators will turn off.
  - ❗ To charge the Carina W1, you will need to use an adapter(not provided). The maximum supported charging power is 18W, and it is compatible with input such as 5V/3A, 9V/2A, 12V/1.5A, etc.
- 1 Connect the Carina W1 to the power adapter.
  - 2 The four LED indicators and the corresponding battery charge levels are as shown in the image.

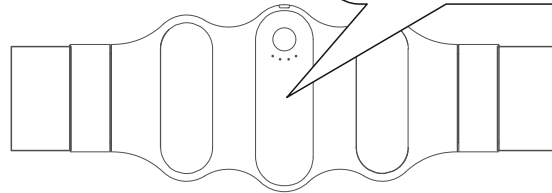
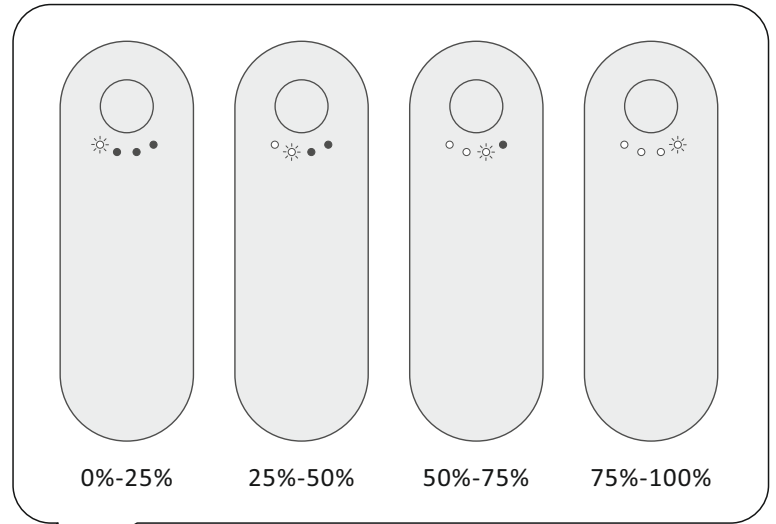

## 9. Clean the Carina W1

- ❗ Do not use washing machines or dryers.
- ❗ Make sure the liquid is alcohol free.
- ① Take off the left and right straps from Carina W1.

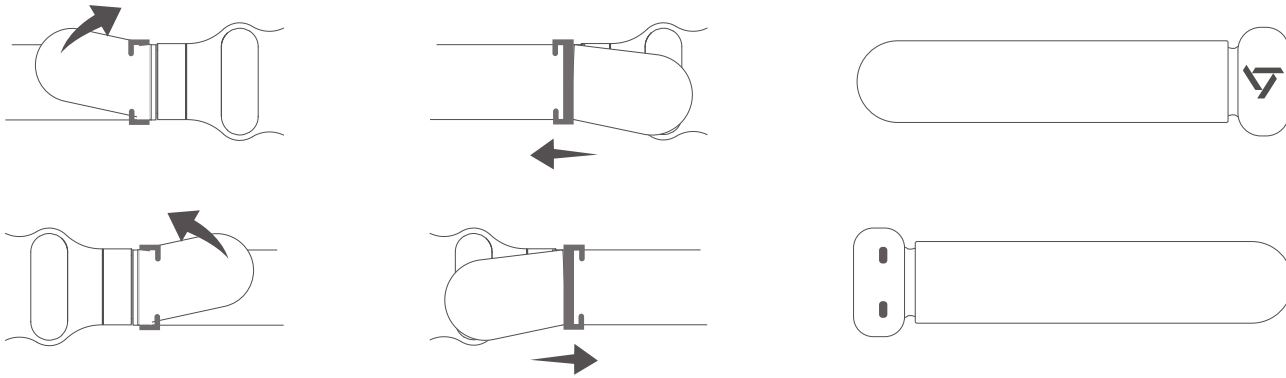

- ② Hand wash the two straps in clean water.
- ③ Allow the two straps to air dry naturally (do not wring them by hand).
- ④ Put them back after they are fully dry.

# 10. Specifications

! Specifications are subject to change without notice.

<b>Battery Capacity</b>	5000mAh 7.3V/36.5Wh
<b>Cell</b>	5000mAh*2pcs
<b>Input</b>	5V=3A, 9V=2A, 12V=1.5A max
<b>Output</b>	5V=2A, 5V=3A, 9V=2A, 9V=3A, 12V=2.5A (30W max)
<b>Environment</b>	Operating Temperature: 0°C~45°C (32°F ~113°F) Storage Temperature: -40°C~70°C (-40°F ~158°F) Operating Humidity: 10%~90% non-condensing Storage Humidity: 5%~90% non-condensing
<b>Dimensions (W×D×H)</b>	Standard: 38 x 4.25 x 1.08in (965 x 108 x 27.46mm) Small: 30 x 4.25 x 1.08in (762 x 108 x 27.46mm)

# 11. Safety Instructions

When using this product, basic precautions should always be followed, including the following:

- Clean the Carina W1 with a soft, dry cloth. Make sure the liquid is alcohol free.
- You can take off the straps and wash them (do not use washing machines or dryers). Put them back after they are fully dry.
- Carina W1 is not waterproof and should not be rinsed under running water or submerged in an ultrasonic cleaner.
- Store product in a cool and dry place.
- Do not store the product in a hot or humid environment.
- The operating temperature should be between 0°C to 45°C.
- Do not disassemble the product. Take it to a qualified service person when service or repair is required. Incorrect reassembly may result in a risk of fire or injury to persons.

- If the product is not used for long periods of time, you should change and discharge it once every three months.
- When charging a device, the front side of the product may feel warm. This is a normal operating condition and should not be cause of concern.
- In normal conditions, the battery performance will decline over several years.
- Do not dispose of the product in heat or fire.
- Do not clean the product with harmful chemicals or detergents.
- Misuse, dropping or excessive force may cause product damage.
- When disposing of secondary cells or batteries, keep cells or batteries of different electrochemical systems separate from each other. Before disposal, cover the battery connector with electrical insulating tape.

## 12. Warranty

If you have any difficulties using your PrismXR Carina W1, please contact us

Email: [customerservice@prismxr.io](mailto:customerservice@prismxr.io)

**PRISMXR PTE LTD** 60 PAYA LEBAR ROAD #12-03 PAYA LEBAR SQUARE, 409051

### **Warranty 18 months Limited Electrical Warranty**

PrismXR warrants to the original residential user of this product that it will be free from defects in materials and workmanship, under normal use, for 18 months from the date of purchase. User must provide a copy of original purchase receipt. This warranty does not cover abuse or misused products or products used in commercial applications. This warranty does not apply to PrismXR Carina W1 that have been improperly installed, modified, put to a use other than designed, or subjected to acts of God (such as floods, lightning, earthquakes, etc.). This warranty is limited to repair or replacement of the PrismXR Carina W1 only at PrismXR's sole discretion. PrismXR will NOT be liable for the cost of installing, removing, nor reinstalling this product, nor direct, indirect, or consequential damages to persons or property resulting from the use of this product. This warranty only covers the cost of replacement parts or replacement units, it does not cover shipping & handling fees.

To implement this warranty, please visit [www.prismxr.com/pages/support](http://www.prismxr.com/pages/support)

# 13. FCC Statement

This device complies with Part 15 of the FCC Rules. Operation is subject to the following two conditions: (1) This device may not cause harmful interference, and (2) this device must accept any interference received, including interference that may cause undesired operation.

**Warning:** Changes or modifications not expressly approved by the party responsible for compliance could void the user's authority to operate the equipment.

**Note:** This equipment has been tested and found to comply with the limits for a Class B digital device, pursuant to Part 15 of the FCC Rules. These limits are designed to provide reasonable protection against harmful interference in a residential installation. This equipment generates, uses, and can radiate radio frequency energy and, if not installed and used in accordance with the instructions, may cause harmful interference to radio communications. However, there is no guarantee that interference will not occur in a particular installation. If this equipment does cause harmful interference to radio or television reception, which can be determined by turning the equipment off and on, the user is encouraged to try to correct the interference by one or more of the following measures:

- (1) Reorient or relocate the receiving antenna.
- (2) Increase the separation between the equipment and receiver.
- (3) Connect the equipment into an outlet on a circuit different from that to which the receiver is connected.
- (4) Consult the dealer or an experienced radio/TV technician for help.

The following importer is the responsible party.

Company Name: PRISM XR PTE, LTD

Address: 60 PAYA LEBAR ROAD #12-03 PAYA LEBAR SQUARE SINGAPORE, 409051