

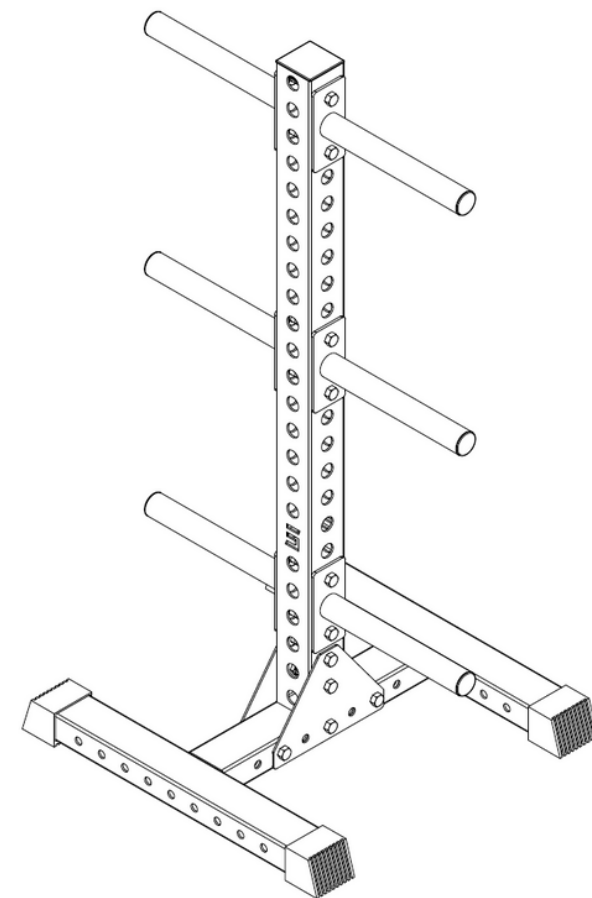

CONGRATULATIONS ON YOUR NEW PURCHASE

WELCOME TO THE SYNERGY FAMILY!
We know you need support, so we're here for you



We are here to support you in any way we can. Scan the QR code for options on how to best contact us or visit us at



<https://www.synergycustomfitness.com>



You can also email us support@synergycustomfitness.com or call us at 1-877-305-4057

*scan QR code for options
on how to contact us*



INSIDE THE BOX

Model #
PL-RK3

A (1) Upper tube

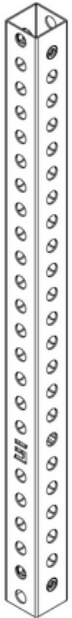

C (6) Weight Plate Holder

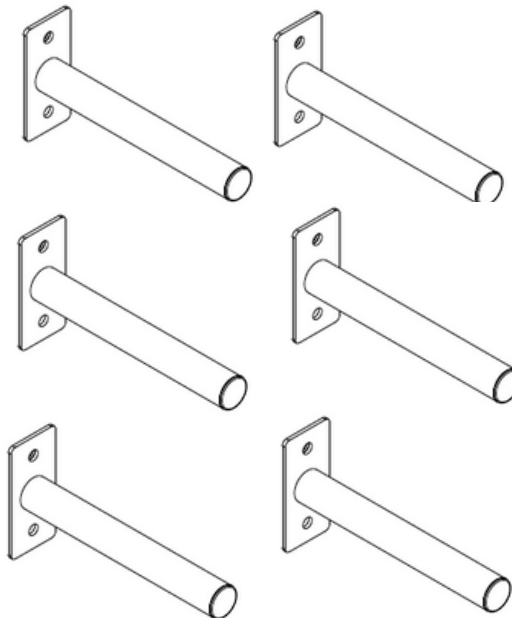

E (2) 1" bolts



F (10) 4" bolts

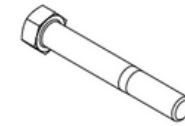

G (1) Box wrench

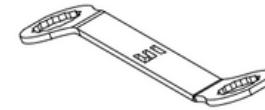

H (10) 1/2" hex nuts

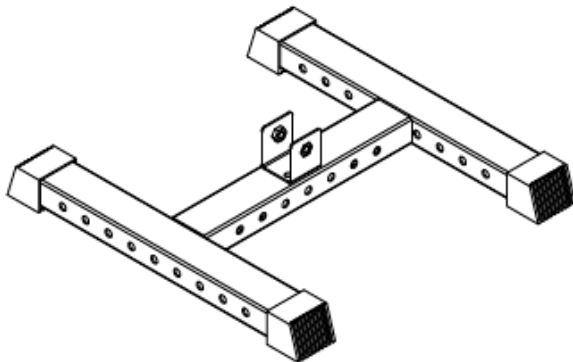

B (1) Leg base

D (2) Plate Support Plates

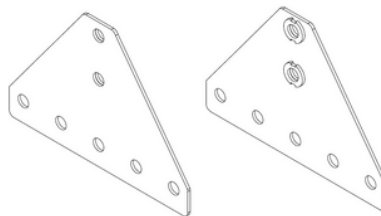

STEP 1

Model #
PL-RK3

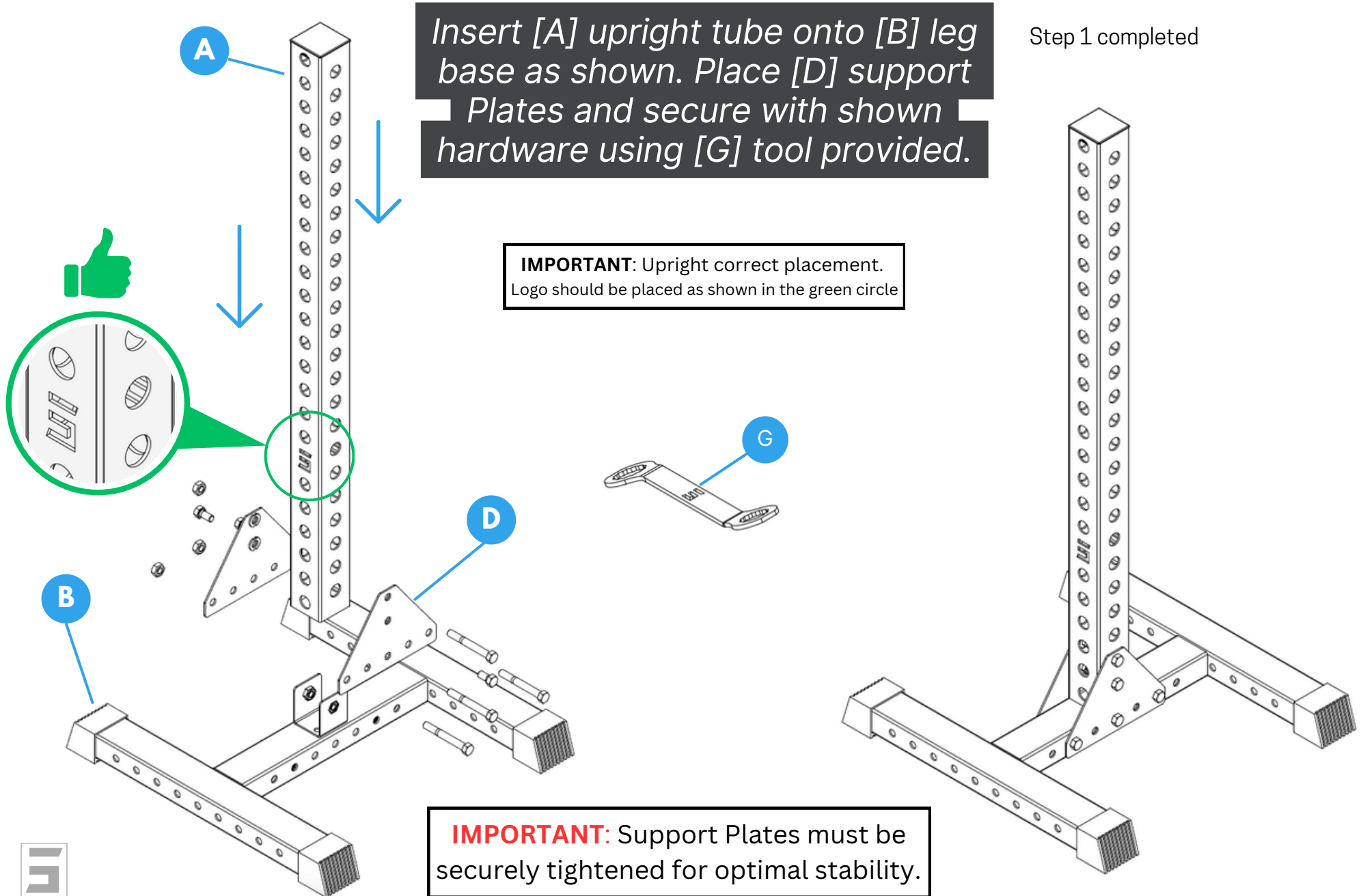

STEP 2

Model #
PL-RK3

Place [C] weight plate holders as shown using hardware provided. Use [G] wrench to securely tight [F] bolts using (H) hex nut.

Step 2 completed

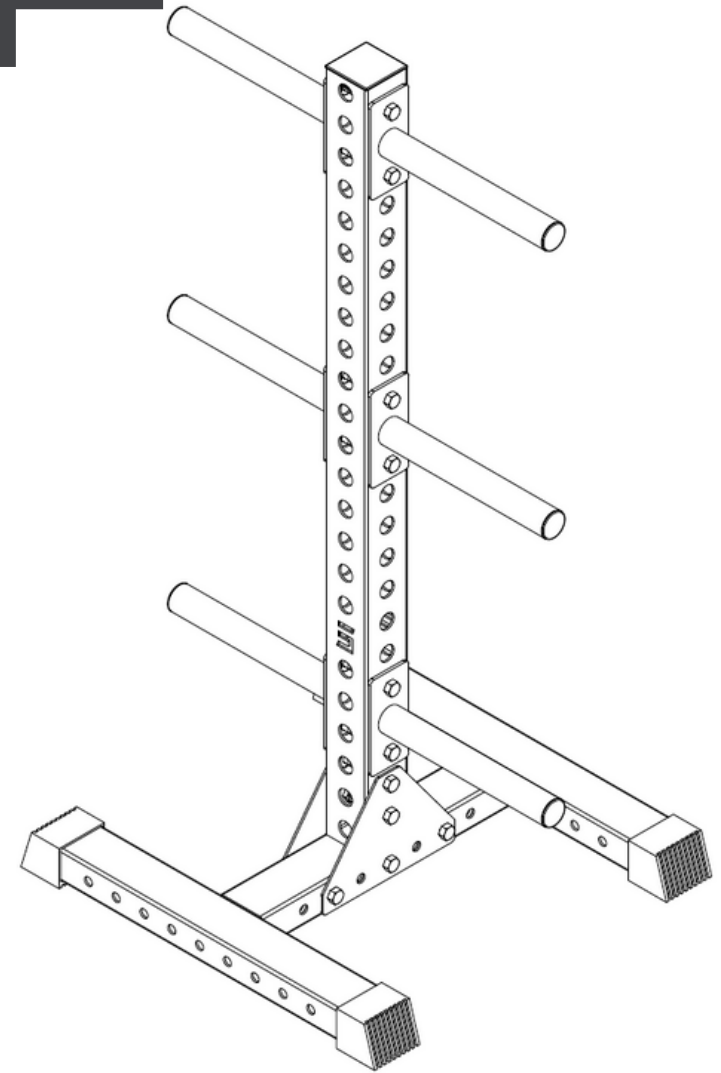
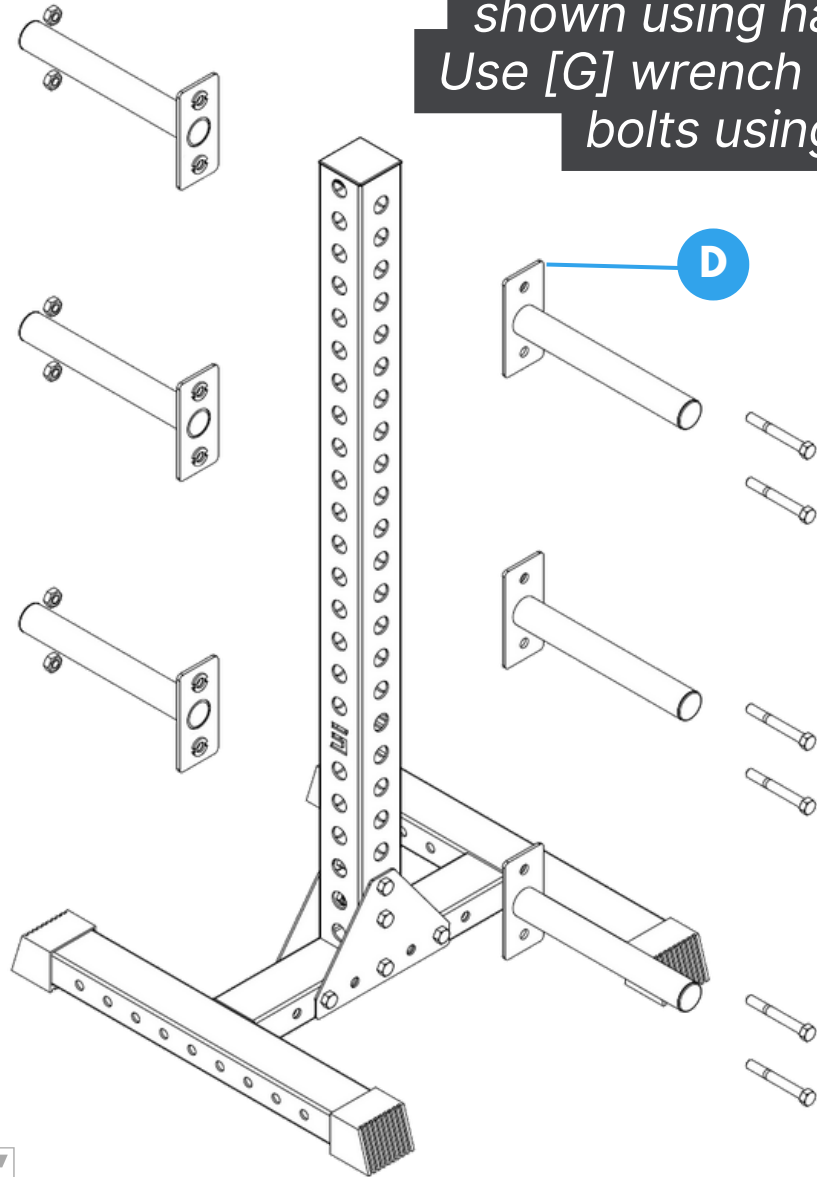

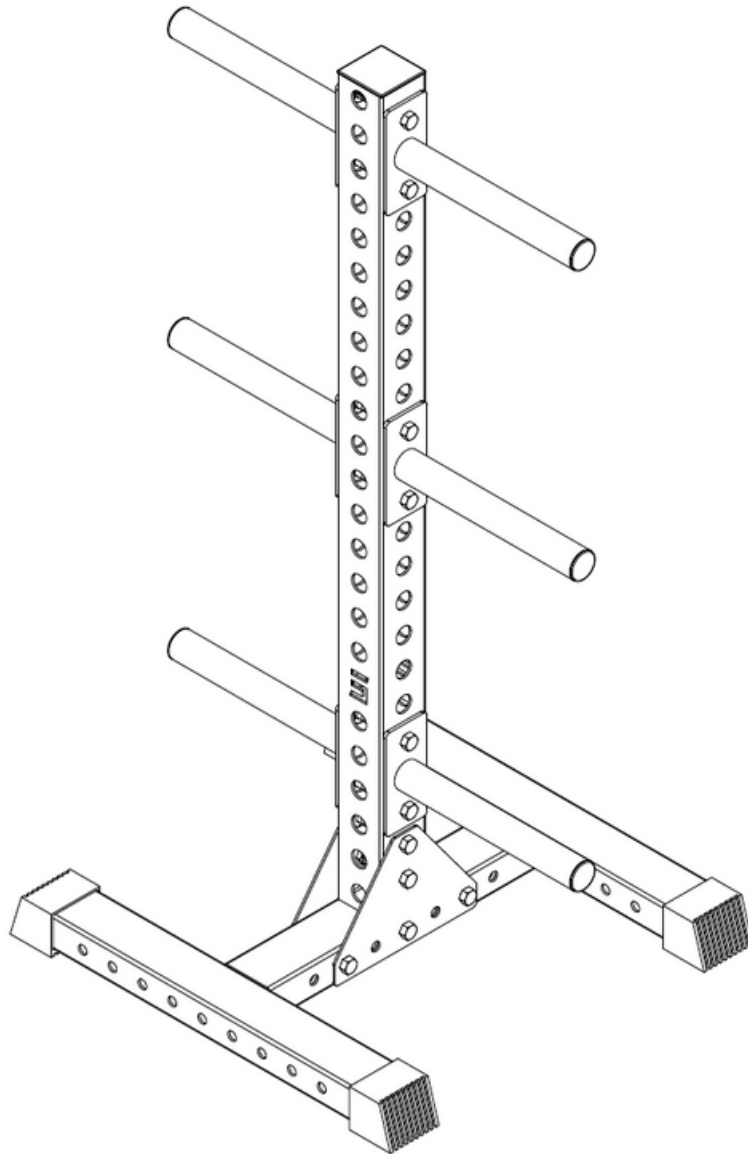

Wasn't that easy?

**You have assembled your new
dumbbell rack and didn't
even break a sweat.**

Now go brag about it in social media
and get your workout done!



NEED SUPPORT?

VISIT US ONLINE!

Contact us.



We are here to support you in any way we can. Scan the QR code for options on how to best contact us or visit us at



<https://www.synergycustomfitness.com>



You can also email us support@synergycustomfitness.com or call us at 1-877-305-4057

scan QR code to
visit us online



WARNINGS



Heavy Object.

Use lifting aids and proper lifting techniques when moving to avoid injury.



Sharp Objects.

Sharp objects may be included. Always use precaution and protection to avoid injury.



Choking Hazard.

Small parts – Please exercise caution if small children or pets are present.



Suffocation Hazard.

Plastic bags may be involved. Please exercise caution by keeping bags away from babies, small children and pets.