

ASSEMBLY INSTRUCTIONS

Model #
H-DBRK-ALP



CONGRATULATIONS ON YOUR NEW PURCHASE

WELCOME TO THE SYNERGY FAMILY!
Do you need support? we are here for you

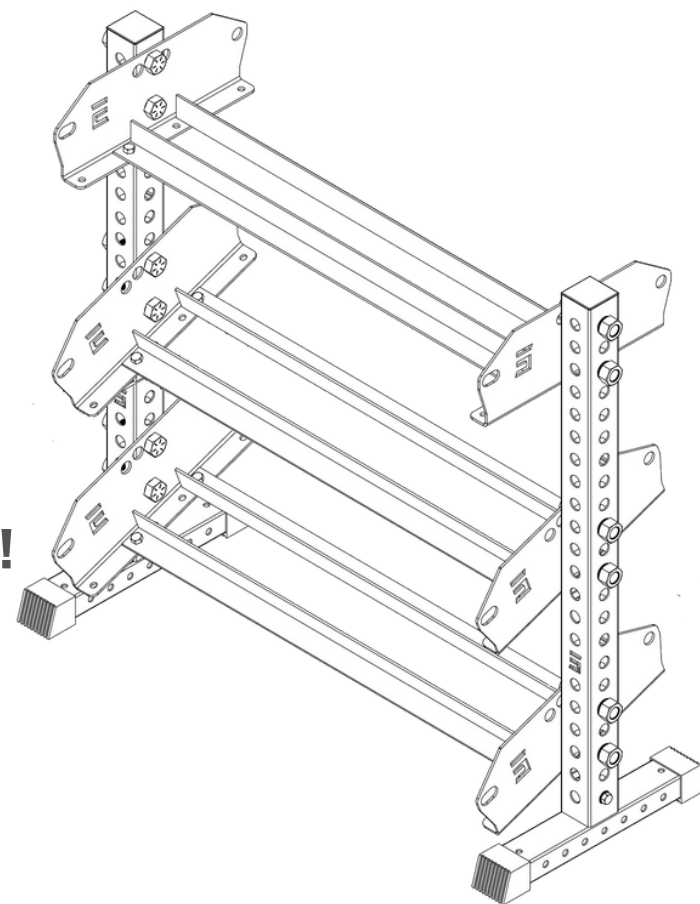

We are here to support you in any way we can. Scan the QR code for options on how to best contact us or visit us at



<https://www.synergycustomfitness.com>



You can also email us support@synergycustomfitness.com or call us at 1-877-305-4057

scan QR code for options
on how to contact us



INSIDE THE BOX

Model #

3- Tier Horizontal Storage Alpha H-DBRK-ALP

A (2) Upper tubes

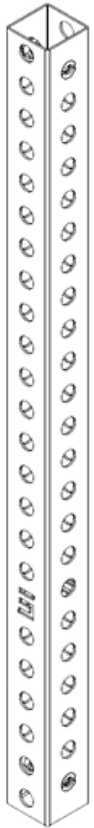

O (2) Base support Plates

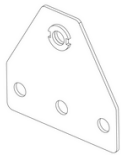

B (2) Leg base

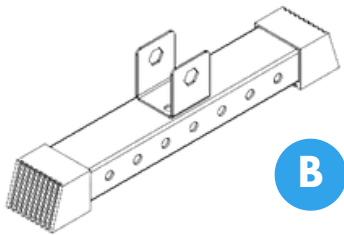

C (6) L Angle Shelf Support

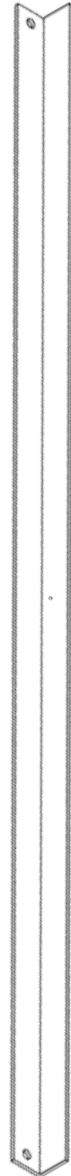

D (6) Shelf Brackets

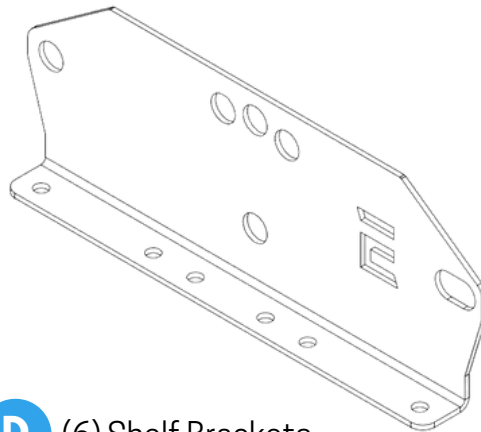

E (1) Small wrench



F (12) 4.3/4" - 1" Bolt



G (24) 1" Nylon washer



H (12) 1" lock washer



I (12) 1" hex nut



J (16) 1" - 1/2" bolt



K (4) 1/2 specialty washer



L (4) 1/2 flat washer



M (16) 1/2 hex nut



N (4) 4" - 1/2" bolt



*Additional 1 3/8 wrench tool needed but not included

STEP 1

Model #
H-DBRK-ALP

WARNING: Many of these parts are heavy and could cause serious injury if not handle properly, to help avoid injury we recommend assembling with another person and using proper tools,

1

Place [A] upright tube onto [B] leg base and use hardware [J] [L] [K] [M] and [N] to secure leg using [O] base support plate as shown.
NOTE: there are only 2 base support plates. Place in the inside of each leg as shown.
Repeat for second leg
DO NOT FULLY TIGHTEN YET

Step 1 completed

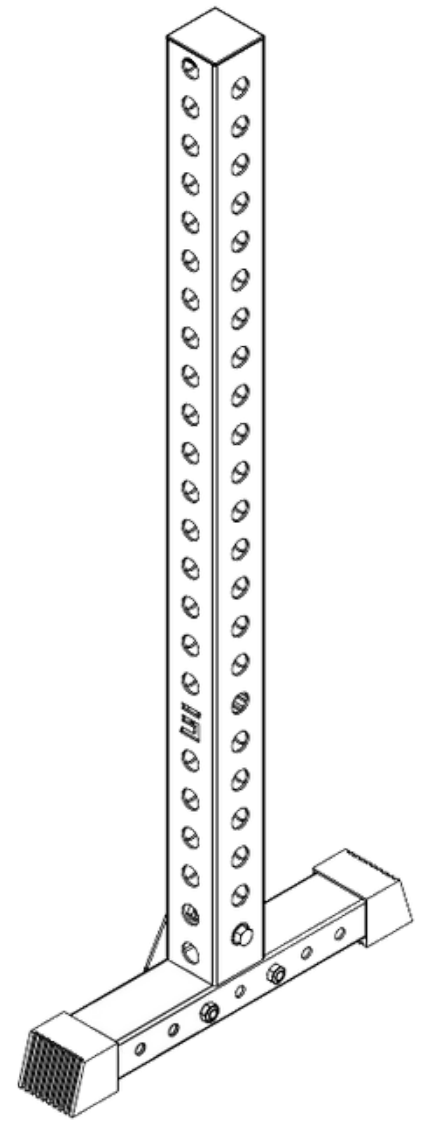
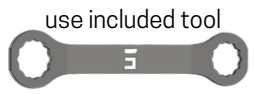
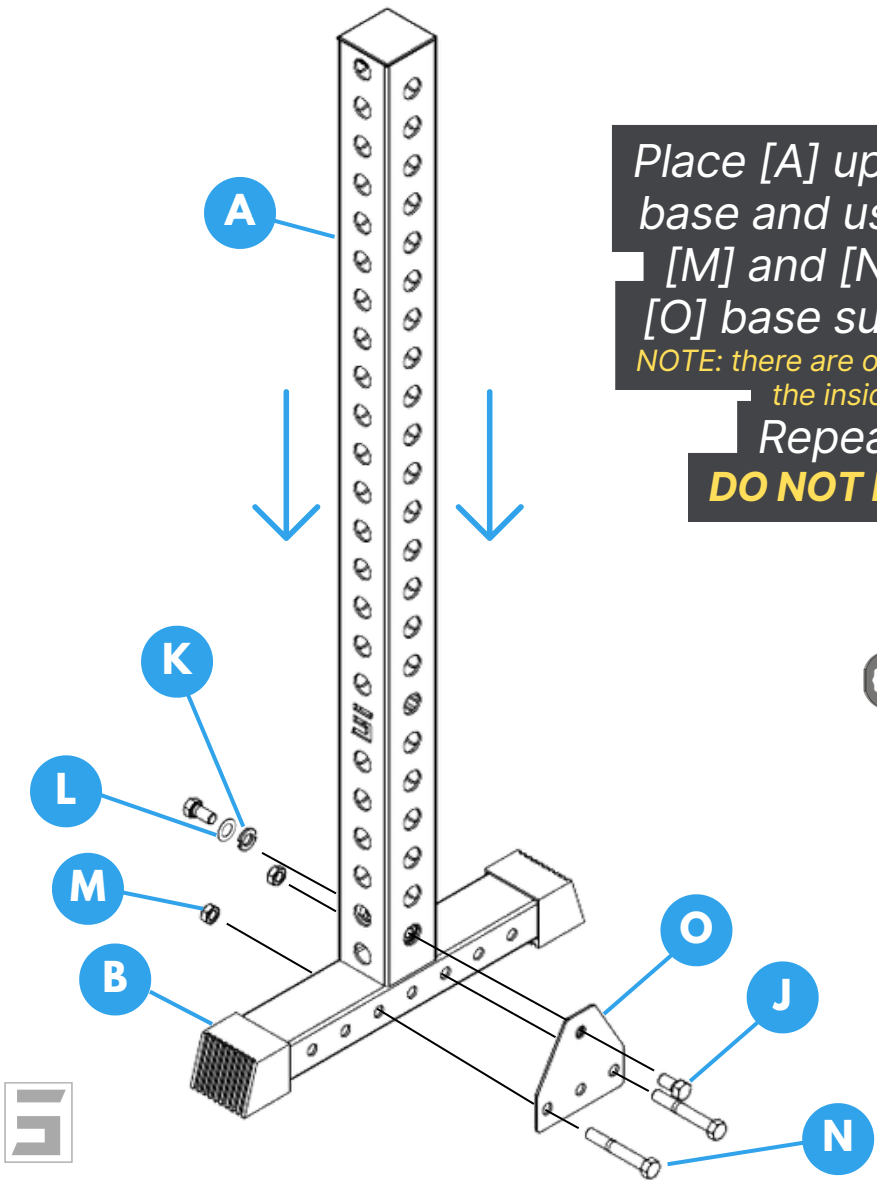

STEP 2

Model #
H-DBRK-ALP

2

Insert hardware [F] [G] [H] [I] as illustrated to secure shelf bracket [D] top upright support plate onto [B] upright tube. Repeat for second leg. **DO NOT FULLY TIGHTEN YET**

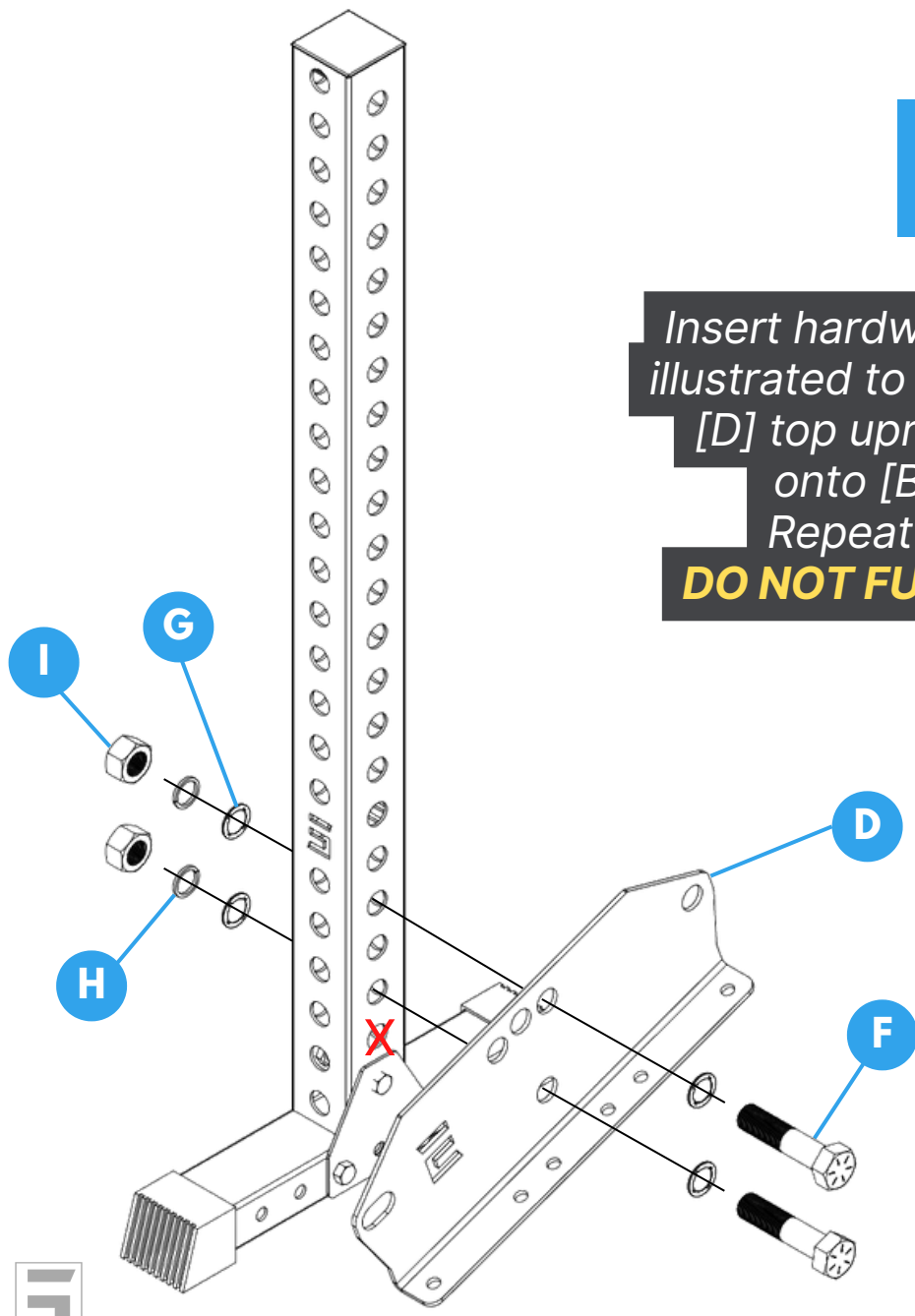

Step 2 completed

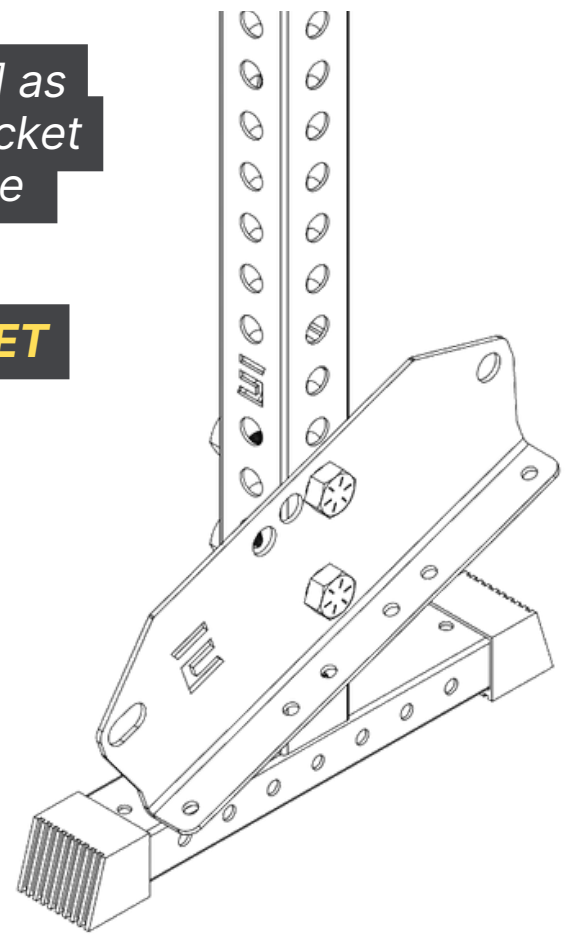

*We recommend setting up the first tier below before installing the higher tiers brackets

STEP 3

Model #
H-DBRK-ALP

3

Place both L Angle Shelf Support [C] on shelf brackets [D] and use hardware [J] and [M] to secure.
Repeat steps 2 and 3 for next tier on desire height.

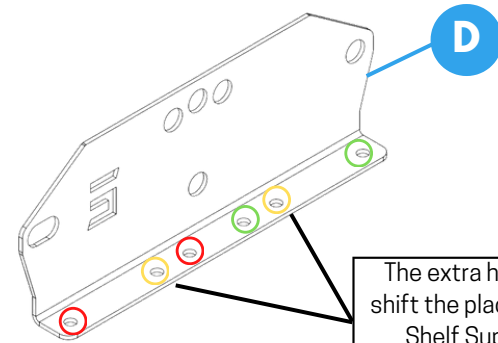

The extra holes will allow you to shift the placement of the L Angle Shelf Support when use for dumbbells. They can be staggered giving you three different positions **Forward, Center and Back**

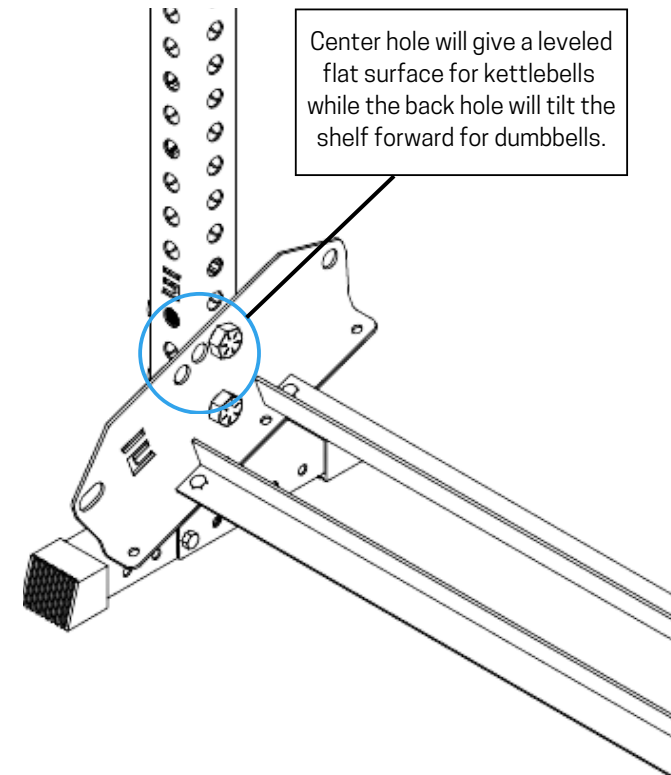
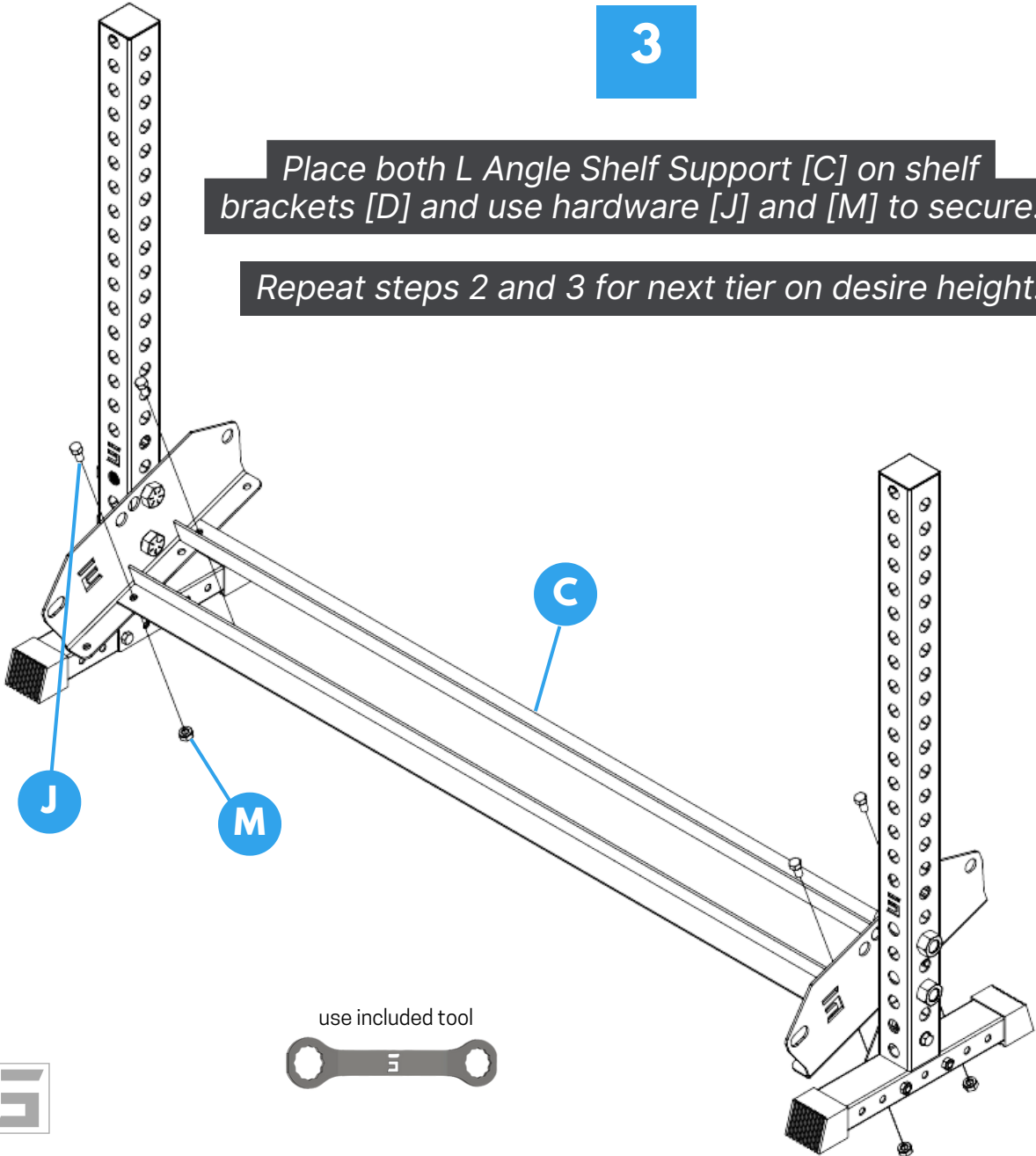

Center hole will give a leveled flat surface for kettlebells while the back hole will tilt the shelf forward for dumbbells.

use included tool



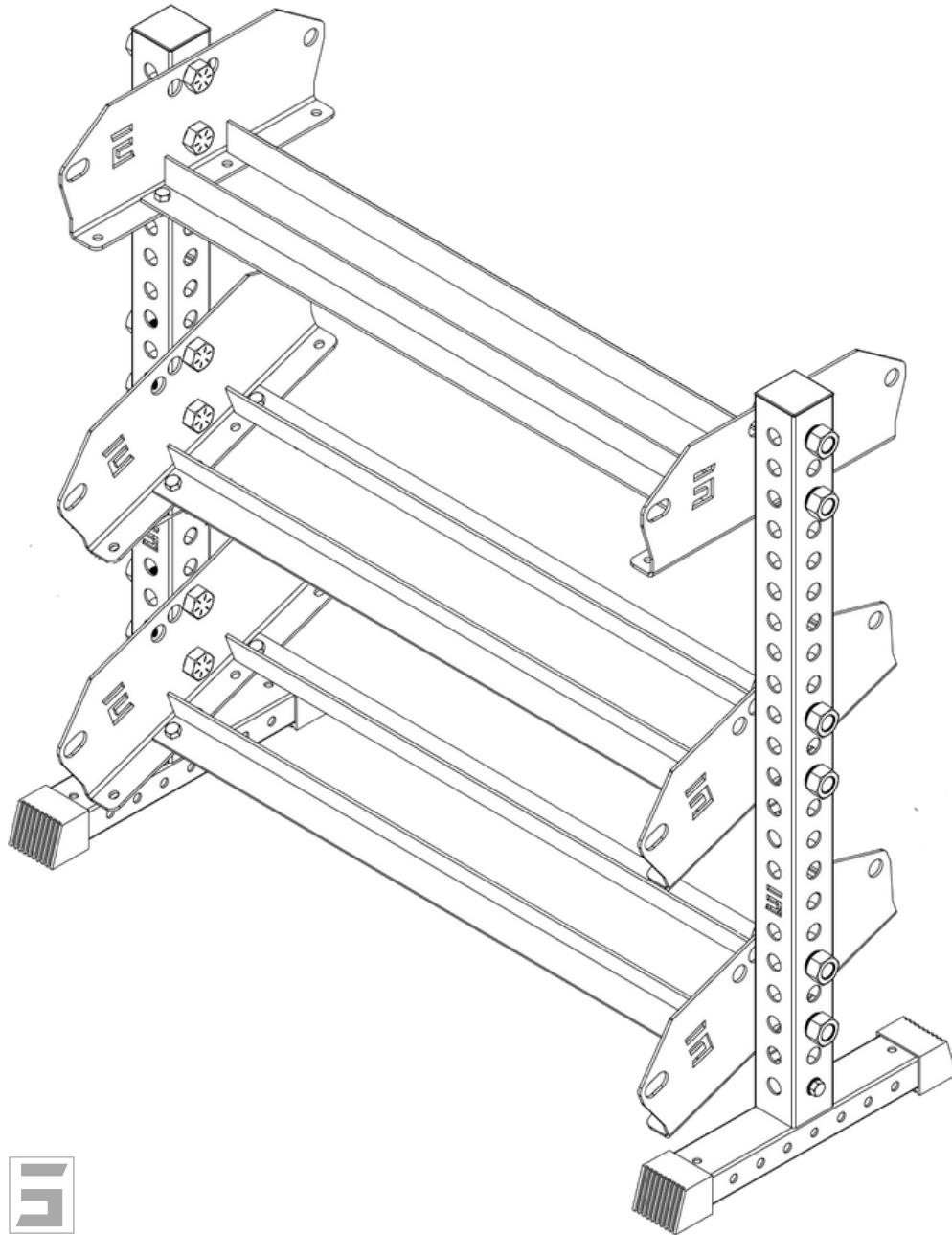

IMPORTANT

I DO NOT HAVE ADDITIONAL ACCESSORIES
then now is the time to make sure all hardware is securely fastened before adding any weights to it.

WAIT... I DO HAVE ADDITIONAL ACCESSORIES
If you have additional accessories to attach to this unit then **DO NOT FULLY TIGHTEN** until all accessories are attached.
See assembly instructions for additional accessories



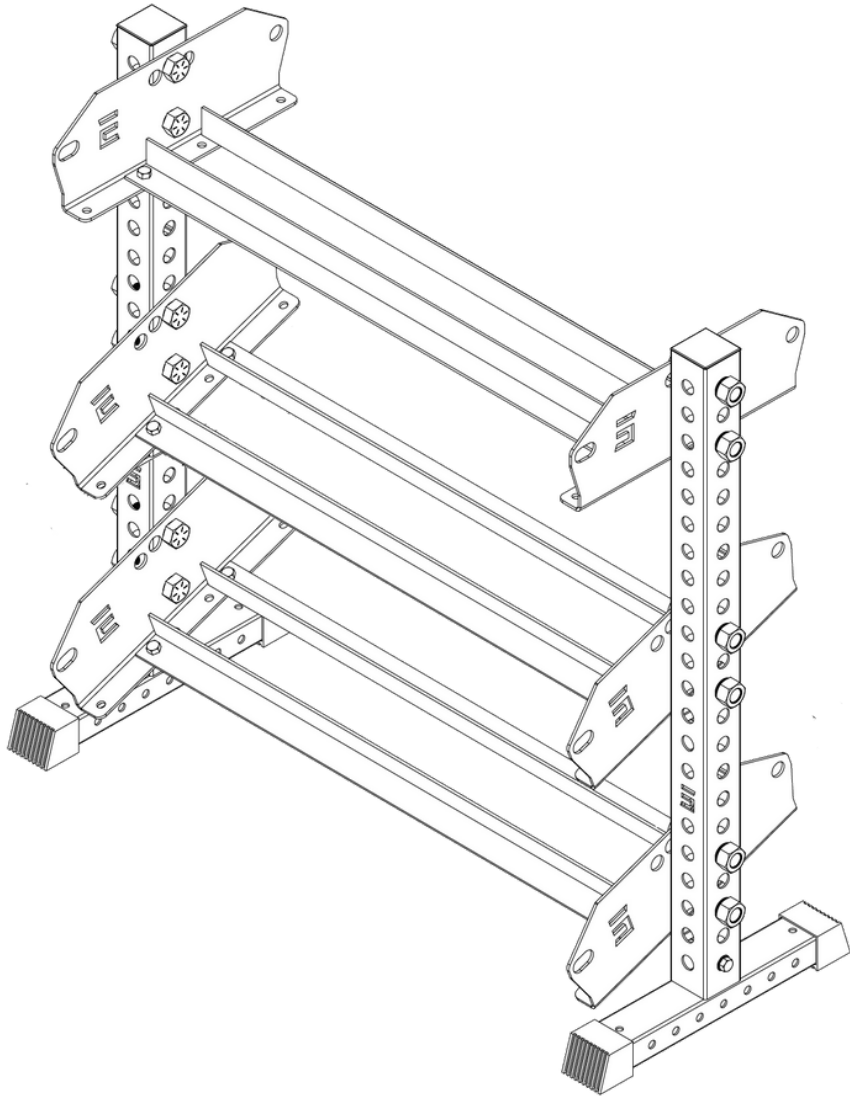

Wasn't that easy?

You have assembled your new horizontal dumbbell rack and didn't even break a sweat.

Now go brag about it in social media and get your workout done!



NEED SUPPORT?

VISIT US ONLINE!

Contact us.



We are here to support you in any way we can. Scan the QR code for options on how to best contact us or visit us at



<https://www.synergycustomfitness.com/contact-us>



You can also email us support@synergycustomfitness.com or call us at 1-877-305-4057

scan QR code to
visit us online



WARNINGS



Heavy Object.

Use lifting aids and proper lifting techniques when moving to avoid injury.



Sharp Objects.

Sharp objects may be included. Always use precaution and protection to avoid injury.



Choking Hazard.

Small parts – Please exercise caution if small children or pets are present.



Suffocation Hazard.

Plastic bags may be involved. Please exercise caution by keeping bags away from babies, small children and pets.