



H30 – Owners Manual
Polyurethane foaming equipment



















Solutions for the Spray Foam Insulation Industry

Contents

Contents	2
Warning	3
I.JHPK-H30 raw material flow chart.....	4
II Technical data of the system.....	5
III operating and requirements of air-powered FRL combination	6
3.1 Air-powered FRL combination.....	6
3.2 .The operating requirements of the air-powered FRL combination are as follows:6	
IV. System installation	7
4.1. The installation of raw material pipe system	7
4.2Air source connection and requirements:	11
4.3 Power connection and requirements:	11
4.4 JHPK-H30 Control instrument panel:(Figure 5).....	11
4.6 Emergency stop button	13
4.7 Self-lock start-up button for heater:.....	13
4.8 Temperature setting for temperature controller:	14
4.9 Master power switch:	15
4.10 Electrical cabinet:	15
4.11 Over-temperature protection:	15
4.12 About the use of counter:.....	15
4.13 About pneumatic reversal system	16
4.14About large volume and portability of the equipment heat preservation pipe set	
16	
V. System operation.....	18
5.1. Pre-operational inspection:.....	18
5.2. Initial start-up: (first installation and operation of new equipment)	18
5.3. Daily shutdown steps:	19
5.4 Daily maintenance:.....	20
5.5 Preparation for a long-time shut-down:.....	21
6.1 Inspection of abnormal display of raw material pressure gauge:.....	23
6.2. Overhaul the host failure to operation:.....	24
6.3 Maintenance of booster pump.....	24
VII. Assembling and exploded view and list of parts for booster pump	30
List of Booster Pump Parts	31
VIII. JHPK-H30 Schematic Circuit Diagram	33
VIII JHPK-H30 Control Panel Wiring Diagram	34
X. JHPK-H30 Electrical Cabinet Wiring Diagram.....	35

Warning

 WARNING		
	<p>Danger of Electric Shock It will cause electric shock if inappropriate connection with the earth, set-up or use of the system.</p> <ul style="list-style-type: none">• Disconnect the general electric power of the mainframe before maintenance.• Keep the good connection with the earth during equipment operation.• Do not explore the equipment in the rain; keep the equipment in room.	
	<p>Personal Protective Equipment Need to wear appropriate protective equipment during operation, equipment maintenance or entering into the equipment working zone to avoid serious injury including hearing eyes, breathing poisonous gas, burning skin and hearing loss. These protective equipment are including but not limiting to,</p>	
	<ul style="list-style-type: none">• Safety Glasses• Laging Gloves• Hearing Protection Device• Protective Clothing and Respirator recommended by the liquid and solvent manufacturer	
	<p>Danger of Fire and Explosion • The flammable smoke from solvent and dope in the working area easily cause fire or explosion. In order to avoid fire or explosion please follow the instruction,</p> <ul style="list-style-type: none">• Use and clean the equipment in ventilated environment.• Make sure the working area is clean and keep the solvent, waste pieces and gases etc. away from the working area.• Stop the operation immediately if see static sparkle or feel electric shock. Do not use the equipment till finding the root cause and taking action plan.• Equip with effective fire extinguishers in working area.	
	<p>Danger of High Pressure Aluminum Parts Do not use 1,1,1 three monomer (VCM), methylene chloride, other halogenated hydrocarbon solvents or containing this kind of solvents fluid in the high pressure aluminum device.</p>	
	<p>Danger of Burn The fluid on the surface of the equipment or heating in the equipment can become very hot in operation. To avoid serious burns do not touch the hot fluid or the heating parts of the equipment. Please wait for equipment/fluid cooling down completely.</p>	
	<p>Danger of Moving Parts The moving parts will crush or cut off fingers or other parts of the body.</p> <ul style="list-style-type: none">• Be away from moving parts.• Do not operate when cover is open or taken off.• Cut off power and air supply before examine or move maintaining equipment because pressuring equipment can be started accidently without warning.	
	<p>Danger of Improper Operation Improper Operation may cause serious injury or death.</p> <ul style="list-style-type: none">• Do not operate over the rated parameters please reference to the equipment manual.• Only use the original part from equipment manufacturer for repairing or replacing and do not alter the equipment.• Keep away pipe and cable away from the public areas, sharp edges, moving parts and heating surfaces.• Do not twist or over bend pipes or use pipes drag equipment.• Please follow all the safety requirements to operate equipment.	

I.JHPK-H30 raw material flow chart

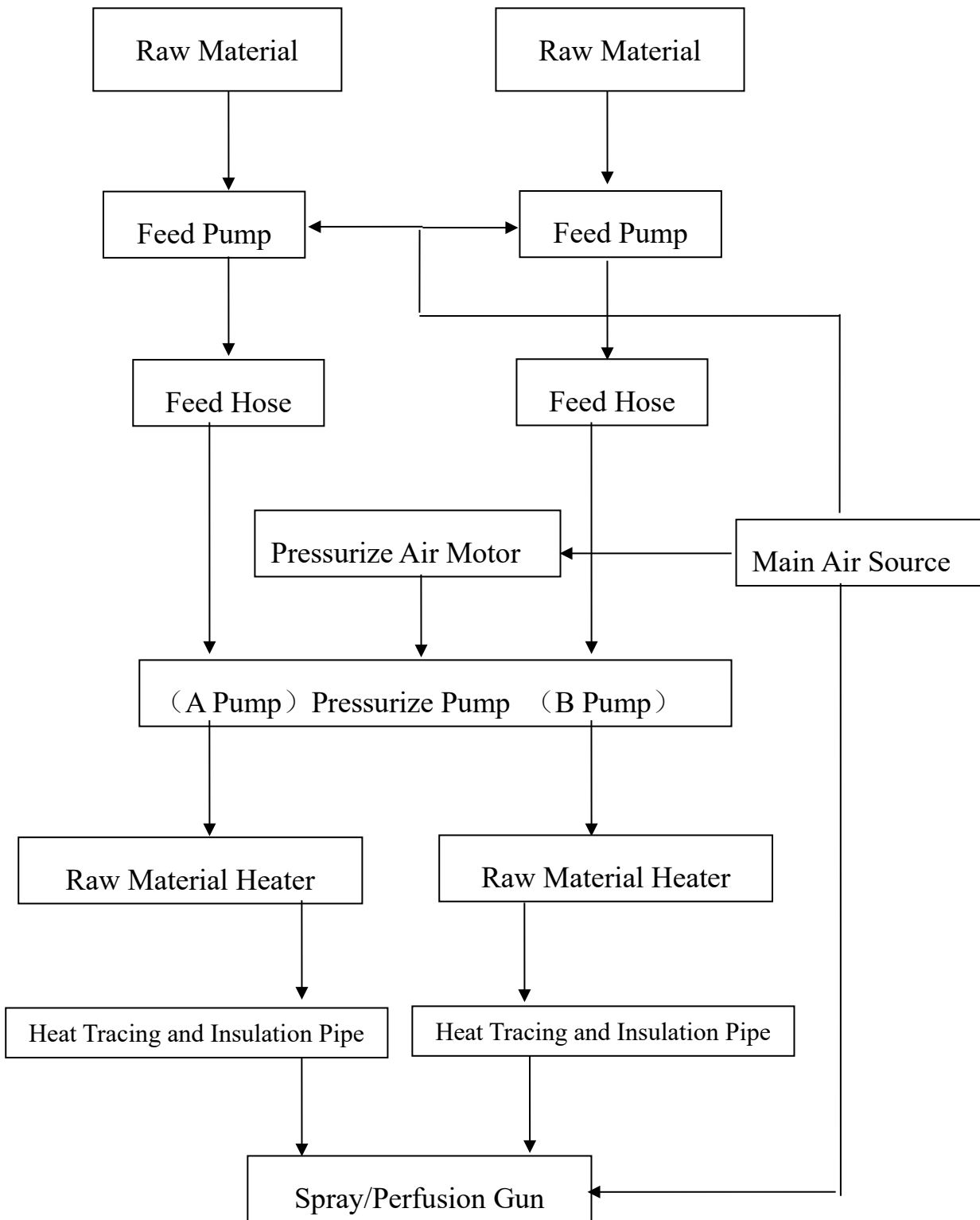

II Technical data of the system

Raw material ratio:	1:1 standard fixed ratio (changeable ratio can be selected)
Viscosity range of raw material:	200-1000CPS (under operation temperature)
Output quantity of raw material:	2-7.8kg/min
Heating temperature range:	0-70°C
Cleaning style of the gun:	Air purge
Power:	Three phase four wire 380V 50HZ 14Ax3+16A
Air pressure source:	0.5-0.8Mpa 1m ³ / min
Output pressure of single-component raw material:	5-13.8Mpa
Overall dimension:	930mmx800mmx1210mm
Weight:	125Kg
Length of heat tracing output pipe:	15m Heat tracing and insulation connecting pipe (standard ,Max .length(optional) is 90 meters)
Length of the short pipe connected with the gun:	1.5m Heat tracing and insulation short pipe

III operating and requirements of air-powered FRL combination

Note: If the air source is not clean, the seal system of air-powered components such as air pressure regulating valve, cylinder, reversing valve and so on can be damaged easily.

3.1 Air-powered FRL combination

Air-powered FRL combination is an important and indispensable component which consists of air filter, pressure reducing valve and oil atomizer (as shown in Figure 1) its roles as follows:

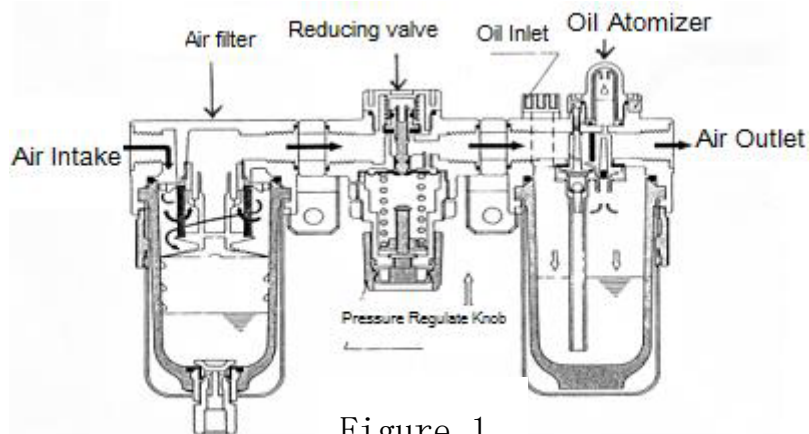

Figure 1

3.1.1 Air filter: It can filter most water brought by the air compressor in air-producing process and keep the water in the cup under the filter.

3.1.2 Reducing valve: Rotating the handle after pulling the regulator handle upward forcibly, and clockwise rotation for the pressurization, anti-clockwise rotation for the decompression; it is recommended to set the pressure at 0.5—0.8MPa, depending on the ambience and the path length; push the handle up to the original protective position after regulate the pressure to the necessary pressure by observe the barometer.

3.1.3 Air Atomizer: The lubricant in oil cup of the air atomizer will flow to all air-powered parts to complement the lubricant with the flow of air.

3.2 .The operating requirements of the air-powered FRL combination are as follows:

3.2.1. Water drainage should be did expelled every day if the cup at the bottom of the air filter has water, the steps are as follows: the water in the cup can be discharged by cutting off the main air source of the air compressor, evacuating air in the equipment and unscrew the knob at the bottom of the water cup of the air filter when the barometer being zero on the pressure reducing valve, tighten the knob after the water being drained thoroughly.

Warning: If there is possibility that the water may contact with the electrical parts when water drainage, it is important to use containers to catch the water to avoid personal harm.

3.2.2 The oil cup at the bottom of the oil atomizer is used to store lubricant, to add lubricant there are two methods. First, remove the oil and put it back after it was filled; second, fill lubricant through the oil hole at the top of the oil atomizer.

Note: The lubricant being added can be general 22#engine oil, but it must clean and free of impurities. 22# turbine oil is preferable, which must be clean.

IV. System installation

4.1. The installation of raw material pipe system

Lead Isocyanate (black) and polyhydric alcohol (white, POLY) to the pump body inlet of the host from material barrels by the feed pump, and connect the raw materials and air pipes to the polyurethane spray gun as following steps.

Note: Do not connect the equipment with power before the installation of raw materials pipe system.

If there are some users still use the F11 foaming, please pay attention to the problems below:

Under the condition of normal pressure, the F11 foaming agent in combined polyhydric alcohol will have a strong expansion when the material temperature over 23°C. At this time, the raw material barrelhead was opened quickly may lead to raw materials squirting out from the barrel. So it is suggested that act cautiously when open the raw materials barrelhead and prepare cloth, mats and other protective articles to prevent personal injury caused by the raw materials squirting out when opening the material barrelhead. To prevent personal injury caused by raw materials blown out from the barrel cap. There is degassing sound when open half of the raw materials barrelhead, and the barrelhead should be open up after air being fully discharged.

(1) Installation of the feed system:

Step 1, open the big cover of the charging bracket and insert the feed pump into the bottom of the barrel slowly, meanwhile, the tilt angle of the feed pump shall not greater than 30 degrees.

See Figure 2

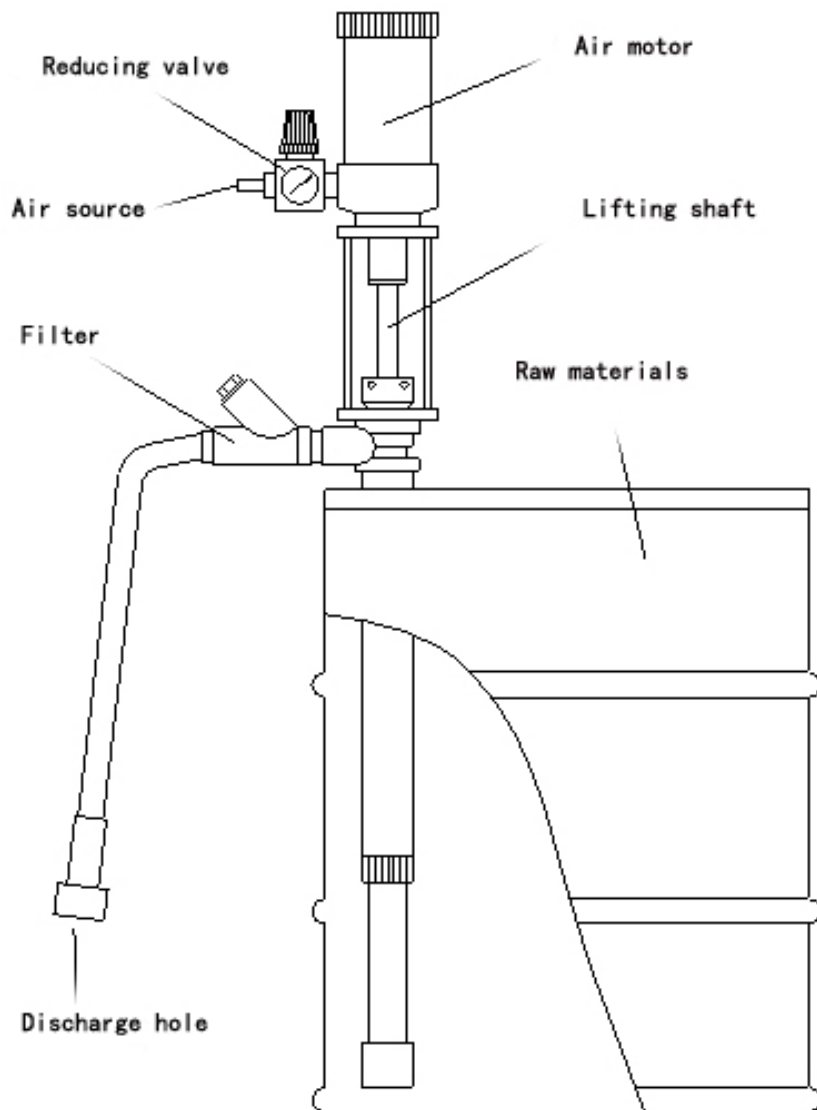

Figure 2

Step 2 , connect the feed pump conveying hose to the discharge hole filtered by the feed pump and the inlet of pump body of the host respectively. See Figure 3.

(2) Installation of the discharging system:

Firstly, remove the plastic insulation sleeve that outside of the temperature sensor wholly, feed the temperature sensor (armored extra-long thermocouple) at the exit of the main machine exit slowly into the black material pipe through the black material joint of the heat preservation hose group (the hose end is protruding). Attention shall be needed to avoid hard bending of the sensor sleeve and care shall be paid to protect the sensor on the tip. Then, the feed material is delivered out of the heat preservation hose set in sequence and is sent to the sprinkler gun via the main machine. This step is very easy. The hose run shall be clearly identified to avoid incorrect connection. When the connection from the main machine to the polyurethane sprinkler gun feed hose set is completed, it should look like Figure. 3.

(3) If it is necessary to lengthen the hose because of the construction condition, then the hose shall be connected according to Figure(4) and the output voltage of the transformer for hose heating needs to be adjusted to increase the heating power and satisfy the power requirement. The output voltage shall be compatible with the pipe run length. For adjustment, observe “connect point for pipe extension” label on the equipment and choose the voltage and connection location from Table 1 below.

Note: The factory standard configuration of this equipment is the 15m heat tracing pipe and insulation pipe, the output voltage of the transformer for the insulation pipe is 12V.

Table1

Connecting Position	A	B	C	D	E	F
Voltage of the transformer tap lead	12V	24V	36V	48V	60V	72V
Pipe length	15m	30m	45m	60m	75m	90m

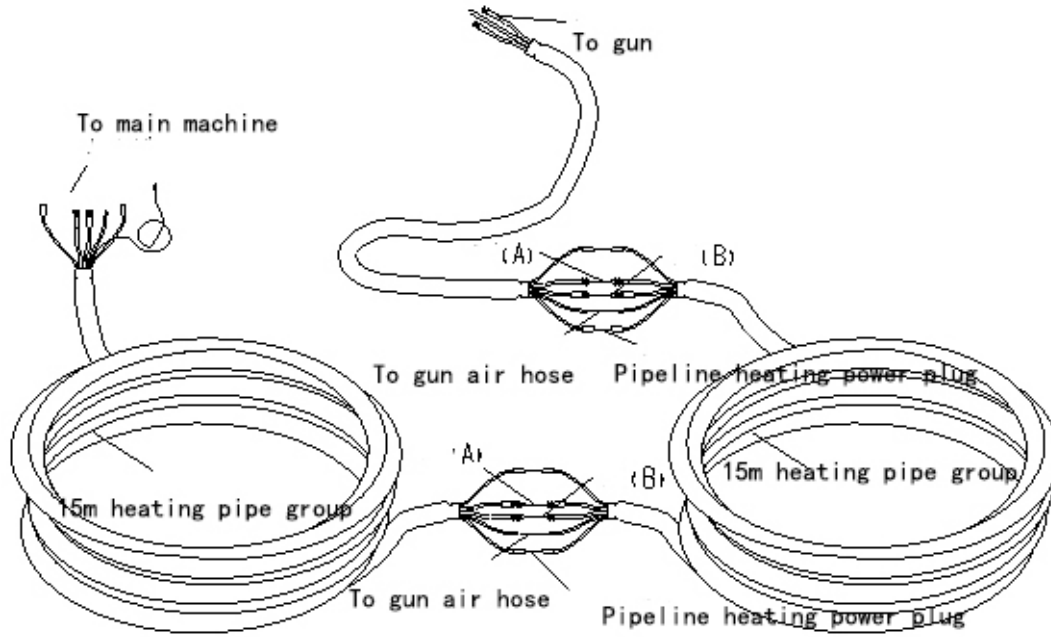

Figure 4

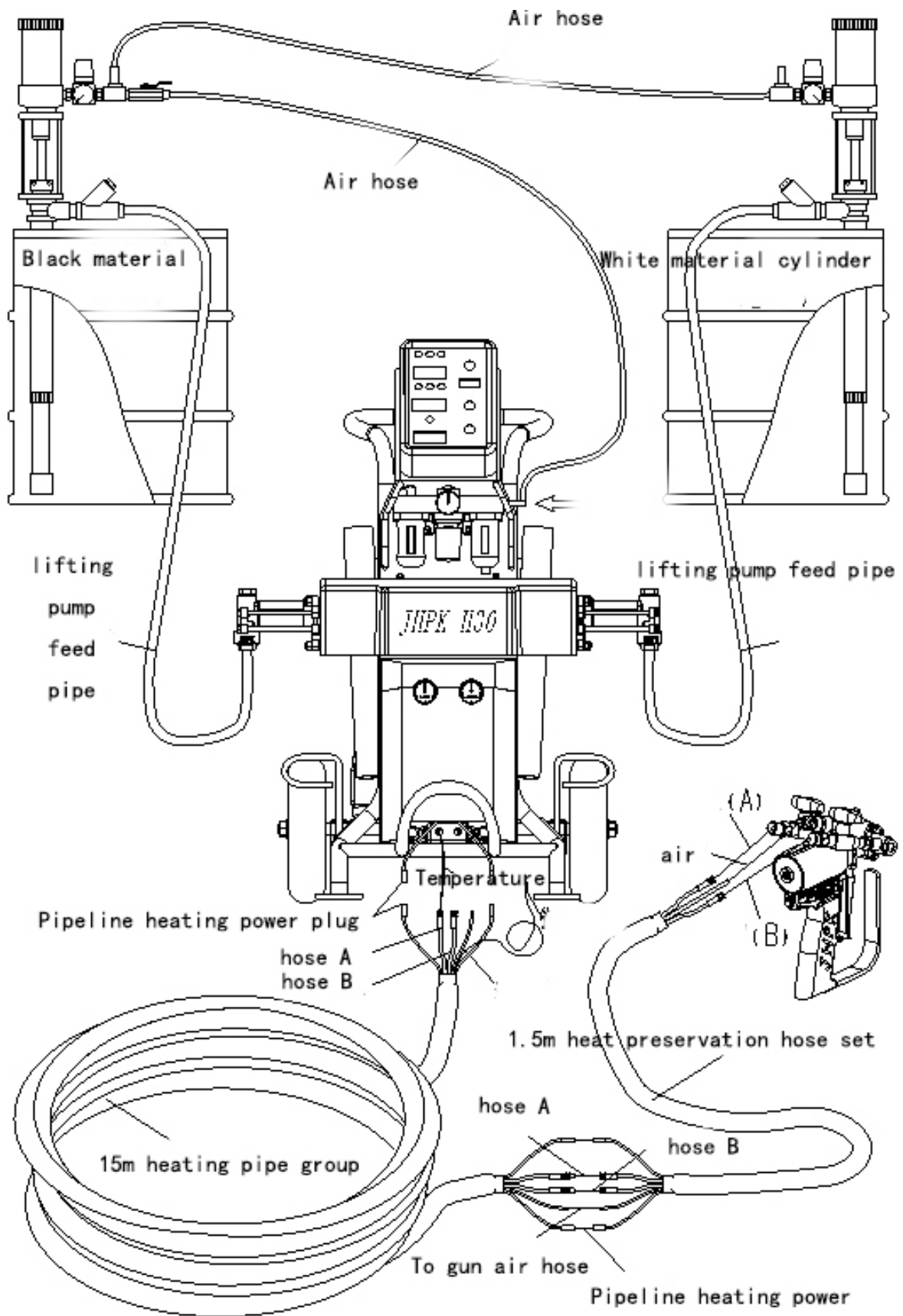

Figure 3

4.2 Air source connection and requirements:

Connect clean compressed air source of 0.5~0.8Mpa and 1m³/min to the main machine FRL inlet. The diameter of the windpipe shall be greater than 12mm.If the length of the windpipe is greater than 10mm, the diameter of the windpipe should be appropriately increased to about 20 mm that ensure the air pressure and flow rate.

Note: If the air source is not clean, the pneumatic sealing system parts like reducing valve, cylinder, and reversal valve could be damaged. So, you are advised to install an air filter and an oil atomizer between the equipment air source inlet and outlet in order to ensure the life of pneumatic components and the smoothness of motion.

4.3 Power connection and requirements:

Connect the 5 cord power that from main machine ends directly to the 380V, 50HZ three-phase four-wire power with each phase power of 7KW.The color crossing line is the protective earth line, it must connect to the ground for protecting in order to avoid unnecessary personal injury and death. Avoid unnecessary personal injury and death. The flexible wire is the ground protection cable, must be earthed.

4.4JHPK-H30 Control instrument panel:(Figure 5)

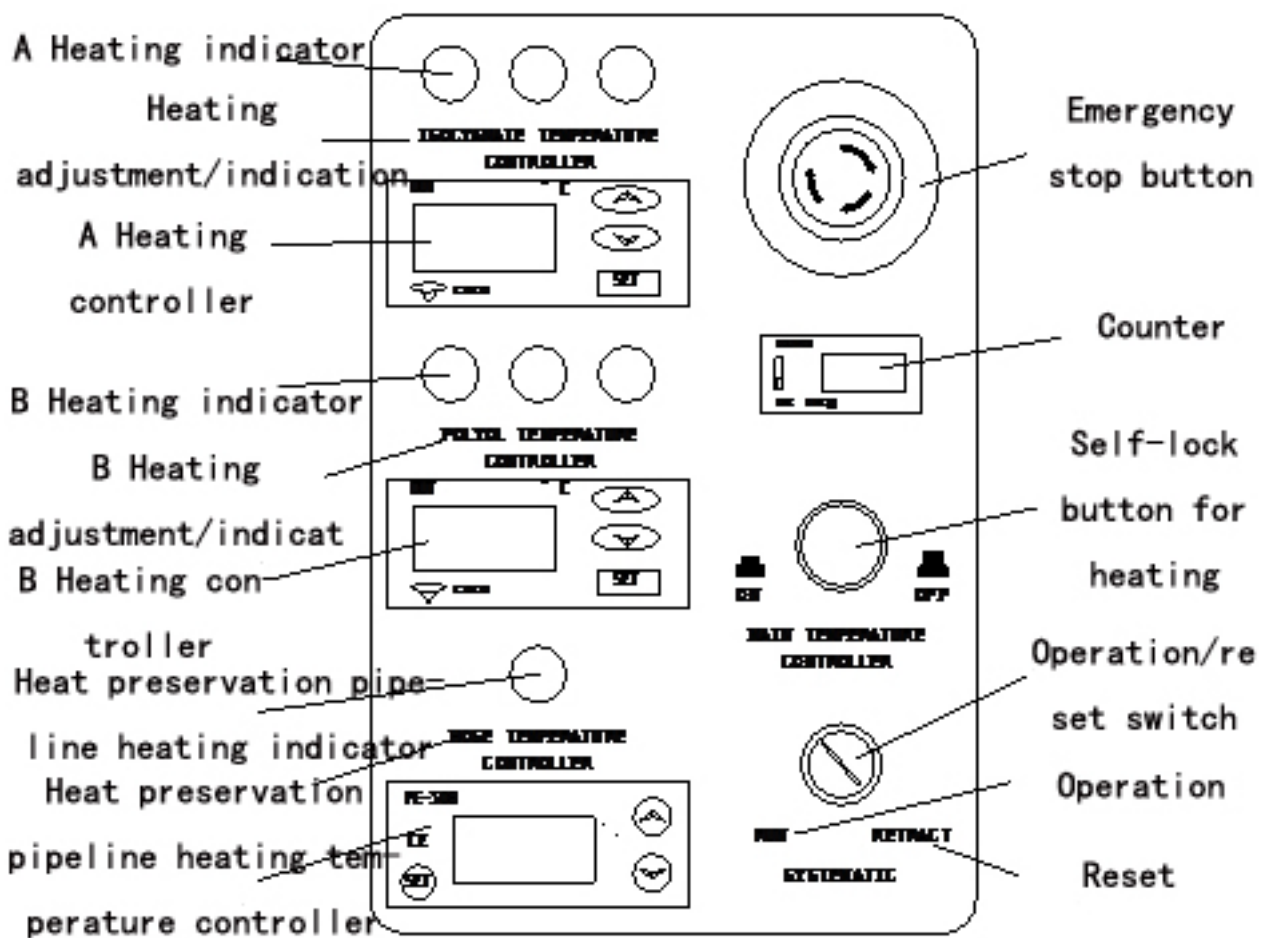

Figure 5

4.5 Run/Retract Switch

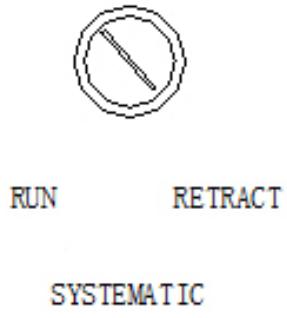

Figure 6



Figure 7

Operation steps: When the equipment is fed with air source, put the Run/Retract switch to operation position, then the booster pump begins to work normally. If short-period stop of booster pump is desirable, put the Run/Retract switch to the reset position. For long-period shut down, first turn the Run/Retract switch to the reset position, then pull the lock bolt to release material (pressure release) while keeping the booster pump working. When the booster pump shaft runs to the designed protection location, the pump will stop working. Then, release the bolt and switch off the main machine air source.

Using the Run/Retract switch, you can control the working or stopping of the booster pump. In addition, when the equipment is stopped, the reset switch makes it possible to put the piston in the anti-solidification liquid cylinder at the black material side of the booster pump to its extreme imbibition position. The lubricant fills the lubricant cylinder with the working portion of the black material shaft and of the lubricant cylinder in full contact with the lubricant, segregated from the air. This prevents the generation of black material crystals, which may scratch sealing parts.

4.6 Emergency stop button

When stopping is desired in electrical equipment emergencies, just push the emergency stop button (Figure 7). Then, all the electrical components of the equipment stop; turn the knob clockwise, the knob will reset automatically. The electrical system of the equipment resumes the work condition.

Note: Emergency stop button controls only the electrical system in the equipment. When this button is pushed, the booster pump of the main machine may still keep running. If you want to stop this pump, turn the Run/Retract switch to the reset position or switch off the main machine air source.

4.7 Self-lock start-up button for heater:

When the main power switch (Figure 8) on the electrical cabinet on the back of the main machine is closed, if it is desired to heat the black material (component A) and the white material (component B), then push the main temperature controller for heating on the control panel to a lower position to switch on the power. The control circuit of the temperature controller is powered on and the heating system works accordingly to the preset temperature. When the main temperature controller is in a high position, the power is switched off. So, if you do not want to use the heating system, just put the main temperature controller into its high position.

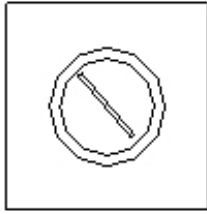

MAIN POWER

Figure(8)

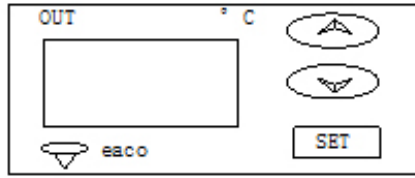

ISOCYANATE TEMPERATURE CONTROLLER

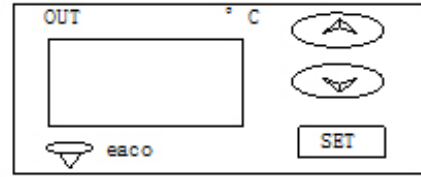

POLYOL TEMPERATURE CONTROLLER

Figure(9)

4.8 Temperature setting for temperature controller:

JHPK-H30 version equipment control instrument has three temperature controllers, used to set and control temperature for the black material (component A) heater, the white material (component B) heater, and pipeline heater.

The black and the white materials are controlled by C16H controller, the control panel of which is shown in Figure (9). The temperature controller works by variable power for heating. When the power is on, push “SET” three times, the nixie tube blinks, then push ▲ or ▼ key to adjust to the desired temperature and push “SET” once again to confirm. Then, the nixie tube blinks once, indicating a successful setting adjustment. The composition of the feeding material varies with differing formula (primarily concerning the white material). If you choose the F11 and 141b foaming, the F11 foaming have a boiling point of 23°C and the 141b foaming have a boiling point of 32°C respectively. If they are used, depending on their gasification point, the heating temperature for white materials containing F11 is usually set around 25°C, that for white materials containing 141b set around 35°C.

When it is needed to heat the insulated pipeline, adjust the voltage according to the pipe length and Table 1 data. Later, adjust the heating of the pipeline. FC-308 temperature controller is used to control pipeline heating. The operation panel is shown in Figure(10). This temperature controller works by variable power for heating. After power-on and self-testing, push ▲ or ▼ for 3 seconds to call up temperature setting display. The display shows blinking temperature setting. Push ▲ or ▼ to change the setting. Push steadily to accelerate the increase or decrease speed. When the setting is completed, push SET to save and exit. If no key is pushed, the save and exit will be done automatically after 10 seconds.

Note: When the power frequency is 50Hz, the heating voltage of the pipeline shall be adjusted as appropriate to the pipeline length and shall not exceed the value given in Table 1. Otherwise, the control module for pipeline heating will start and stop frequently, which may shorten its service life.

HOSE TEMPERATURE CONTROLLER

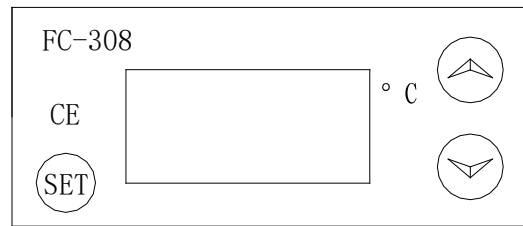

Figure (10)

Note: Both C16H and FC-308 are multi-functional temperature controllers. If unauthorized adjustment or improper operation is done, the controller may be blocked, making it unable to adjust and control.

4.9 Master power switch:

For this equipment, the power switch on the electrical cabinet is a disconnecting switch, which controls all the power switches but does not control any specific power switch in any portion. If switching-off of any particular circuit is desired, open the electrical cabinet door and switch off the air switch of that circuit.

Note: When the master power switch is off, none of the electrical components in the control panel is live. However, the input power cable and the cable between the input power cable and the master switch are live. Therefore, even if the master switch is off, the external input power must be disconnected before repairing the internal parts of the cabinet.

4.10 Electrical cabinet:

The electrical cabinet is on the back of the equipment. The master power switch is on the protruding portion of the external side of the door, convenient for switching operation. Open the cabinet, you may see a terminal block at the bottom, where you may select appropriate output voltage according to Table 1 and the pipeline length.

On the interior side of the cabinet door, there are two rows of air switches (four in total). In the top row, you may find a switch each for black material heating, white material heating, and material pipe heating from left to right. The one in the lower row is the master power switch. All these switches are in a closed position before leaving the factory. When a circuit is power off, it is possible that one air switch has tripped. You need to open the cabinet to check the problem and then close the switch.

Note: The electrical cabinet shall be operated by an electrician or a trained person.

4.11 Over-temperature protection:

The main machine heater, JHPK-H30 equipment, and the heated pipeline are equipped with over-temperature protection circuit. When the actual temperature exceeds 55°C, the heating power will be switched off automatically. During operation, if the feed material heater or the heat preservation pipeline is not working, it might be that the overload protection circuit has the power switched off. In such a case, you need to check the actual temperature of the feed material and see if the setting or the temperature is excessive. If yes, the heating system will resume working automatically after the temperature drops.

4.12 About the use of counter:

Our polyurethane foaming machine used a counter to compute the flow. By a to-and-fro movement, the booster pump displaces 64.3×2=128.6ml of bi-components and the counter counts one. By computing the accumulated count number of the counter, you will know how much feed material has been displaced during a certain period.

Setting of counter: There is a slide switch beside the displayed number. Move it to top and push down for zero clearing; for use, move it to bottom, where it will be locked. See Figure (11).

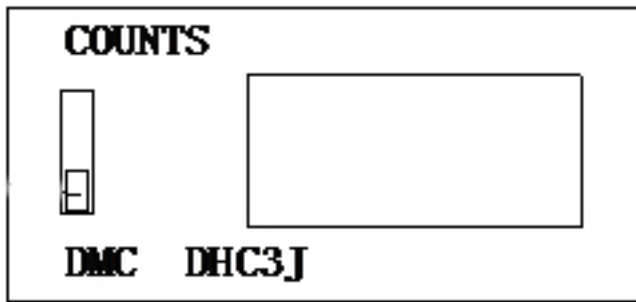

Figure (11)

4.13 About pneumatic reversal system

The reversing mechanism of the booster pump consists of a set of mechanical valves and main valves. The changeover of pneumatic path is realized by the contact and separation between particular components of the pump and the mechanical valves. The relative position among various components of the reversing mechanism is secured by the machining precision and no adjustment is needed once the assembling is completed. The pneumatic path interfaces and the connection pneumatic pipes are identified by colors. During assembling and maintenance, use pipes of matching color to join the pneumatic path. This mechanism is flexible and reliable in movement, has a low defect rate, and is easy to install and service.

4.14 About large volume and portability of the equipment heat preservation pipe set

Figure (12) shows the winding up of heat preservation hose set by JHPK-H30 main machine. On the left part, the protruding part of the horizontal booster pump and the protruding tube of the main machine stand form a spatial support, on which the heat preservation hose set may be wound. On the right part, the protruding tube of the stand, the front curved guard ring, and the guard on the right and left wheels together form a spatial support, on which the heat preservation hose set may be wound. With either method, this equipment is able to receive four sets and up to 15m standard heat preservation hose.

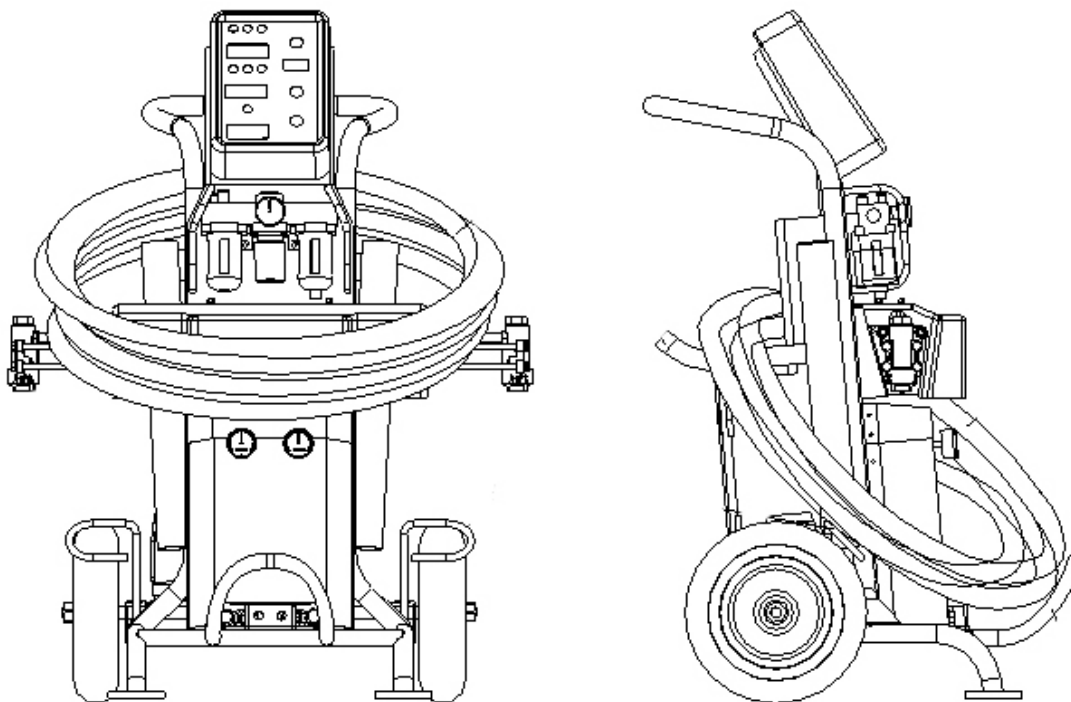

Figure (12)

The general layout of the equipment has given due consideration to spatial usage. Even if more sets of heat preservation hose are received, the designed space for movement and maneuverability can be guaranteed and one operator is able to move the equipment alone. The large volume and the portability of the heat preservation hose sets increase the suitability of the equipment, provide great convenience to the operator, and save labor force while improve the efficiency.

V. System operation

5.1. Pre-operational inspection:

5.1.1 If the anti-solidification lubricant reservoir contains DOP (dioctyl o-phthalate) of no less than 4/5 of the reservoir volume.

5.1.2 .Check that all joints are securely tight

5.1.3. Check that power line is connected correctly. And the protective grounding wire is connected safely and reliably.

5.1.4. Check that all switches are in OFF position.

5.1.5. Check whether the air source regulator was switched to OFF position.

It is prohibited that placing any part of the body in the path of the material spray, pointing the gun at or near other persons and looking at the mixing chamber orifice at any time. Because of the hazardous materials used in the equipment, it is recommended that the operator use an air mask, goggles, protective clothing and other safety equipments. Before operating, the operator must read the caution text on the previous page of this manual.

5.2. Initial start-up: (first installation and operation of new equipment)

After satisfactory confirmation of the connection of all the stream tubes, air hoses, and power cables, the system may be operated. The operator must fully understand each function of the control instrument and have necessary precautions ready.

The steps are as follows:

Step 1: Switch on the main power knob and adjust the pressure regulator knob of the main air valve to gain a pressure of 0.2Mpa.

Step 2: Push the run/retract knob to the operation position. Then, the main machine starts up and the material pipe system is filled with feed material and the heat preservation hose is heated. The equipment stops once the material is filled full.

Step 3: Remove the two conveying material pieces on both sides of the tip chamber.

Step 4: Place a clean container under the two conveying material pieces respectively, at the same time open material valve of the two pieces slowly for emptying all air in the conveying pipe until the raw materials spraying out smoothly. See figure13

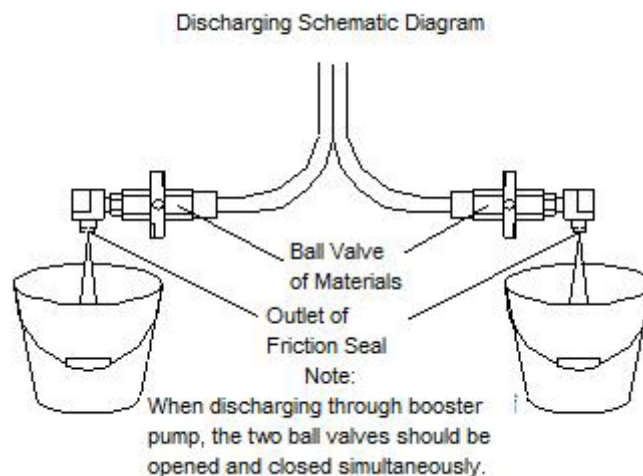

Figure (13)

Step 5: close the two material valve at the same time, however, the pressure showed in the pressure gauge of raw materials should be equal to each other, if not, open the material valve in higher pressure side slightly so that the raw materials will flow out until the two pipes approximately at the same pressure.

Step 6: deal with the waste reasonably and securely.

Step 7: clean up the residual materials on the conveying material pieces and coat with grease, after that re-assemble the conveying pieces in the gun. Fastening the bolt of the conveying pieces evenly, so that the two friction on both sides of the gun being in close contact with the tip and to sure there is no air and material leakage and the tip acts flexibly.

Step 8: straighten the conveying pipe group to avoid uneven heating and damage the internal heating wire, Push the self-lock button for heating to its lower position to power on the heating system.

Step 9: Set the heating temperature for the black and the white material heaters and the heat preservation hose line according to the description of 4.8 for temperature controller setting. Increase the air source pressure of the main machine to the working value only after the temperature reaches the preset value.

Note: Due to expansion of the combined polyhydric alcohol when heated, the main air source pressure of the JHPK-H30 spray system can't be set at working pressure before operating to avoid damage of the pressure gauge even pipe burst caused by the heating of the raw materials in the pipeline.

Step 10 , regulate the air source pressure to 0.5-0.7Mpa by adjusting the air source pressure valve of the host. (Reference value)

Step 11, firstly open the air inlet switch on the gun body and then open the material valve on the two conveying material pieces.

Step 12, at the moment, the entire system has been ready for running as just pulling the trigger can spray materials.

Note: The material valve should be shut off when you stop operation, so that prevent the emission of raw materials caused by mal-operation.

5.3. Daily shutdown steps:

Note: Be sure that the reset/work change-over switch have been switched to reset position when each shutdown, Pull the lock bolt to release material (pressure release) while keeping the booster pump working. When the booster pump shaft runs to the designed protection location, the pump will stop working. Then, release the bolt and switch off the main machine air source. At the same inspect the sprinkler gun to prevent the gun from unable to operate again because of the damage of seals inside the gun occurred in using which may causing materials leakage and solidify in the gun.

Shutdown steps:

Step1, Push the main temperature controller knob and make it on a high status. Then the heating system will stop heating.

Step 2, check the sprinkler gun. Take the next step after be sure that the sprinkler gun is trouble-free and can operate properly next time. Otherwise, maintenance and repair for the spray gun should be carried out; for the cleaning steps, see the section of cleaning and maintenance section in "operating guide of spray gun".

Step 3, Push the run/retract switch to reset position, pull the lock bolt to release material (pressure release) while keeping the booster pump working. When the booster pump shaft runs to the designed protection location, the pump will stop working. Then, release the bolt.

Step 4 , Cut off the main power switch.

Step 5, lose the air source, meanwhile the number showed in the barometer should be zero;

Step6, clean up the job site and be sure that the above daily shutdown steps have been completed. Check whether there are sufficient materials for next start-up and ready for work again.

5.4 Daily maintenance:

5.4.1 Fill and replacement of lubricant

The lubricant DOP (dioctyl o-phthalate) prevents the formation of crystals of feed materials on the booster pump shaft, thus avoiding scratches or damage to sealing parts. Therefore, attention and maintenance shall be needed from time to time.

- ✓ Lubricant shall be replenished regularly and discolored lubricant shall be replaced in such a way that the lubricant shall occupy at least 4/5 of the lubricant reservoir volume.
- ✓ Gelled lubricant or lubricant with significant flocculent deposit must be replaced.
- ✓ The gradual darkening of lubricant color is caused by small amount of feed material seeping through the sealing parts during operation. It is a normal phenomenon. If the darkening occurs within a short period, stop the machine immediately, tighten the clamping cap of the booster pump, and replace the lubricant before re-start the machine.
- ✓ Clean the non-return valve periodically to ensure the smoothness of the liquid path.
- ✓ Note: The return pipe of the liquid reservoir must reach the reservoir bottom while the top pipe needs to reach the 2/3 depth; see Figure. (14).

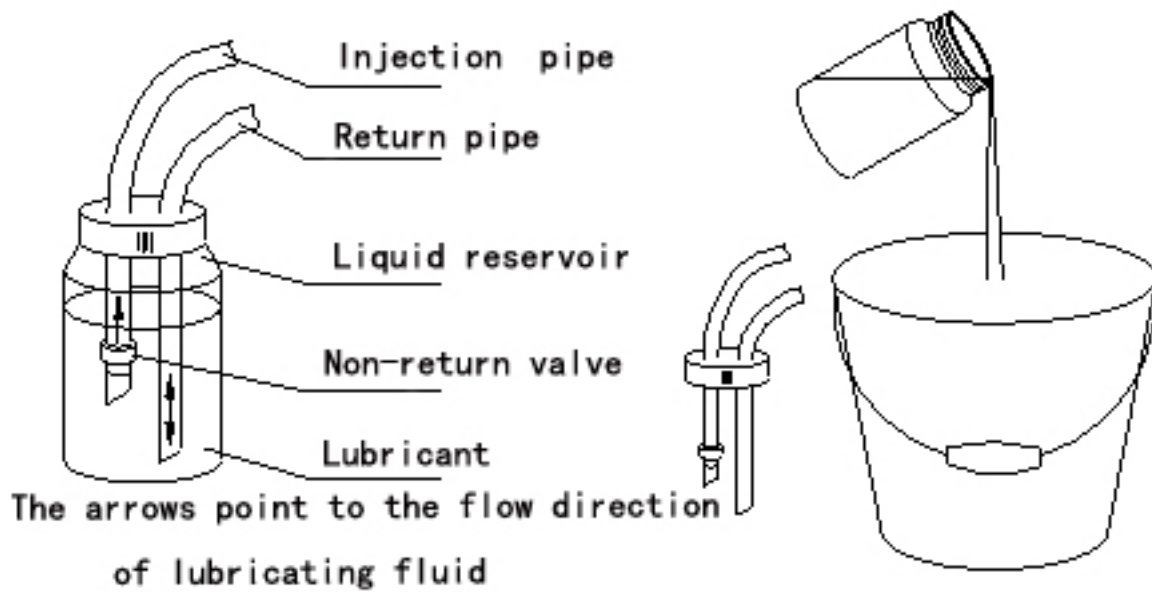

Figure(14)

- ✓ The top pipe for lubricant is connected to the upper joint of the delivery end block while the return pipe is connected to the lower joint.
- ✓ Waste liquid shall be disposed properly to avoid environment distress.

5.4.2 Apply evenly a coat of grease on the cylinder shaft on a regular basis.

5.4.3 Perform spray gun inspection and maintenance according to the routine shut-down inspection steps.

Note: Pressurized equipment may start up unexpectedly without any warning sign. Always cut off power supply, release all pneumatic and hydraulic pressure before inspecting, moving, or repairing the equipment.

5.5 Preparation for a long-time shut-down:

5.5.1 Method I:

This method is used for keeping and storing the equipment for a relatively short period. Observe the following procedure: (Always provided that the feed bucket has feed material)

Step 1: Switch on the main air source (no need to connect the main machine power supply), open the regulating valve of the feed pump to set the air pressure to 0.1—0.2Mpa.

Step 2: Adjust the pressure regulating valve knob of the main machine FRL so that the pressure is 0.2Mpa.

Step 3: Set the operation/reset switch to operation position, pull the lock bolt as if in a normal foaming operation and point the gun to a disused container so that the black material (isocyanate) and the white material (polyol) liquids flow out of the gun, Attention: check that the two different liquids actually flow out of the gun. At this time, the two material liquids need not to foam. The purpose is to make the material liquid flow in the pipeline. After confirmation, discharge the material for about 20 sec.

Step 4: Shut down the machine as if in a routine shut-down operation.

Note: If performed once every 15 days, this procedure is effective in preventing black material (isocyanate) crystallization in the hose.

5.5.2 Method II:

This method is for an excessive period of nonuse of the equipment; for example, shut-down for winter or for an indefinite period of time. observe the following procedure: (mainly for isocyanate)

Step 1: Lift the feed pump from the feed bucket and clean the pump exterior surface of feed material using solvent.

Step 2: Put the feed pump into a container filled with clean solvent. Switch on the regulating valve of the feed pump to set the air source pressure to 0.1-0.2Mpa.

Step 3: Connect the main machine air source, adjust the main machine air source pressure to 0.1-0.2Mpa.

Step 4: Open the feed valve and spray the residual material remained in the equipment system into a suitable container until clean solvent flows out. This step cleans off the feed material off the system using solvent.

Step 5: Put the feed pump into a container filled with DOP (dioctyl o-phthalate) protection liquid.

Step 6: Start the equipment to let the system recycle for 2-5 minutes and then close the ball valve; make sure the equipment material path is filled with DOP solvent and a 1-2MPa pressure is maintained.

Step 7: Shut down the equipment in a routinely manner, seal all material inlets and outlets.

VI. Inspections of flow system and equipment problems

As a qualified operator you need to know the following:

1. What is the normal material?
2. How to operate the equipment?
3. What is the normal operation situation of the equipment?
4. What is the flow direction of the raw materials in the equipment?

6.1 Inspection of abnormal display of raw material pressure gauge:

Maintenance must be conducted sequentially and started from the first step. And it should be determined by the number showed in the raw materials pressure gauge. Due to the different raw materials, temperature and viscosity, so the equivalent value in the pressure gauge of the feed pump and host is not necessary, the pressure value of the air source can be adjusted according to the operating speed of the feed pump.

Step 1, to determine what kind of raw materials are missing or disappeared.

First of all, observe the color of raw materials and foam out of the gun, and stop operation and check the gun when found any problems. When one of pipeline lack of raw materials which can contribute to low pressure of raw materials showed by the pressure gauge, this phenomenon indicates that there are sufficient materials supplying among each feeding systems, so it is necessary to check whether there is obstruction or lack of raw materials in the barrels.

Step 2, for lack of materials in one of pipelines caused by sufficient materials supplying, inspection and repair work should be started from the farthest end of the host and from the most basic and easily noticeable aspects.

Step 3, To the low number showed in the pressure gauge of raw materials, the following aspects should be checked:

1. Whether there are raw materials in the barrels?
2. What is the temperature of raw materials?
 - a. A high temperature may result in premature expansion of foaming agent F-11 inside the polyol bucket. (if F11 foaming agent is used)
 - b. Too low temperature at the bottom of the barrels of raw materials will lead to increased viscosity resulting in feed pump blocked or impeded flow of raw materials which can block raw materials entering into the system.
3. For feed pump, see "operating guide of feed pump"
 - (A) Whether or not in running?
 - (B) Whether the air source valve being switched on?
 - (C) Whether the pressure of air source has been adjusted to an appropriate value?
 - (D) Whether there is dirt in the shaft of the ISO lifting pump of isocyanate? (If there is dirt, it indicated that the shaft has not been lubricating protection in advance, or there is no lock of lubricating fluid cup J10038-81, resulting in materials spilling).

- (E) Check the filter of the feed pump.
- (F) It is best to determine the problems of main body of the feed pump after all other parts have been determined don't have any problem, and pay particular attention to item (B) of subsection (2) to B in step 3.

4. Filter

- a. Check whether the filter in the outlet of the feed pump was installed or blocked.
5. Booster pump: Determine the side in which the fault exists (in the black or the white material side); whether the defect occurs during the suction and discharge strokes of the booster pump at the side concerned or only during the discharge stroke. See Figure (15).
- (A) If pressure loss occurs during the suction and discharge strokes, then check the ball backflow seat valve body of the booster pump inlet block for its tightness and the lifting cup on the pump shaft.
 - (B) If pressure loss occurs during discharge stroke only, then check the ball cup at the inlet end block of the booster pump for tightness.

Step 4, If there is too high number showed in the pressure gauge of raw materials, the following aspects should be checked:

(1) Check whether there is obstruction in the filter of the gun's conveying piece of black materials.

(2) Whether there is solidify of raw materials in the pipe from the pressure gauge to the spray gun, resulting in impeded flow of raw materials.

(3) Check whether there is obstruction and impeded flow in all parts of spray gun, resulting in too high number showed in the pressure gauge.

The problems found out in the inspection conducted according to the above steps should be resolved as soon as possible against "operating guide of the spray gun". If the device was exposed to air for a long time will lead to other problems; such as the moisture into the system will lead to solidify of isocyanate(ISO).

6.2. Overhaul the host failure to operation:

The reversal system of the main machine works pneumatically, with the reversal air path composed of 4A420-15 2-state and 5-way reversal valve, two S3R-05 mechanical valves, and reset switch. When the main machine is connected to the air source, put the operation/reset knob to the operation position, and the main machine cylinder piston shaft will move left-to-right, in response to the pressure in the liquid system. If the main machine does not motion, check the following:

- (1) The air source pressure is not sufficient or not present;
- (2) The operation/reset knob is in "reset" position;
- (3) Check air branches for blocking or damage;
- (4) Check fluid path for material discharging smoothness;

6.3 Maintenance of booster pump

Horizontal pneumatic booster pump has a general construction as shown in Fig. 15. The black and the white material booster pumps are positioned on the side of the cylinder symmetrically, connected together by the shafting coupler. In this system, the cylinder is driven by compressed air while reversing mechanism of the pneumatic body is responsible for the to-and-pro movement of the shafting.

An anti-solidification lubricating assembly is installed between the black material pump and the cylinder. The anti-solidification seal gland is filled with lubricant DOP; whereas the black material booster pump shaft is

always submerged in the lubricant, completely isolated from the air. This prevents the feed material from crystallizing on the pump shaft and avoids damage or destruction of the sealing parts caused by crystals.

The in-series layout of the functional parts of booster pump, the proper structure of shafting couplers, and the utilization of anti-solidification lubricant assembly at the black material end improve effectively the working condition of seal parts, reduce their wearing and replacement frequency, and reduce significantly the feed material pressure fluctuation when the booster pump reverses the direction. This helps minimize the overall weight of the equipment and make the equipment cleaner and more friendly to the environment.

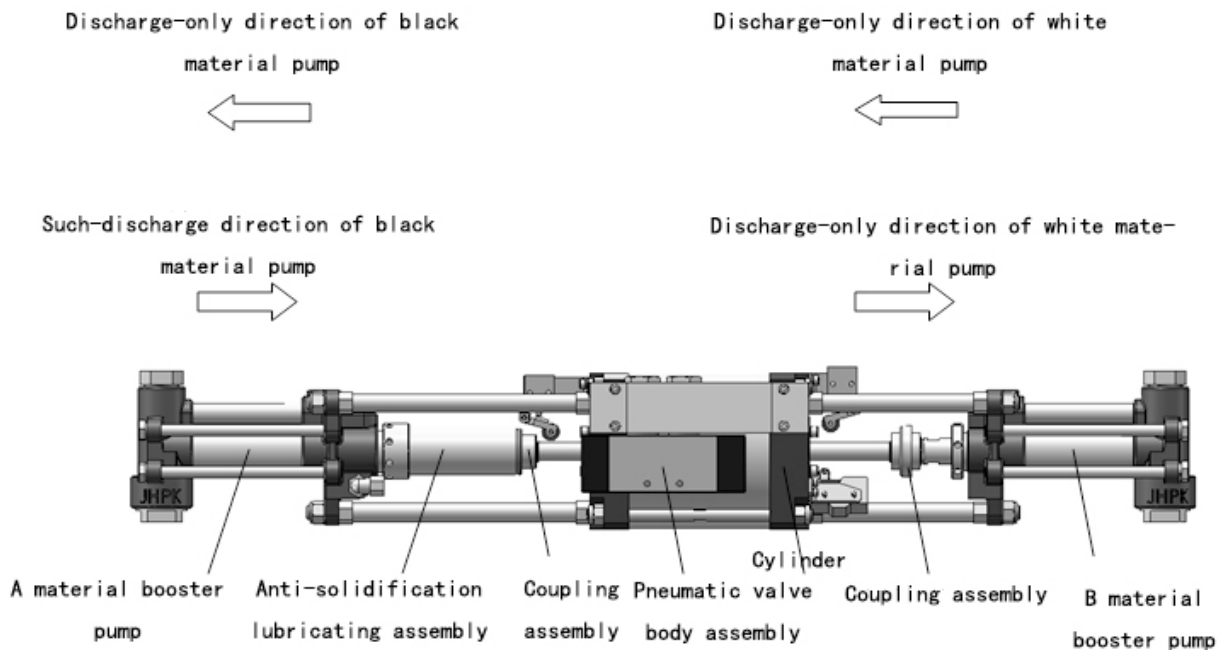

Figure. (15)

6.3.1 Disassembling the black and the white material booster pumps

The power between the black and the white booster pumps and the cylinder shaft is transmitted by coupler assembly, which has a construction as shown in Figure (16).

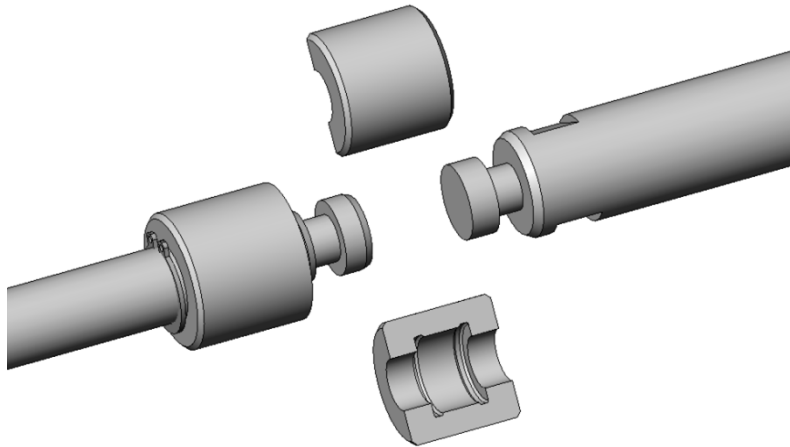

Figure (16)

Two half-cylinders with internal recess may engage tightly with the shaft end boss. The positioning sleeve of the coupling encompasses the coupling, connects and restrains the two coupling parts. Additionally, a shaft retainer ring is used for positioning. For disassembling, remove the retainer ring from its holding groove, move the positioning sleeve, and separate the two coupling parts; then, the end of the two shafts may be disengaged. This construction transmits axial movement reliably and solves the fitting problem of axiality precision of each shaft for shaft transmission.

Figure (17) exhibits the exploded view of the black material booster pump. During disassembling, the booster pump is in a reset mode, namely the shafting coupler reveals the anti-solidification liquid cylinder. Remove the coupler to separate the shaft ends, loosen the lock nuts (three), then the black material booster pump may be removed along with the anti-solidification lubricant portion. The white material booster pump may be handled similarly. With this construction, you can quickly remove the feed material pump portion for inspection, facilitating equipment maintenance and use; when necessary, the feed material pump may be replaced by a pump of different function to expand the mix formula possibility.

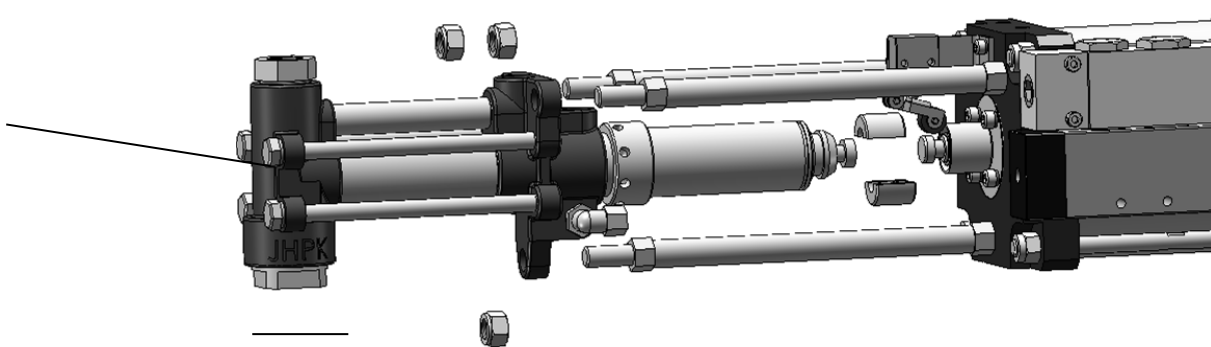

Figure (17)

6.3.2 Tightening the seal clamping cap

A seal clamping cap is installed on the delivery end block of both the black and the white material booster pumps. It is provided to fix and secure the seal cup (part No. JAPS-305Y) installed on the delivery end block. The clamping cap force is adjustable. A suitable clamping force provides ideal sealing effect and does not generate excessive resistance to the booster pump shaft.

Given the properties of the raw materials, an anti-solidification lubricant component is installed between the black material booster pump and the cylinder. This anti-solidification lubricant cylinder is filled with DOP and is intercommunicated with the liquid reservoir. The gradual darkening of lubricant color is caused by a small amount of feed material seeping through the sealing parts during operation. It is a normal phenomenon. However, if the darkening occurs within a short period, stop the machine immediately, and adjust the seal clamping cap force.

At the white material booster pump side, the operator may check the leakage directly because of the absence of anti-solidification liquid cylinder and then decides whether to adjust the clamping cap force.

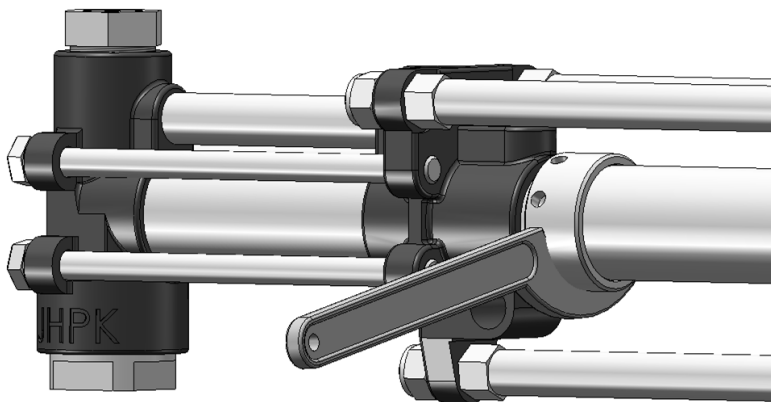

Figure 18

For adjustment, use a special spanner to tighten the booster pump clamping cap adequately; mind that each tightening operation should ideally not exceed about 1/3 circle. Figure (18) shows the adjustment for the black material seal clamping cap. The adjustment for the white material seal clamping cap is similar only that the tightening direction is reversed.

If severe leakage exists after repeated tightening, the sealing cup (part No. JAPS-305Y) inside the clamping cap should have been worn excessively and the compression compensation might not be enough. The problem can be resolved by replacing the sealing cup.

Note: For adjusting the seal clamping cap, the protection casing of the booster pump shall be removed firstly. Before adjusting, all pneumatic and hydraulic pressure must be released; otherwise, the resistance would be too great to allow for seal clamping cap tightening operation and, besides, pressurized equipment may start unexpectedly without any warning, resulting in personal injury.

6.3.3 Replacing wearable parts of booster pumps for black and white materials

The booster pump for black and white materials has a construction as shown in Fig. (19), on which wearable parts are identified. The service personnel may locate the defects and replace parts as described in the troubleshooting paragraphs. During routine maintenance, the service personnel may dismantle the booster pumps periodically for maintenance and replacing worn sealing parts. Table 2 is a list of wearable parts. The restoring spring in the table is installed at the big and small balls and is not shown in the figure. The springs help restore the balls.

Table 2

Part No.	Part designation	Part No.	Part designation
H30-01-02	Sealing gasket of the bottom ball cup	H30-01-03	Material inlet at the pump bottom
H30-01-38	Big ball valve plate	JY21218-00	Small ball seal compression ring
JY20204-00	Small ball backflow seat	JAPS-305Y-01	Retaining ring of booster pump
JAPS-305Y	Sealing cup assembly	JAPS-305Y-02	Booster pump compression ring
JY13867-43	O-ring (material cylinder)	JY21105-01	O-ring (material conveying pipe)
J7554-12	O-ring (lifting cap holder)	JAPS-128	Big ball
JY21208-01	Small ball valve plate	JAPS-133	Small ball
JAPS-305Y2	Booster pump lifting cup	JY21207-01	O-ring (small ball backflow seat)
JFS-110	Booster pump lifting cup support	J16943-00	Restoring spring of hydraulic lock bolt

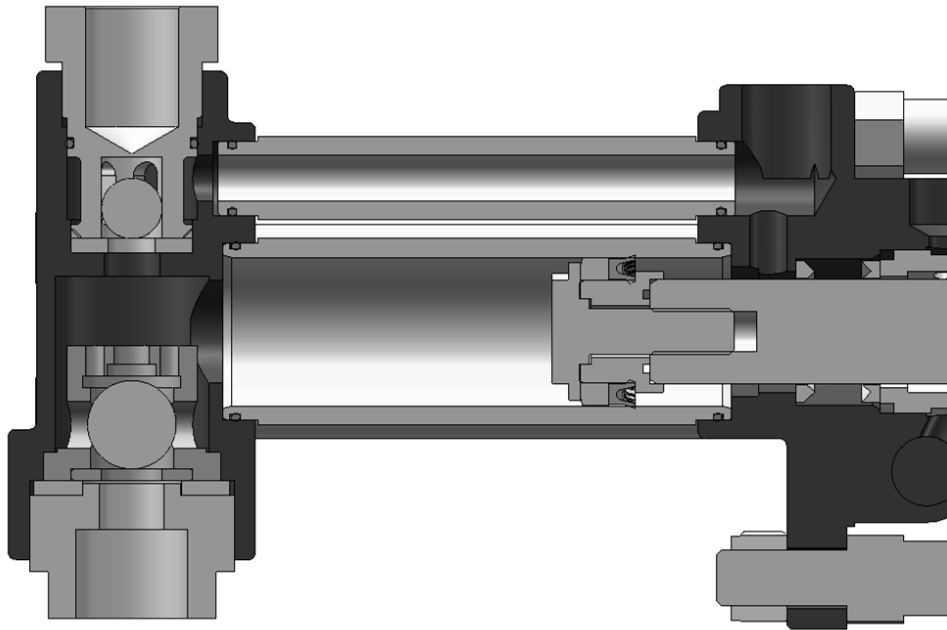

Figure. (19)

6.3.4 Seal parts of anti-solidification lubrication portion and pneumatic portion

Anti-solidification lubrication portion contains only two types of sealing parts: Y-ring (part No. H30-01-42) and anti-solidification liquid cylinder O-ring (JY13867-43). Under normal operation, the two sealing parts are not wearable. Just be careful when removing and installing them during maintenance.

Pneumatic parts of booster pumps include cylinder, pneumatic valve, air guideboard, and reversal valve coupler, etc. They have a small failure rate and a long life; in routine maintenance, they do not need to be disassembled. In case of faults, firstly check the air path for smoothness, and check the valve bodies for proper operation, as valve bodies are not repairable and shall be replaced in their entirety. If it is desirable to disassemble the cylinder or other pneumatic parts, use the replacement parts listed in Table 3.

Table 3

Part No.	Part designation	Part No.	Part designation
H30-01-39	O-ring (cylinder barrel)	H30-01-40	O-ring (piston)
H30-01-41	Pneumatic dust-proof rod seal	JY21207-01	O-ring (guide sleeve)
TLB-01-51	O-ring (cylinder shaft)	JY21105-01	O-ring (air guideboard)
H30-01-34	Reversal valve seal gasket	TLB-01-51	O-ring (reversal valve connection piece)

VII. Assembling and exploded view and list of parts for booster pump

For easiest parts selection, visit EquipmentOptionsDirect.com to view our interactive parts selectors.

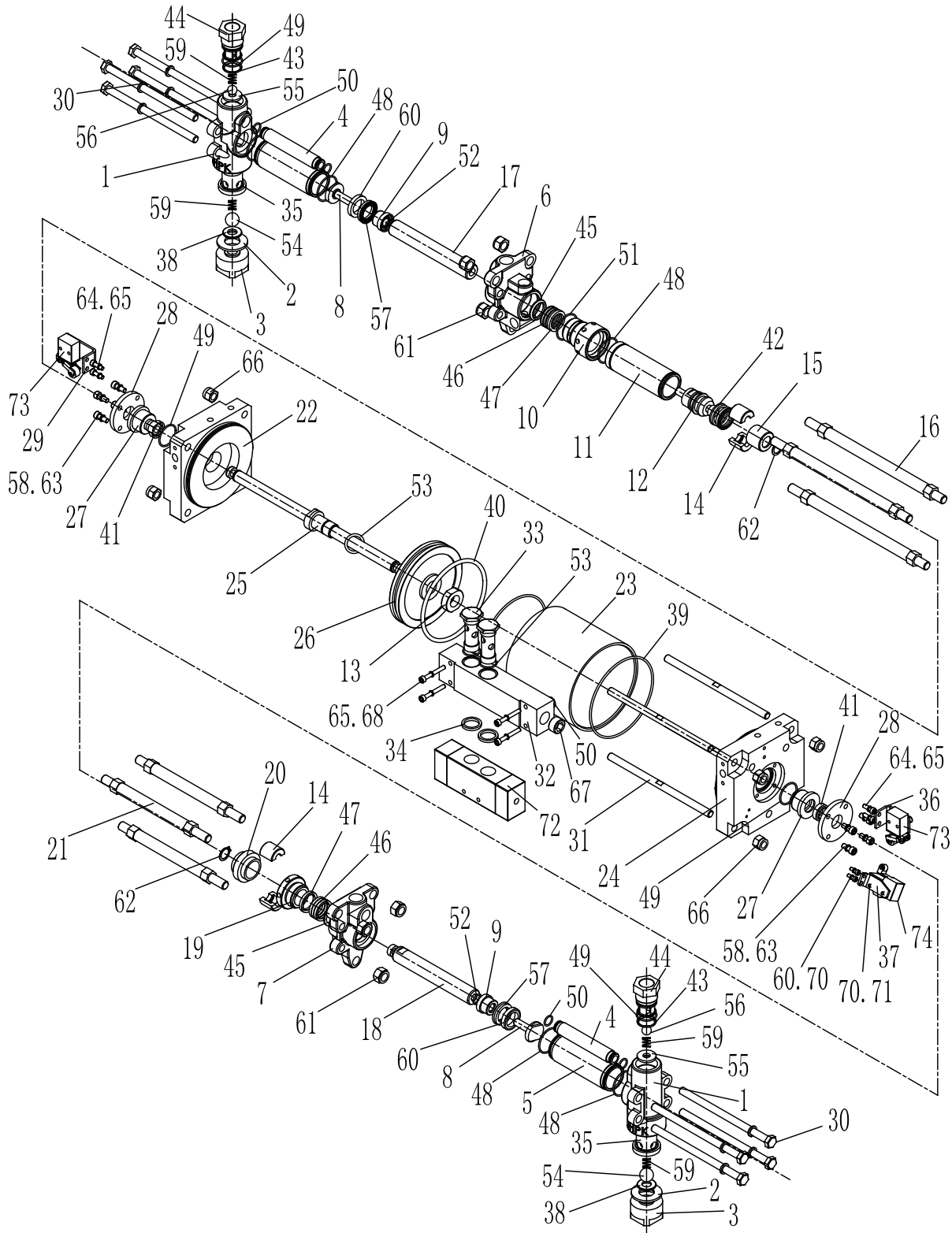

List of Booster Pump Parts

S/N	Part No.	Part designation	S/N	Part No.	Part designation
	H30-01-01	Inlet end block	38	H30-01-38	Big ball valve plate
2	H30-01-02	Sealing gasket of the bottom ball cup	39	H30-01-39	O-ring, Φ 118x2.65
3	H30-01-03	Material inlet at the pump bottom	40	H30-01-40	O-ring, Φ 115x5.3
4	H30-01-04	Material conveying pipe	41	H30-01-41	Pneumatic dust-proof rod seal
5	H30-01-05	Material cylinder barrel	42	H30-01-42	Y-ring
6	H30-01-06	Black material delivery end block	43	JY21218-00	Small ball seat seal compression ring
7	H30-01-07	White material delivery end block	44	JY20204-00	Small ball backflow seat
8	H30-01-08	Lifting cup hold-down bolt	45	JAPS-305Y-01	Retaining ring of booster pump
9	H30-01-09	Lifting cup holder	46	JAPS-305Y	Sealing cup assembly
10	H30-01-10	Black material seal holder	47	JAPS-305Y-02	Booster pump compression ring
11	H30-01-11	Anti-solidification liquid cylinder	48	JY13867-43	O-ring, Φ 31.5x1.8
12	H30-01-12	Black material shaft end	49	JY21207-01	O-ring, Φ 25x1.8
13	H30-01-13	Piston hold-down nut	50	JY21105-01	O-ring, Φ 12.5x1.8
14	H30-01-14	Coupling part	51	JY21306-01	O-ring, Φ 36.5x1.8
15	H30-01-15	Positioning sleeve of black material shaft coupler	52	J7554-12	O-ring, Φ 14x1.8
16	H30-01-16	Long brace	53	TLB-01-51	O-ring, Φ 19x1.8
17	H30-01-17	Black material shaft	54	JAPS-128	Big ball Φ 17.5
18	H30-01-18	White material shaft	55	JY21208-01	Valve plate
19	H30-01-19	White material seal clamping cap	56	JAPS-133	Small ball Φ 13
20	H30-01-20	Positioning sleeve of white material shaft coupler	57	JAPS-305Y2	Booster pump lifting cup
21	H30-01-21	Short brace	58	J16908-00	Hex socket head bolt M6X16

22	H30-01-22	Left end cap of cylinder	59	J16943-00	Restoring spring of hydraulic lock bolt
23	H30-01-23	Cylinder barrel	60	JFS-110	Booster pump lifting cup support
24	H30-01-24	Right end cap of cylinder	61	Non-metal insert hex lock nut M12	
25	H30-01-25	Cylinder shaft	62		Shaft retainer ring 16
26	H30-01-26	Cylinder piston	63		Spring washer 6
27	H30-01-27	Cylinder guide sleeve	64		Hex socket head bolt M5X16
28	H30-01-28	Guide sleeve gland	65		Spring washer 5
29	H30-01-29	Mounting plate for mechanical switch (left)	66	Non-metal insert hex lock nut M10	
30	H30-01-30	Long screw rod	67		Pipe plug ZG1/2
31	H30-01-31	Cylinder connecting screw rod	68		Hex socket head bolt M5X40
32	H30-01-32	Air guideboard	69		Hex socket head bolt M4X12
33	H30-01-33	Reversal valve connection piece	70		Spring washer 4
34	H30-01-34	Reversal valve seal	71		Hex socket head bolt M4X25
35	H30-01-35	Bottom ball cup	72	Pneumatic reversal valve 4A420-15	
36	H30-01-36	Mounting plate for mechanical switch (right)	73		Mechanical valve S3R-05
37	H30-01-37	Mounting plate for contact switch	74	Contact switch Z15G1704	

For easiest parts selection, visit EquipmentOptionsDirect.com to view our interactive parts selectors.

VIII. JHPK-H30 Schematic Circuit Diagram

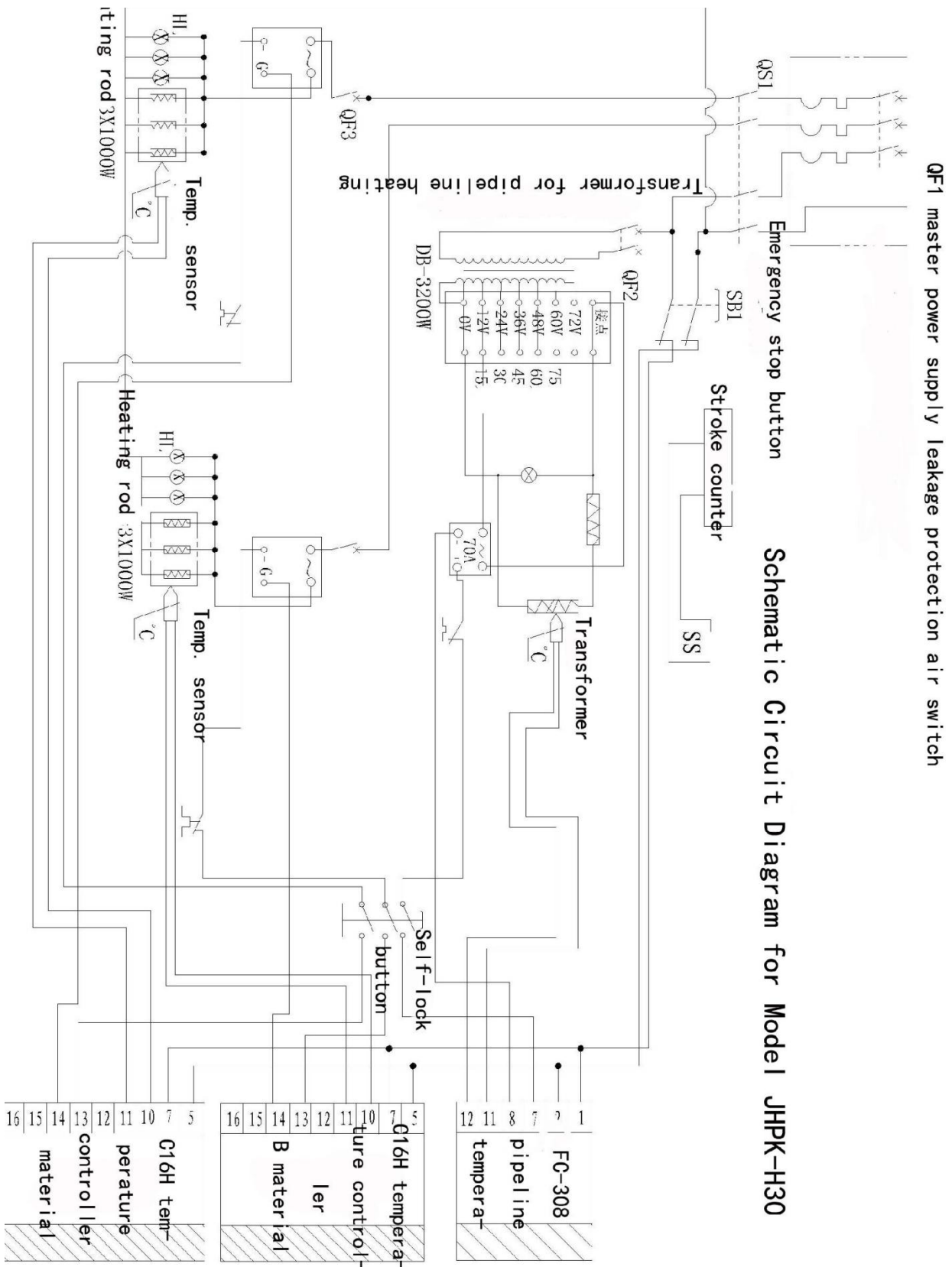

IX JHPK-H30 Control Panel Wiring Diagram

Control Panel Wiring Diagram for Model JHPK-H30

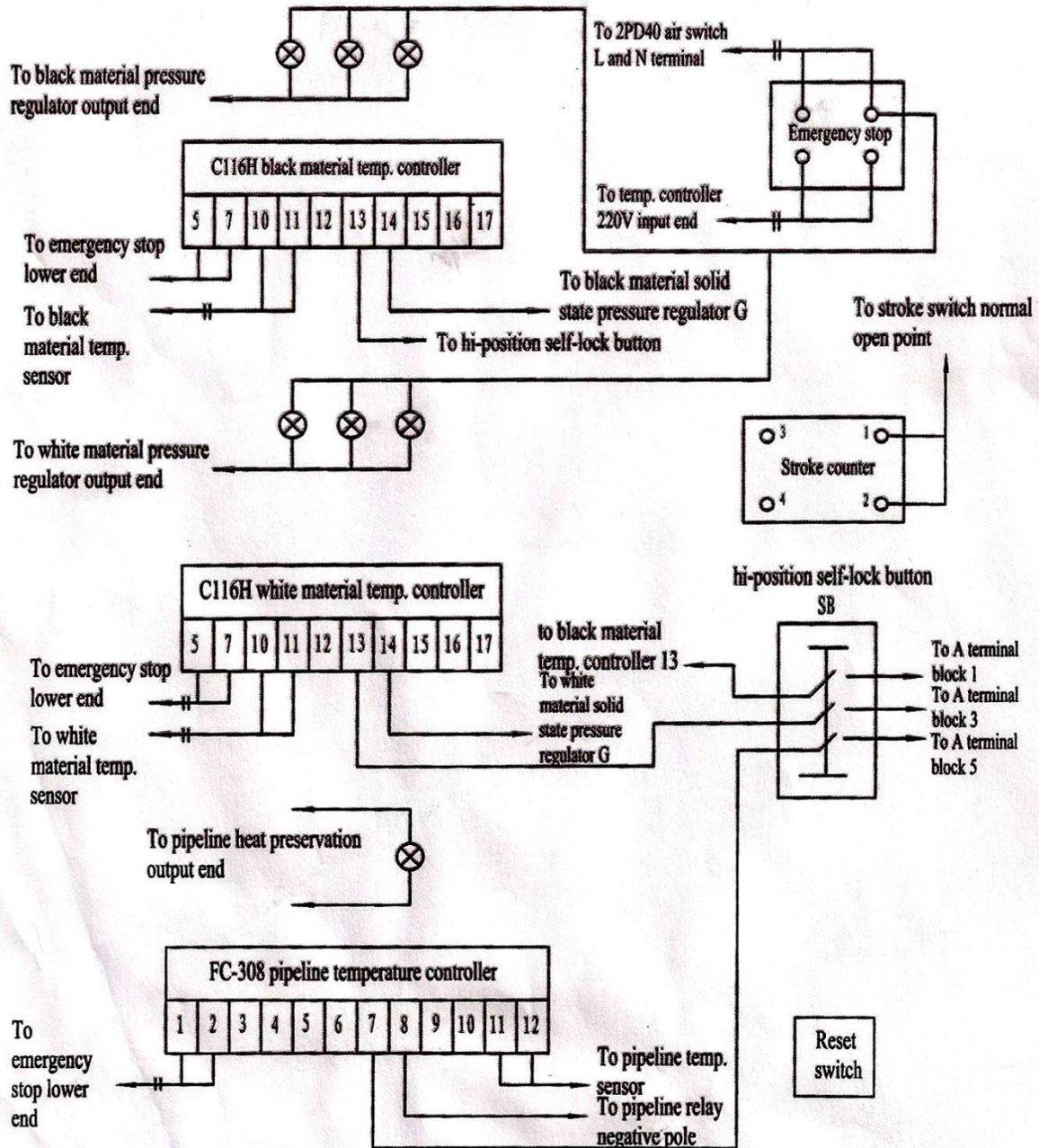

X. JHPK-H30 Electrical Cabinet Wiring Diagram

Electrical Cabinet Wiring Diagram for Model JHPK-H30

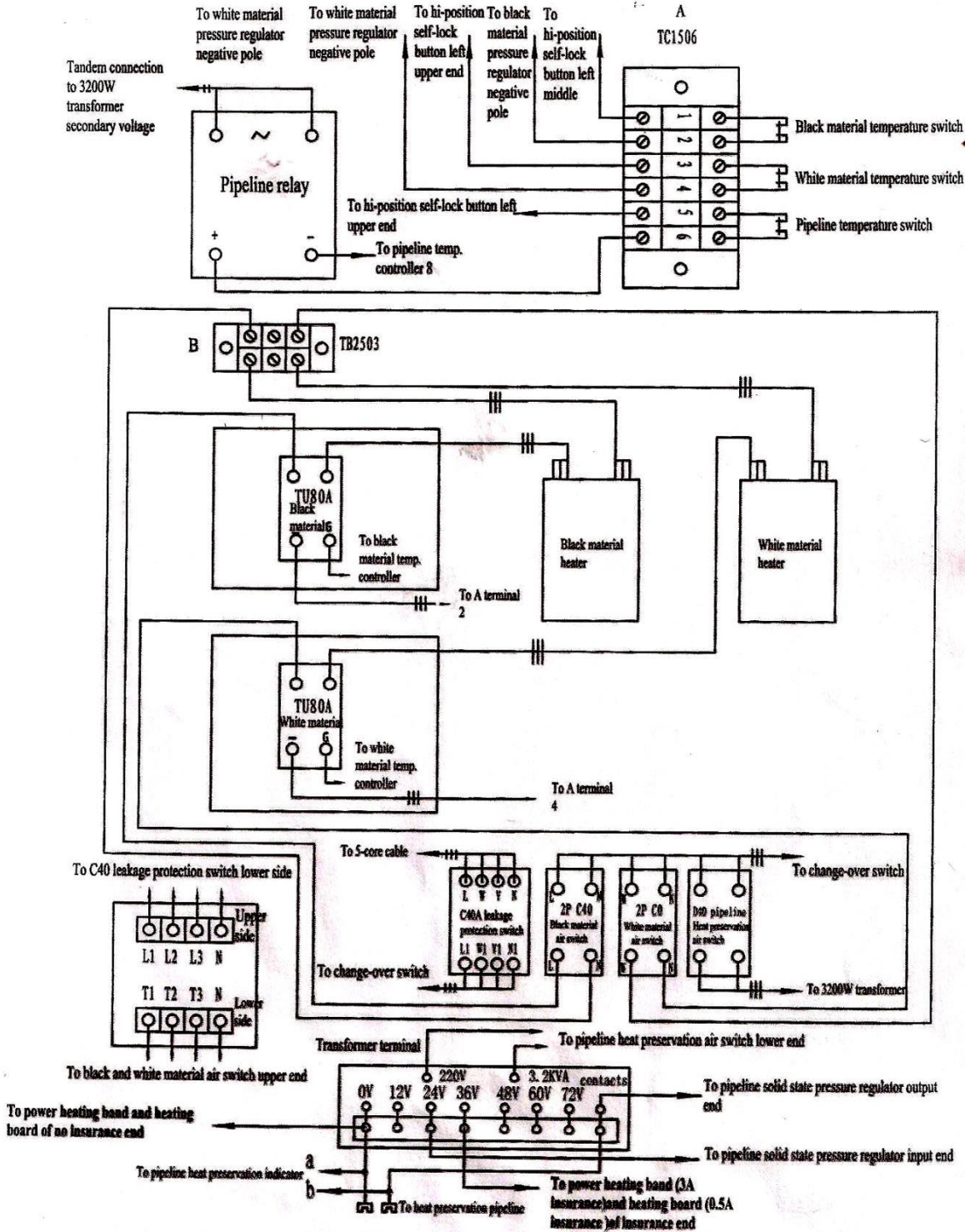

JHPK has obtained the British Royal UKAS in design. Item standard : Q/DXHPK001-20

THANKS FOR PURCHASE OUR PRODUCTS