



A9000

Pneumatic Ultrahigh-pressure Spray Pouring Equipment

Special Waterproof and Anticorrosive

Polyurea Painting Equipment



Brought to you by:









Solutions for the Spray Foam Insulation Industry

Contents

Warning	3
I. JHPK-A9000 raw material flow chart	4
II. Technical data of the system.....	5
III. Diagram of JHPK-A9000 main machine	6
IV. System installation	7
4.1 Installation of raw material pipeline system:	7
4.2 Connection and requirements of air source:.....	10
4.3 Connection and requirements of power source:.....	10
4.4 JHPK-A9000 control panel as shown in Figure (5)	10
4.5 Operation/reset switch:	10
4.6 Scram button:	11
4.7 Heater starting self-lock button:.....	11
4.8 Temperature setting of temperature controller:	12
4.9 General power switch:.....	13
4.10 Electric cabinet:	13
4.11 Overheating protection:	13
4.12 Use of counter	13
4.13 Pneumatic reversing system.....	14
4.14 Large-capacity carrying function of equipment heat preservation pipe group.....	14
V. System operation	15
5.1 Inspection before operation:.....	15
5.2 Initial starting: (in the first installation and use of the new equipment).....	15
5.3 Daily shutdown steps:	17
5.4 Daily maintenance:.....	17
5.5 long-term shutdown treatment:	19
VI. Air pipe connection diagram of pneumatic control system.....	20
VII. JHPK-A9000 circuit schematic diagram	21
VIII. Wiring position diagram of JHPK-A9000 control panel.....	22
IX. Wiring position diagram of JHPK-A9000 electric cabinet	23
X. JHPK-A9000 key part detail form and assembly breakdown diagram	24



Warning

	<p>Hazard of electric shock</p> <p>The improper grounding, incorrect setting or improper use of the system might cause electric shock.</p> <ul style="list-style-type: none"> •Before the equipment maintenance, it's necessary to cut off the general power source of the main machine and the connection with the power line. •It's necessary to ensure the complete grounding of the equipment in the use process. •The equipment shall not be exposed in rainwater, and shall be stored indoors.
	<p>Personal protective articles</p> <p>In the operation and maintenance process of the equipment or the entry into the working area of the equipment, the personnel must wear proper protective articles to prevent serious injury (including eye injury), toxic smoke, burning and hearing loss. These protective articles include but are not limited to the following ones:</p> <ul style="list-style-type: none"> •Goggles; Protective gloves; Hearing protection equipment; Protective clothing and respirator recommended by the fluid manufacturer.
	<p>Hazards of fire and explosion</p> <p>The solvent and painting smoke and other inflammable smokes in the working area might be ignited or explored, and to prevent the fire or explosion, it's necessary to take the following measures:</p> <ul style="list-style-type: none"> •Use and clean the equipment in places with good ventilation. •Keep the working area clean without solvent, fragments, gasoline or other sundries. •If static electric spark or electric shock happens, it's necessary to stop the operation immediately, and do not use the equipment any more before the problem is found out and corrected. •Effective fire extinguisher shall be allocated in the working area
	<p>Hazards of high-pressure aluminum parts</p> <p>1,1,1 – trichloroethane, trichloromethane or other halogenated acetylene solvent or the fluid that contains the solvent of the previous substances shall not be used in the pressurized aluminum equipment, otherwise, intensive chemical reaction or equipment crack will be caused, which might cause serious personal injury and property loss.</p>
	<p>Burning hazard</p> <p>The local area surface of the equipment or the heated fluid might become very hot in the working period, and to prevent the serious burning, it's necessary to not get in contact with the hot fluid or the heating part of the equipment. The personnel can only touch the equipment/fluid after the equipment/fluid is completely cooled.</p>
	<p>Hazards of moving parts</p> <p>The personnel's fingers or other body parts might be clamped or cut by the moving parts.</p> <ul style="list-style-type: none"> • It's necessary to keep away from the moving parts; • Please do not operate the equipment while the protective cover is taken down or the outer cover is removed. • The pressurized equipment can be accidentally started without the warning. It's necessary to cut off the power source and air source before the inspection, movement or maintenance of the equipment.
	<p>Hazard of equipment misuse</p> <p>The misuse of the equipment might cause serious personal injury.</p> <ul style="list-style-type: none"> • The system shall not be used with the parameters exceeding the rated values, please see the technical parameters in the Equipment Manual for reference. • Only the original parts of the manufacturer can be used for the equipment maintenance or replacement, and the equipment shall not be changed. • Hoses and cables shall be kept away from public areas, cutting edges, moving parts and hot surface. • The flexible tube shall not be twisted or excessively bended, or be used for pulling the equipment. • The equipment shall be operated in accordance with all applicable safety regulations.

I. JHPK-A9000 raw material flow chart

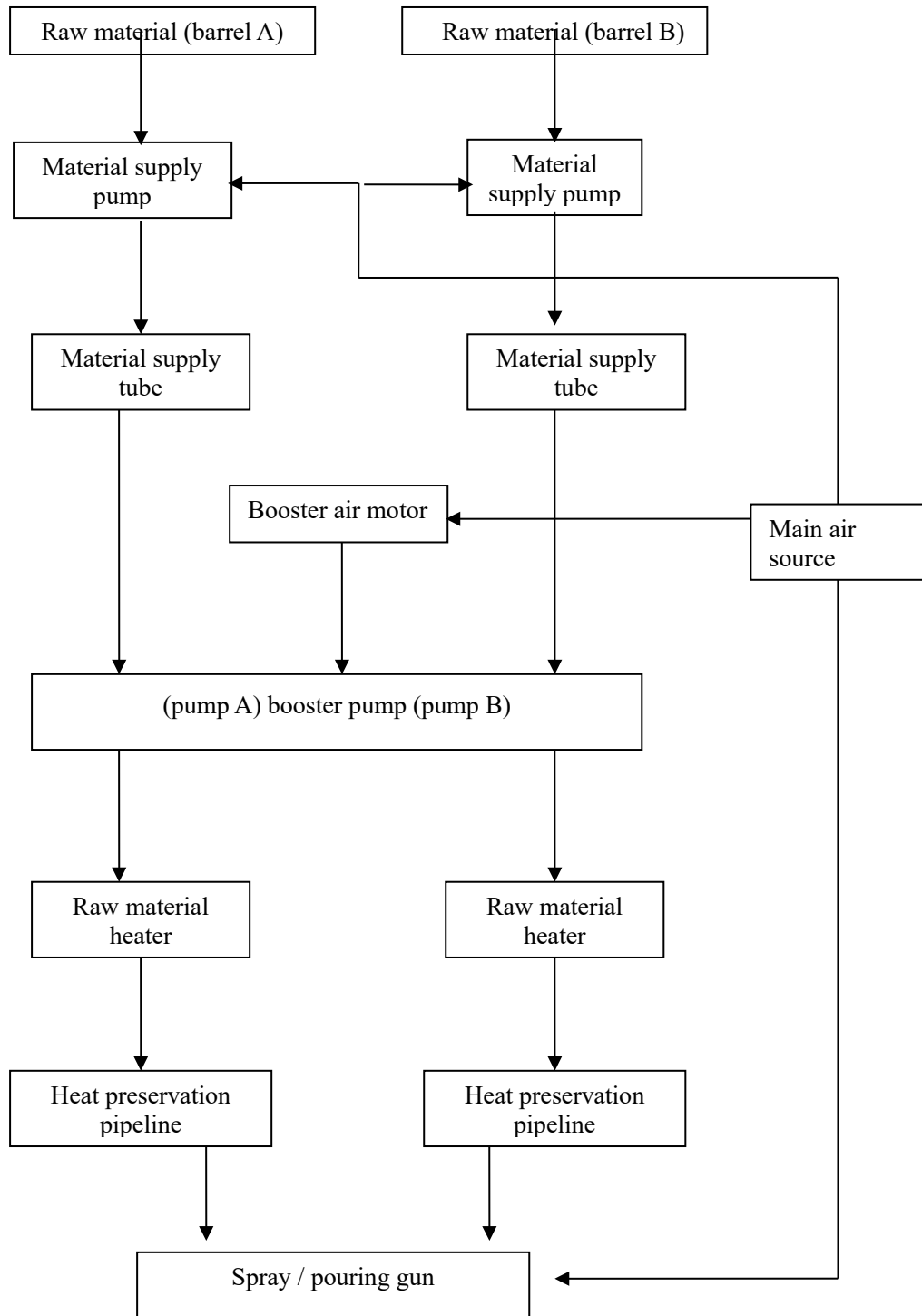

II. Technical data of the system

Standard configuration:

Main machine:	1 set
Special spray gun:	1 (JHPK - PK4 standard configuration)
Material supply pump:	2 (JHPK - 3G76)
Gun connecting short pipe:	1 group 3m
Heat preservation pipeline:	1 group 15m (standard configuration)

Technical parameters:

Raw material proportion:	1:1 Standard fixed proportion
Viscosity scope of raw material:	200~1000CPS (under the operating temperature)
Output of raw material:	2~8Kg/min
Pressure of air source:	0.5~0.8Mpa (70~120psi) $\geq 1.2\text{m}^3/\text{min}$
Power source:	Three-phase four-wire 380V 50HZ 22A×3
Heating power of raw material:	4500W×2
Heat preservation heating power of pipeline:	3200W
Maximum length of heat preservation pipe group:	90m (optional)
Scope of heating temperature:	0°C~70°C
Output pressure of single-component raw material:	9~18Mpa (1300~2500psi)
Spray gun cleaning mode:	Cleaning of pneumatic auxiliary machinery

Shipping parameters:

Appearance dimension:	800mm×800mm×1450mm
Transportation weight:	150Kg

III. Diagram of JHPK-A9000 main machine



Figure (1)

IV. System installation

4.1 Installation of raw material pipeline system:

The isocyanate (black material ISO - A component) and polyhydric alcohols (white material POLY-B component) are transported from the material barrel to the pump body inlet on the main machine through the material supply pump. The raw material and gas pipeline are respectively connected with the special spray-pouring guns according to the following steps:

Attention: Before the installation of the raw material pipeline system, the equipment shall not be in connection with the power source.

(1) Installation of material supply system:

Step 1: open the cover of the material barrel, connect the material pump connector with the material barrel opening, slowly insert the material pump to the bottom of the barrel and lock it tightly.

Step 2: Respectively connect the material delivery pipe ($\Phi 25\text{mm} \times 3000\text{mm}$) with the discharge hole of the material pump and the pump body inlet on the main machine (Figure 2).

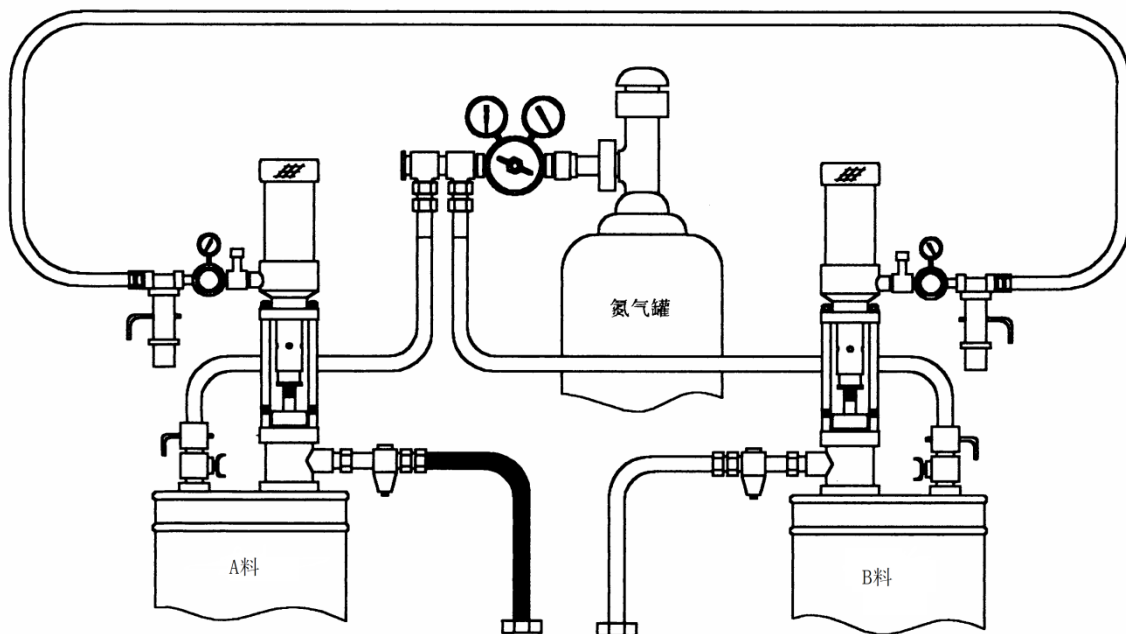

Figure (2)

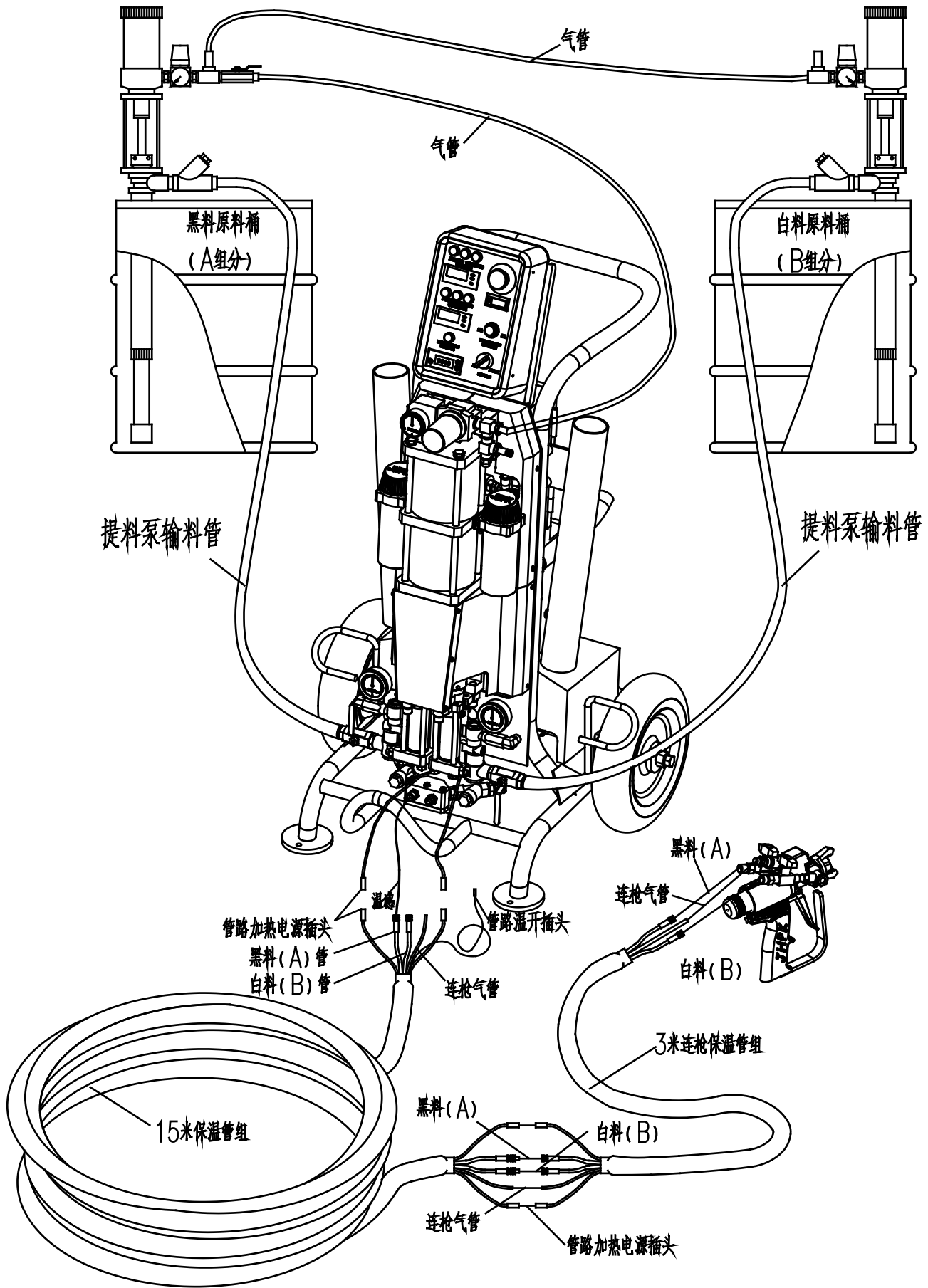

Figure (3)

(2) Installation of material discharging system:

Firstly, the temperature detector (armored lengthened thermocouple, the protective sleeve outside the temperature detector shall be removed in the installation of new machine) at the black material discharging hole on the main machine shall be slowly inserted into the black material pipe from the black material port of the heat preservation pipe group (the pipe head is protruded) completely. In the inserting process, it's necessary to prevent the shell of the temperature detector from hard bending, and to protect the temperature detecting head on the front end of the temperature detector.

Secondly, the raw material is outputted from the heat preservation pipe group and gun connecting pipe group according to the order and connected to the spray / pouring gun through the main machine, and this step is very simple. It's necessary to clarify the pipelines too prevent wrong connection. The connection from the main machine to the material delivery pipe group of PU spray / pouring gun shall be completed as shown in (Figure 3).

(3) Due to the needs of the construction environment, if it's necessary to lengthen the pipeline, the pipelines shall be connected according to Figure (4), and the output voltage of the pipeline heat preservation transformer shall be adjusted to improve the pipeline heating power to meet the power needs of the heat preservation pipeline. The output voltage shall be matched with the length of the pipeline, and in the adjustment, the output voltage shall be selected and the wiring position shall be determined according to the label of "lengthened pipeline wiring position" and the following Table 1.

Attention: the standard factory configuration of this equipment is 15m heat preservation pipeline, and the output voltage of the pipeline heat preservation transformer is 24V.

Table 1

Wiring position	A	B	C	D	E	F
Output voltage of transformer	12V	24V	36V	48V	60V	72V
Pipeline length		15m	30m	45m	60m	75m

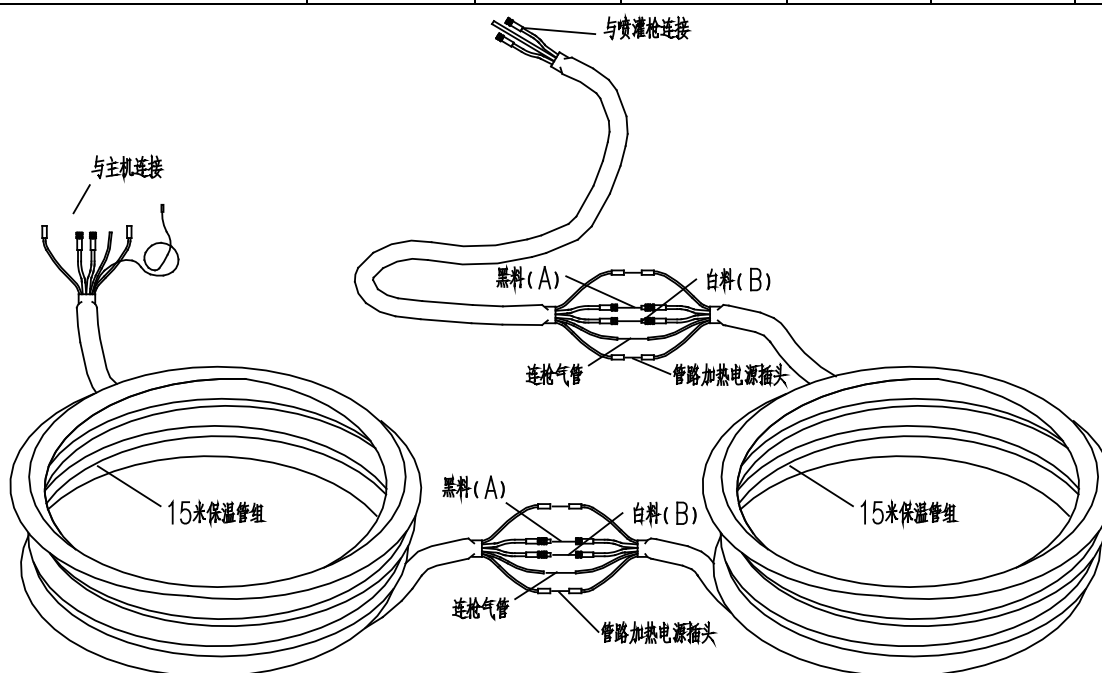

Figure (4)

4.2 Connection and requirements of air source:

The pure compressed air source with the pressure of 0.5 ~ 0.8Mpa and the displacement of 1.2m³ is connected on the port of the gas source inlet on the main machine. The inner diameter of the air pipe shall be more than Φ12mm. If the length of the air pipe is more than 10m, the inner diameter of the air pipe shall be properly enlarged to about Φ20mm to guarantee the air source pressure and flow.

Attention: if the air source is unclean, the sealing system of pressure reducing valve, cylinder, selector valve and other pneumatic components is prone to being damaged. Therefore, it's suggested to install the air filtering equipment and atomized lubricator between the air source inlet and the air source outlet on the equipment to guarantee the service life and motion liquidity of the pneumatic components.

4.3 Connection and requirements of power source:

The end of the five-core power line lead out from the main machine shall be directly connected with 380V and 50HZ three-phase four-line power source. The power of each phase shall be 7KW and the colored cable as the protective grounding cable must be grounded for protection to prevent unnecessary human casualty accidents.

4.4 JHPK-A9000 control panel as shown in Figure (5)

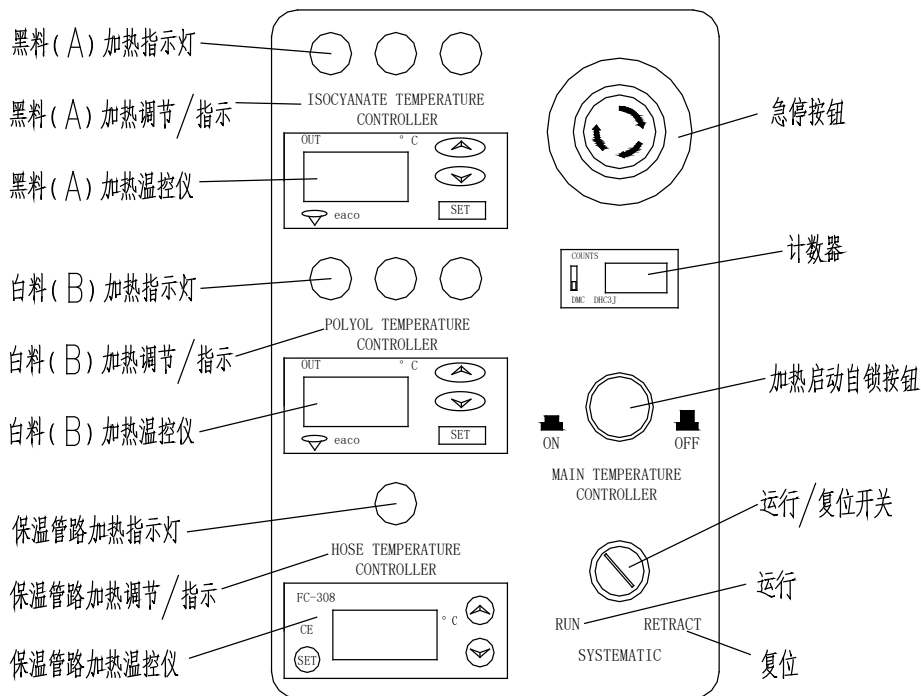

Figure (5)

4.5 Operation/reset switch:



Figure (6)

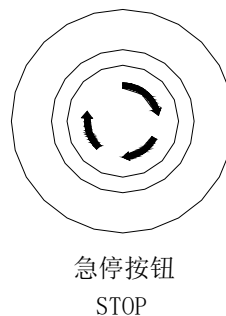

Figure (7)

Concrete operation steps: after the equipment is in connection with the air source, the operation/ reset switch shall be placed at the operation position, and then the booster pump will work normally. If it's necessary to stop the booster pump in short time, the operation/reset switch shall be placed at the reset position. For the long-time stop of the booster pump, the gun machine shall be started to discharge the material (release the pressure) after the operation/ reset switch is placed at the reset position to make the booster pump to continue the work. When the booster pump operates to the designed protection position, it will stop the operation, and at this time, it's necessary to loose the gun and break the air source to the main machine.

The role of the operation/reset switch is to control the work and stop of the booster pump. Meanwhile, when the equipment is stopped, the shaft of the booster pump can be at the lowest end through the operation of the reset switch. The lubricating liquid barrel shall be filled with lubricating liquid. At this time, the working parts of the black material shaft and the lubricating liquid barrel shall be in complete contact with the lubricating liquid and insulated from the air to prevent producing black material crystals and scratching the sealing elements.

4.6 Scram button:

When emergency situation happens on the electric elements of the equipment and it's necessary to stop the operation of the equipment, the scram button can be directly pressed as shown in Figure (7). At this time, all electric elements of the equipment shall be stopped and the button shall be rotated clockwise, and then the button will automatically reset. The electric system of the equipment will recover to the working state.

Attention: only the electric system of the equipment can be controlled through the scram button, and the booster pump of the main machine can continue the operation after the scram button is pressed. If it's necessary to stop the booster pump, the operation/ reset switch shall be placed at the reset position or the air source of the main machine shall be cut off.

4.7 Heater starting self-lock button:

When the general power switch shown in (Figure 8) on the electric cabinet panel on the rear side of the main machine is closed, if it's necessary to charge and heat the black material (A component) and white material (B component), the heater starting self-lock button on the control panel shall be at the low position, that is the power-on position, the control circuit of the temperature controller shall be powered on and the heating system shall be started according to the set temperature. When the heater starting button is at the high position, that is the power-off position, the heating system is unnecessary to work and the high-position self-lock button shall be placed at the high position.

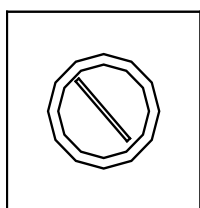

总电源开关
MAIN POWER

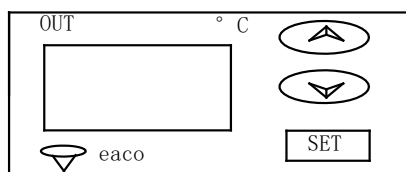

黑料加热调节/指示
ISOCYANATE TEMPERATURE
CONTROLLER

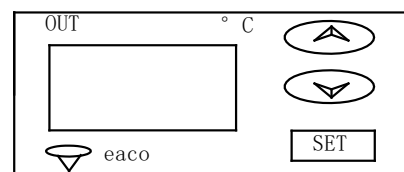

白料加热调节/指示
POLYOL TEMPERATURE
CONTROLLER

Figure (8)

Figure (9)

4.8 Temperature setting of temperature controller:

Three temperature controllers are arranged on the JHPK-A9000 equipment controller dial plate to respectively set and control the temperatures of the black material (A component) heater, white material (B component) heater and pipeline heat preservation heater.

The temperature controller for control of the black and white material heaters is C16H type, with the operation panel as shown in Figure (9). The heating mode of the temperature controller is the power conversion heating. After the confirm button (SET) is continuously pressed for three times under the charged state, the digital pipe will start flickering, press the ▲ key or ▼ key to adjust the heating control temperature to the needed value, then press (SET) key for confirmation. If the digital pipe flickers, it means the setting modification is successful.

The formulas for different raw materials are different (mainly due to the white materials), and the contained components, as well as the heating temperatures are also different. The operator shall understand the characteristics of the used raw materials.

When it's necessary to heat the heat preservation pipeline, the voltage shall be adjusted according to the length (Table 1) and value of the pipeline, and then adjust the heating of the pipeline. The temperature controller for the control of the heat preservation heating of the pipeline is FC - 308 type, and the operation panel shall be as shown in Figure (10).

The temperature controller for the control of the heat preservation heating of the pipeline is FC - 308 type, and the operation panel shall be as shown in Figure (10). The heating mode of the temperature controller shall be the power conversion heating. After the power-on self-inspection, the ▲ key or ▼ key is pressed to enter the temperature set value modification state, and then the set value of the temperature will be flickered on the display window. The set value can be modified through pressing the ▲ key or ▼ key, and the fast adding or reducing can be achieved through pressing the key for long time. After the modification is finished, it's necessary to press SET key for storage and exit. If no key is pressed, the system will save the setting and exit automatically after 10s.

Attention: when the input power frequency is 50HZ, the heating voltage of the pipeline shall be adjusted according to different connection length of the pipeline, which shall not exceed the voltage value specified in (Table 1), otherwise the pipeline heating control module will be started frequently, which will affect the service life of the pipeline.

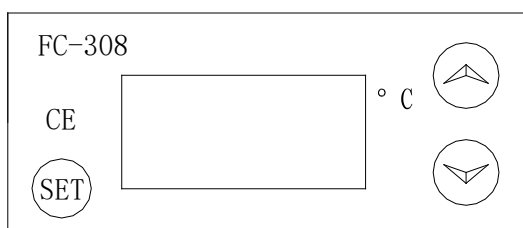

管路加热调节/指示
HOSE TEMPERATURE
CONTROLLER

Figure (10)

Attention: C16H type temperature controller and FC-308 temperature controller are multifunction controllers. If you want to adjust the temperature randomly, the improper operation might cause the deadlock of the temperature controllers.

4.9 General power switch:

In this equipment, the power switch on the door panel of the electric cabinet is the isolation switch that controls all electric switches, but is incapable of controlling the concrete switch-off of certain procedure. If it's necessary to break the power source of certain circuit, the door panel of the electric cabinet shall be opened to control the opening and closing of the power source air switch of the circuit.

Attention: when the general power switch is open, all electric appliances on the control panel will not be electrified, but the input power line and the cable from the input power line to the main switch are still electrified. Therefore, even the general power switch is closed, it's necessary to remove or cut off the external general power source in the internal maintenance of the instrument panel.

4.10 Electric cabinet:

The electric cabinet shall be arranged on the rear portion of the equipment. The general power switch is installed on the protruding portion outside the door plate to facilitate the operation of the switch. After opening the door plate of the electric cabinet, we can see a group of wiring terminals at the inner bottom of the cabinet body. The relative output voltage can be adjusted according to the length of the material pipe of the equipment.

Totally four air switches in two rows are arranged on the inner side of the door plate of the electric cabinet, including the black material heating switch and white material heating switch from left to right on the upper row, the general power source electricity leakage protector and heat preservation pipe group heating switch on the lower row. All these switches are in closed state before they leave the factory. When one procedure is switched off, corresponding air switch might trip, at this time, it's necessary to open the door plate of the electric cabinet to inspect the problem, and then close the air switch after the inspection.

Attention: The operation of the electric cabinet shall be carried out by professional electricians or the trained operators.

4.11 Overheating protection:

The JHPK-A9000 type equipment, main machine heater and heating pipeline are provided with the overheating temperature protection circuits. When the actual temperature is more than 70°C, the heating control power source will be automatically opened. If the raw material heater and heat preservation pipeline are not heated in the operation process, the power source of the overload protection circuit might be broken, and under such situation, it's necessary to firstly judge the actual temperature of the raw material to check it's higher than the set value or the set value of the temperature is too high. If it is, the heating system will automatically recover after the temperature is reduced.

4.12 Use of counter

The flow of the PU foaming machine produced by our Company is calculated through the counter and the flow of the double-component raw materials discharged from through the moving back and forth for one time of the booster pump is $64.3 * 2 = 128.6\text{mL}$, and at this time, the counter is considered as being operated for one time. Through the accumulation operation of the counter, the raw material discharged in certain time section can be calculated.

Adjustment of counter: one switch capable of moving upwards and downwards is arranged beside the display digits. If the switch is placed to the upper position, the zero clearing function will be executed after the button is pressed, and the switch placed at the lower position will execute the locking function, as shown in Figure (11).

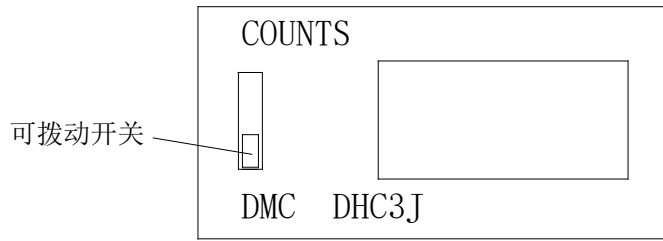

计数器

Figure (11)

4.13 Pneumatic reversing system

The reversing mechanism of the booster pump is composed of a series of mechanical valves and main valves, and the switching of the gas circuit is achieved through the contact and separation of the special parts on the booster pumps with the mechanical valves. The reversing action is guaranteed through adjusting the collision position of the contact blocks. The gas circuit and connecting gas pipe are in different colors for discrimination. In the installation and maintenance, the gas pipes in different colors are connected with the ports in corresponding colors. The mechanism is characterized by flexible and reliable operation, low fault rate, convenient installation and maintenance and the like.

4.14 Large-capacity carrying function of equipment heat preservation pipe group

Figure (12) shows the diagram of the winding and gathering heat preservation pipe group for the main machine of JHPK-A9000 type equipment. In the figure, a spatial rack is formed by the extending pipe on the main machine bracket, the arced protection ring on the front end and the fence on the walking places on the two sides, and the heat preservation pipe group can be wound or gathered around the equipment through the spatial rack. This equipment can carry four 15m standard heat preservation pipe groups at most.

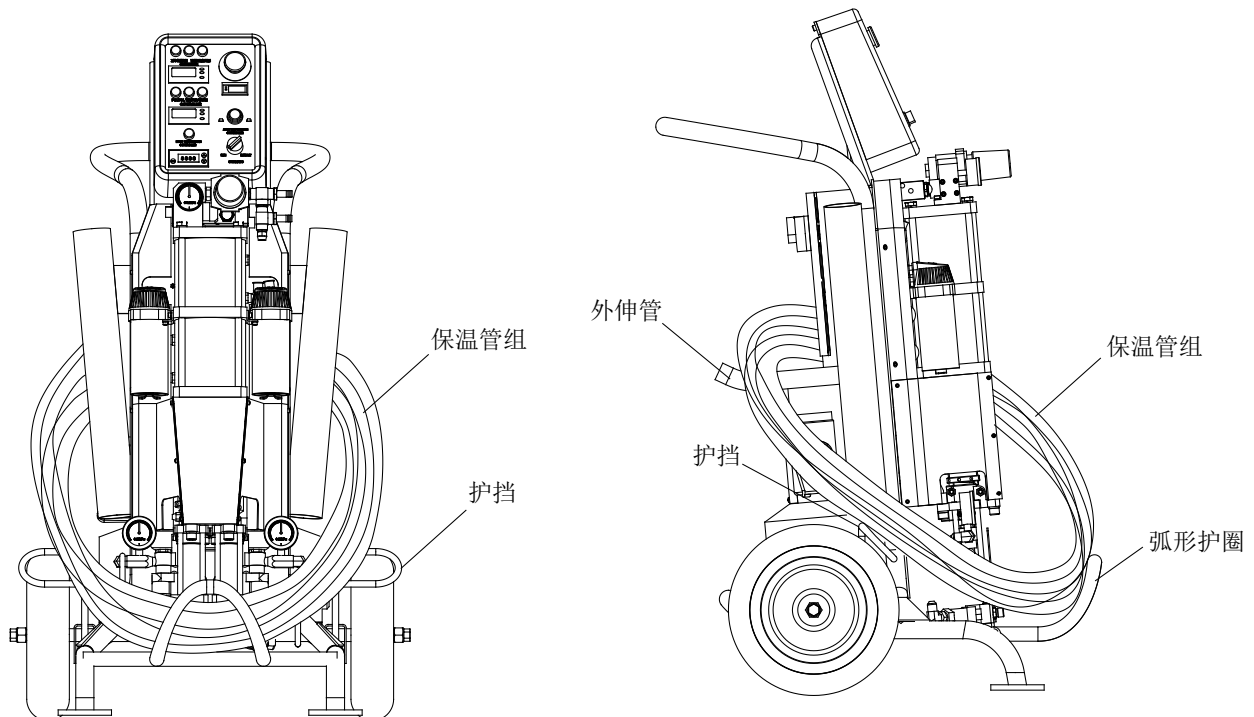

Figure (12)

The layout of the equipment is arranged in full consideration of the spatial use to guarantee the space for the designed movement that one operator can move the equipment. The fulfillment of the large-capacity carrying function of the equipment heat preservation pipe group greatly increases the adaptability of the equipment, and greatly facilitates the operators, both saves the labor force and improves the efficiency.

V. System operation

5.1 Inspection before operation:

5.1.1 Inspect whether the anti-sticking lubricating liquid storage tank contains the DOP (o-diethyl phthalate) with the volume no less than 1/5 of the liquid volume.

5.1.2 Inspect whether all joints are tightly fastened.

5.1.3 Inspect whether the power line connection is correct. Whether the protective grounding line is safe and reliable.

5.1.4 Inspect whether all switches on the control instrument panel are at the OFF position.

5.1.5 Inspect whether the air source adjusting valve is at the OFF position.

Pay attention to keeping any part of your body out of the spraying scope, not aligning the gun at any people or looking into the small hole in the gun mixing chamber. Since the raw materials contain harmful components, the operators are suggested to wear masks, gloves, goggles, protective clothing and other protective tools in the spraying process.

Before operation, the operators shall read the warning part on the front page of this Instruction Manual carefully.

5.2 Initial starting: (in the first installation and use of the new equipment)

After it's confirmed that all the liquid pipes, air source pipes and power lines are correctly connected, the system operation will be started. At this time, the operator must complete understand the functions of all parts on the control instrument panel, and take necessary protective measures.

The steps are as follows:

Step1: Open the general power switch of the main machine, adjust the main air source pressure and rotate the material supply pump pressure adjusting valve to adjust the pressure to 0.2Mpa.

Step2: place the operation/ reset button at the operation position, and at this time, the main machine will start the operation to fill the material circuit system and heating pipeline with raw materials. Once the system and heating pipeline are filled with the raw materials, the equipment will automatically stop the operation.

Step3: remove the two material delivery blocks on two sides of the spearhead chamber.

Step4: Respectively place on clean container under each material delivery block, at the same time, slowly open the raw material valves on the two material delivery blocks to release the air in the material delivery pipes completely, till the raw materials are stably sprayed out from the pipes. See Figure (13)

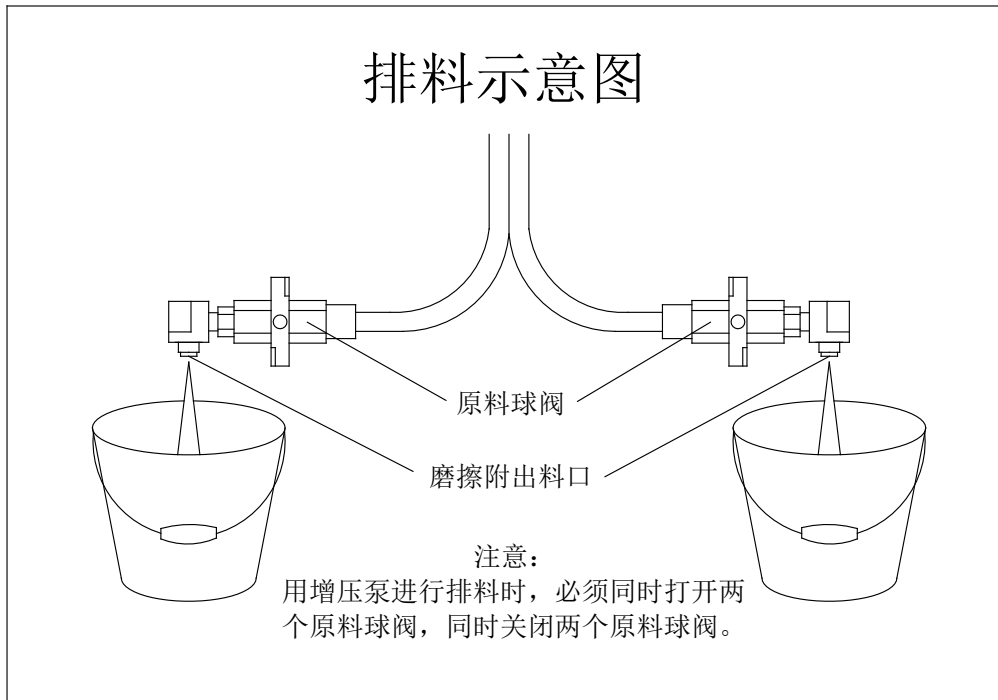

Figure (13)

Step5: Synchronously close the two raw material valves, and at this time, the pressure values indicated on the raw material pressure meter shall be approximately equal. If the pressure of one circuit is slightly higher, the raw material valve on the material delivery block with the slight higher pressure shall be lightly opened to flow out the raw materials till the pressures of the two flows are approximately equal.

Step6: the waste materials shall be treated reasonably and safely.

Step7: Clean the residual raw materials on the material delivery blocks, paint the lubricating grease on the blocks and reassemble the gun body on the material delivery block. Stably fasten the crews on the material delivery blocks.

Step8: straighten the material delivery pipe group to prevent the uneven heating or damage of the heating wire in the pipeline, place the heating starting self-lock button at the low position to switch on the heating system.

Step9: respectively set the heating temperatures of the black material heater and the white material heater, and the heating temperature of the heat preservation pipeline according to the introduction on the temperature setting of temperature controllers in Section 4.8. After the temperature reaches the set value, the air source pressure of the main machine can be raised to the working pressure.

Attention: since the compound polyhydric alcohols will swell in the heating process, the air source pressure of the main machine shall not be the working pressure before the spray pouring of the JHPK-A9000 system to prevent the raw materials in the pipe from heating and causing too high pressure and damaging the pressure meter, even causing explosion.

Step10: adjust the air source pressure valve of the main machine to adjust the air source pressure to 0.5-0.7Mpa. (Reference value)

Step11: firstly open the air inlet switch on the gun body, and then open the raw material valves on the two material delivery blocks.

Step12: at this time, the preparation works of the whole system are completely, and the spraying can be started through pulling the trigger.

Attention: if you stop the operation, please make sure to close the raw material valves on the two material delivery blocks to prevent the misoperation and causing the ejection of raw materials.

5.3 Daily shutdown steps:

Attention: when shutting down the machine, the operation/ reset switch shall be placed at the reset position, and the trigger shall be pulled to discharge the material (release the pressure), and make the booster pump to continue the work. When the booster pump operates to the designed protection position, it will stop the operation, and at this time, it's necessary to loose the gun and break the air source to the main machine finally.

At this time, it's necessary to inspect the spray gun to prevent the sealing parts in the gun from being damaged and causing the leakage of raw materials from the gun after the gun is stopped, solidifying the raw materials in the gun body and causing the failure on secondary operation of the spray gun.

Shutdown steps:

Step 1: press the heating starting self-lock button to place it at the high position, and then the heating system will be stopped.

Step 2: inspect the spray gun. The next step can be carried out after the spray gun is confirmed to be correct and can guarantee the secondary normal operation. Otherwise, it's necessary to carry out the cleaning, maintenance and inspection steps of the spray gun, see the *Spray Gun Use Instruction* for the cleaning and maintenance of the spray gun.

Step 3: place the operation/reset switch at the reset position, pull the trigger to discharge the material (release the pressure) to make the booster pump to continue the operation. When the booster pump operates to the designed protection position, it will stop the operation, and at this time, the gun shooting shall be stopped.

Step 4: close the general power switch of the main machine;

Step 5: close the air source of the main machine, and at this time, the pressure indicated on the air pressure meter in the equipment shall be zero;

Step 6: clean the working site and confirm that the daily shutdown steps are completed. Inspect whether the quantity of the residual raw materials meets is enough for the secondary starting up to prepare for the secondary work.

5.4 Daily maintenance:

5.4.1 Supplementation and replacement of lubricating liquid

The lubricating liquid DOP (o-diocetyl phthalate) can prevent the raw material from crystallizing on the booster pump shaft and prevent the damage and destruction of the sealing part, therefore it's necessary to observe and maintain the lubricating liquid at real time.

- It's necessary to regularly supplement the lubricating liquid or replace the lubricating liquid with the colors that changed seriously to guarantee the capacity of the lubricating liquid no less

than 4/5 of the capacity of the storage tank.

- If the lubricating liquid turns into gel state and a great number of flocculent sediments appear, it's necessary to replace the lubricating liquid.
- If the color of the lubricating liquid turns dark slowly, it's the normal phenomenon since a few amount of raw materials constantly leak out through the sealing parts in the operation process of the equipment. However, if the color of the lubricating liquid turns dark in short time, it's necessary to stop the machine immediately, and properly rotate the booster pump sealing cover and replace the lubricating liquid before continuing the work (see 6.4.2 for reference).
- It's necessary to regularly clean the check valve to guarantee the liquid flow is unblocked.
- Attention: the return pipe in the liquid storage pipe must reach the bottom of the liquid storage tank and the opening of the liquid feeding pipe shall be 1/3 length to the bottom of the liquid storage tank, see Figure (14).
- The lubricating liquid feeding pipe shall be connected with the upper port of the material discharging end block, and the lubricating liquid return pipe shall be connected with the lower port of the material discharging end block.
- The waste material shall be specially treated to prevent damaging the environment.

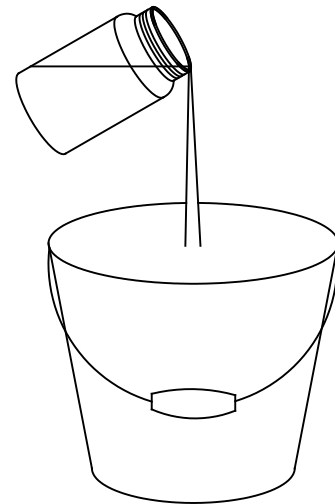
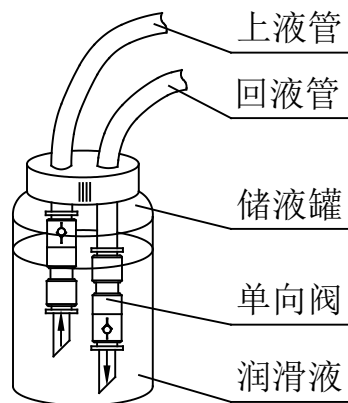

箭头所示方向为润滑液流动方向

Figure (14)

5.4.2 A layer of grease shall be evenly painted on the cylinder shaft regularly.

5.4.3 The inspection and maintenance of the spray gun shall be completed according to the spray gun inspection steps in the daily shutdown steps.

Attention: the pressurized equipment can be accidentally started without the warning. Before the inspection, movement or maintenance of the equipment, it's necessary to cut off the power source and release all air pressure and hydraulic pressure.

5.5 long-term shutdown treatment:

5.5.1 Method I:

This is the measure taken in a relatively short time for the equipment storage. The steps are as follows: (on the premise of the raw material in the raw material barrel)

Step 1: switch on the main air source (at this time, it's unnecessary to switch on the main machine), open the material supply pump adjusting valve to adjust the air source pressure to 0.1—0.2Mpa.

Step 2: rotate the main machine pressure adjusting valve to adjust the pressure to 0.2Mpa.

Step3: remove the two material delivery blocks on two sides of the spearhead chamber.

Step 4: place the operation/ reset switch at the operation position, carry out the return operation of the raw material and fill the system flow circuit with the new liquid.

Step 5: shut down the machine according to the daily shutdown steps.

Instruction: this procedure shall be carried out once in 15d to prevent the black materials (isocyanate ISO) from crystallizing.

5.5.2 Method II:

This operation is applicable for the measures taken under the situation that the machine is out of operation for long time, such as winter shutdown or uncertain service time. The operation steps are as follows: (mainly due to isocyanate)

Step 1: take out the raw material barrel from the material supply pump and remove the raw materials on the outer wall of the material supply pump.

Step 2: put the material supply pump into a clean solvent container. Open the material supply pump adjusting valve to adjust the air source pressure to 0.1-0.2Mpa.

Step3: switch on the air source of the main machine and adjust the air source pressure of the main machine to 0.1-0.2Mpa.

Step 4: open the raw material valve to respectively spray the residual materials in the equipment system into one proper container till the clean solvent appears. This step is used to clean the raw materials in the system with the solvent.

Step 5: put the material supply pump into the DOP (o-diethyl phthalate) protection liquid container.

Step 6: start the equipment, then the system starts the circulation for 2-5min; close the ball valve to make the equipment material pipeline filled with DOP solvent, and keep the pressure of 1- 2 MPa.

Step 7: shut down the machine according to the daily shutdown steps, seal all feeding holes and discharging holes to store the materials.

VI. Air pipe connection diagram of pneumatic control system

阀体及接头规格参数对照表

名 称	规 格	数 量
气动换向阀(主阀)	4A420-15	1
机械阀	S3R-05	2
复位开关 (控制组合头)	S3HS05-P13	1
	S3HS05	1
1-快插接头-螺纹弯通	ZG1/8- $\phi 6 \times \phi 4$	2
2-卡套式螺纹直通	M5- $\phi 6 \times \phi 4$	6
3-卡套式螺纹弯通	M5- $\phi 6 \times \phi 4$	2

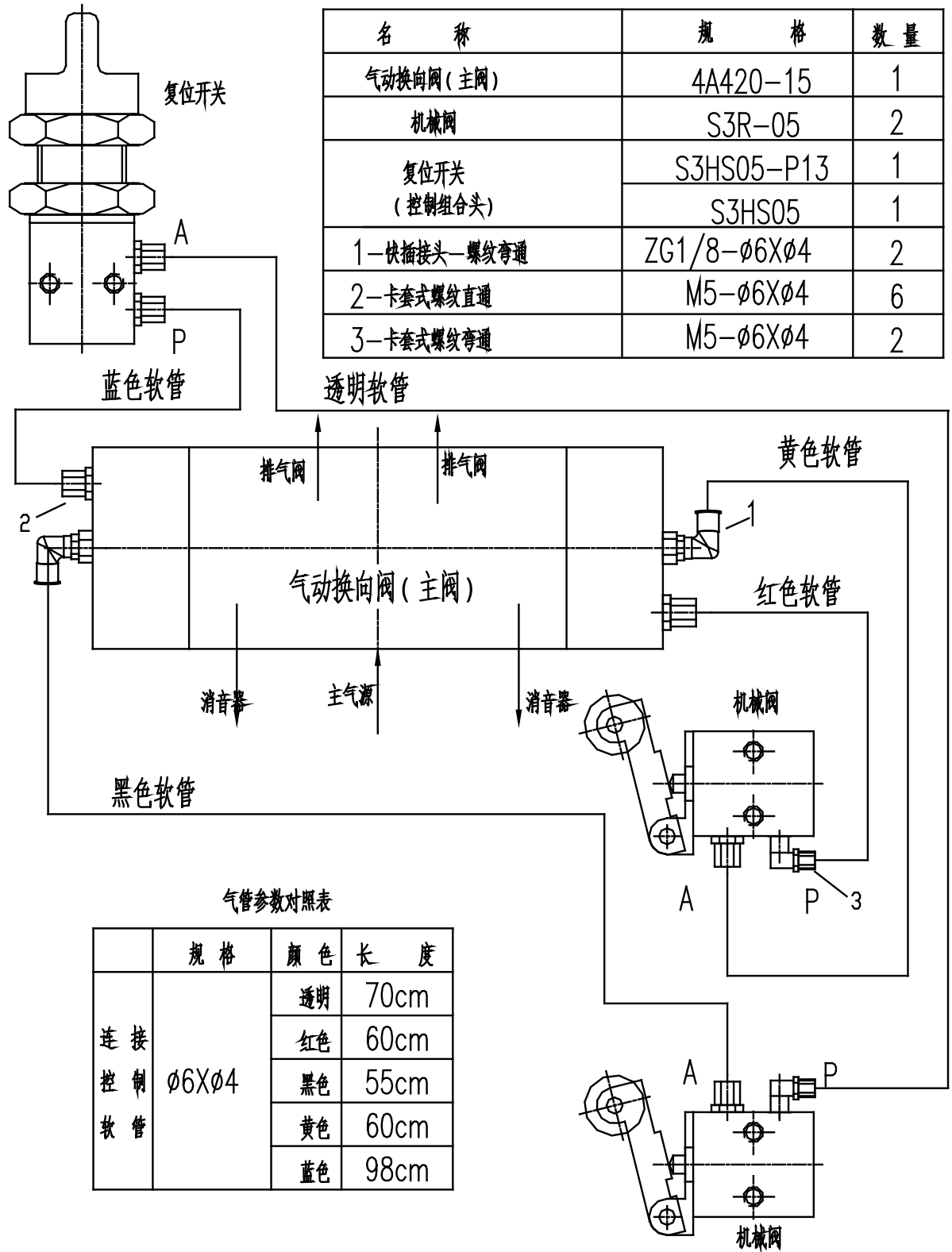

气管参数对照表

	规格	颜色	长度
连接 控制 软管	$\phi 6 \times \phi 4$	透明	70cm
		红色	60cm
		黑色	55cm
		黄色	60cm
		蓝色	98cm

VII. JHPK-A9000 circuit schematic diagram

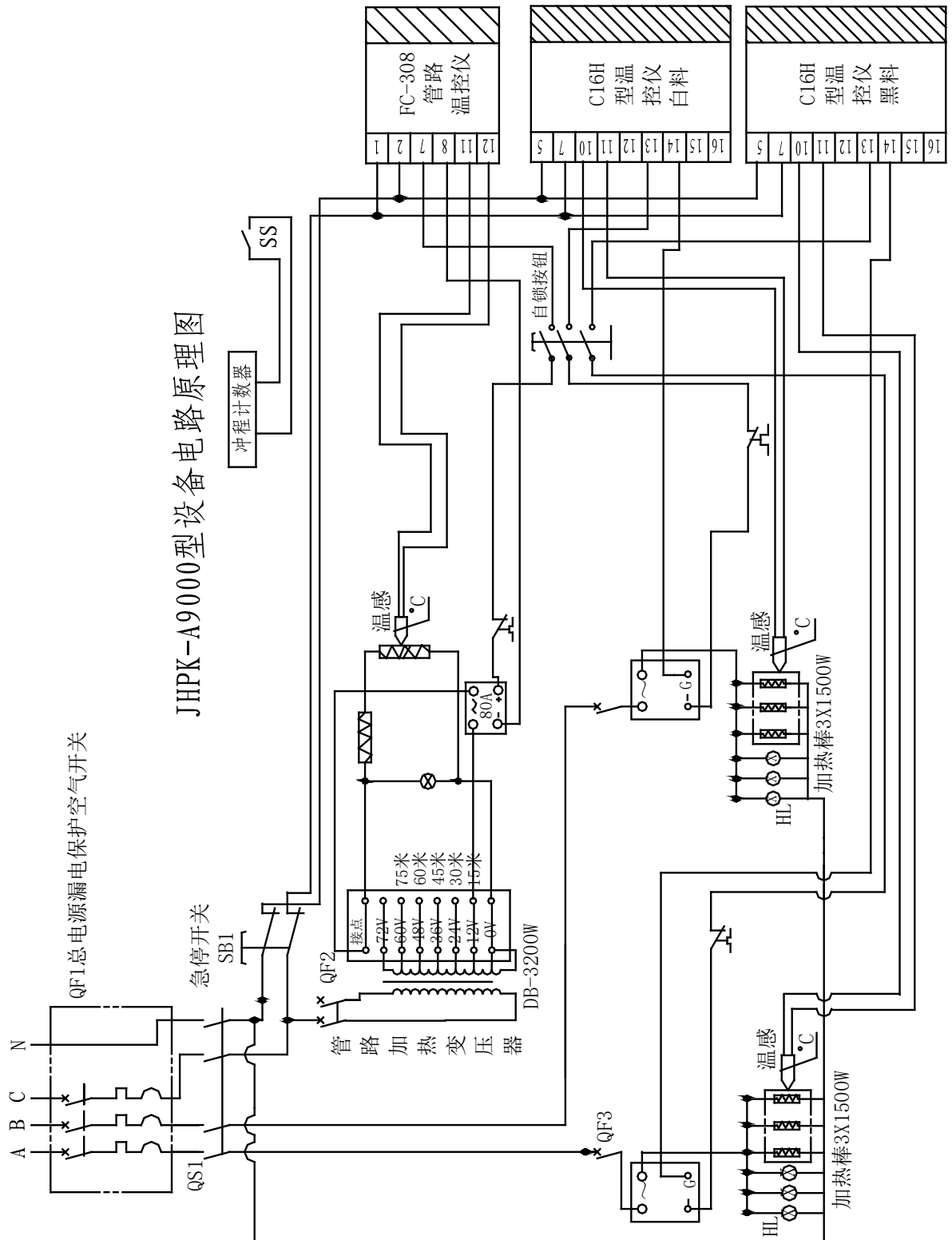

VIII. Wiring position diagram of JHPK-A9000 control panel

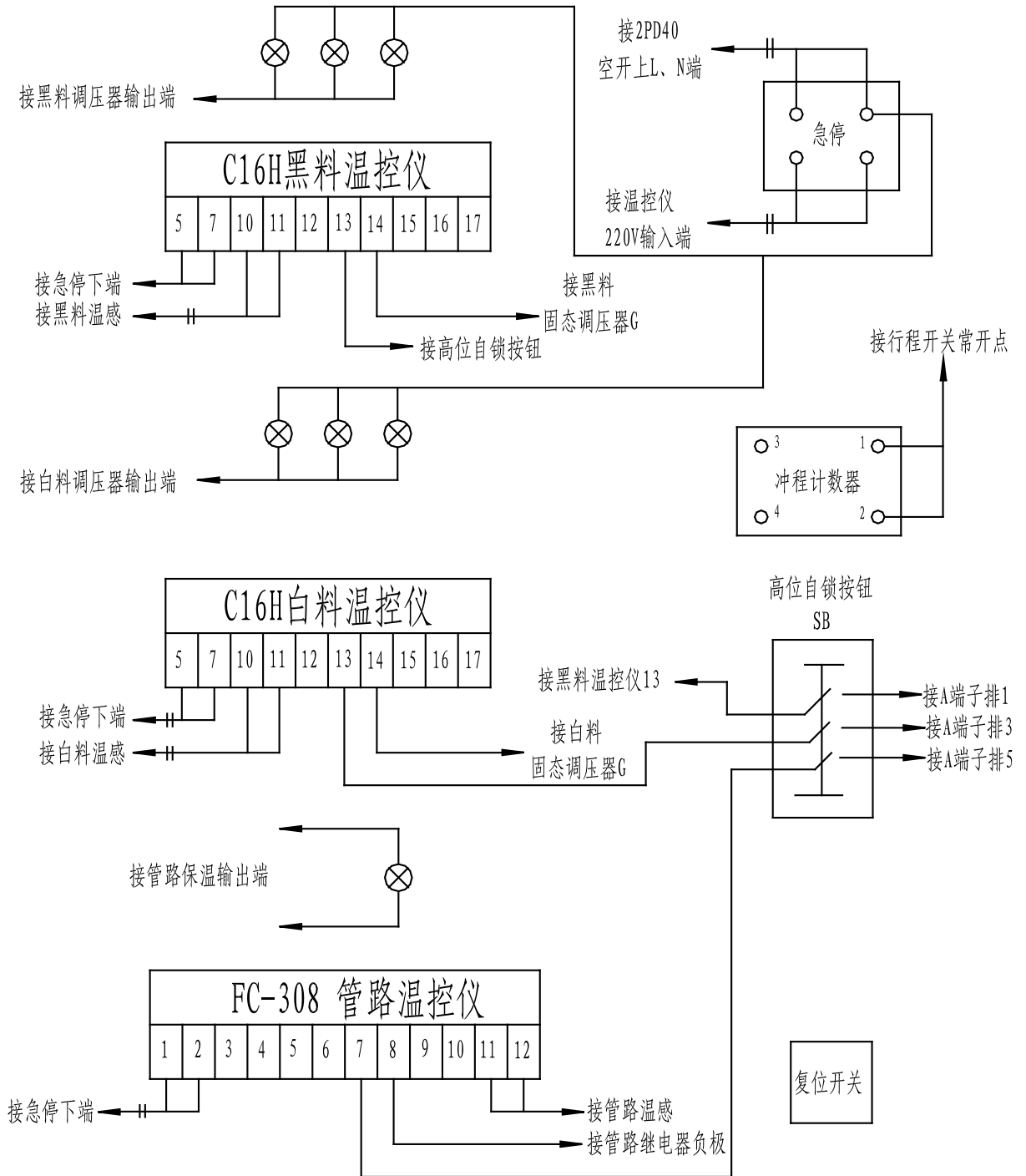

IX. Wiring position diagram of JHPK-A9000 electric cabinet

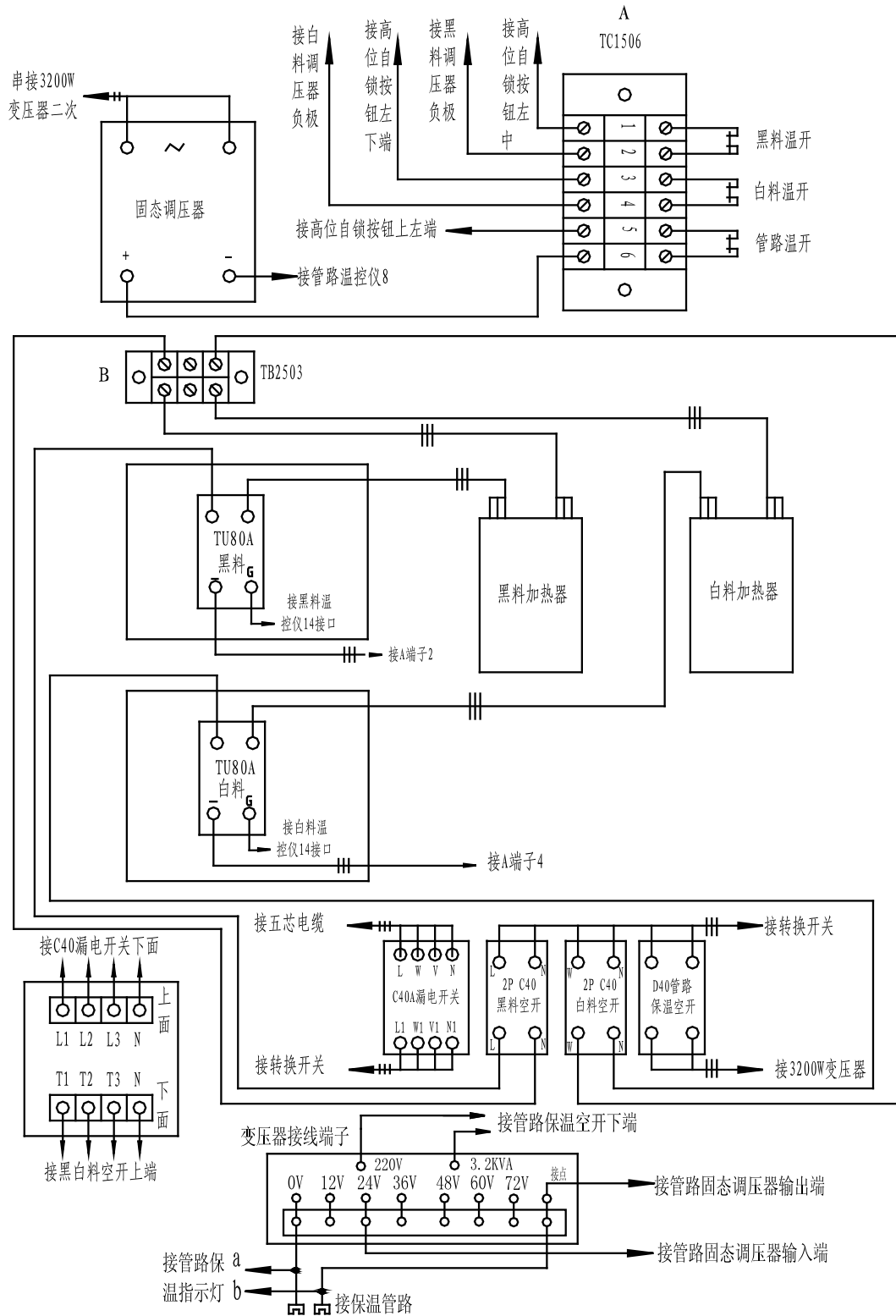

X. JHPK-A9000 key part detail form and assembly breakdown diagram

Double-piston cylinder part table

Serial	Part No.	Part name	Number
1	A9-06-01	Upper cover of cylinder	1
2	A9-06-02	Piston fastening bolt	1
3	A9-06-03	Piston	2
4	A9-06-04	Cylinder barrel	2
5	A9-06-05	Piston shaft	1
6	A9-06-06	Cylinder guide copper sleeve	1
7	A9-06-07	Lower cover of cylinder	1
8	A9-06-08	Guide sleeve pressing cover	1
9	A9-06-09	Sealing ring (for piston)	4
10		Inside hexagonal bolt M6 * 12	4
11		Elastic washer 6	4
12		Nut M16 * 1.5	1
13		Elastic washer 16	1
14	A9-06-10	Pneumatic dustproof draw bar	3
15	JY21202-01	O-ring 34.5 * 1.8	1
16	H30-01-39	O-ring 118 * 2.65	4
17	JY21207-01	O-ring 25 * 1.8	2
18	A9-06-11	Cylinder draw bar M12 * 340	4
19		Elastic washer 12	4
20	J7554-12	O-ring 14 * 1.8	1
21	A9-06-12	Piston lengthened shaft	1
22	A9-06-13	Intermediate bulkhead	1
23	A9-06-14	Sealing steel washer	1
24			

[Visit Equipment Options Direct for parts](#)

Black material booster pump part table

Serial No.	Part No.	Part name	Serial No.	Part No.	Part name
1	A9-04-01	Booster pump shaft	24	JAPS-128	Steel ball ϕ 17.5
2	A9-04-02	Oil cup piston	25	JAPS-133	Steel ball ϕ 13
3	A9-04-03	Oil cut spring	26	J16943-00	Hydraulic gun shooting reset
4	A9-04-04	Anti-sticking oil cup	27	JY13867-43	O-ring ϕ 31.5 \times 1.8
5	A9-04-05	Black material discharging end block	28	JAPS-138	O-ring ϕ 27 \times 1.9
6	A9-04-06	Booster pump lower end block	29	JY21218-00	Small ball sealing compression
7	A9-04-07	Large ball filling bowl	30	J7554-12	O-ring ϕ 14 \times 1.8
8	A9-04-08	Material feeding return valve	31	JY21206-01	O-ring ϕ 22.4 \times 1.8
9	A9-04-09	Small ball valve ring	32	JY21306-01	O-ring ϕ 36.5 \times 1.8
10	A9-04-10	Small ball feeding bowl	33	JY21104-01	O-ring ϕ 40 \times 2.65
11	A9-04-11	Small ball feeding sealing wire block	34		Check ring for hole 47
12	A9-04-12	Booster pump draw bar	35		Y-ring 22*30*4.5
13	A9-04-13	Small sealing part for valve body	36		Wire block ZG1/4
14	A9-04-14	Large sealing part for valve body	37		Wire block ZG1/8
15	JAPS-305Y-02	Booster pump compression ring	38		Wire block ZG1/16
16	JAPS-305Y	Sealing bowl component	39		Elastic washer 10
17	JAPS-305Y-01	Booster pump supporting ring	40		Inside hexagonal bolt M12 * 30
18	H30-01-05	Material barrel	41		Elastic washer 12
19	H30-01-09	Material feeding bowl installation base	42		Inside hexagonal bolt M5 * 16
20	JAPS-305Y2	Booster pump feeding bowl	43		Flat washer 5
21	JFS-110	Booster pump feeding bowl holder	44		Elastic washer 5
22	H30-01-08	Feeding bowl pressing bolt	45		Inside hexagonal bolt M6 * 20
23	H30-01-38	Large ball valve block (ϕ 26 \times ϕ 13)	46		

[Visit Equipment Options Direct for parts](#)

White material booster pump part table

Serial No.	Part No.	Part name	Serial No.	Part No.	Part name
1	A9-05-01	White material discharging end block	24	JY21218-00	Small ball sealing compression ring
2	A9-04-01	Booster pump shaft	25	J7554-12	O-ring $\phi 14 \times 1.8$
3	A9-04-06	Booster pump lower end block	26	JY21206-01	O-ring $\phi 22.4 \times 1.8$
4	A9-04-07	Large ball filling bowl	27	A9-04-13	Small sealing part for valve body
5	A9-04-08	Material feeding return valve	28	JP33-14	Booster pump oil cup
6	A9-04-09	Small ball valve ring	29		Wire block ZG1/4
7	A9-04-10	Small ball feeding bowl	30		Wire block ZG1/8
8	A9-04-11	Small ball feeding sealing wire block	31		Wire block ZG1/16
9	A9-04-12	Booster pump draw bar	32		Elastic washer 10
10	JAPS-305Y-02	Booster pump compression ring	33		Inside hexagonal bolt M12 * 30
11	JAPS-305Y	Sealing bowl component	34		Elastic washer 12
12	JAPS-306Y-01	Booster pump supporting ring	35		Inside hexagonal bolt M5 * 16
13	H30-01-05	Material barrel	36		Flat washer 5
14	H30-01-09	Material feeding bowl installation base	37		Elastic washer 5
15	JAPS-305Y2	Booster pump feeding bowl	38		Inside hexagonal bolt M6 * 20
16	JAPS-110	Booster pump feeding bowl holder	39		Elastic washer 6
17	H30-01-08	Feeding bowl pressing bolt	40	J16943-00	Hydraulic gun shooting reset spring
18	H30-01-38	Large ball valve block ($\phi 26 \times \phi 13$)	41		
19	JAPS-128	Steel ball $\phi 17.5$	42		
20	JAPS-133	Steel ball $\phi 13$	43		
21	JY13867-43	O-ring $\phi 31.5 \times 1.8$	44		
22	A9-04-14	Large sealing part for valve body	45		
23	JAPS-138	O-ring $\phi 27 \times 1.9$	46		

[Visit Equipment Options Direct for parts](#)

JHPK has passed the certification of UKAS quality management system, with the product standard:
Q/DXHPK0001-2012