



BOTTECCHIA[®]

User's Guide

BE01 PITBULL

Display

Electric bicycle intelligent LCD instrument

Specifications

- Power supply: 36V
- Rated current 10mA Corrente di funzionamento
- The maximum working current 30mA
- Off leakage current $<1\mu\text{A}$
- The supply controller working current 50mA
- Use temperature -20°C a 60°C
- Storage temperature -30°C a 70°C

Appearance and Size

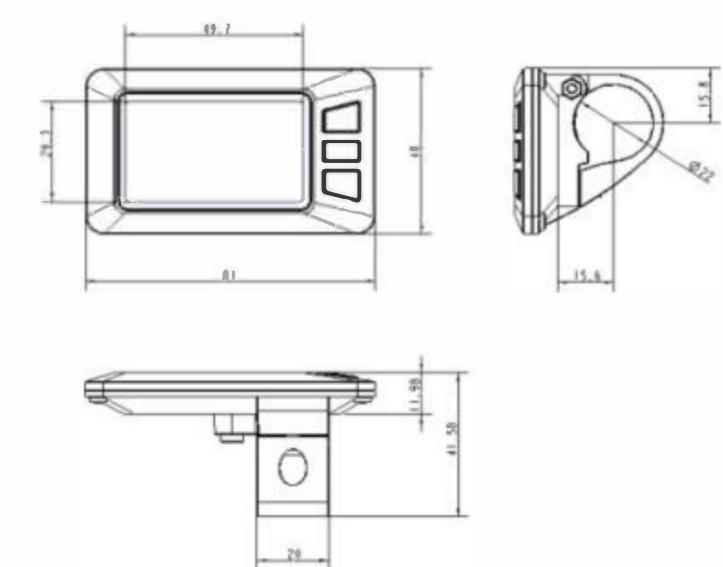

Function Summary

Display can provide a lot of functions to fit the users' need. The indicating contents are as following.

- Speed Indicator
- 6km/h Cruise control
- Headlight On/Off
- Power assist level
- Battery indicator
- Error Code Indicator

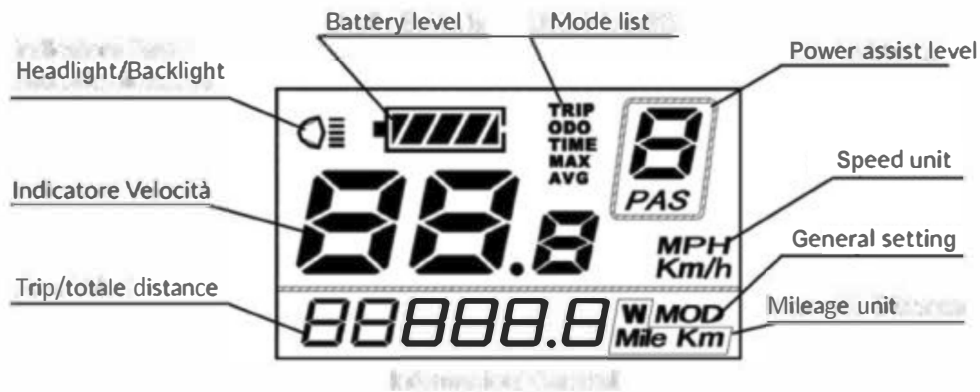

Button Definition

There are three buttons (**M / + / -**) that represent the functions: **MODE / UP / DOWN**.

Power on /off

To turn on /off the e-bike system, hold the M button for 2 seconds.

When parking e-bike for more than 10 minutes, the display shut down automatically.

Display Interface

After starting up the display these are the information displayed:

- Speed
- Total distance
- Battery
- Power assistant level

To change the information shown, press the MODE key. The following parameters will be displayed in this order: Speed (km / h) → Trip distance (km) → Trip distance (ore) → Max speed (km/h) → Medium speed (km/h) → Motor powe (W) → Speed (km/h)

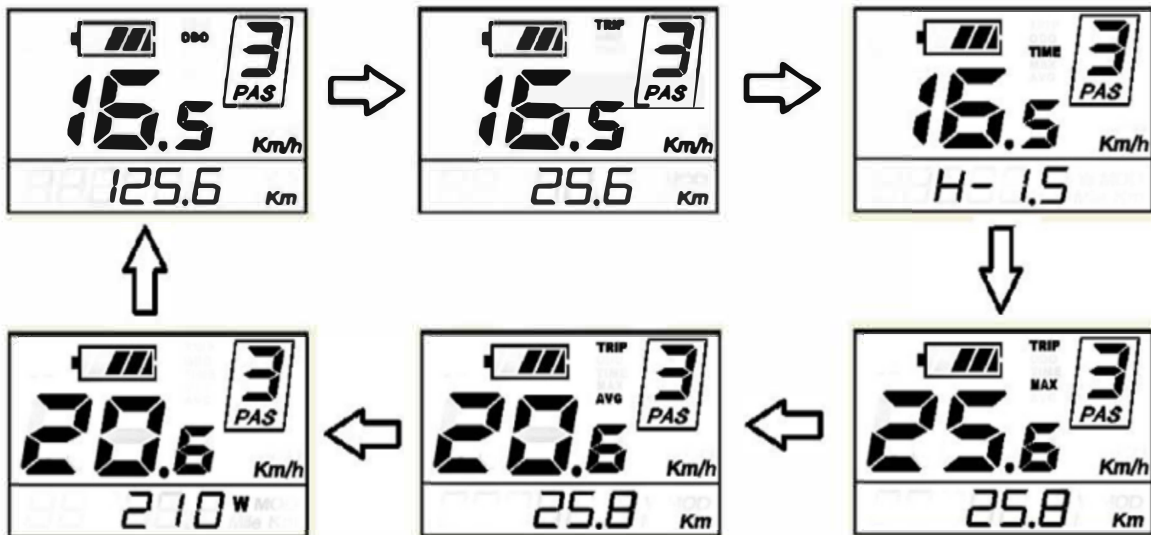

Modalità Walk Assistance (assistenza alla partenza)

To activate the "Walk assistance", hold the button **DOWN**.

The e-bike will go at a uniform speed of 6km / h and show the "P" symbol on the display.
To deactivate the push, release the DOWN button.

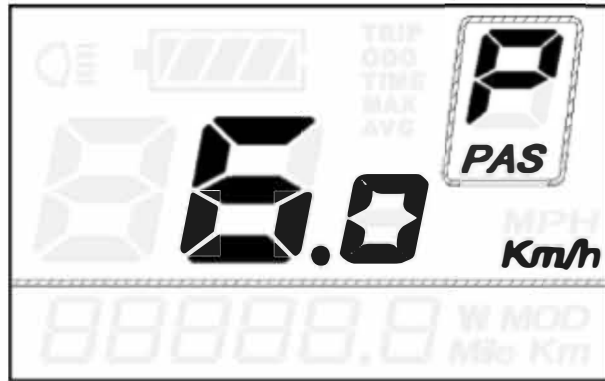

Warnings:

do not use the cruise mode against I when the e-bike has no contact with the ground.

Do not use the pedals while in "cruise versus" mode.

Headlight On /Off

To turn on / off the lights of the e-bike, press the **UP** button for 2 seconds.

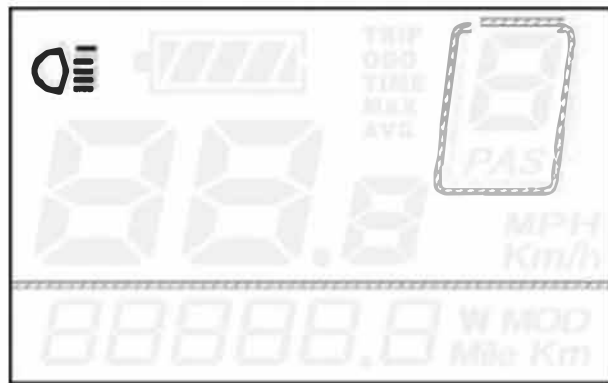

Power assist level Selection

The power assist level indicates the power delivered by the motor.

Default level is "1".

The power range is from "0" (no power) a "5" (maxiumum).

To increase or decrease the power level, press the **UP** / **DOWN** bottons.

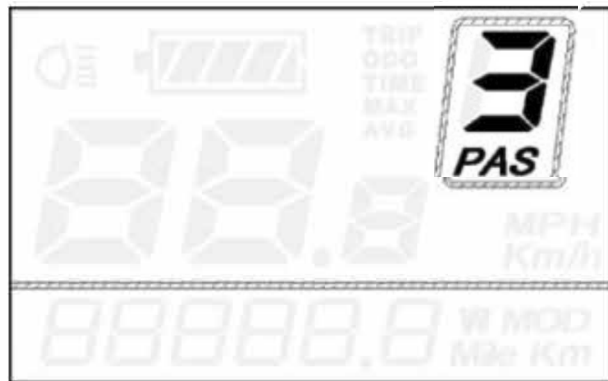

Battery level Indicator

The 5 bars represented in the next image indicate the battery capacity.

When the battery is about to run out, the bars icon will blink.

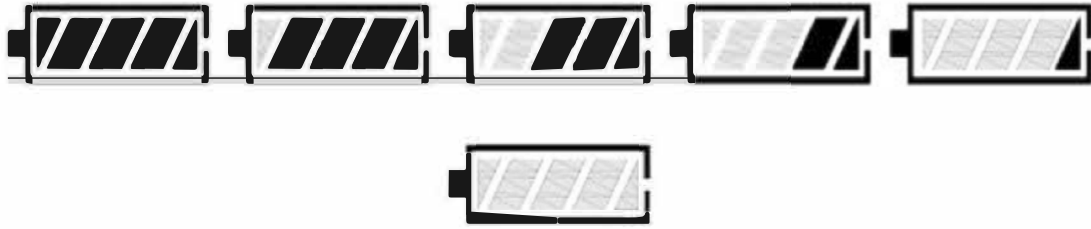

Error Code Indicator

In the event of an error in the electronic system, an error code will be shown on the display. See error code list for details.

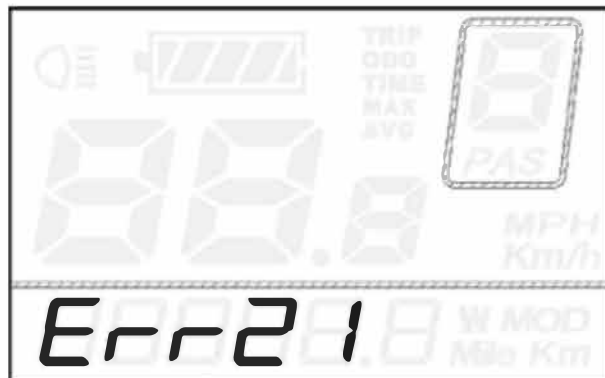

General setting

To access the settings menu, press the **UP** and **DOWN** keys simultaneously for 2 seconds.

Reset trip distance

The **TC** code represents the travel distance reset setting.

To reset the value press the buttons **UP/DOWN** and select **Y** (yes) or **N** (no).

Press the **MODE** key to save and access the backlight menu.

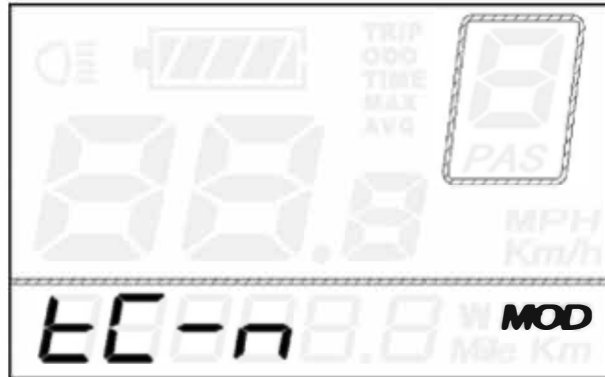

Backlight setting

The **bL** code indicates the Backlight setting.

Level "1" indicates the lowest brightness;
Level "2" the intermediate one;
Level "3" the highest brightness.

The default is "1".

To increase or decrease the brightness, press the **UP** or **DOWN** buttons. Press the **M** button to save and enter the unit change menu.

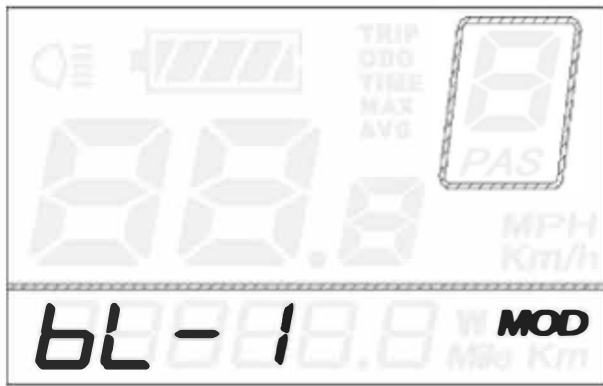

Unit conversation (km / mi)

The **U** code represents the unit change setting: the "1" value indicates miles, "2" the kilometers.

The default value is 2. To convert the unit, press the **UP** or **DOWN** button. Press the **MODE** button to save and access the travel distance reset.

To exit the general settings, press the **MODE** button for 2 seconds.

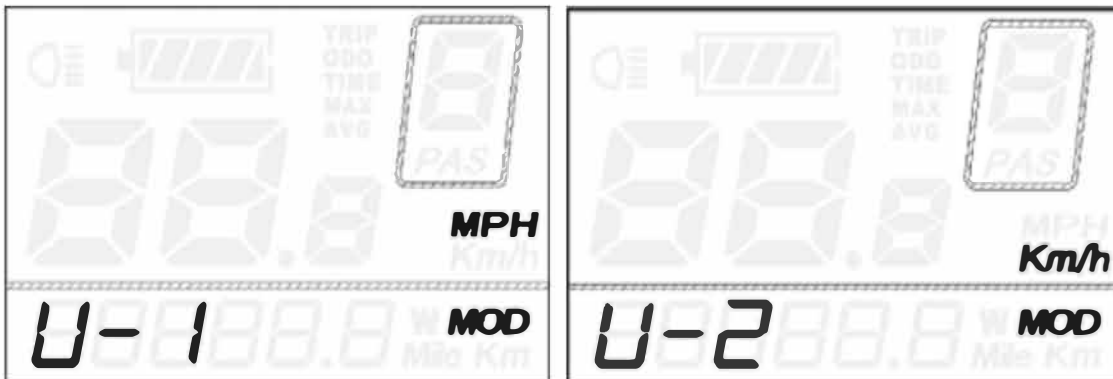

ERROR CODES TAB

ERROR CODE	DEFINITION
21	CURRENT ANOMALY
23	MOTOR ANOMALY
24	SENSOR ANOMALY
25	BRAKE ANOMALY
30	LINKS PROBLEM

NB

In the event that an error is shown on the display, contact the dealer where the bicycle was purchased to verify the problem and solve it.

Battery

Instructions for user

Please read the battery instructions carefully.

- Do not open, disassemble or puncture the battery under any circumstances, it could cause serious damages.
- In the event of a fall, impact or similar events, do not continue to use the battery and bring it to a dealer to check it as soon as possible.
- Use only the special charger provided with the battery.
- Disposal of used batteries must follow local disposal regulations.

Please read carefully the following before use.

- The battery is not supplied fully charged.
- Fully recharge the battery before using it for the first time and before storing it.

- After the first three charging cycles, fully charge the battery. This will give maximum capacity to your battery. If the battery is continuously and completely discharged during use and never fully charged, this will reduce its life.
- Never leave the battery completely empty and recharge it even after a short period of use.
- Do not destroy or disassemble the battery.
- Do not store the battery in a humid place to avoid damage.
- When removing the battery, be sure to follow the rules.
- Do not immerse in water and do not throw it on fire.
- Do not drop the battery.
- When storing the battery for a long time, make sure it is charged for at least half of its capacity, and charge it again at least every two months.
- Do not wrap it with any driver material to prevent it from any damage due to direct contact between metal and battery.
- Store the battery in a dry place.
- The battery should always be kept away from children. Do not allow children to remove the battery or play with it.
- If the battery seems to be in a strange condition, it seems dirty or has a strange smell, do not use it.

Warnings

The battery should not be left in direct sunlight to avoid overheating and to avoid the decrease of its performance and duration.

- Do not touch a battery that leaks liquid. The liquid can cause problem to the skin. If it meets the eyes do not rub but rinse immediately with clean water and go to the hospital.

- Do not put in microwave or other kitchen ovens.
- Keep the battery away from the mobile phones or from the charger if it is hot to the touch, if it leaks liquids or has a strange smell. Dispose of it. Defective batteries can cause overheating, they can catch fire.
- If the battery is completely discharged, charge it as soon as possible. Leaving the battery empty for long periods could damage its capacity.

POWER 522 Wh

RECHARGE TIME 4,5 - 6 h

CHARGE TEMPERATURE 0°~45°C

DISCHARGE TEMPERATURE-20°~60°C

BATTERY RANGE 40 km max

POSITION Tubo sottosella

Battery Charger

The charger is specifically designed to charge lithium-ion batteries. It is equipped with an integrated fuse and overload protection. Keep the battery charger away from children and animals to prevent they damage the cable while playing and to avoid malfunctions.

General warnings

- Children or persons with limited physical and mental abilities, except under the strict control of an adult, should not use the charger.
- Make sure the charger is clean to avoid the risk of electric shock.
- Do not use the charger in places that are humid or full of dust.
- Avoid direct exposure to sunlight.
- Unplug the charger from the power outlet when it is not in use.

- Use only the charger that is supplied with the electric bike.
- Do not cover the charger while it is in use.
- When cleaning the charger, unplug it from the power outlet.
- When the charging time exceeds what indicated on the specifications table, stop charging.
- After charging, disconnect the battery from the charger and the charger from the power outlet.

Battery installation and removing

For a correct installation of the battery, it must be inserted in the appropriate position and locked. Without the contact with the battery the e-bike system does not work. To insert and remove the battery, the safety lock must be unlocked. You can lock and unlock the battery using the supplied key.

Proceed as follows to install the battery:

1. Unlock the battery lock using the key, pressing lightly on the lock.
2. Insert the battery in its seat, located behind the seat tube.
3. Turn the key to the OFF position to lock the battery.
4. To use the bike, set the lock to ON. Now the bike turns on.

To remove the battery from the bike, turn off the bike and follow the previous instructions starting from point 4 to point 1.

LED state of charge

Check the battery charge level by pressing the battery on / off button. The charge level is indicated by leds, which are illuminated differently depending on the charge level.

Charge the battery

You can charge the battery either when it is assembled on the bike or when it is not assembled.

Lithium-ion batteries are not subject to memory so you can recharge the battery at any time even after a short journey. Charge the battery at a temperature between 0 °c and 45 ° c (ideal temperature around 20 ° c).

Read the charger instructions (inside the box) before charging the battery.

Proceed as indicated:

1. Insert the charger cable plug into the battery socket and then the charging socket into the electrical socket.
2. As soon as the cable is plugged into the electrical socket, a red LED lights up.
3. When the charge is complete, the LED will be green.

Charging time depends on various factors. It can vary depending on temperature, age and use and battery capacity. If necessary, you can find information on charging times in the battery technical data. When the battery is fully charged, the charging process stops automatically. Remove the socket from the battery and the electrical outlet.

Use the own battery charger of the battery.

Be sure to use the correct main voltage. The correct main voltage required is indicated on the charge. It must respect the voltage of the current source. The 230V chargers can also operate at 220V.

Warnings

- Do not touch the socket with wet hands to avoid shock.
- Before using the charger, the cable and the socket, check that they are intact. If there are any damage, do not use the charge to avoid electric shocks.
- Charge the battery in well-ventilated areas.
- Do not cover the battery and charger during charging.
- Charge only on dry and non-flammable surfaces.

IMPORTANT:

The battery must be fully charged at least every 2 months to avoid damage or destruction of the cells. If the charging time exceeds the usual charging time (see table), the battery may be damaged. In this case, stop charging immediately and bring both the battery and the charger to a dealer for a check.

Store the battery

If you do not use your e-bike for a long period, remove the battery, charge it (60-80%) and store it in a dry place.

Warnings

- Check the charge level every 2 months and recharge if necessary.
- Store the battery in a place between -10 ° C and 35 ° C. Be aware that temperatures around 45 ° C can be easily reached near the radiators and inside the vehicles left in the sun.

- Avoid storing the battery in direct sunlight.
- To prevent the complete discharging, the battery will go into "sleep" mode after a certain period.
- Do not expose the battery to temperatures lower than those allowed -10 ° c.
- If you notice that the battery becomes hot during use, during charging or during storage or if it gives off a strong odor, changes its appearance or any other anomaly, do not continue to use the battery but take it to a dealer for inspection before using it again.

Battery wear

The battery has a life of about 700-800 recharge cycles. As battery usage increases, battery capacity slowly decreases.

This also reduces the travel range of your e-bike and does not constitute a defect.

If the distance is still sufficient according to your needs, you can continue to use the battery.

Battery life depends on various factors:

- Number of recharges (about 700/800 charge cycles).
- The age of the battery
- Storage and use conditions.

Obviously, the battery deteriorates and loses capacity even if it is not used. The life of

your battery may be affected by the following precautions:

- Charge the battery after each run even if it is a short journey. Lithium ion batteries are not subject to memory effects.
- Avoid riding for long distances with high gears on high slopes with assistance at the maximum level.

Disposal

If you replace parts of your e-bike, please take note of the local waste disposal regulations. Used batteries and accumulators do not have to be disposed with normal household waste. Every consumer is required by law to dispose of used batteries at specific collection points at a recycling center, a battery trading company, a specialist retailer or manufacturer.

Batteries containing dangerous substances are marked with a symbol consisting of a waste bin and the chemical symbol (Cd, Hg or Pb) of heavy materials, which are responsible for their classification as pollutant. For more information, please contact your local waste disposal service or your municipal administration. Exhausted batteries, accumulators with LEDs, NiMH (nickel metal hydride) or lithium ion technology are to be considered dangerous goods. Lithium-ion batteries must be insulated in each pole with insulating tape to prevent short circuits and potential dangerous reactions. During the transport or the transfer of the exhausted batteries to the waste disposal facilities, the ADR regulations (regulation for the transport of dangerous goods) have to be applied. In compliance with the European Directive 2006/66 / EC, defective or used batteries must not be used, and according to the European directives 2002/96 / EC, electrical equipment that can no longer be used must be collected separately and recycled in an environmentally friendly way respecting the environment. The drive unit, the battery, the display, the control element, the accessories and the packaging must be recycled in an environmentally friendly manner. Do not dispose electronic drive components with household waste.