

# BENEFITS OF AN INTEGRATED CAPILLARY LC COLUMN SYSTEM

Hans-Jürgen Wirth<sup>1</sup>, Jana Habsuda<sup>1</sup>, Peter Dawes<sup>1</sup>, Ern Dawes<sup>1</sup> and Richard Henry<sup>2</sup>  
<sup>1</sup>SGE International Pty. Ltd. 7 Argent Place, Ringwood 3134, Australia. <sup>2</sup>SGE Consultant

## INTRODUCTION

With the desire to analyse trace components, such as marker proteins or drug metabolites in very complex biological samples, comes the need for *optimised micro/nano liquid LC systems*. A crucial factor in the optimisation of a chromatographic system is the reduction of band broadening. In order to reduce band broadening, the amount of extra-column volume has to be minimised. Thus, all components of the ProteCol™ capillary LC system, the column, the tubing, filtering connectors and unions were optimised to provide the best possible conditions for a good separation.

## MAIN ADVANTAGES OF SMALL BORE LC

### • Increased sensitivity:

Reducing the internal diameter (ID) of a column by a factor of two increases the sensitivity by a factor of four. Using a 300µm ID column instead of a 4.6mm ID column increases sensitivity more than 200 times

### • Reduced sample size:

To gain the same sensitivity more than 200 times less sample is needed when using a 300µm ID column compared to a 4.6mm ID column

### • Low flow rates:

Allow direct injection into a mass spectrometer

### • Reduced solvent consumption:

If a 4.6mm ID column is run at 1mL/min the equivalent flowrate for a 300µm ID will be about 4.3µL/min

## MAIN FEATURES OF INTEGRATED ProteCol™ CAPILLARY LC COLUMN SYSTEM

The range of products for capillary LC (developed by SGE) is designed to keep the extra column void volumes at a minimum. The integrated column design combines the *column body, frits and connection tubing in a single unit*, which can be directly attached to the injector and detector, thus reducing the number of connections (**Figure 1**). To allow the perfect chromatography, an integrated column design is complemented by *in-line filters, guard columns and trap-columns* for sample concentration.

Tubing connectors are commonly a source of void volume either inherited by their design or introduced by operator error. The connection tubing (in SGE columns) is made of a *fused silica lined PEEK™ tubing, PEEKsil™*. The tubing *ends are precision square cut* and then *polished to allow virtually dead-volume-free butt connections* (**Figure 2**).



PEEKsil™ tubing showing the ground and square cut end enabling a zero dead volume connection.

**Figure 2.**

Conventional PEEK™ tubing as supplied showing a rough cut end resulting in dead volume and a loss in chromatographic efficiency.

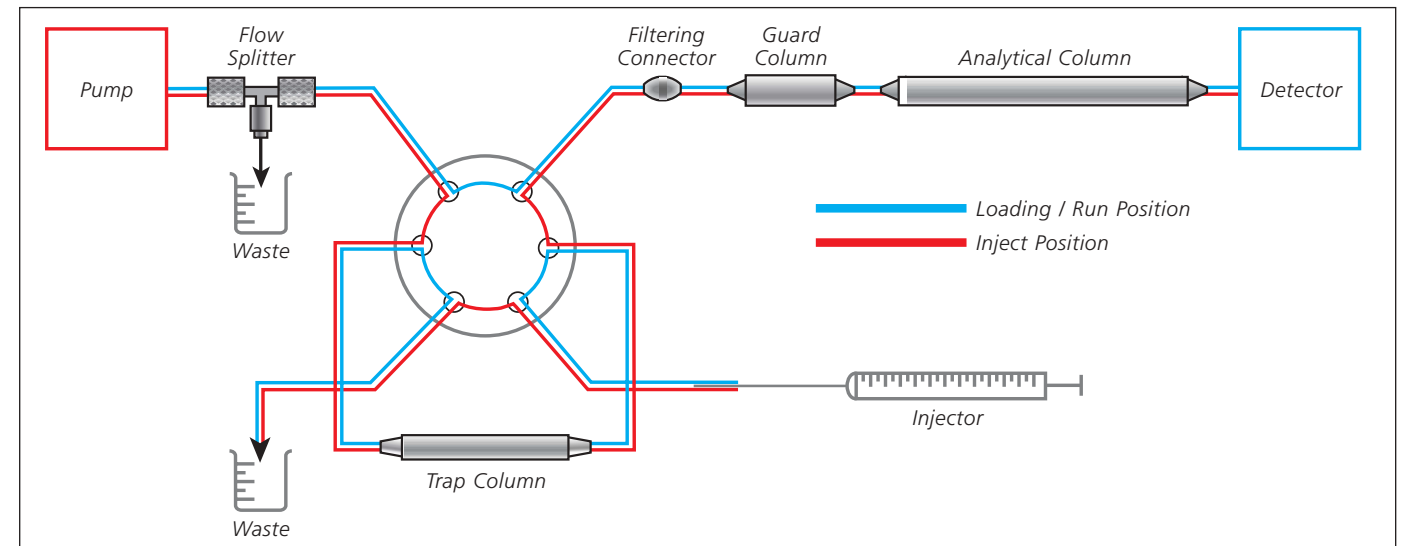

**Figure 1.** Integrated ProteCol™ capillary LC column system.

## BENEFITS OF PEEKsil™

PEEKsil™ (fused silica tubing coated with PEEK™) tubing has all the benefits of fused silica such as inertness and smooth uniform surface characteristics but is far more rugged due to the PEEK coating. Comparison of the sample distribution when pumped through 1000mm of PEEK, PEEKsil and stainless steel tubing (of 100µm ID each) is shown in **Figure 3**.

## CONCLUSIONS

To take full advantage of the benefits of capillary LC, each part of the flowpath has to be optimised in order to minimise sample spreading. The ProteCol™ range of columns and accessories provide a complete system to adjust LC to the needs of capillary LC. Individual components can be easily reconfigured to obtain an integrated solution for a vast range of applications without compromising in performance.

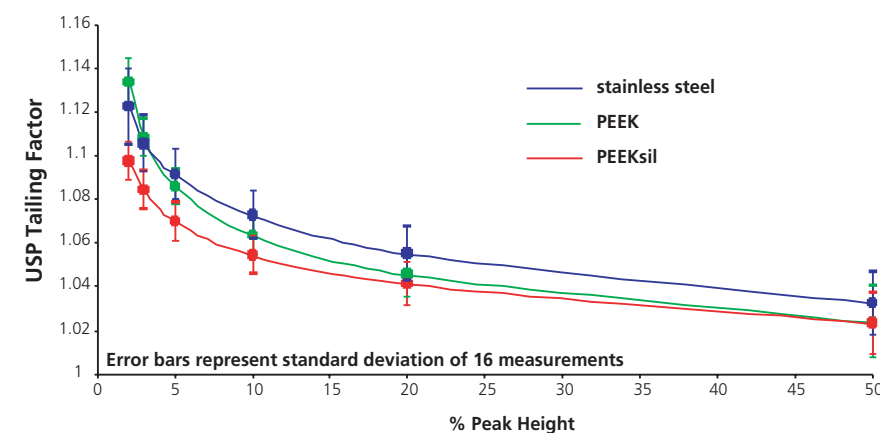

**Figure 3.** Comparison between PEEK™, PEEKsil™ and stainless steel tubing.



**SGE Europe Ltd**  
 1 Potters Lane, Kiln Farm, Milton Keynes, MK11 3LA, United Kingdom  
 Tel: +44 (0) 1908 568844 Fax: +44 (0) 1908 566790  
 Email: uk@sge.com Web: www.sge.com

**SGE (Deutschland) GmbH**  
 Dolivostr.12,D-64293 Darmstadt, Germany  
 Tel: +49 6151 860486 Fax: +49 6151 860489  
 Email: germany@sge.com

**SGE (France) SARL**  
 12, Avenue du Québec, BP 98 Villebon  
 91943 Courtaboeuf Cedex, France  
 Tel: +33 1 69 29 80 90 Fax: +33 1 69 29 09 25  
 Email: france@sge.com