



**MULTIDIMENSIONAL  
CAPILLARY GC SYSTEM FOR  
AGILENT TECHNOLOGIES  
6890 GC**

**Installation and Operating Instructions**

SGE International Pty. Ltd.  
7 Argent Place,  
Ringwood, 3134  
Australia

Publication No. MN-0279-E  
Rev:07 1/06



# CONTENTS

<b>1.0 WARRANTY</b> .....	<b>2</b>
1.1 Declaration of Conformity .....	
<b>2.0 INTRODUCTION</b> .....	<b>3</b>
<b>3.0 SPECIFICATIONS</b> .....	<b>4</b>
3.1 6890 GC Requirements .....	4
3.2 Gas Supplies .....	4
3.3 Packing List .....	4
3.4 Reorder List .....	5
3.5 Safety .....	6
<b>4.0 INSTALLATION</b> .....	<b>7</b>
4.1 General .....	7
4.2 Hardware Components .....	7
4.3 Balancing the Analytical Column and the Fused Silica Restrictor .....	16
4.4 Optimizing the Mid-Point Restrictor .....	16
<b>5.0 OPERATION</b> .....	<b>17</b>
5.1 General .....	17
5.2 Software Configuration .....	17
5.3 Split-Splitless Mode Injections .....	17
5.4 Backflush Operation .....	18
5.5 Variable Splitter Operation .....	19
5.6 Heart-Cut Operation .....	20
5.7 Cryogenic Cold Trap Operation .....	21

## **1.0 WARRANTY.**

This MDS system is guaranteed against faults in materials or workmanship for a period of twelve months from the date of invoice.

This warranty implies free repair and or replacement of defective goods only, upon proper written proof and, where authorised, return of the defective product.

THIS UNIT HAS BEEN DESIGNED TO FULFIL THE PURPOSE OF MULTIDIMENSIONAL COLUMN SWITCHING AND THIS WARRANTY IS VOID IF THE INSTRUMENT IS USED FOR ANY UNRELATED PURPOSES. SGE RESERVES THE RIGHT TO REFUSE FREE SERVICE UNDER WARRANTY ON ANY UNIT WHICH HAS BEEN ABUSED OR TAMPERED WITH IN ANY WAY.

No other warranty or representation is expressed or implied by SGE for its products with respect to merchantability and fitness for any particular use or purpose, or any other matter. SGE shall not under any circumstances, be liable for any incidental, consequential, or compensatory damages arising from use of or in conjunction with its products. The maximum liability for breach of warranty shall be the invoice price of the said products.

The MDS HP6890 does not have any user serviceable parts. All servicing should only be performed by qualified service personnel.

## **2.0 INTRODUCTION.**

The SGE Multidimensional Chromatography System provides an inexpensive means of upgrading dual amplifier and detector Gas Chromatographs for multidimensional chromatography.

With the MDS HP6890, two gas chromatography columns are used in series to create two separation dimensions giving enhanced resolution capacity. Where existing capillary columns cannot provide the necessary resolution of components present in a sample group, that group may be switched to another capillary column more suited to the separation. This avoids the use of very long columns and complex temperature profiles. Apart from the ability to resolve peaks that were previously unresolvable, shorter analysis times and extended column life can be expected.

All switching on the MDS HP6890 is controlled by the external events and EPC module of the HP6890. Programming of the function can be via the HP6890 keypad or HP Chemstation software.

## 3.0 SPECIFICATIONS.

### 3.1 HP6890 GC Requirements

The HP6890 GC requires the following options for successful installation and operation of the multidimensional kit.

- 1 x EPC Injection Port
- 2 x atmospheric detectors (eg. FID, ECD, NPD)
- 1 x Auxillary 3 channel EPC (HP Part No. G1570A)

### 3.2 Gas Supplies

The MDS HP6890 requires a supply of high purity carrier gas, a suitable make up gas and a suitable valve actuation gas. If the cryogenic trap is to be used, a bottle of technical grade CO<sub>2</sub> with a dip tube is also required.

### 3.3 Packing List

#### Capillary to Capillary System (Part No. 0933406)

Description	Quantity
MPPVT-MDS Valve	1
MOVP-CO <sub>2</sub> Valve	1
CTS-LCO <sub>2</sub> Cold Trap (fitted to bracket)	1
MRC/0.2 Restrictor (fitted to bracket)	1
MPPVT Valve Seat (pkt of 5)	1
PTFE Seal, MOVPT Valve (pkt of 2)	1
BS001 "O" Ring	1
VSR/16 Sealing Ring (pkt of 10)	2
2VSD/320 I.D. Fused Silica Tubing	1
1/4" x 5/16" AF Spanner	1
1/16" Allen Key	1
Self Tap Screws 8 x 1/2"	6
Mounting Bracket	1
GFF/8 Graphite Ferrules (pkt of 5)	1
6BA Allen Key1	
MRC/0.3 Restrictor	1
2VSD - 150 I.D., 320 O.D.	1
2VSD - 110 I.D., 320 O.D.	1
GVF/004 Vespel Ferrule (pkt of 5)	1
GVF2/004 Ferrule (pkt of 5)	1
GVF2/004/005 Ferrule (pkt of 5)	1
GVF/005 (pkt of 5)	1
GVF/008 (pkt of 5)	1
1/16" x 0.8mm I.D. x 10 metre Stainless Steel Tubing	1
Instructions	1
Union SSMFU 8-16	2
VFF/0.2-0.35 (pkt of 5)	1
VSR/8 Sealing Ring (pkt of 10)	1
Bracket Drivers Assembly	1

### 3.4 Reorder List

<b>Part Number</b>	<b>Description</b>	<b>Quantity</b>
0933430	MRC/0.2 Restrictor Kit	1
0933431	MRC/0.3 Restrictor Kit	1
093346	CTS-LCO2 Cold Trap	1
0933438	Mounting Bracket Cap to Cap	1
0624459	2VSD 110 I.D. 320 O.D.	1
0624465	2VSD 150 I.D. 320 O.D.	1
0624469	2VSMD 220 I.D. 320 O.D.	1
0624477	2VSD 420 I.D. 550 O.D.	1
0932163	Skirt Seal, MOVPT Valve	1
040103	BS001 "O" Ring Seal	1
123687	PTFE Seal, MPPVT Valve	1
0933435	MPPVT Valve Seat	1
0933424	50µm filter, Cold trap	1
072654	GVF/005 Ferrule (pkt of 10)	1
072663	GVF/004 Ferrule (pkt of 10)	1
072662	GVF2/004 Ferrule (pkt of 10)	1
0726642	GVF2/004/005 Ferrule (pkt of 10)	1
072655	GVF/008 Ferrule (pk of 10)	1
072626	OGF/008 Ferrule (pkt of 10)	1
072601	GFF/4 Ferrule (pkt of 10)	1
072602	GFF/8 Ferrule (pkt of 10)	1
072653	VSR/16 Sealing Ring (pkt of 10)	1
101230	SSU-4/16 Union	1
101290	SSU-8/16 Union	1
072652	VSR/8 Sealing Ring (pkt of 10)	1
101210	SSMFU-8/16 Union	1
0726558	VFF step ferrule MDS (pkt of 2)	1
062416	1/16" x 0.8mm x 10m SS Tubing	1

### 3.5 Safety



**Warning** This warning symbol means danger. You are in a situation that could cause bodily injury. Before you work on any equipment, be aware of the hazards involved with electrical circuitry and be familiar with standard practices for preventing accidents.

**Attention** Ce symbole d'avertissement indique un danger. Vous vous trouvez dans une situation pouvant causer des blessures ou des dommages corporels. Avant de travailler sur un équipement, soyez conscient des dangers posés par les circuits électriques et familiarisez-vous avec les procédures couramment utilisées pour éviter les accidents.

**Avvertenza** Questo simbolo di avvertenza indica un pericolo. La situazione potrebbe causare infortuni alle persone. Prima di lavorare su qualsiasi apparecchiatura, occorre conoscere i pericoli relativi ai circuiti elettrici ed essere al corrente delle pratiche standard per la prevenzione di incidenti.

**Warnung** Dieses Warnsymbol bedeutet Gefahr. Sie befinden sich in einer Situation, die zu einer Körperverletzung führen könnte. Bevor Sie mit der Arbeit an irgendeinem Gerät beginnen, seien Sie sich der mit elektrischen Stromkreisen verbundenen Gefahren und der Standardpraktiken zur Vermeidung von Unfällen bewußt.

**¡Atención!** Este símbolo de aviso significa peligro. Existe riesgo para su integridad física. Antes de manipular cualquier equipo, considerar los riesgos que entraña la corriente eléctrica y familiarizarse con los procedimientos estándar de prevención de accidentes.

## 4.0 INSTALLATION.

### 4.1 General

These instructions apply for both capillary to capillary mid-point restrictors i.e. the MRC/0.2 for 0.22 / 0.25mm ID analytical columns and the MRC/0.3 for 0.32mm ID analytical columns.

### 4.2 Hardware Components

4.2.1. Remove a section of the exterior oven wall plate and insulation on the front left side of the HP6890 GC (Refer Diagram 1).

#### Diagram 1 - Valve Mounting Location

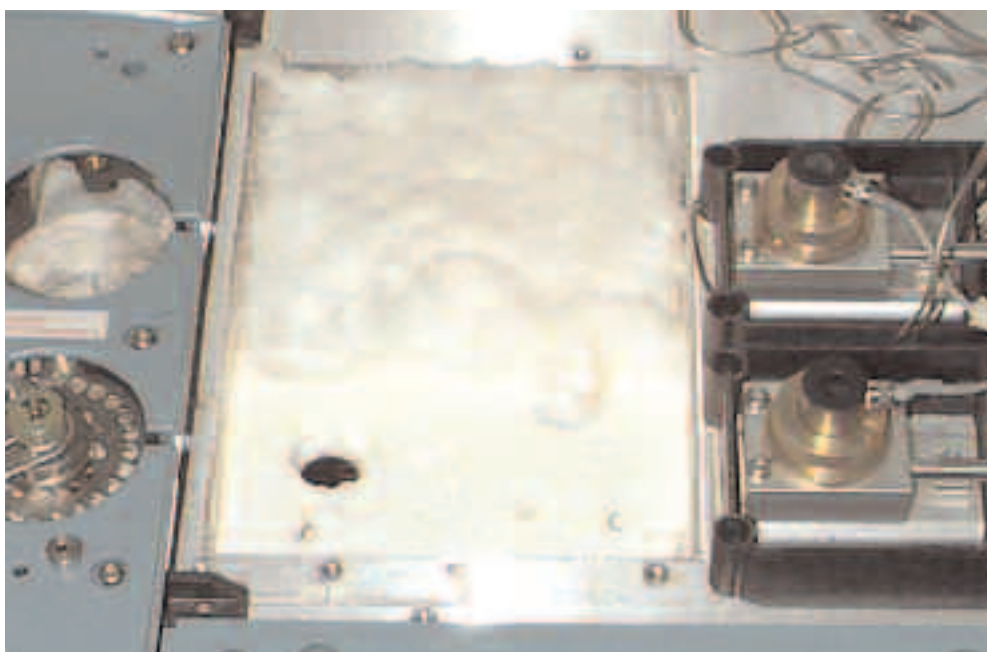



4.2.2. Install the mid point mounting bracket (1) inside the HP6890 oven as illustrated in Diagram 2, utilising the existing hole approximately 8cm right from the centre of the front injection inlet. A Toggle screw has been provided to secure it in place.

**Diagram 2 - Capillary Bracket Location**

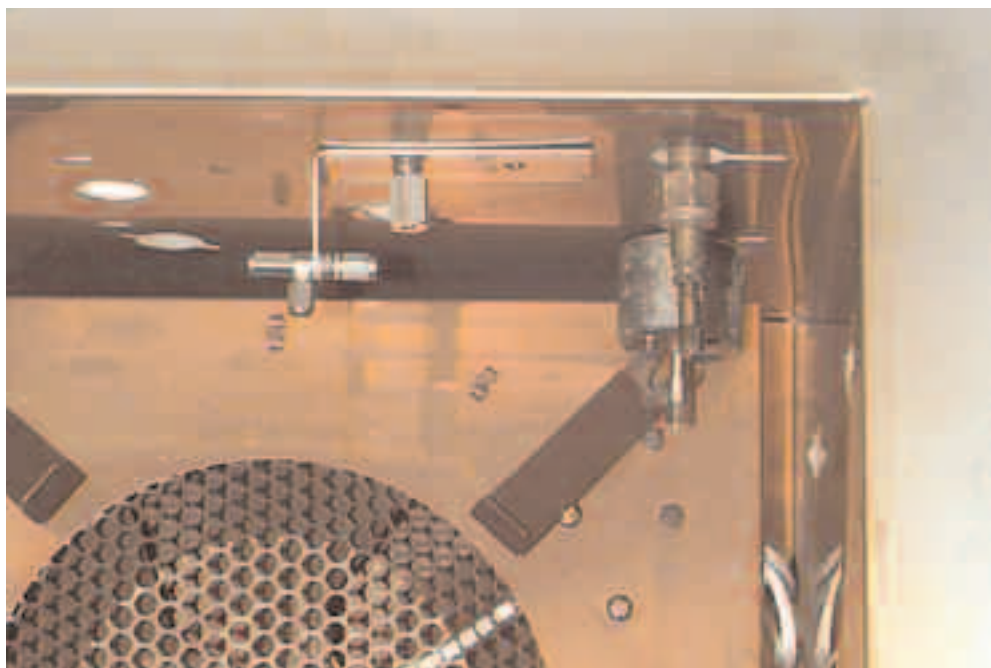

4.2.3. The mounting bracket (1) is supplied with an MRC/0.2 mid-point restrictor (3) fitted (Refer Diagram 3)

**Diagram 3 - Capillary Bracket Assembly**

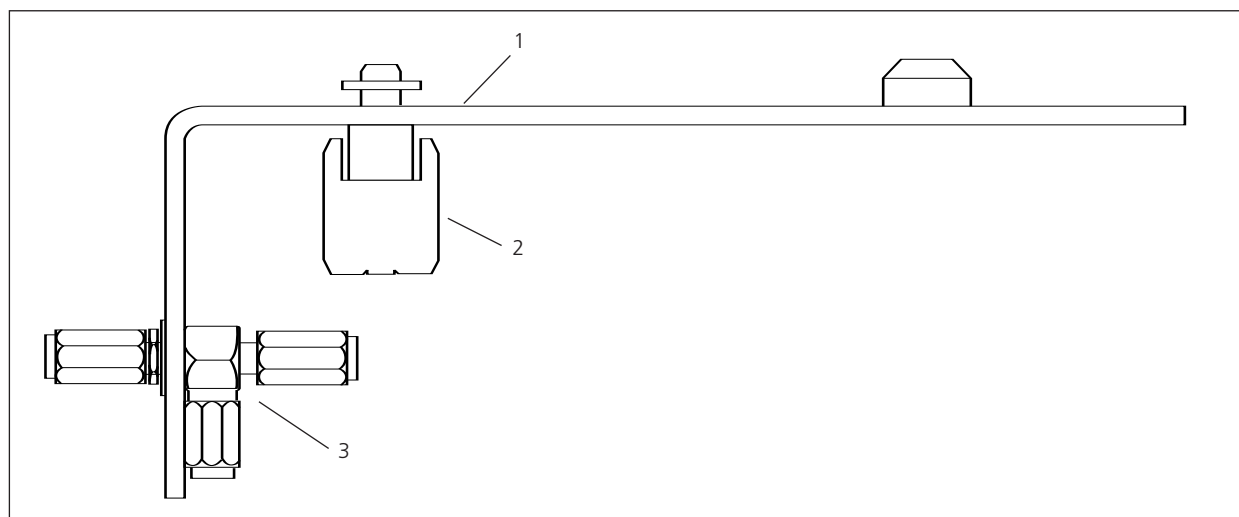

4.2.4. If the cold trap is to be used, the appropriate cryogenic valve needs to be attached to the cold trap tee. This is held in place by the 5cm 1/8 inch threaded bracket support which screws into an existing thread (Refer Diagram 4). If liquid N2 is to be used as the cryogenic coolant, the liquid N2 valve and tee (not supplied) should be fitted in place of the CO2 cold trap system. (SGE P/N 0933450)

**Diagram 4 - Cryogenic Valve Installation**

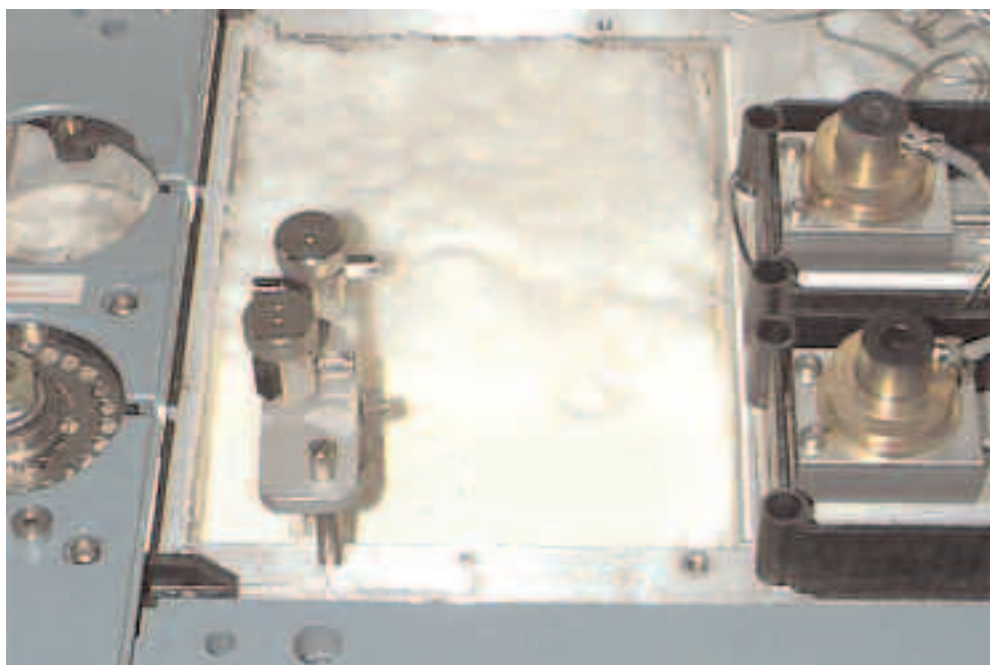

4.2.5. The mid point restrictor (3) may be replaced with another of a different ID, if an analytical column of different ID is to be used.

The type of capillary to capillary restrictor can be identified by the number stamped on the body of the restrictor tee.

<b>Valve Body Mark</b>	<b>Analytical Column</b>
0.4	0.22 / 0.25mm ID
0.5	0.32mm ID

4.2.6. The pneumatic valve (MPPVT-MDS) can be inserted through an existing oven wall hole located 3cm to the rear of the inserted cold trap tee (Refer Diagrams 5, 6 and 7) and held in place by the supplied 5cm 1/8 inch threaded bracket support (7), located in an existing threaded hole. Alternatively, a base plate (14) can be used to secure the valve to the oven wall with the screws provided.

**Diagram 5 - MPPVT-MDS Valve Location**

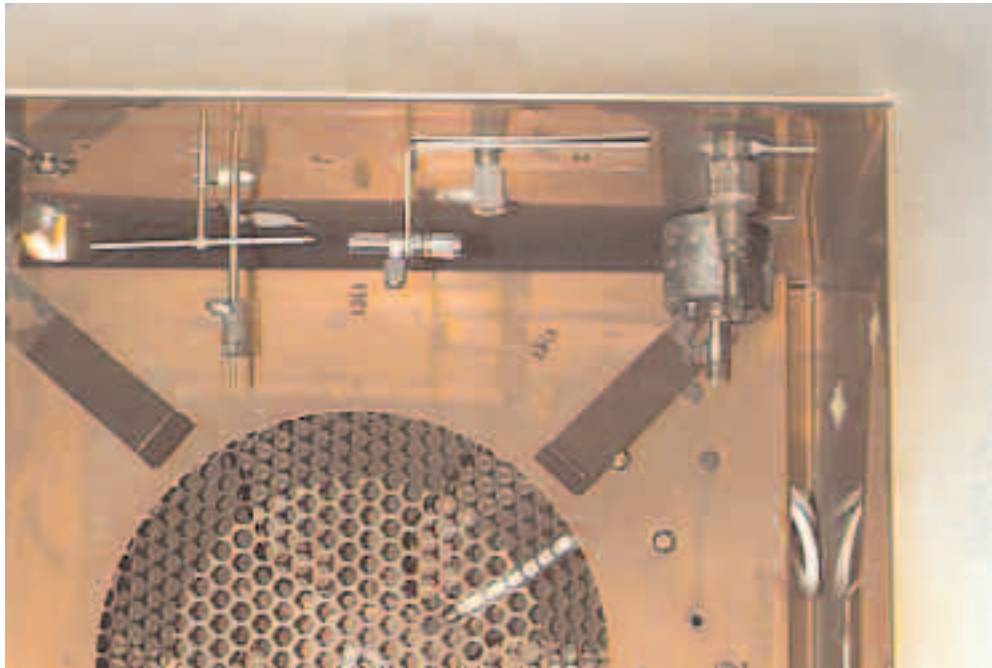

**Diagram 6 - MPPVT-MDS Valve Assembly**

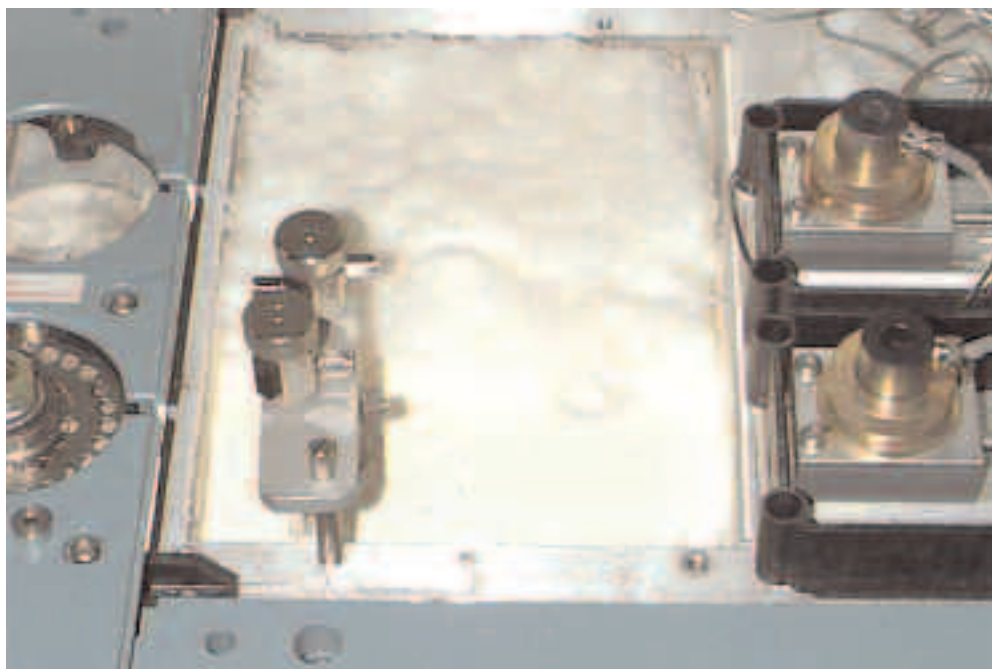

4.2.7. Disassemble the valve by unscrewing the valve stem (8). Pass the lower assembly of the valve through the hole in the oven wall.

4.2.8. Positioning of the valve and mounting bracket can be accomplished by loosening the grub screw (9).

4.2.9. Reattach the valve stem to the pneumatic head assembly.

#### 4.2.10. System Connections

In making the various stainless steel tubing connections into the GC oven, it is important that neat, space conserving runs be utilised. The gas connections are mostly made using 1/16 inch stainless steel tubing and VSR/16 sealing rings. Diagram 8 illustrates all required plumbing modifications.

**Diagram 7 - MPPVT MDS Valve**

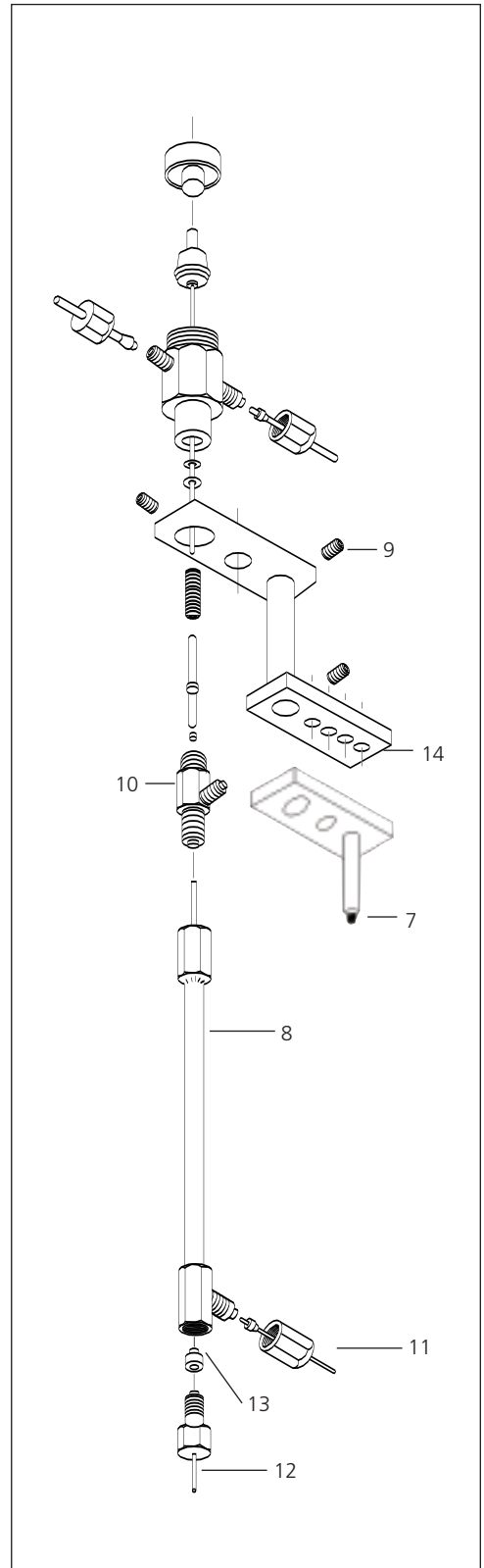
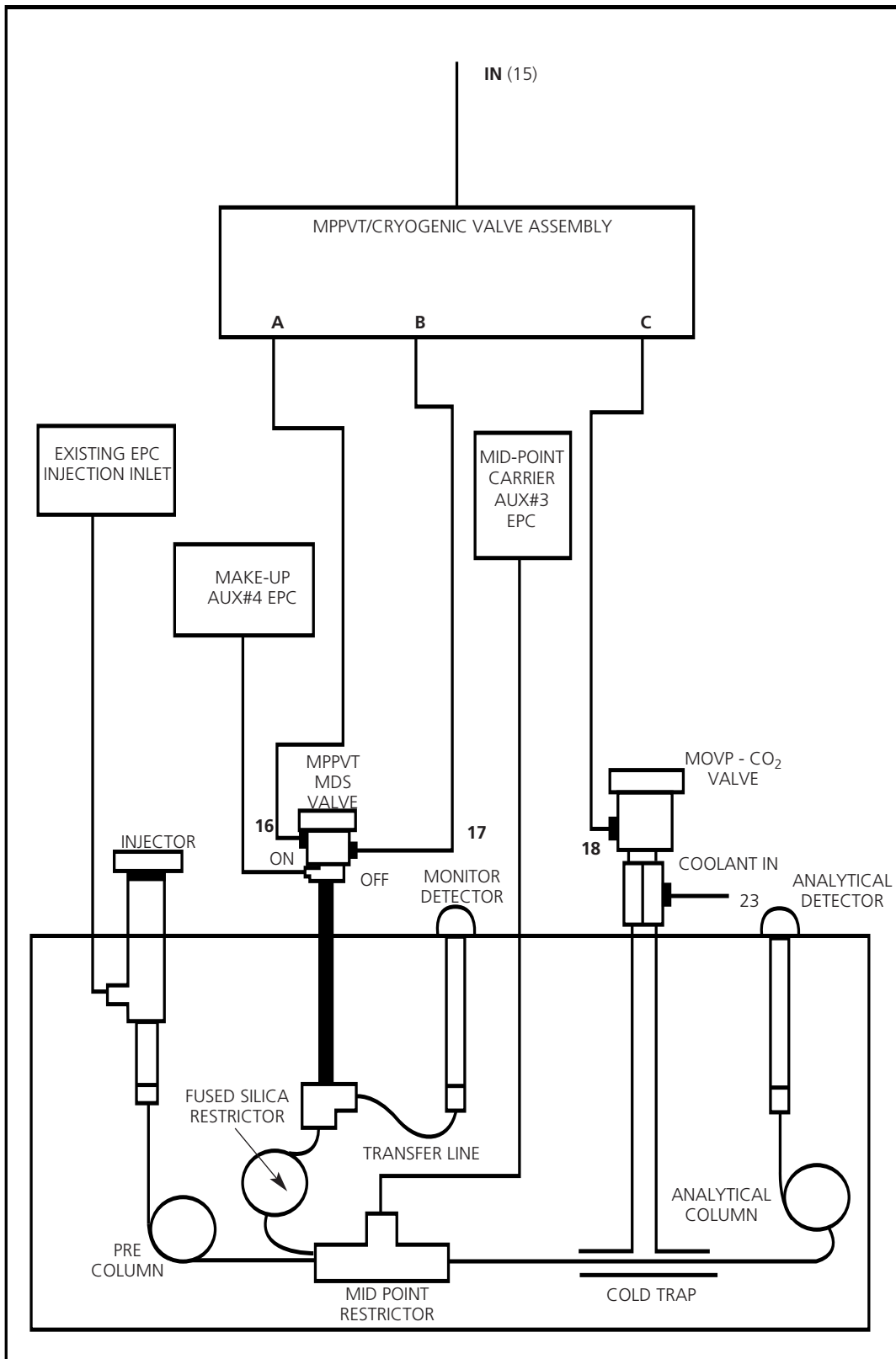

Diagram 8 - Capillary MDS HP-6890 System



4.2.11. Install the auxiliary 3 channel EPC module into the 6890 GC at this time (Refer Agilent Technologies (HP) Instructions entitled "Installation Guide: Auxiliary Pressure Control Manifold"). Ensure that Auxiliary ports 3 and 4 have a red coded restrictor installed, and are installed with the appropriate gas supplies. Auxiliary 5 is not used in this system.

Auxiliary 3 - H<sub>e</sub> or H<sub>2</sub> carrier gas supply

Auxiliary 4 - Make up gas supply

4.2.12. Connect auxiliary 3 to the mid point restrictor via the SSMF 8-16 union using a VSR 16 sealing ring and a GFF 8-8 graphite ferrule. The incorporation of this reducing union eliminates the cutting of the original auxiliary EPC lines.

4.2.13. Connect auxiliary 4 to the make up inlet (10) of the MPPVT MDS valve also using a SSMFU 8-16 union, VSR 16 sealing ring and GFF 8-8 graphite ferrule (Refer Diagram 7).

4.2.14. Install the MPPVT / Cryogenic switching valve assembly into the rear cavity of the front detector EPC location as shown in Diagram 9, and lock into place with the hex screw. The gas supply lines to the front detector EPC module can be moved to the left to ensure there is sufficient space for the valve assembly. Install the 1/8 inch air actuation gas supply (15) using a VSR 8 sealing ring, and the following 1/16 inch actuation gas supplies to the MPPVT and Cryogenic switching valves (Refer to Diagrams 8 and 10) with VSR 16 sealing rings.

<b>Switching valve assembly output</b>		<b>Location</b>
16	(A)	MPPVT MDS Valve - On
17	(B)	MPPVT MDS Valve - Off
18	(C)	MOVP - CO <sub>2</sub> Valve

4.2.15. Plug the MPPVT / Cryogenic switching valve assembly lead into the external events port located at the rear of the HP6890 GC.

4.2.16. Connect a 1/16 inch line from a liquid CO<sub>2</sub> supply to the inlet of the cryogenic valve (23)

Diagram 9 - MPPVT / Cryogenic switching valve assembly

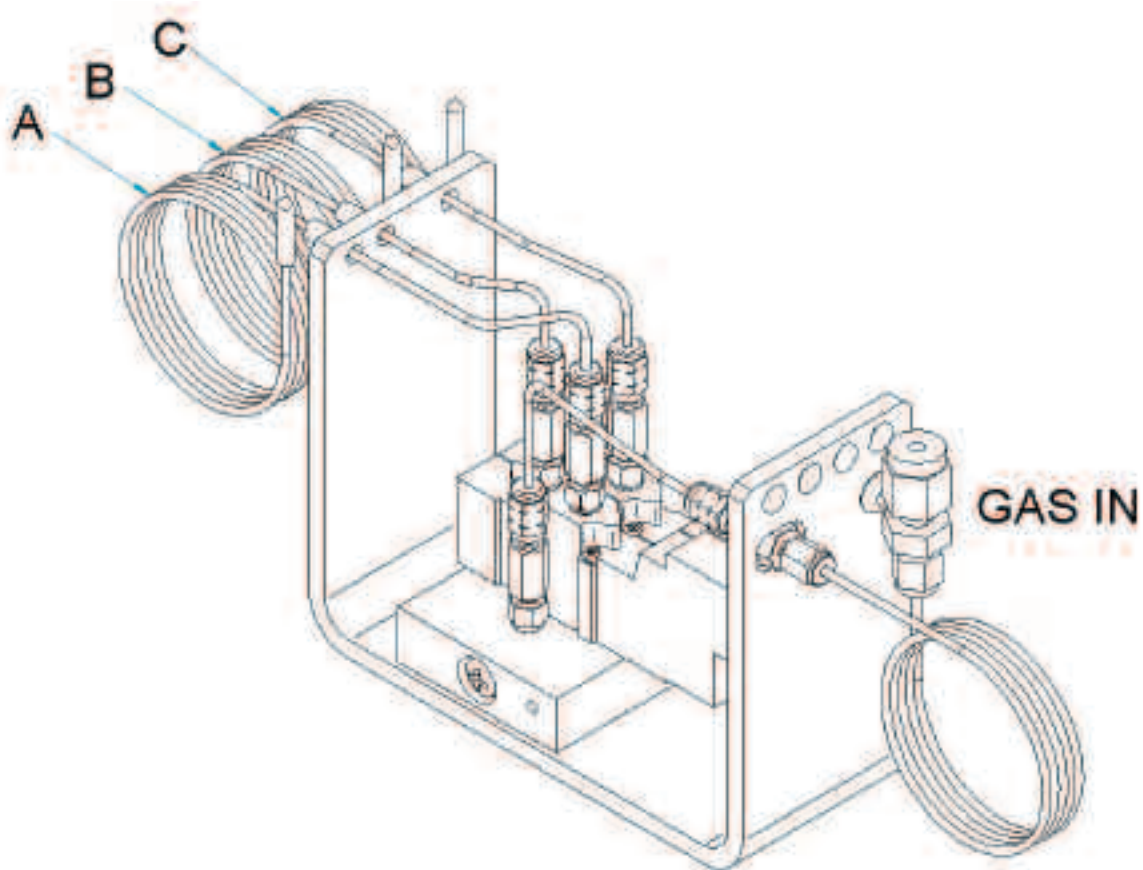
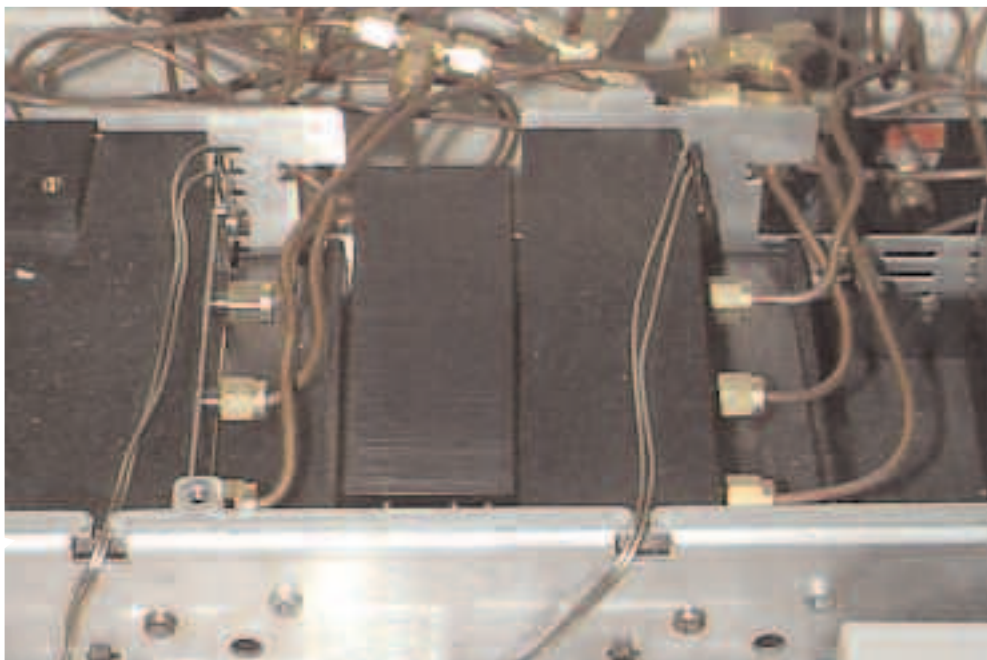



### Diagram 10 - Schematic of Valve assembly

4.2.17. Connect a short length of the wide bore fused silica (2VSD/420 ID) from the smaller 0.8 ID side arm of the MPPVT-MDS valve (11) to the monitor detector. Ensure the silica is inserted all the way into the valve side arm.

4.2.18. Connect the desired pre-column to the injector

4.2.19. Select the appropriate fused silica restrictor and two hole ferrule to make a connection with the pre-column to the inlet side of the mid-point restrictor.

Pre-Column	Ferrule	Fused Silica Restrictor
0.22 / 0.25 mm ID	GVF2/004	2VSD 110 ID 320 OD
0.32 mm ID	GVF2/004/005	2VSD 150 ID 320 OD

For the GVF2/004/005 two hole ferrule, one hole is smaller than the other. The smaller hole is intended for the narrow bore fused silica restrictor tubing.

4.2.20. Insert the ends of the pre-column (19) and restriction tubing (20) through the nut (21) and through the two hole graphitised vespel ferrule (22) (Refer Diagram 11).

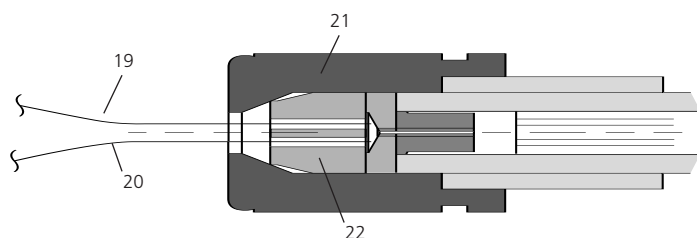

### Diagram 11 - Two Hole Ferrule Connection

4.2.21. Check the front of the tubes to ensure that they are reasonably flat across their diameters. If they are not, new breaks should be made to ensure that both tubes have clean square ends.

4.2.22. Place a small piece of tape across both tubes behind the connecting nut to hold this alignment until the connecting nut can be tightened.

4.2.23. Hold the tube ends in place while the nut and ferrule are moved up to the mid-point restrictor and tightened. Slight forward pressure is maintained on the two tubes to hold them in position until the ferrule has locked them in place. Tighten the nut until the connection is found to be leak free.

4.2.24. Insert the analytical column into the outlet end of the mid-point restrictor (refer to diagram 12) after passing it through the cold trap tee if applicable. Insert the column into the mid-point restrictor until it contacts at the inlet end. The column is then withdrawn approximately 1mm inside the extended nut and locked into place with a GVF/005 ferrule for 0.32mm ID analytical columns, or a GVF/004 ferrule for 0.22 / 0.25mm ID analytical columns.

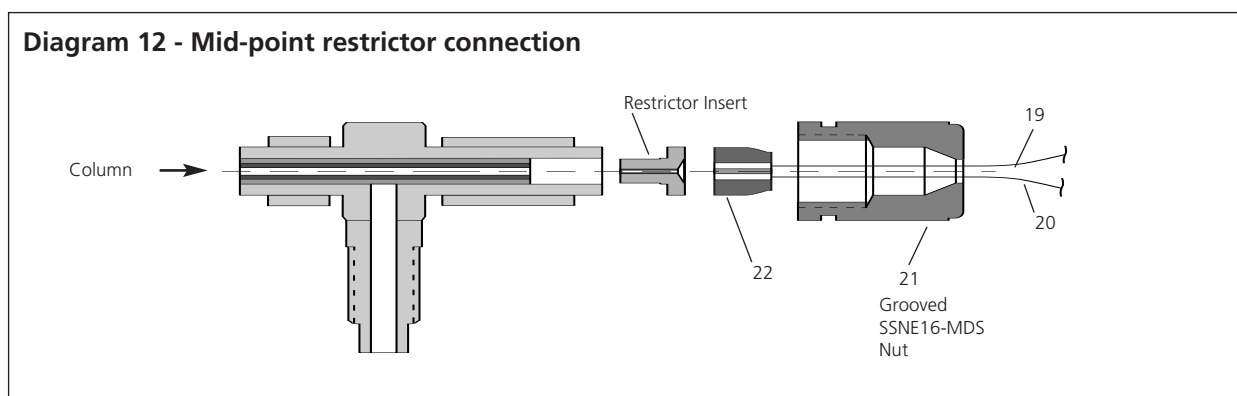



### **4.3 Balancing the Analytical Column and the Fused Silica Restrictor**

4.3.1. Set the pre-column pressure as desired (approximately 20psi), and the mid point pressure to 0. This pressure is normally dependant upon the pre-column and analytical column length and internal diameter. The mid point pressure will equilibrate. If it doesn't, there is a leak in the system. Re-check all connections.

4.3.2. Check the flow from the end of the fused silica restrictor and the analytical column. The object is to obtain an identical flow out of each. A soap bubble flow meter may be used to check the flow (supplied). To obtain identical flows, reduce the length of the fused silica restrictor by small amounts. A mini union (supplied) may be used to attach the bubble flow meter to the capillary column.

4.3.3. Once the flow are the same, connect the fused silica restrictor to the bottom of the MPPVT-MDS valve (12) via the VFF/0.2-0.35 stepped valve seat ferrule (13). Maintain slight pressure on the fused silica restrictor while tightening the ferrule.

4.3.4. Connect the analytical column to the analytical detector.

4.3.5. Carry out a full leak check on all components. It is useful to cycle the oven 2 or 3 times to the maximum conditioning temperature of the limiting column to "bed" in the ferrules. Re-check for leaks and re-tighten if necessary.

### **4.4 Optimizing the Mid-Point Restrictor**

Turn on all necessary heated zones and detector gases (Refer to HP 6890 operating manual). Set the auxiliary 4 make up flow to 30 ml/min (30-40 psi) which can be measured either at the fused silica transfer line to the monitor detector or at the 0.8mm ID side arm of the MPPVT-MDS valve. Since the make up supply to the detector is via the MPPVT-MDS valve, the internal make up supply to the monitor detector is set to 0 ml/min.

4.4.1. Set the mid-point pressure (auxiliary 3) at a desired flow rate for optimum carrier gas velocity through the analytical column.

4.4.2. Set the inlet pressure at approximately 1.5 times this value and inject a sample of methane or other suitable solvent.

If the inlet pressure is set above optimum, splitting of the test peak will occur at the mid-point restrictor and the response will be recorded at both detectors. If no response is noticed on the analytical detector, increase the front inlet pressure and re-inject.

4.4.3. Decrease the inlet pressure slightly after each injection until the pressure differential is reached. This is indicated by the test peak not showing up at the analytical detector. The correct pressure combination for normal heartcut and backflush operation has now been obtained.

4.4.4. This pressure "tuning" operation should only be required once for any particular combination of pre and analytical columns.

## 5.0 OPERATION.

### 5.1 General

All chromatography modes of the MDS HP6890 can either be controlled via the 6890 keyboard or via the Agilent Technologies (HP) Chemstation Software (recommended).

### 5.2 Software Configuration

5.2.1. In the INSTRUMENT menu, select EDIT PARAMETERS.

**Parameters only effecting the MDS HP6890 setup will be described below. For all other parameters, refer to the Hewlet Packard operating manual.**

5.2.2. In the VALVES menu, configure numbers 5 and 6 to switching valves. Each valve can be given a description name to identify it in the future. Label valve 5 to "heart-cut" and valve 6 to "cryogenic" or something similar.

5.2.3. In the COLUMNS menu, configure column 1 to the front inlet, and column 2 to pressure auxiliary #3. Also set the appropriate carrier gas type for both inlets. Set both modes to constant pressure, and set the appropriate column dimensions.

5.2.4. In the DETECTORS menu, turn off the make up supply to the monitor detector (usually the front detector).

5.2.5. In the AUX menu, select Pres Aux #3, give it a description such as "mid-point", and turn it on. The pressure setting for this channel can be set through the COLUMNS menu. Also configure this channel to the type of carrier gas that you are using. Now select "Pres Aux #4", label it as "MPPVT make-up", turn it on and select the type of make up gas. Set the pressure to 30 psi, and confirm approximately 25-30mL/min flow of make-up gas out of the MPPVT -MDS valve using a bubble flow meter. Adjust the pressure setting as required to obtain the correct flow.

5.2.6. In the RUNTIME menu, the appropriate on and off times for the heartcut times (valve 5) and cryogenic trap (valve 6) can be entered.

### 5.3 Split-Splitless Mode Injections

This operation is controlled as normally operated (refer Agilent Technologies (HP) Operation Instructions)

## 5.4 Backflush Operation

The backflush operation may be used to shorten analysis time, protect the analytical column from non-volatile or damaging materials, as well as protecting either the monitor or analytical detectors.

To initiate the Backflush mode, the operator sets the pre-column pressure (usually the front or rear injection port) to "0" at a pre-determined time while maintaining the mid point pressure and the injection port in the split mode. It is important the the pre-column be backflushed for at least as long a period of time as the sample components had been allowed to progress forward through the column.

Diagram 13. - Backflush

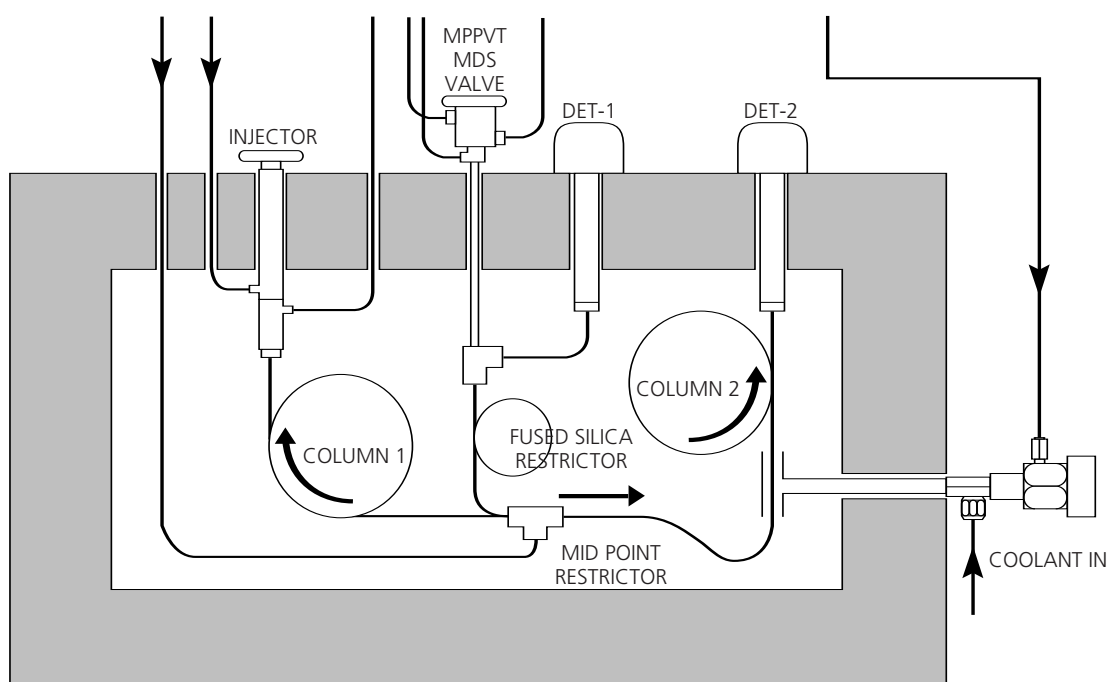

## 5.5 Variable Splitter Operation

This operation allows the establishment of a variable split of the Pre-Column effluent between the Monitor detector and the analytical column.

When the mid-point pressure is dropped below the value which is required for the heartcut or backflush operation a portion of the pre-column effluent is permitted across the mid-point restrictor into the analytical column. The desired Split ratio may be controlled by incrementally lowering the mid-point or increasing the pre-column pressure.

Diagram 14. - Variable Splitting

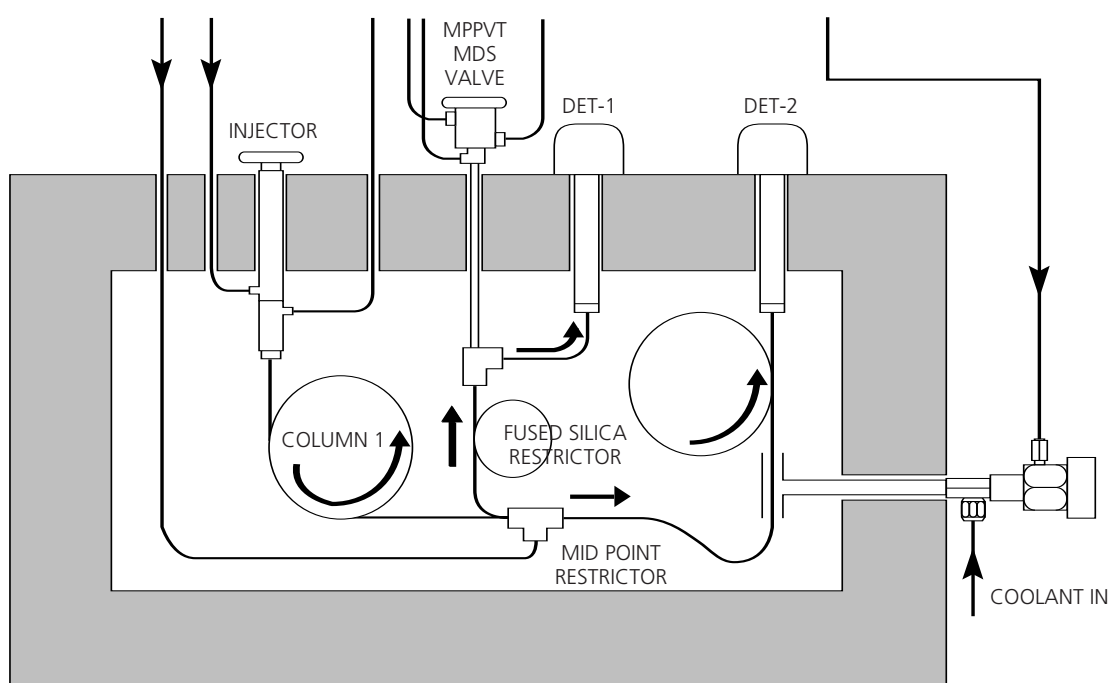

## 5.6 Heart-Cut Operation

The heart-cut capability makes possible the selective transfer of sections of the chromatographed components from the pre-column onto a second analytical column (usually of different polarity). Valve 5 is used to turn on and off the heartcut valve via the RUNTIME menu in HP Chemstation (revision A.04.01 or later). To heart-cut from the pre-column to the analytical column, simply program in the required event times of valve 5 in the RUNTIME menu. A diagram of both normal and heart-cut operating modes is shown below depending which valve is being used.

**Diagram 15. - Normal Operation**

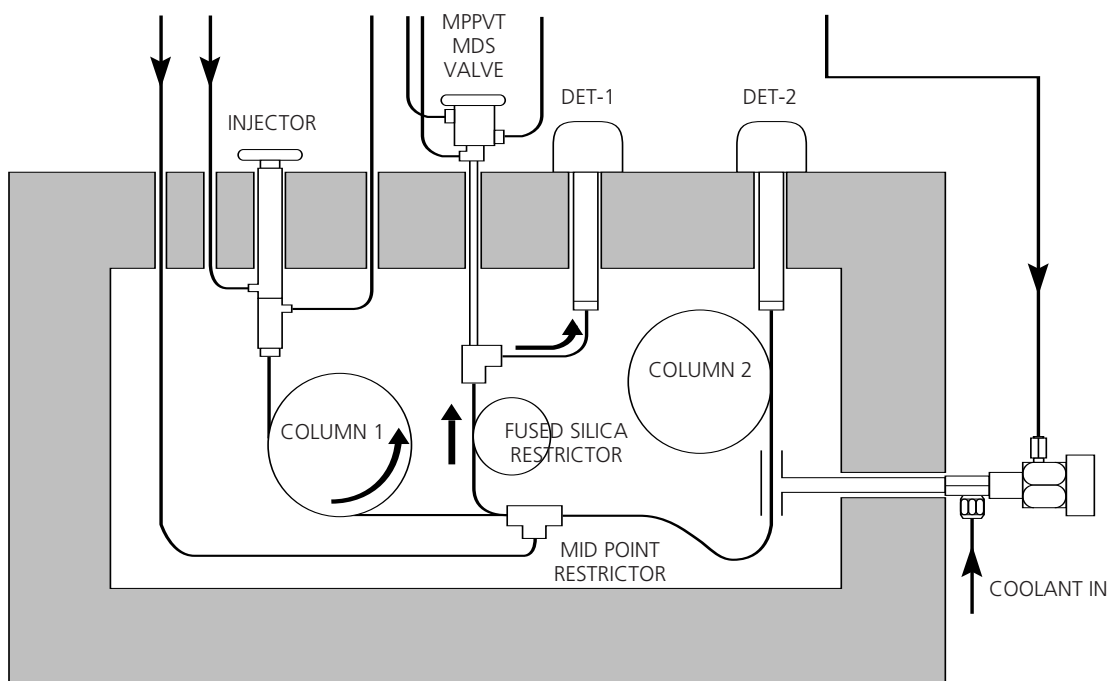

**Diagram 16. - Heart-cut**

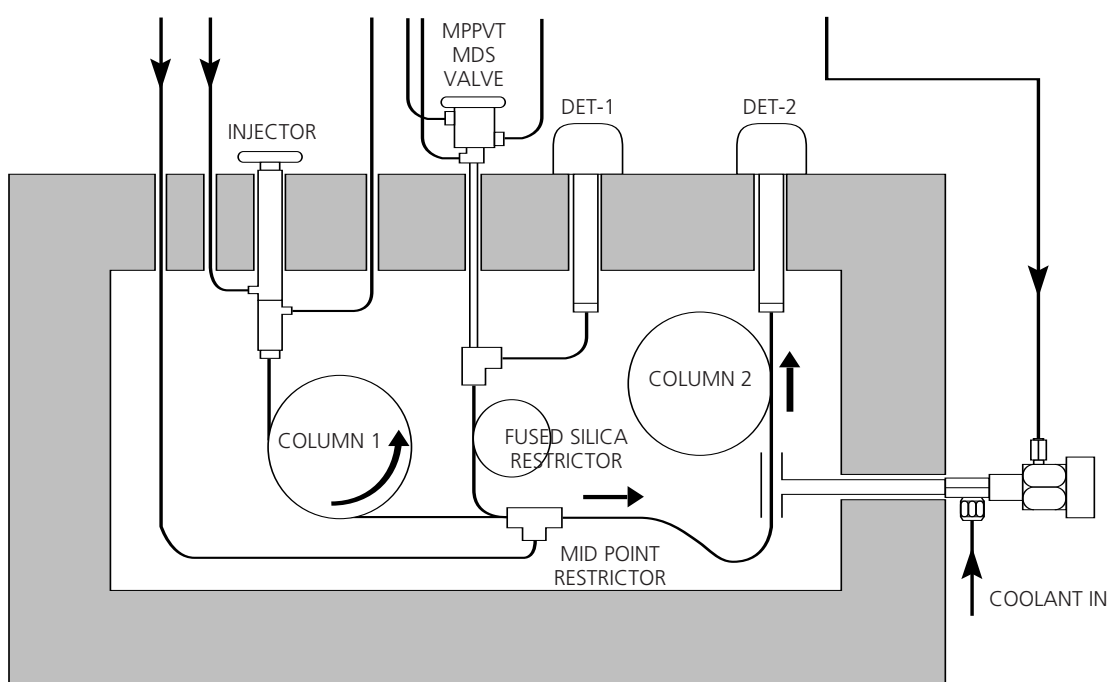

## 5.7 Cryogenic Cold Trap Operation

Valve 6 is used to operate the cryogenic coolant valve via the RUNTIME menu in HP Chemstation (revision A.04.01 or later). To turn on and off the cryogenic coolant, simply program in the required event times of valve 6 in the RUNTIME menu. The cryogenic valve needs to be turned on approximately 1 minute prior to any heart-cut operation to ensure it has reached temperature (approx. -60°C at 50°C oven temperature), and turned off either at the end of the first temperature program run after all the heart-cut events, or it can be cycled on and off after each heart-cut event depending on the desired chromatographic result.

For further information please contact...

### **UNITED STATES OF AMERICA**

SGE, Incorporated (USA)  
Tel: +1 512 837 7190  
Toll Free: 800 945 6154  
Fax: +1 512 836 9159  
Email: usa@sge.com

### **AUSTRALIA AND PACIFIC REGION**

SGE International Pty Ltd  
Tel: +61 (0) 3 9837 4200  
Toll Free: 1800 800 167  
Fax: +61 (0) 3 9874 5672  
Email: support@sge.com

### **UNITED KINGDOM**

SGE Europe Ltd. (UK)  
Tel: +44 (0) 1908 568 844  
Fax: +44 (0) 1908 566 790  
Email: uk@sge.com

### **FRANCE**

SGE (France) sarl  
Tel: +33 (0) 1 6929 8090  
Fax: +33 (0) 1 6929 0925  
Email: france@sge.com

### **GERMANY**

SGE (Deutschland) GmbH  
Tel: +49 (0) 6151 860486  
Fax: +49 (0) 6151 860489  
Email: germany@sge.com

### **ITALY**

SGE Italia srl  
Tel: +39 06 4429 0206  
Fax: +39 06 4429 0724  
Email: sge.italia@tin.it

### **JAPAN**

SGE Japan Inc.  
Tel: +81 (045) 222 2885  
Fax: +81 (045) 222 2887  
Email: japan@sge.com

### **INDIA**

SGE Laboratory Accessories Ptv Ltd  
Tel: +91 (022) 2471 5896  
Fax: +91 (022) 2471 6592  
Email: sgeindia@vsnl.com

### **CHINA**

SGE China Service Centre  
Tel: +86 (10) 6588 8666  
Fax: +86 (10) 6588 6577



[www.sge.com](http://www.sge.com)

SGE Offices