

SINGER



SLANT-O-MATIC

403 Special

T H E S I N G E R M A N U F A C T U R I N G C O M P A N Y

Instructions for using

SINGER*

SLANT-O-MATIC*

Special

403*

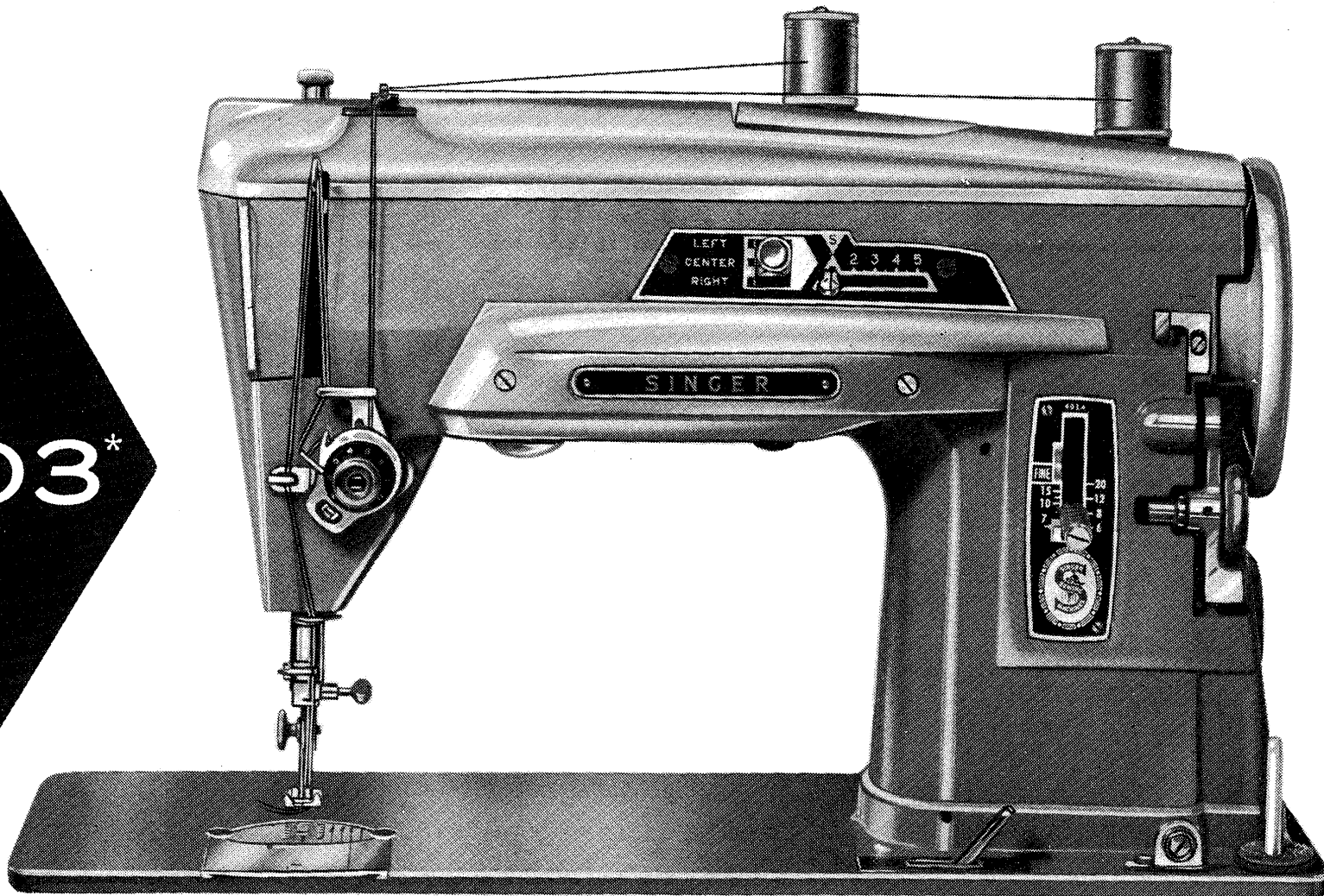

The *SLANT-O-MATIC* Special . . . the finest semi-automatic sewing machine ever built!

*A Trademark of THE SINGER MANUFACTURING COMPANY

The *SLANT-O-MATIC* Special . . .

With the purchase of the new *SLANT-O-MATIC* Special you can take pride in owning the “best”. The only semi-automatic slant needle machine for home use that is made entirely in America. You will marvel at its almost unbelievable ease of operation . . . the remarkable services it performs. You will delight in the outstanding quality of its stitching—straight, zigzag and ornamental.

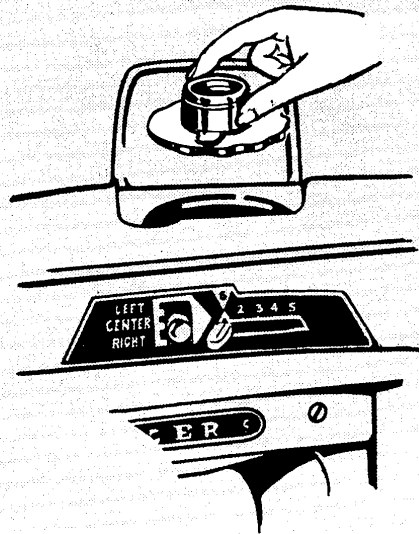
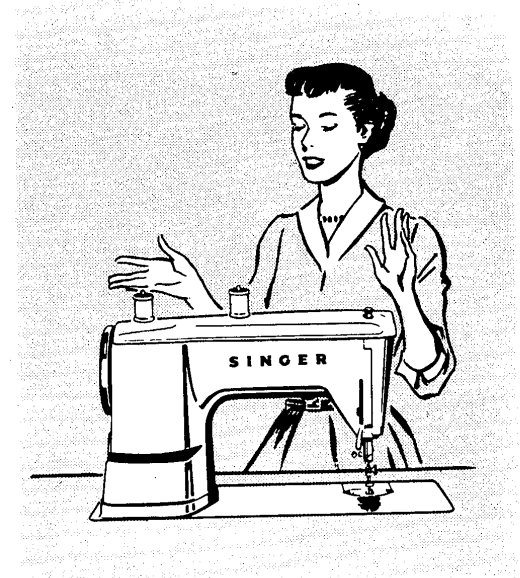

- *World's first* semi-automatic with a slant needle and gear drive. Seeing is easier, sewing smoother. No slipping or stalling.
- *World's first* semi-automatic with “double easy” threading. Has a built-in threading chart.
- *World's first* semi-automatic with a handy “drop-in” bobbin in *front* of needle.

Add to these major developments in sewing machine design the following advanced features, and you have a sewing machine unsurpassed by any other semi-automatic.

- **ELEVATOR TYPE** multi-purpose calibrated throat plate, lever operated, simplifies darning.
- **HINGED** face plate with built-in threading chart, swings open for easy oiling and cleaning.
- **SUPERFINE CONTROL** of stitch length insures perfect satin stitching.
- **PERFECT** straight stitching.
- **INTERCHANGEABLE FASHION* DISCS**, one piece, easy to handle.

- **BUILT-IN LIGHT** focused on sewing area.
- **NEEDLE CLAMP** holds two regular needles . . . same or different sizes for interesting two-needle stitching.
- **ALL MECHANISM** completely enclosed.
- **ADJUSTABLE HINGED** zipper and cording foot.
- **SPECIAL PURPOSE FOOT** for accurate placement of satin stitching.
- **SEAM GUIDE** . . . flexible, multi-purpose. Simplifies blind stitching.

TO GET THE MOST ENJOYMENT FROM YOUR SINGER

Take advantage of the free sewing lessons to which you are entitled! Skilled, SINGER-trained teachers will give you personal guidance and assist you in learning the fundamentals of home sewing.



SINGER SERVICE

Wherever you go you will find expert, dependable SINGER* Service close at hand. SINGER is interested in helping you keep your SINGER Sewing Machine in top running condition. That is why you should always call your SINGER SEWING CENTER if your machine ever requires adjustment or repair. Only from your SINGER SEWING CENTER can you obtain the services of a trained SINGER repair man and warranted SINGER* parts.



EVERYTHING FOR THE WOMAN WHO SEWS

The answer to your sewing needs is at your SINGER SEWING CENTER. There you will find a wide choice of sewing aids, notions, sewing instructions and services. Look for the famous red "S" and SINGER trademarks on your SINGER SEWING CENTER and the ever ready SINGER Service Car. See phone book under SINGER SEWING MACHINE CO. for address nearest you.

FABRIC, THREAD, NEEDLE AND STITCH LENGTH CHART

TYPES OF FABRICS	THREAD SIZES	NEEDLE SIZES	MACHINE STITCH SETTINGS FOR STRAIGHT SEWING	
			INSIDE SEAMS	TOP STITCHING
Filmy materials comparable to Net, Marquissette, Chiffon, Silk and Chiffon Velvets, Voiles, Ninon	50 Embroidery 100 Cotton Synthetic Thread	9	15 to 20	15 to 20
Sheer materials comparable to Lawn, Dimity, Synthetic Sheers, Paper Taffetas, Pure Silks, Gossamer Silks, Silk or Synthetic Tricots, Synthetic Velvets, Satins	50 Embroidery 80 to 100 Cotton Synthetic Thread	11	12 to 15	15 to 20
Lightweight materials comparable to Gingham, Chambray, Pique, Poplin, Percalé, Cretonne, Chintz, Faille, Bengaline, Wool Flannel, Wool Jersey, Wool Crepe, Cotton Velvets and Velveteens, Lightweight Suitings	50 Mercerized 60 to 80 Cotton A Silk	14 or 16	12	15 to 18
Medium heavy materials comparable to Corduroy, Crash, Gabardine, Rep, Heavy Suitings and Coatings	Heavy Duty Mer. 40 to 60 Cotton Synthetic Thread	16	10	12
Heavy materials comparable to Sailcloth, Denim, Ticking, Overcoatings	30 to 40 Cotton Thread	18	8	10
Plastic Materials	50 Embroidery Synthetic Thread 50 Mercerized	11 or 14	10	12

When ordering needles, always specify "Class and Variety 15 x 1" and state the size and quantity required.

NEEDLES AND THREAD

This machine uses a 15 x 1 needle.
Sizes 9, 11, 14, 16 and 18.

For perfect stitching, select correct needle and thread to correspond with fabric according to table on **page 5**. Be sure to use like threads for both needle and bobbin.

NEEDLE INSERTION

Raise the needle bar to highest point by turning the hand wheel toward you. Loosen the needle clamp screw. Insert needle upward into clamp as far as it will go, with the flat side of the needle to the back and the **long groove toward you**. Tighten needle clamp screw.

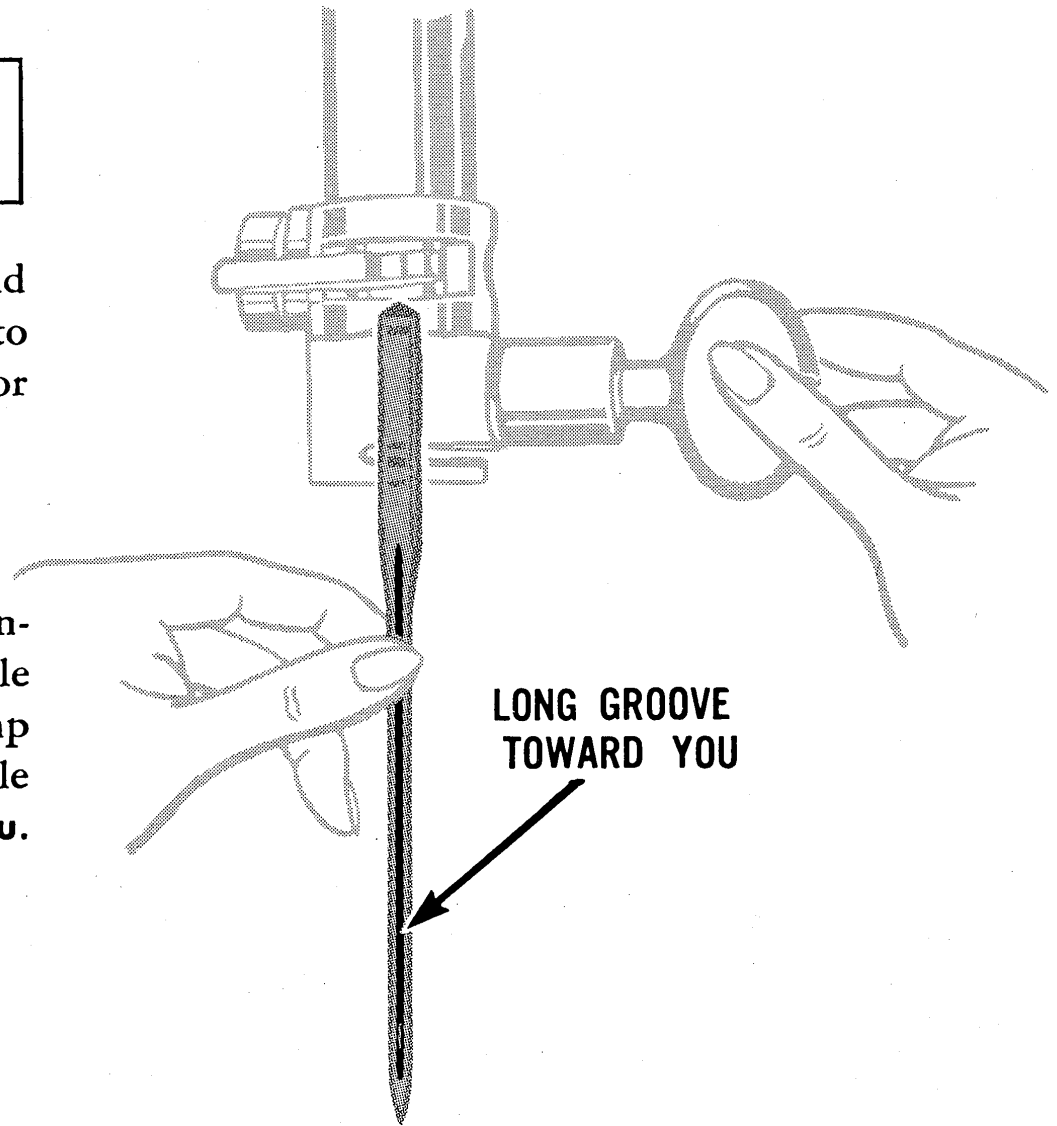

UPPER THREADING—SINGLE NEEDLE

Raise take-up lever to highest point. Place thread on spool pin and lead through threading points shown. Thread needle from front to back. Draw sufficient thread through eye of needle with which to start sewing.

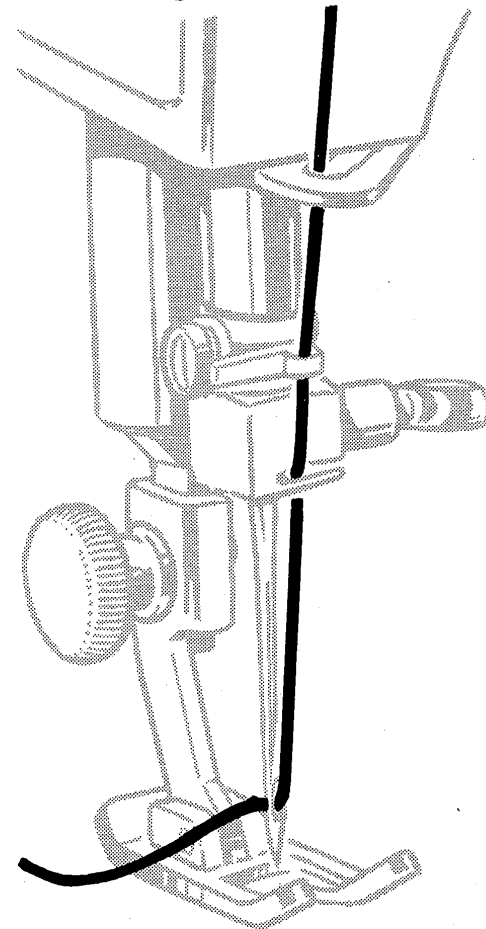
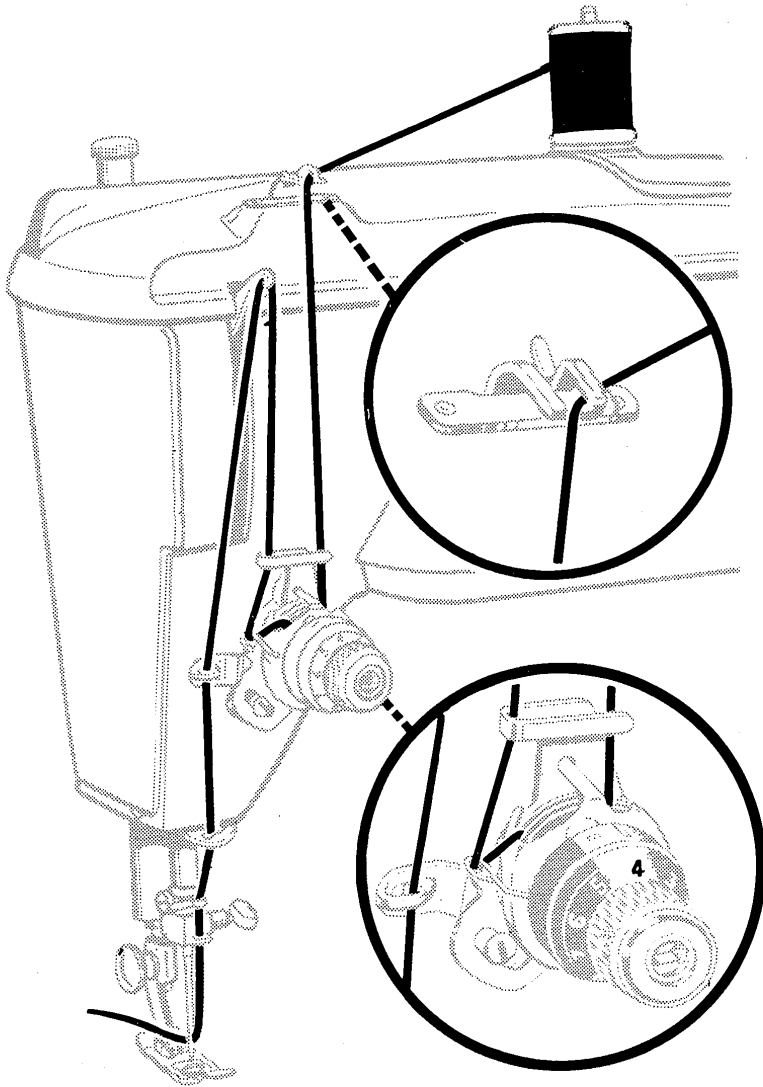

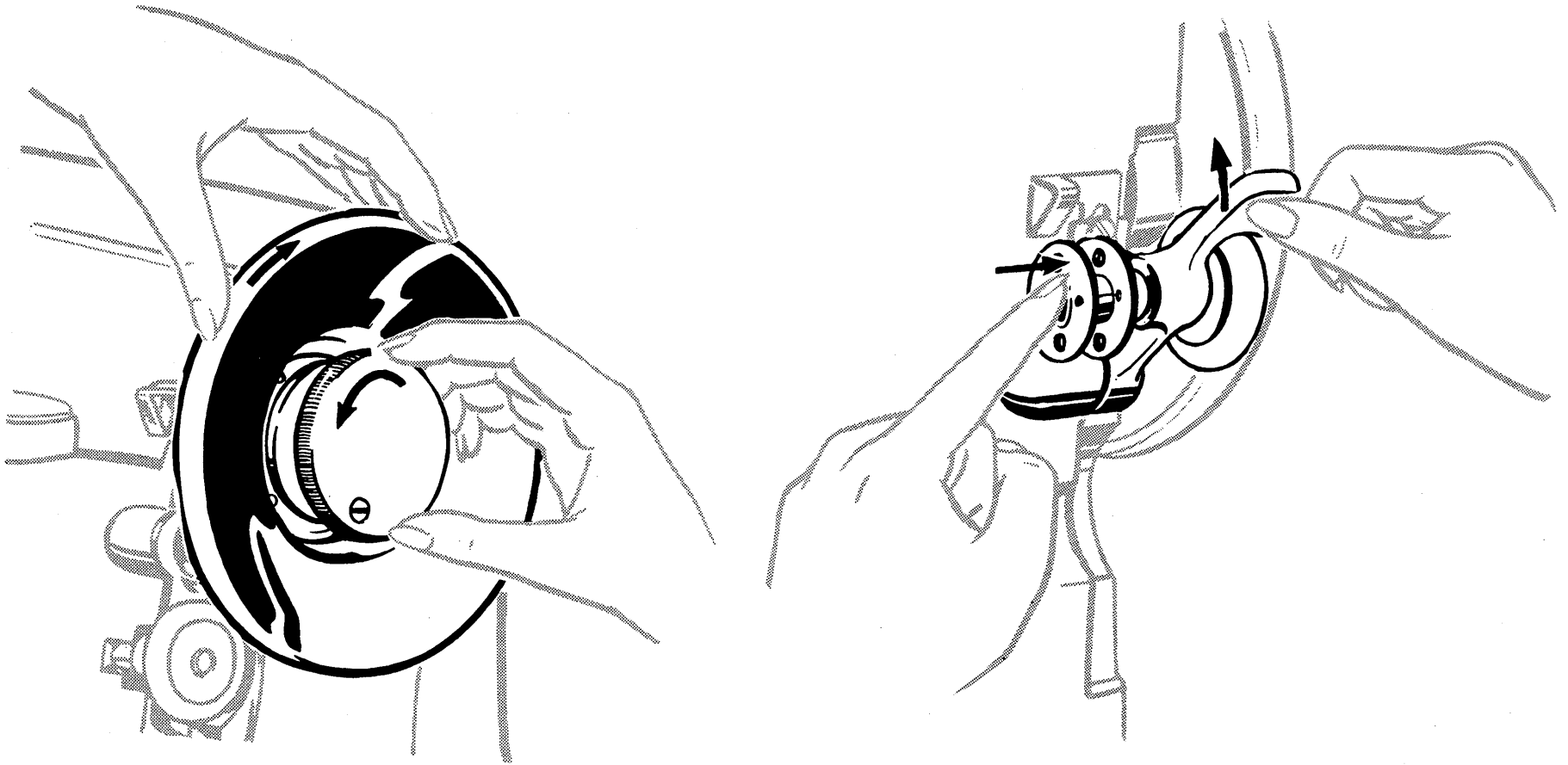
WIND THE BOBBIN

Loosen stop motion screw with right hand. Raise bobbin winder and position bobbin on spindle. Press winder against hand wheel.

WIND THE BOBBIN (Cont'd.)

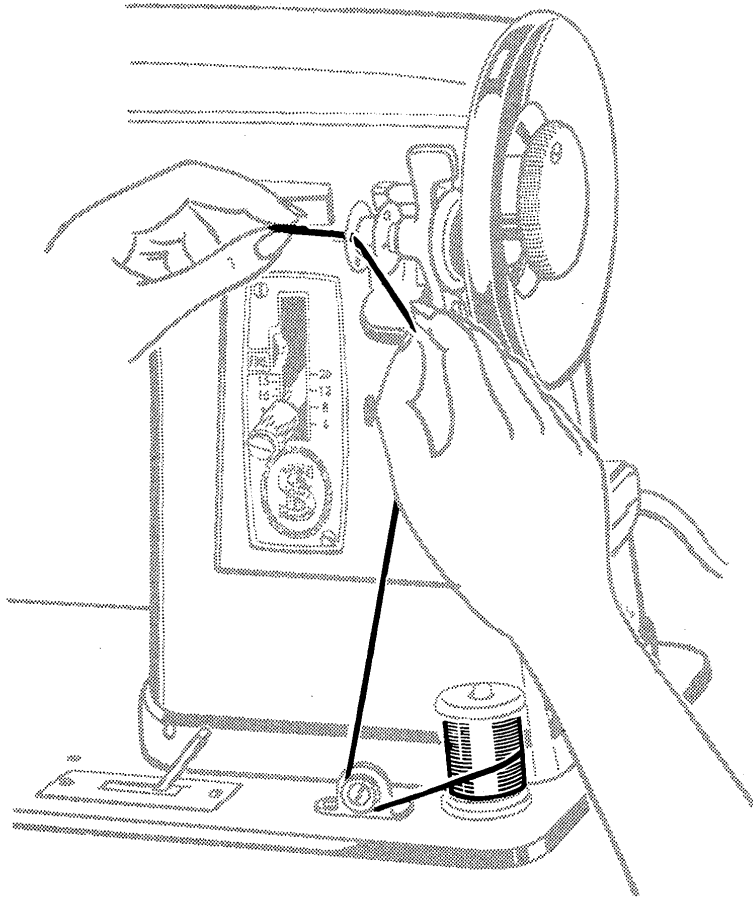

Place thread on spool pin and lead between bobbin winder tension discs. Thread through hole in left side of bobbin as shown.

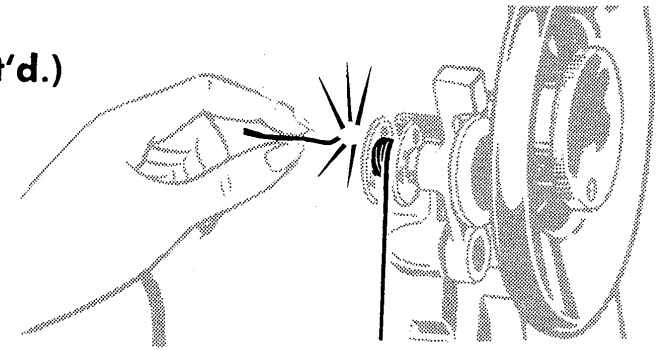

Hold thread end to start winding. Activate machine.

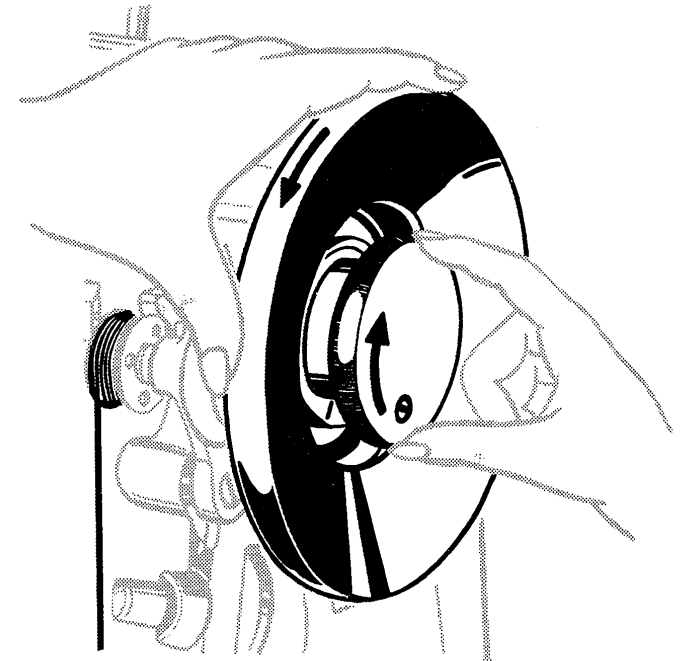

Full bobbin will automatically release. Tighten stop motion screw.

REMOVE THE BOBBIN

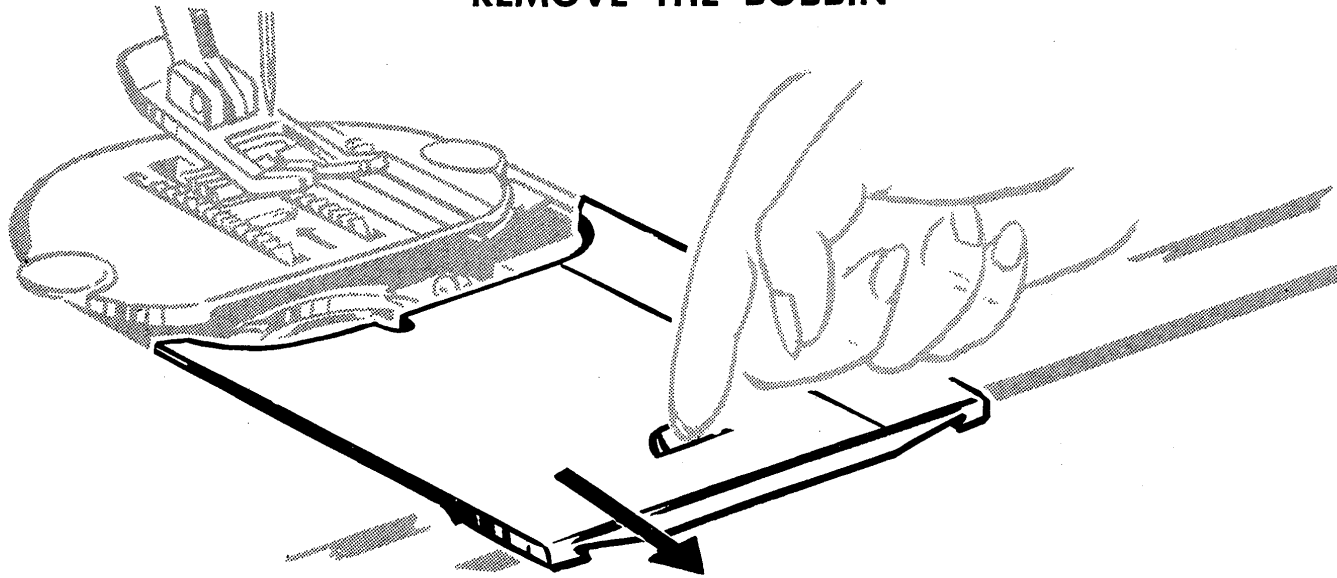

Open slide plate and remove bobbin.

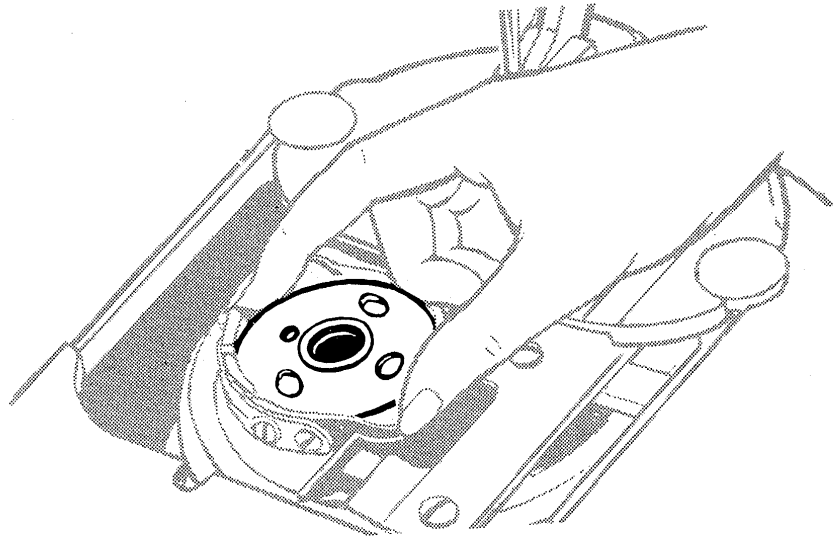

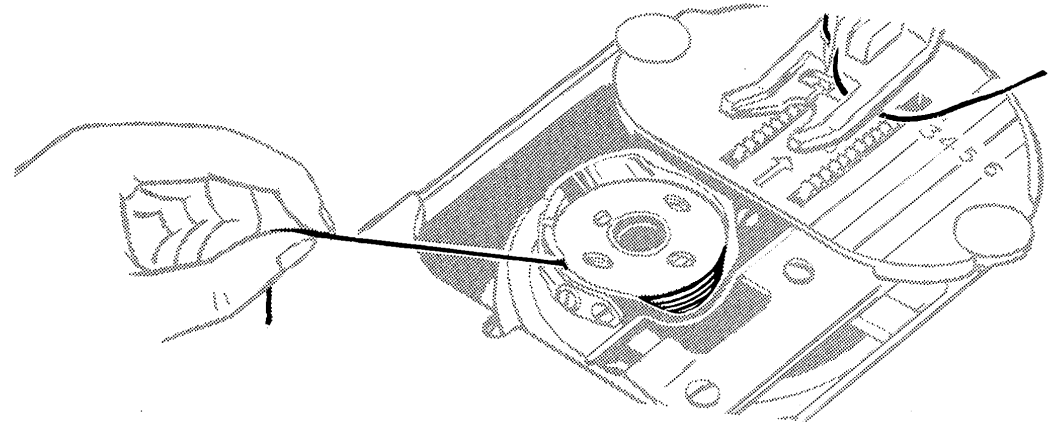
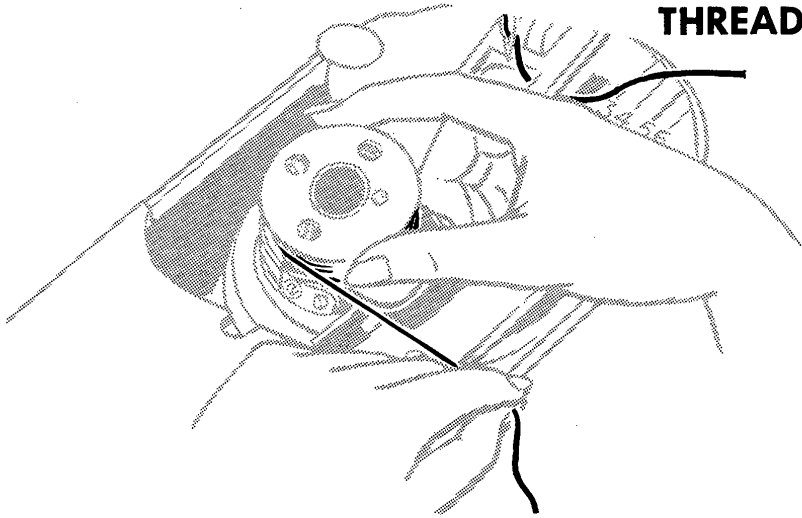
THREADING THE BOBBIN CASE

Hold bobbin so that thread leads off, in direction shown. Place bobbin in case. Lead thread into slot and under spring.

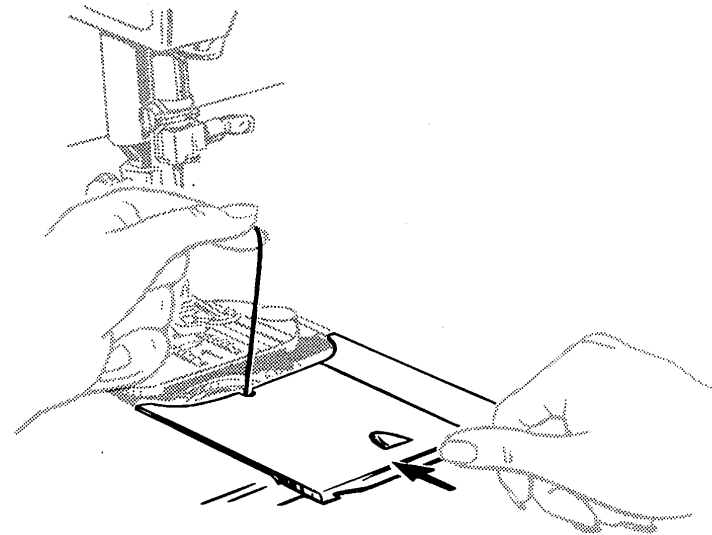
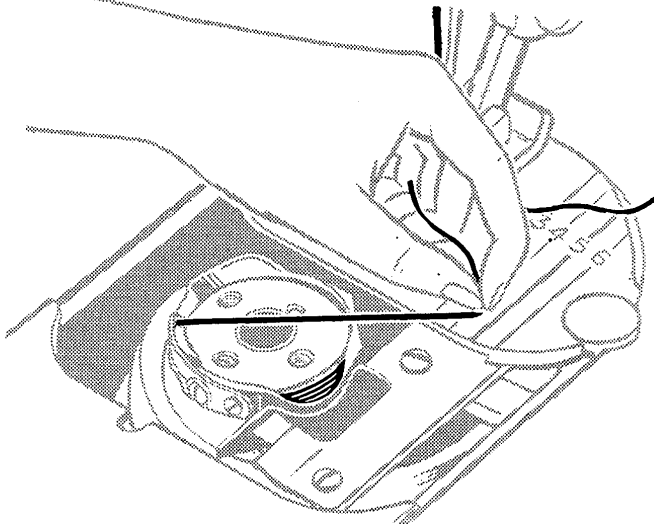

Draw thread into notch at end of spring, pulling off about 3 inches of thread across the bobbin. Close slide plate allowing thread to enter notch.

PRINCIPAL PARTS OF MACHINE 403

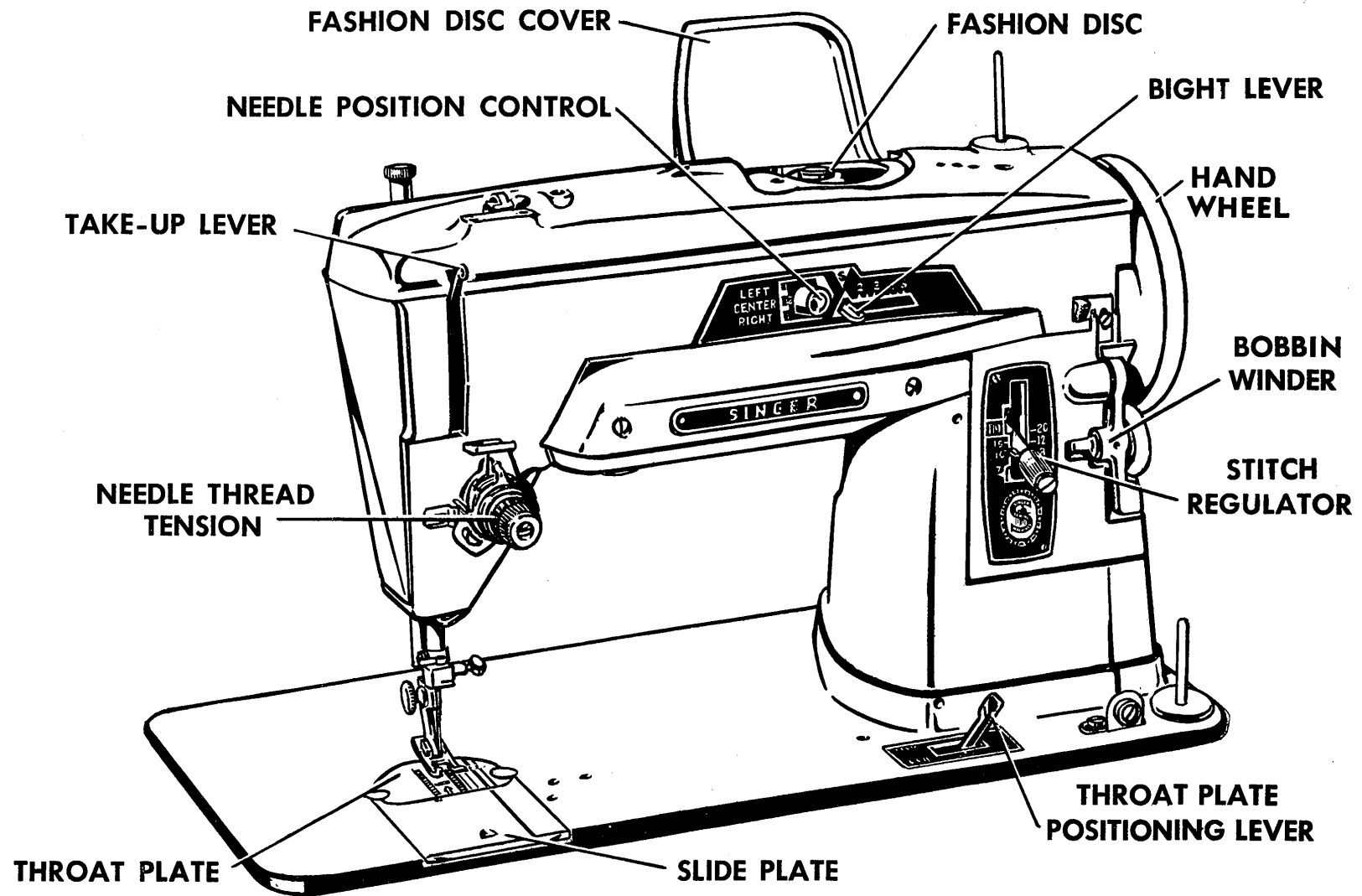

STITCH LENGTH REGULATOR

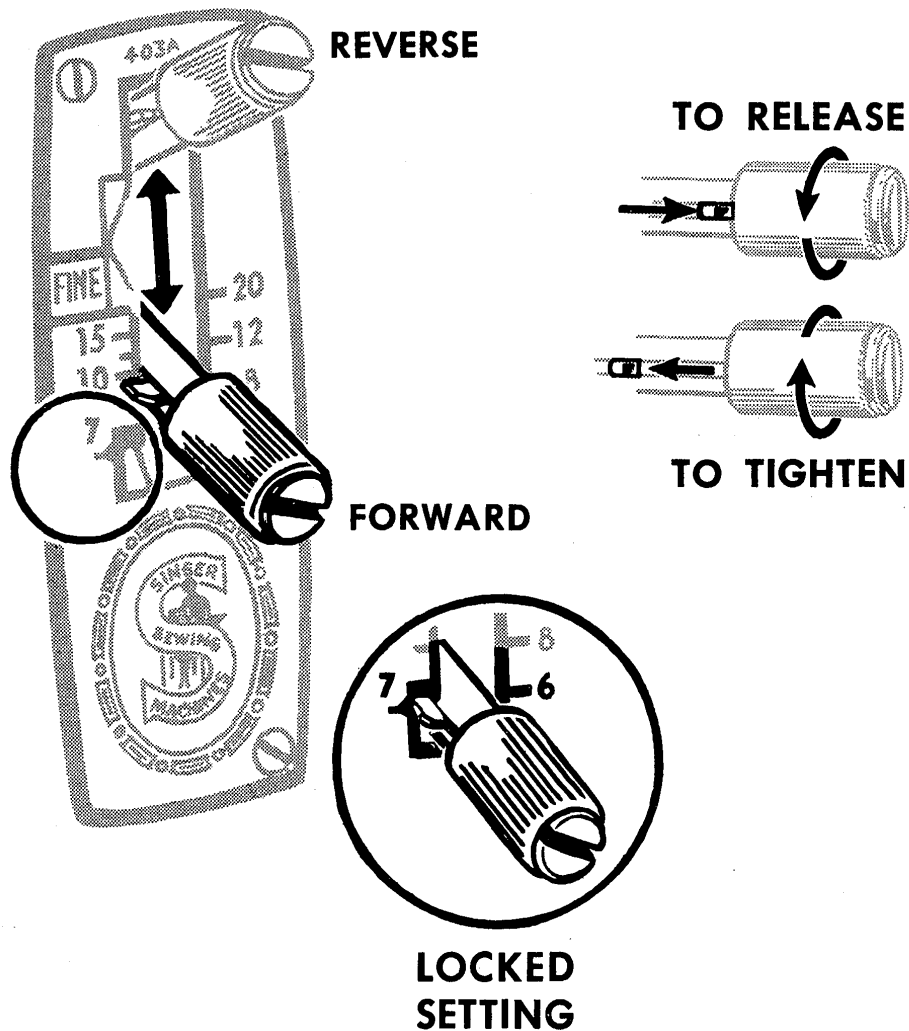

Numerals on the indicator represent the number of stitches per inch.

The upper indented area of the regulator represents “fine” stitch lengths above 20.

The lower indented area of the regulator allows the #6 stitch length setting to be “locked” in place when stitching folds, pleats or multiple layers of heavy fabric.

To set stitch length: Release pointer by turning thumb nut to the left, as shown. Position lever for desired stitch length. Tighten pointer against the plate by turning thumb nut to the right.

Once the pointer has been positioned, reverse stitching is accomplished by raising the lever to its highest point. The #6 “locked” position cannot be reversed.

NEEDLE POSITION SELECTOR

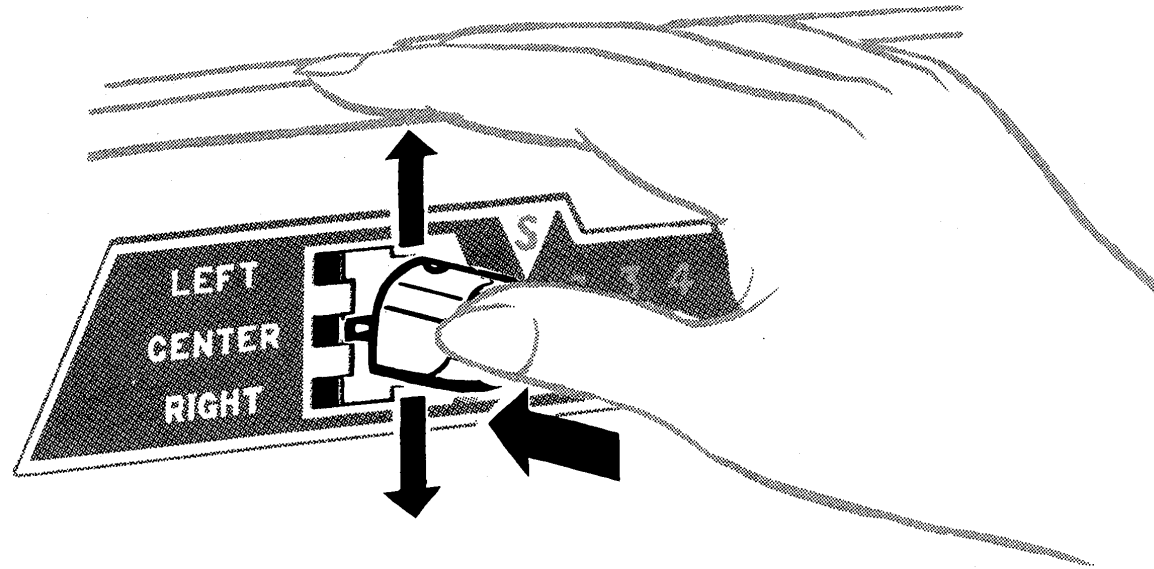

- PUSH
- SELECT
- RELEASE

LEFT, CENTER and RIGHT needle position settings are available for the placement of both straight and zigzag stitching.

To position, push control in with the thumb and raise or lower to desired setting.

Do not make any needle position adjustments while the needle is in the fabric.

BIGHT SELECTOR

STRAIGHT STITCH SETTING "S"

ZIGZAG WIDTH SETTINGS 2 TO 5

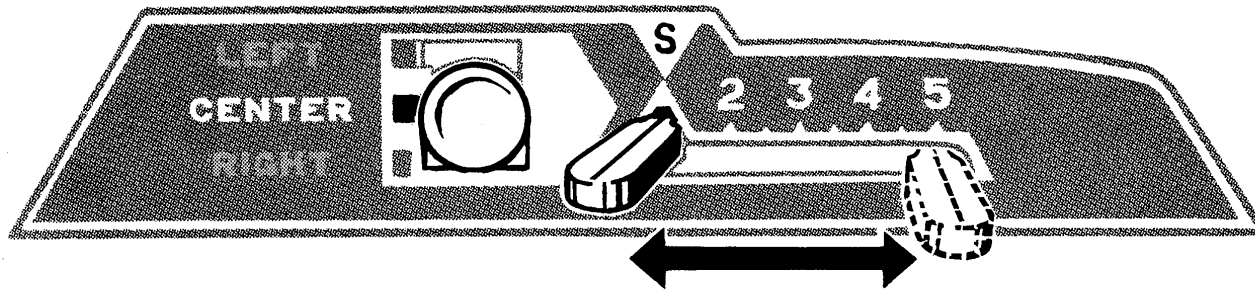

The Bight Lever regulates the swing of the needle from its straight stitching position "S" (zero bight) to its maximum width position 5 ($\frac{3}{16}$ inch bight).

To position, depress lever and slide it left or right to the setting desired. Numerals indicate four width settings, but intermediate settings may also be used.

Do not make any Bight Lever adjustments while the needle is in the fabric.

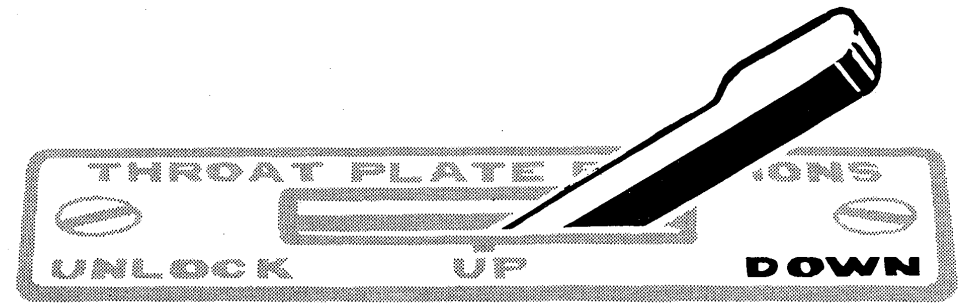
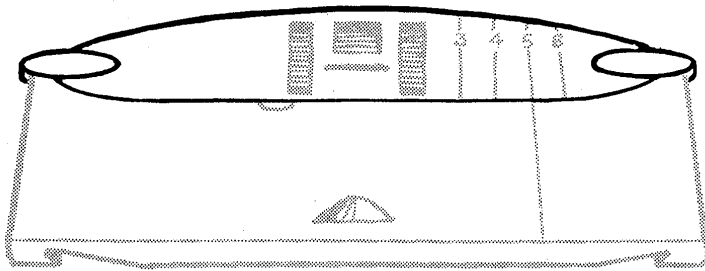
THROAT PLATE POSITIONS

Throat plate in "Down" position for general sewing.

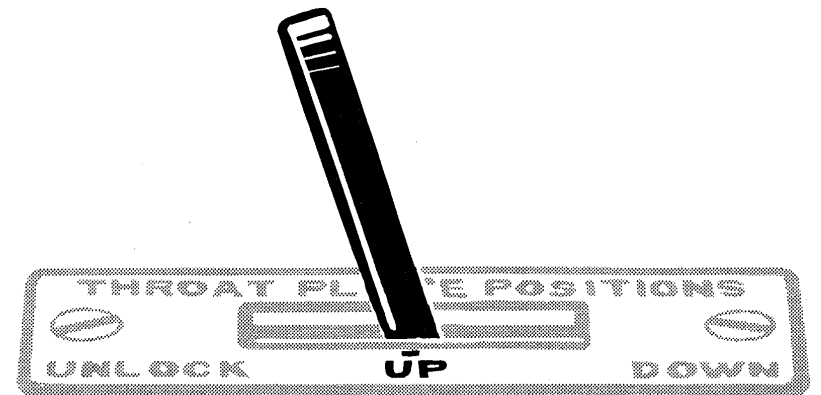
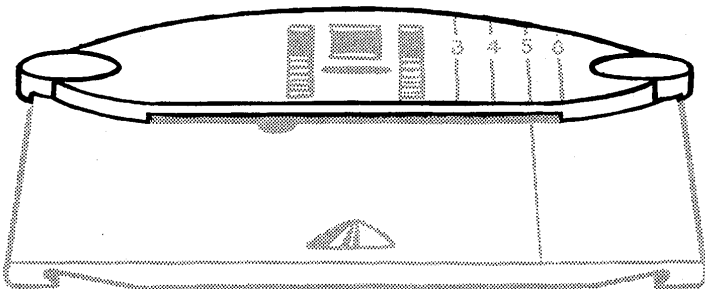

Throat plate in "Up" position for darning, embroidering and button sewing.

THROAT PLATE

REMOVAL AND REPLACEMENT

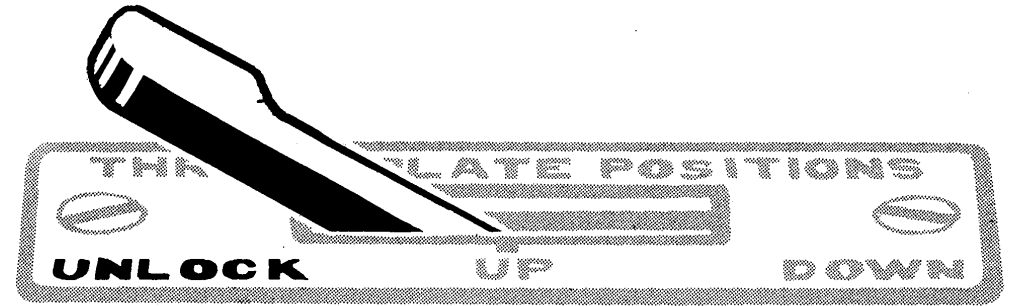
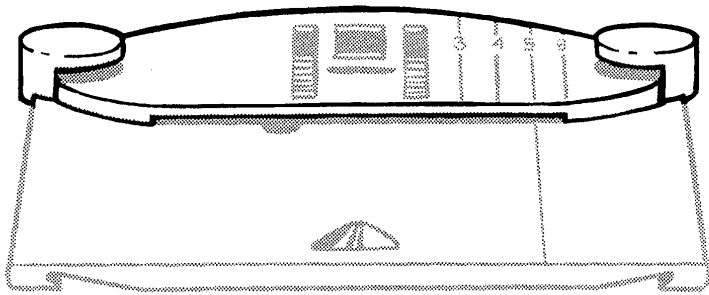

Throat plate in "Unlock" position for removal and replacement.

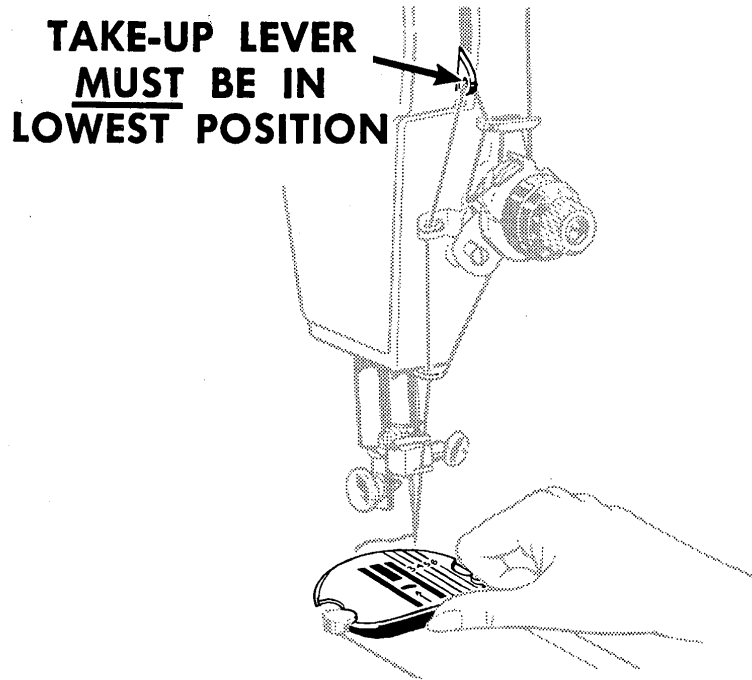

Raise presser bar. Turn hand wheel to drop take-up lever to its lowest point. Set throat plate lever to "Unlock" position. This preparation applies to both removal and replacement.

Remove throat plate by sliding it back.

Replace throat plate by sliding it on from the rear.

Lock in position.

Presser foot need not be removed for this operation.

STRAIGHT STITCHING

CENTER POSITION

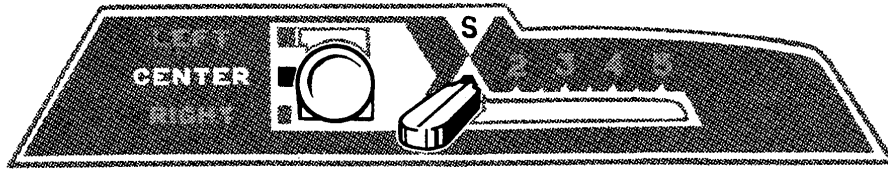

SET BIGHT CONTROL AT "S"
NEEDLE POSITION AT "CENTER"
GENERAL PURPOSE THROAT PLATE
AND PRESSER FOOT
OR
STRAIGHT STITCH THROAT PLATE
AND PRESSER FOOT (See Page 20)

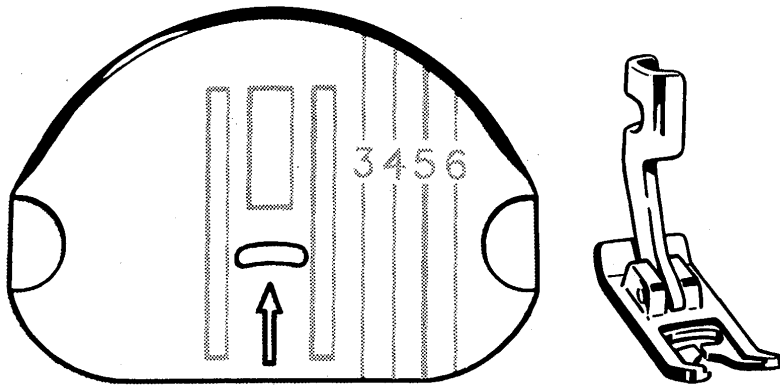

GENERAL PURPOSE THROAT PLATE
GENERAL PURPOSE PRESSER FOOT

— OR —

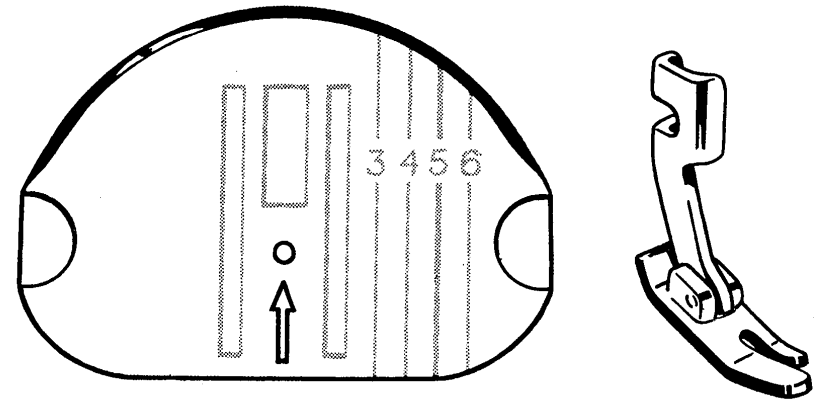

STRAIGHT STITCH THROAT PLATE
STRAIGHT STITCH PRESSER FOOT

STRAIGHT STITCHING SECONDARY POSITIONS

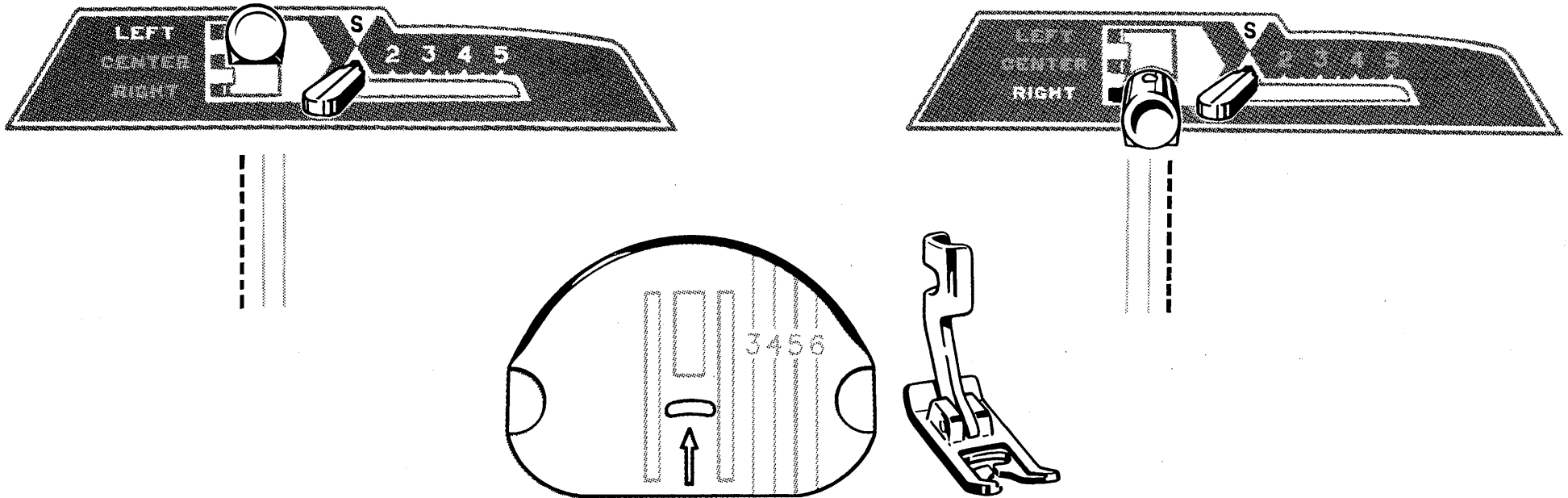

SET BIGHT CONTROL AT "S"
 NEEDLE POSITION AT "LEFT" OR "RIGHT"
 GENERAL PURPOSE THROAT PLATE AND PRESSER FOOT

To meet special requirements a line of stitching may be placed to the right or left of center. The general purpose throat plate and presser foot *must* be used with these secondary needle positions.

STRAIGHT STITCHING EQUIPMENT

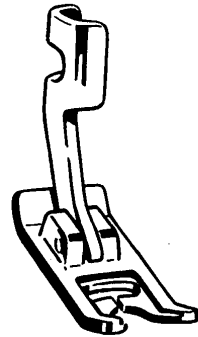
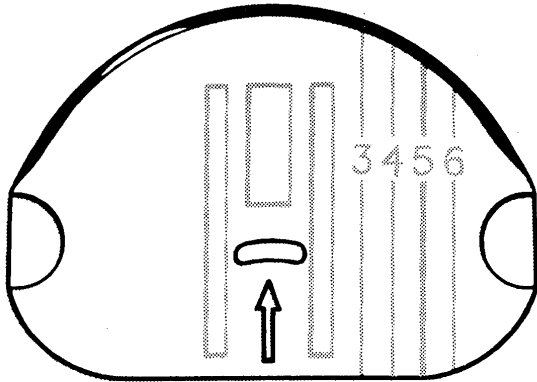

THE GENERAL PURPOSE THROAT PLATE AND PRESSER FOOT are used for all utility sewing, long straight seams, etc., and where there is occasion to alternate between straight and zigzag stitching in the sewing procedure.

The general purpose equipment must be used when placing a line of stitching to the left or right of center to meet special requirements.

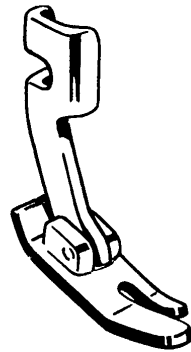
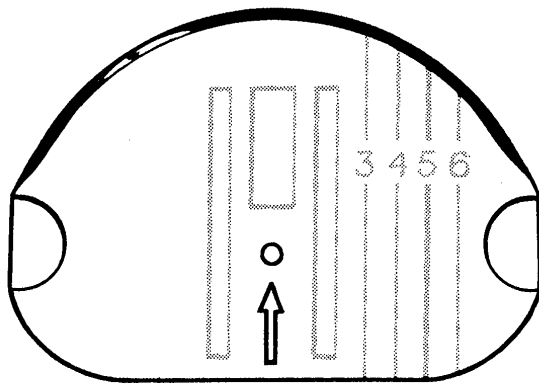

THE STRAIGHT STITCHING THROAT PLATE AND PRESSER FOOT are used where fabric or sewing procedure require close control . . . for the precision stitching of curved and scalloped edges, top stitching, edgestitching, etc. This equipment should be used when stitching sheer and filmy fabrics, knits and tricots (particularly synthetics) and all soft spongy materials.

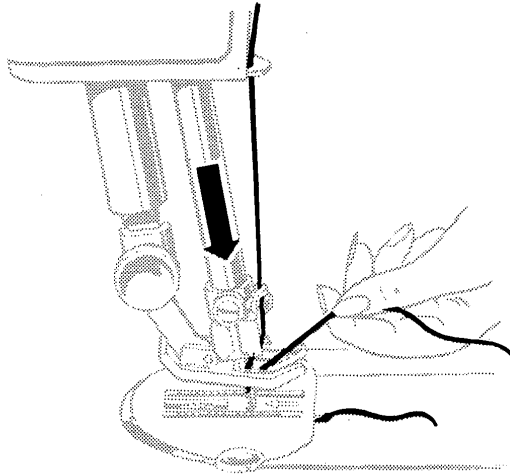
PREPARE TO SEW

Hold needle thread lightly with left hand. Turn hand wheel so that needle enters plate and brings up bobbin thread.

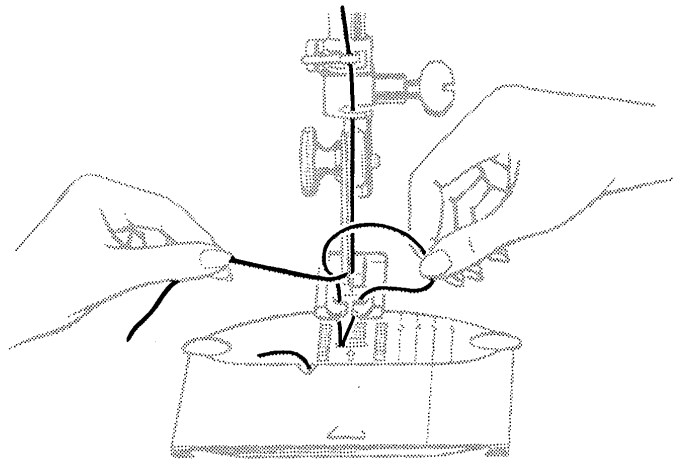
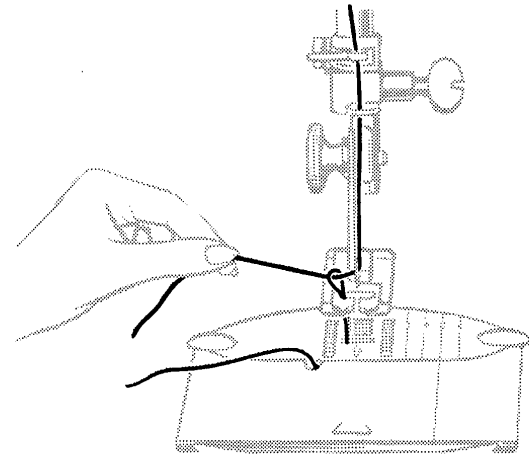

Pull end of bobbin thread through plate and place both needle and bobbin threads diagonally under presser foot.

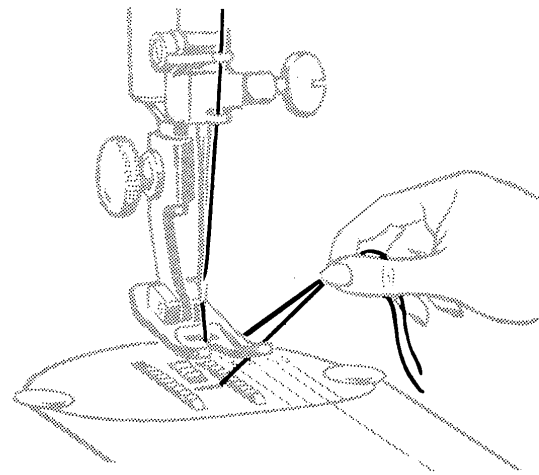

SEWING A SEAM

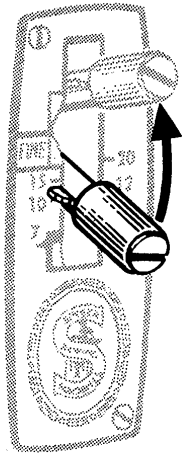
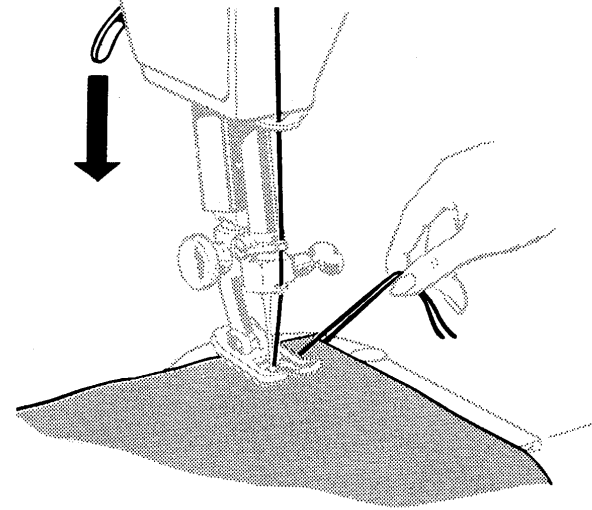
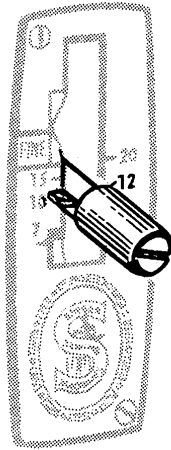
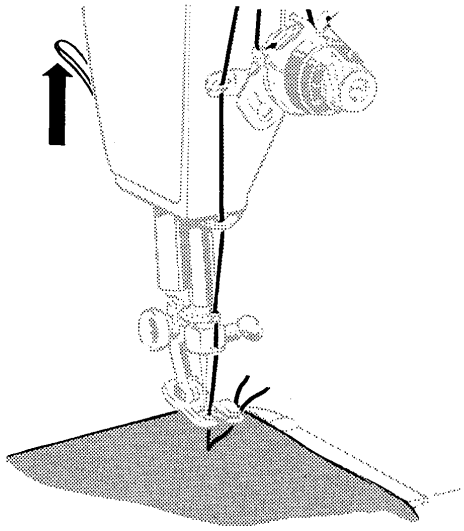

Set stitch regulator for stitch length desired. Position needle into fabric about $\frac{1}{2}$ inch from edge and lower presser foot. Raise stitch regulator to reverse.

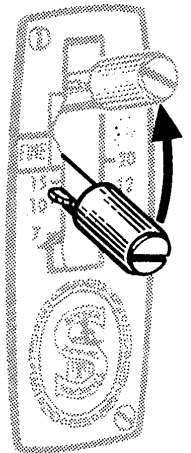
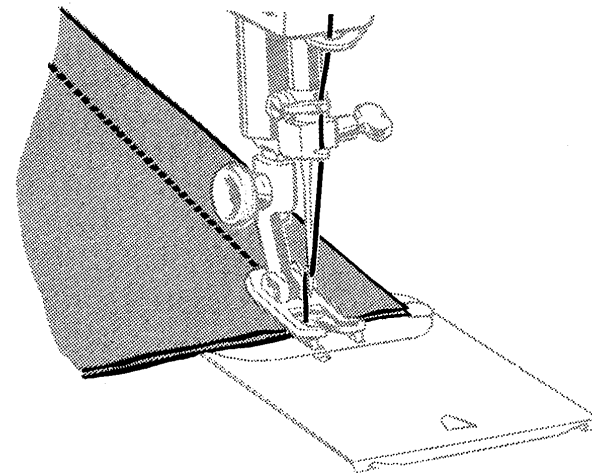
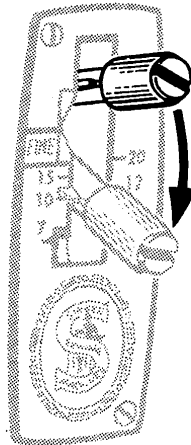
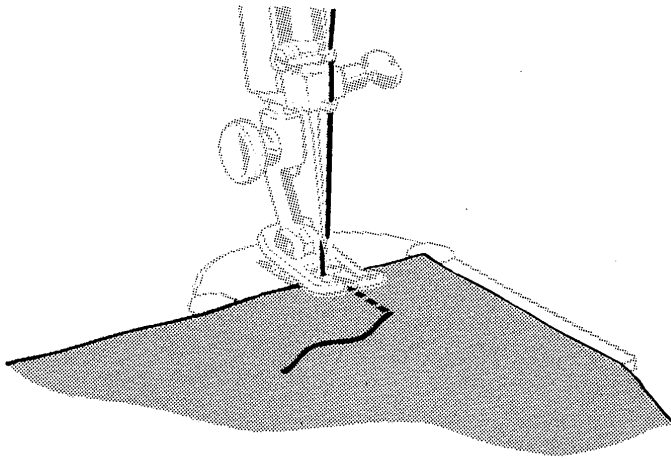

Back stitch to edge of fabric for reinforcement. Lower regulator for forward stitching of seam. Raise stitch regulator.

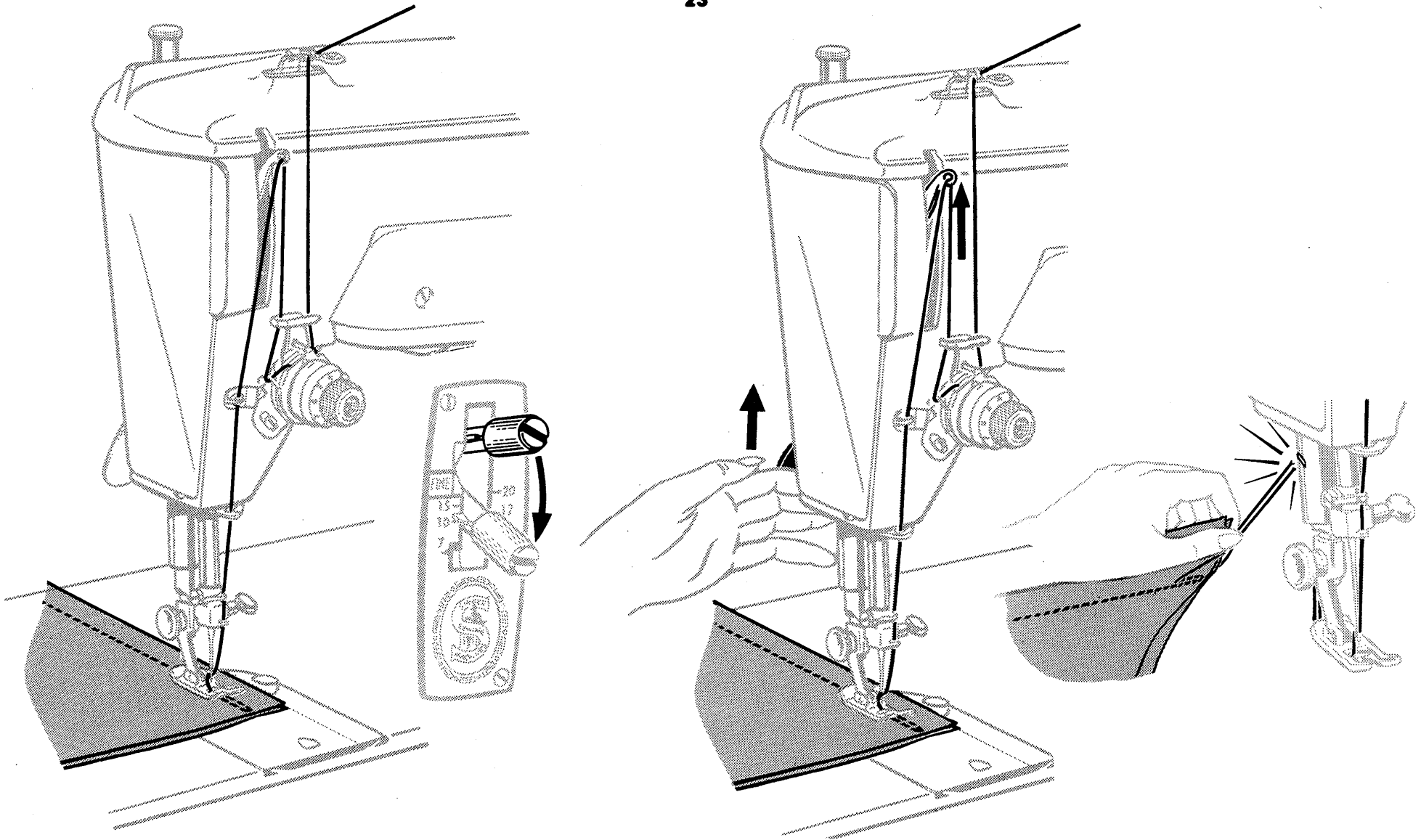

Back stitch to reinforce end of seam, and lower regulator to forward stitching position.

With take-up lever at highest point, raise presser foot and remove fabric.

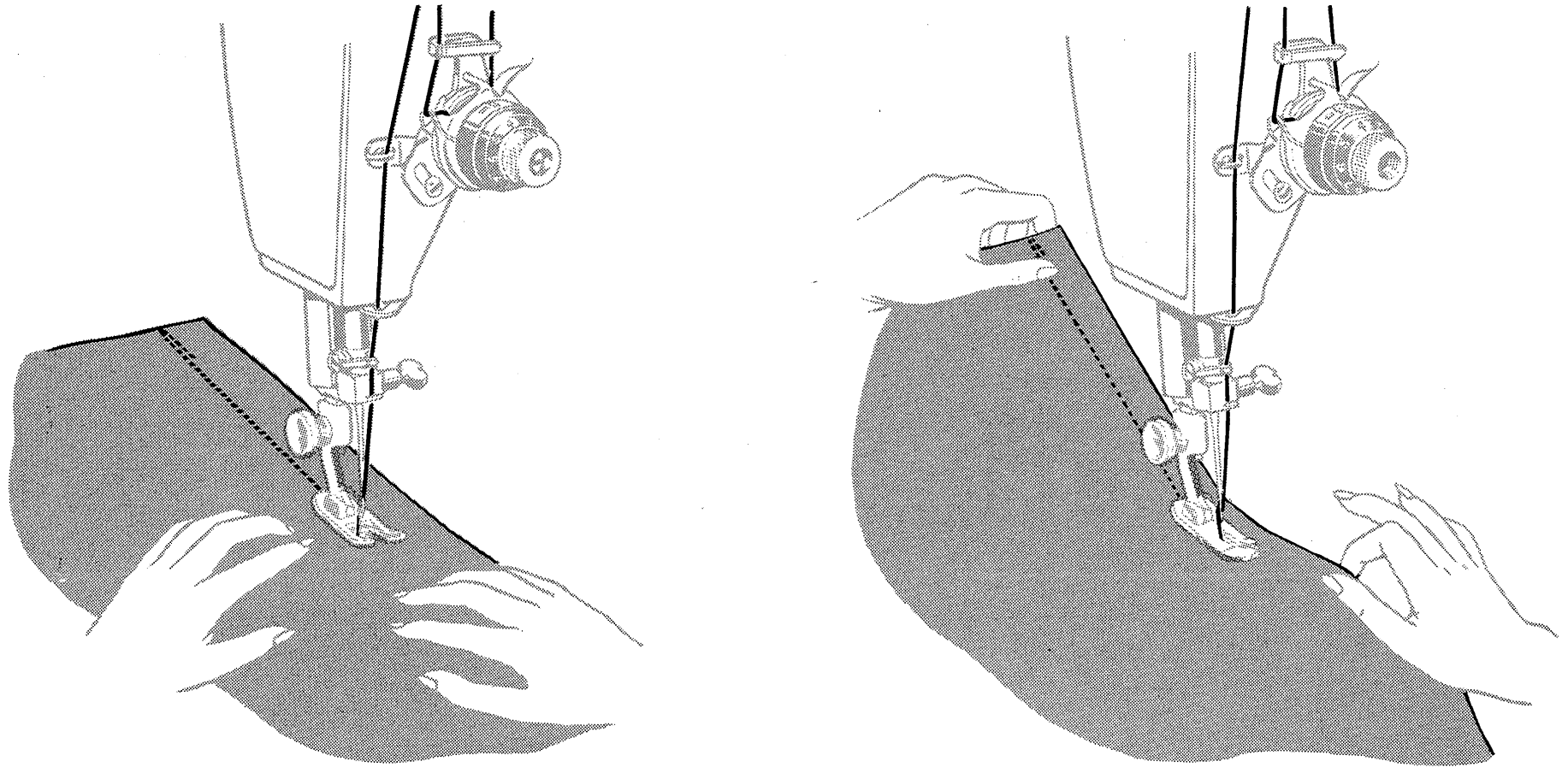
GUIDING AND SUPPORTING FABRIC

Most fabrics need only to be guided in front of the presser foot.

Fabrics of unusual texture and weave, filmy sheers, crepes, knits, tricots, etc., require support while being stitched.

For such fabrics, use the straight stitch throat plate and presser foot, and provide gentle tension on the seam by holding both in front and in back of the presser foot as illustrated.

PRESSURE ADJUSTMENTS

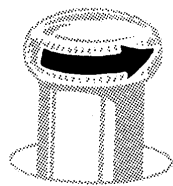
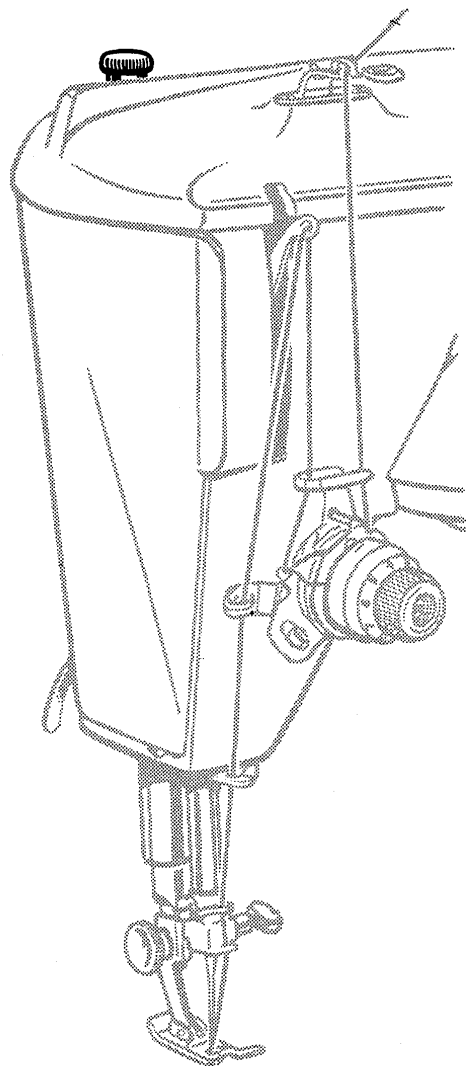

Decrease

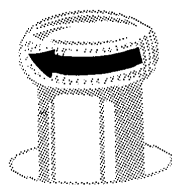

Increase

To decrease pressure, turn thumb screw upward.
To increase pressure, turn screw downward.

Pressure is the force the presser foot exerts on fabric while it is being stitched.

Smooth, even handling of several thicknesses of fabric results when pressure is correctly regulated.

Too light a pressure will result in irregular feeding which affects both quality of stitch and evenness of seams.

Too heavy a pressure not only affects stitch and seam quality but will mar smooth surfaces and pile fabrics.

Surface finish, as well as the weight and texture of the fabric, must be considered in determining the amount of pressure needed.

NEEDLE THREAD TENSION STRAIGHT STITCHING

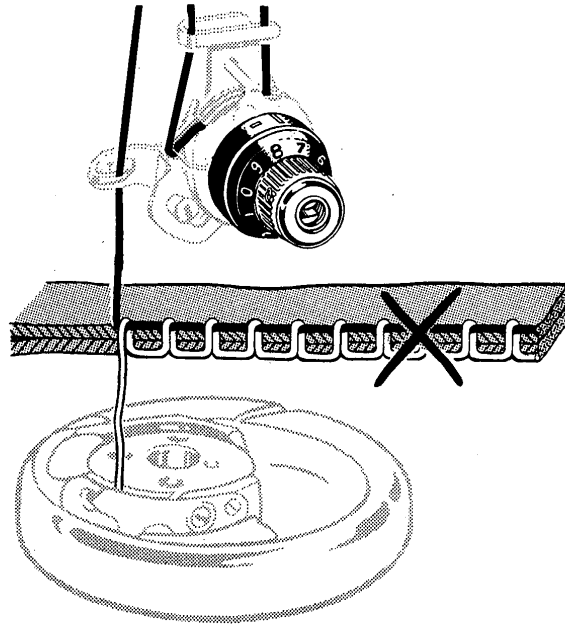

Needle thread tension too tight — correct by setting dial to lower number.

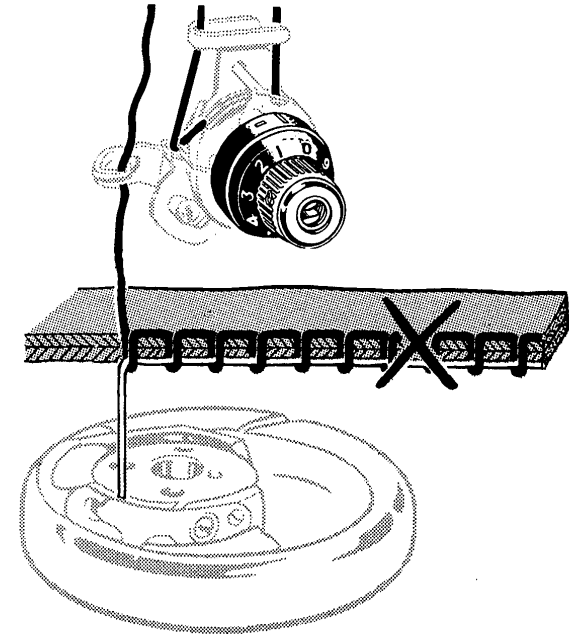
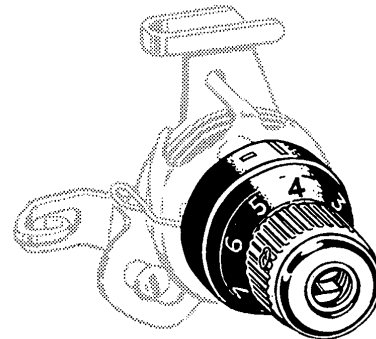

Needle thread tension too loose — correct by setting dial to higher number.

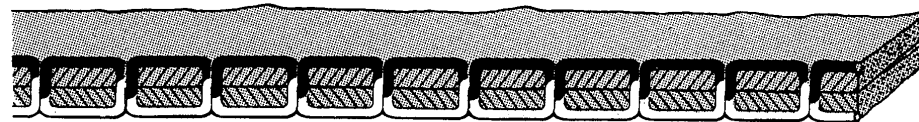

A perfectly locked stitch results with upper and lower tensions balanced so that needle and bobbin threads are drawn equally into fabric.

BOBBIN THREAD TENSION STRAIGHT STITCHING

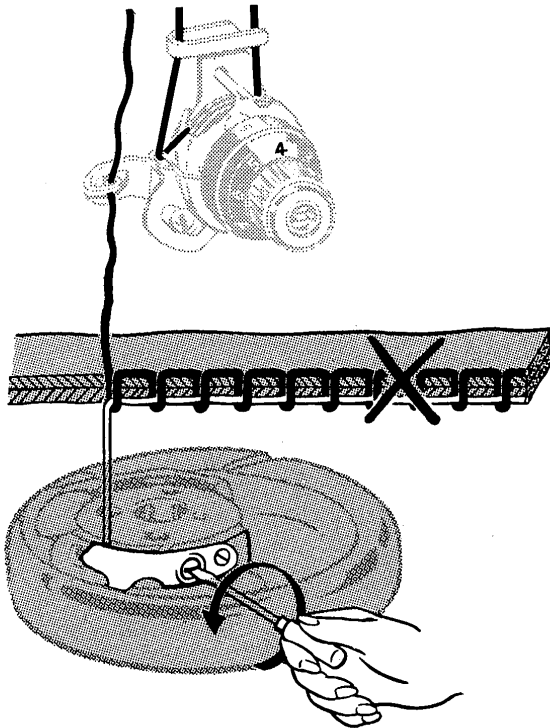

Bobbin thread tension too tight—correct by turning screw counterclockwise.

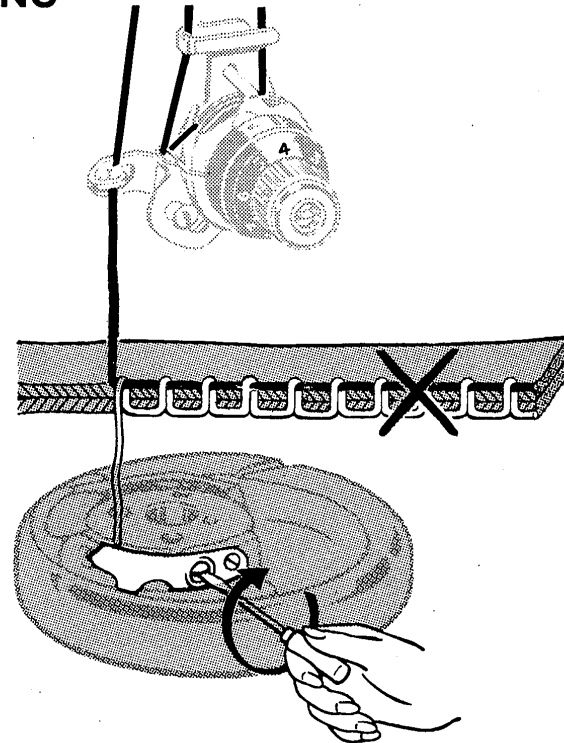

Bobbin thread tension too loose—correct by turning screw clockwise.

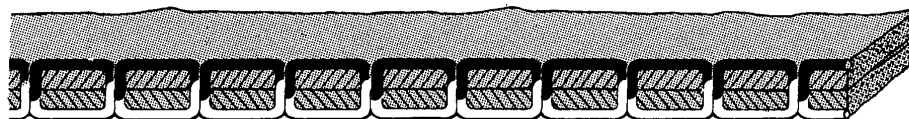

A perfectly locked stitch results with the upper and lower tensions balanced so that needle and bobbin threads are drawn equally into fabric.

ZIGZAG STITCHING EQUIPMENT

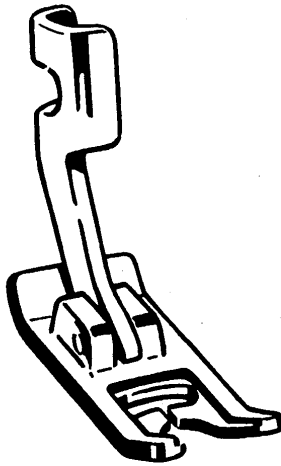

GENERAL PURPOSE
PRESSER FOOT.

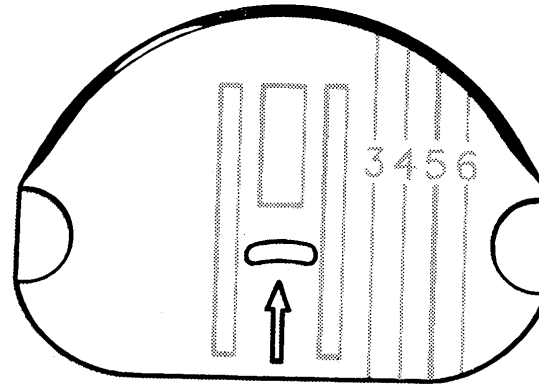

GENERAL PURPOSE THROAT PLATE.

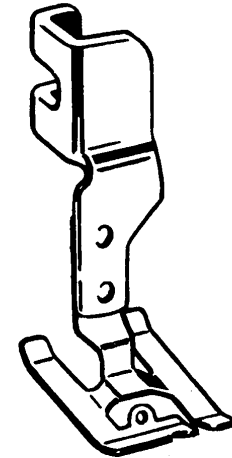

SPECIAL PURPOSE
PRESSER FOOT.

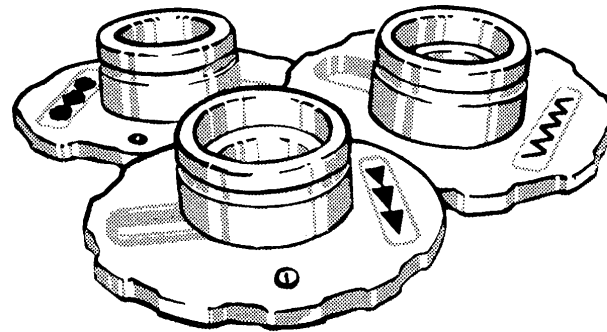

FASHION DISCS

ZIGZAG STITCHING

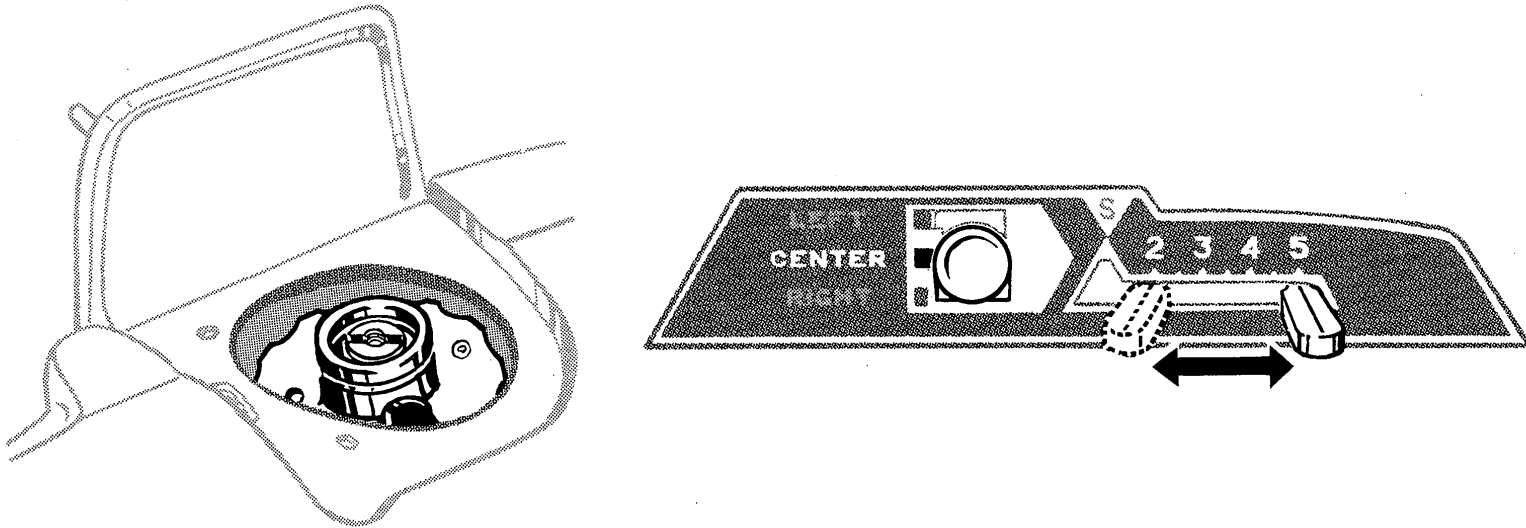

FASHION DISCS CONTROL STITCH PATTERNS.

NEEDLE POSITION LOCATES STITCHING AT LEFT, CENTER OR RIGHT.

WIDTH LEVER CONTROLS WIDTH OF STITCH PATTERN.

STITCH REGULATOR CONTROLS LENGTH OF STITCH.

Nine removable FASHION Discs are furnished with the machine. The Zigzag Disc ① is supplied on the disc holder in the machine. Eight additional discs are in the attachment set. Each disc produces an individual design, and is interchangeable with the Zigzag Disc.

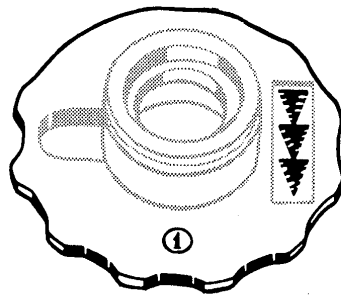
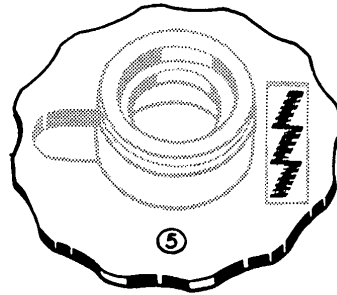
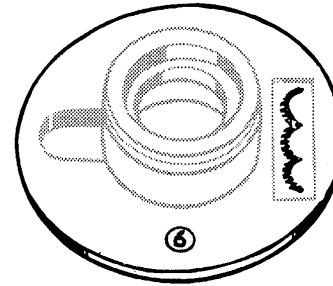
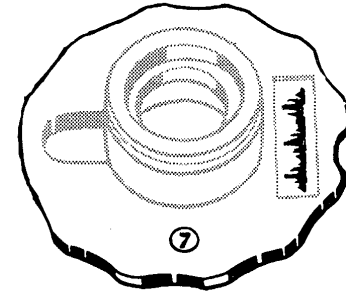
FASHION DISCS**ARROWHEAD****BANNER****CRESCENT****ICICLE**

These four interchangeable FASHION Discs plus the four illustrated on the next page, are included with the machine.

See **page 32** for removal and replacement.

FASHION DISCS

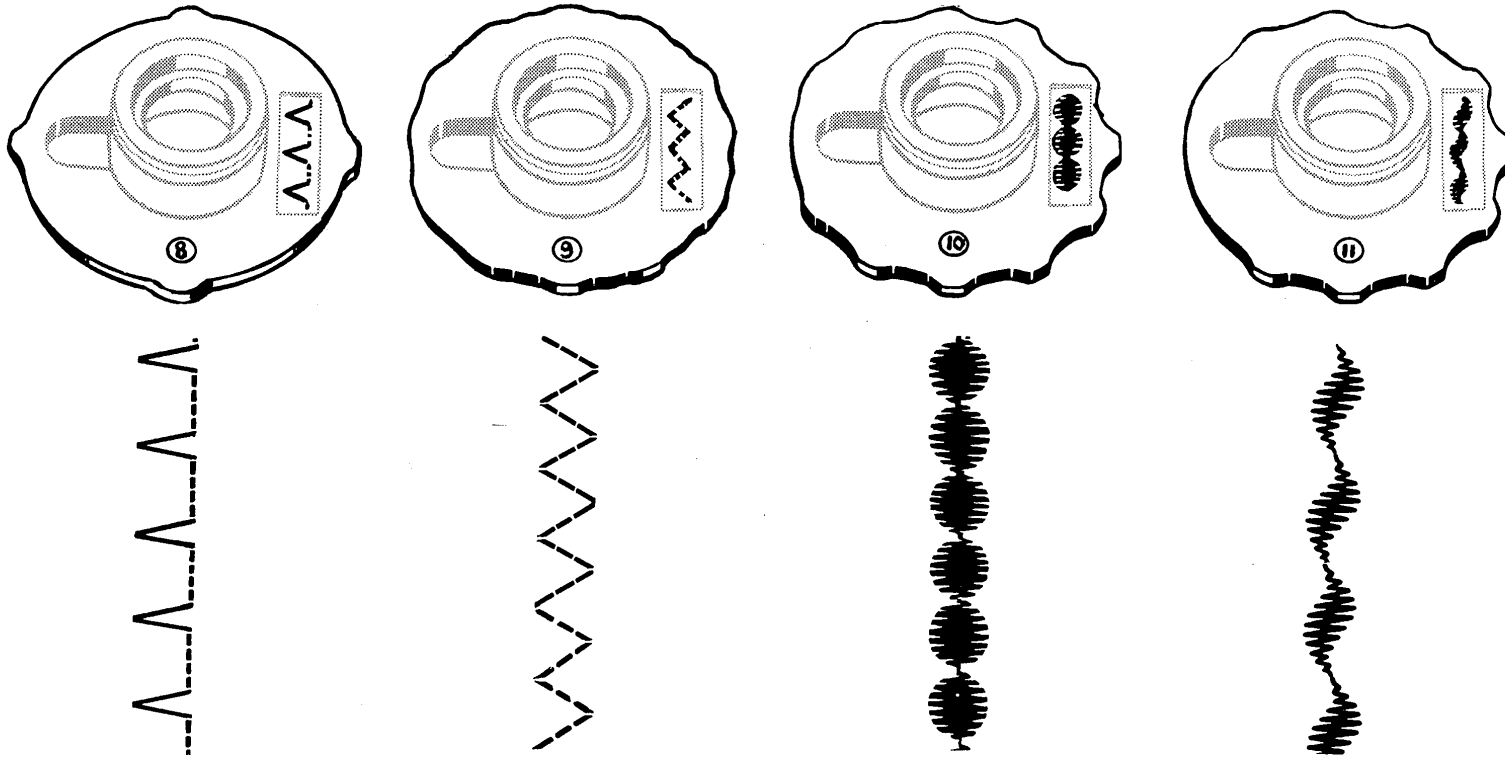

BLIND STITCH

MULTI-STITCH

BALL STITCH

RIBBON STITCH

These four interchangeable FASHION Discs, plus the four illustrated on the previous page, are included with the machine.

See **page 32** for removal and replacement.

REMOVAL AND REPLACEMENT OF FASHION DISCS

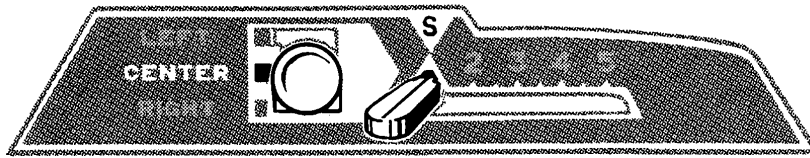

BIGHT CONTROL: S

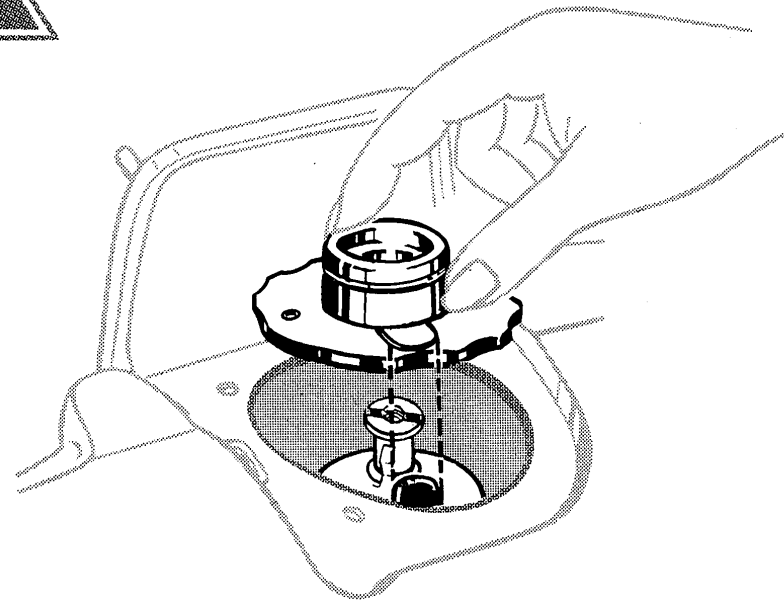

To replace FASHION Discs, set Bight Lever at S. Raise disc cover at top of machine. Remove disc by pulling upward, place another disc on the spindle, and push downward until the disc snaps into place. Set Needle Position Control and Bight Lever at desired setting.

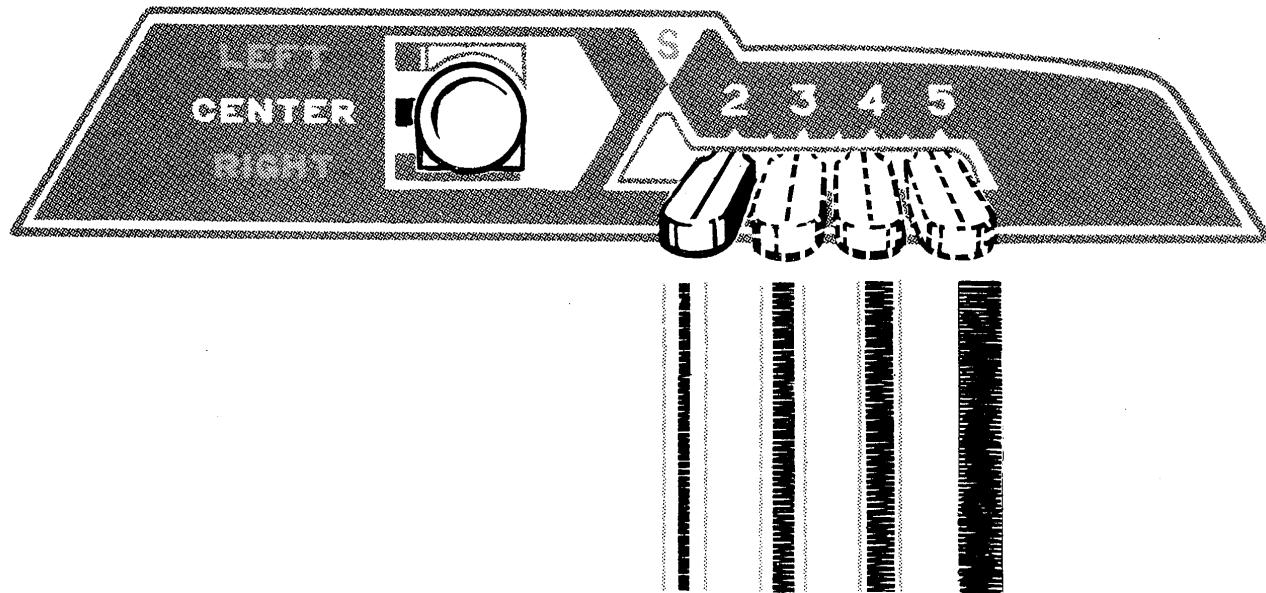
CONTROL OF WIDTH**ZIGZAG STITCHING**

The width of the zigzag stitch is controlled by the Bight Lever. As the lever is moved to the right, the width of the zigzag stitch is increased. Settings of 2 through 5 are indicated, but intermediate settings may also be used.

Do not make any Bight Lever adjustments while the needle is in the fabric.

NEEDLE POSITIONS FOR ZIGZAG STITCHING

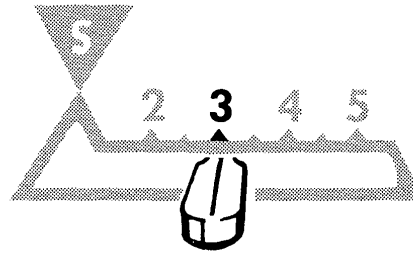

A needle position setting of **CENTER** places stitching in central needle position. Settings **LEFT** or **RIGHT** place stitching in left or right needle positions at widths less than 5.

CENTER needle position is preferred. **LEFT** or **RIGHT** settings are only used when special placement of stitching is desired . . . for example: buttonholes, button sewing, blind stitching.

Do not make any needle position adjustments while the needle is in the fabric.

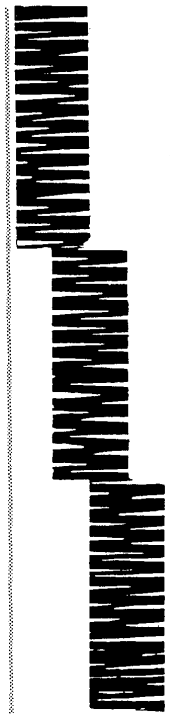
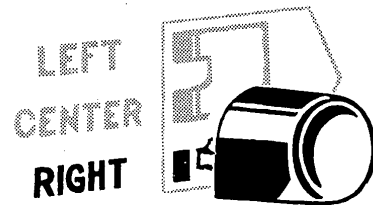
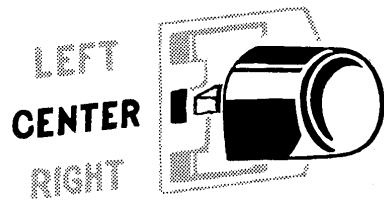
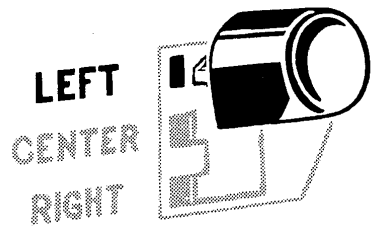

STITCH LENGTH ADJUSTMENT FOR SATIN STITCHING

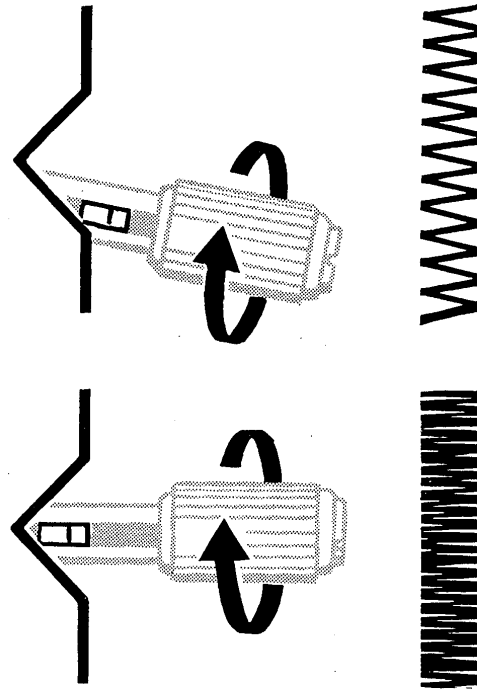
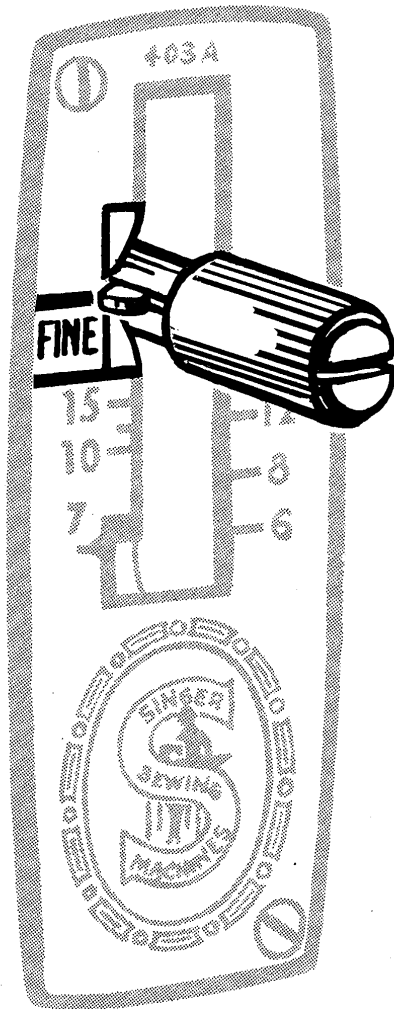

The "fine" area of the stitch regulator with its inclined surface provides a means of gradually shortening the stitch length.

As the knob is turned, the pointer rides up the incline until a closed satin stitch is obtained.

The exact stitch setting will vary with the texture of the fabric. It is advisable to make a test on a scrap of self-fabric, using the Special Purpose Foot, before proceeding with the actual work.

SATIN STITCH TENSION ADJUSTMENT

Satin stitching requires a lighter needle thread tension than straight stitching or open designs. The wider the satin stitching the lighter the tension required.

Wide satin stitching, Bight Lever at 5, requires the least amount of tension. For narrower satin stitching slightly more tension should be used.

To determine correct tension setting, a test sample should be made on self-fabric using the Special Purpose Foot. A properly balanced satin stitch should lie flat across the material. Any tautness or puckering will indicate too high a needle thread tension.

Some soft fabrics may require the addition of a backing to insure good stitching results. Crisp organdy and lawn are suitable for this purpose.

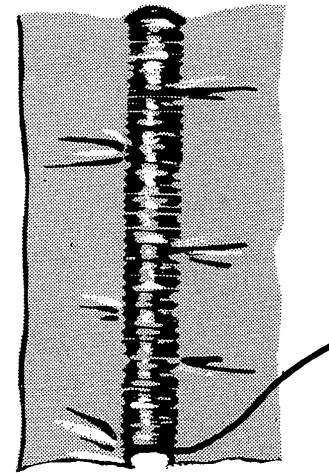
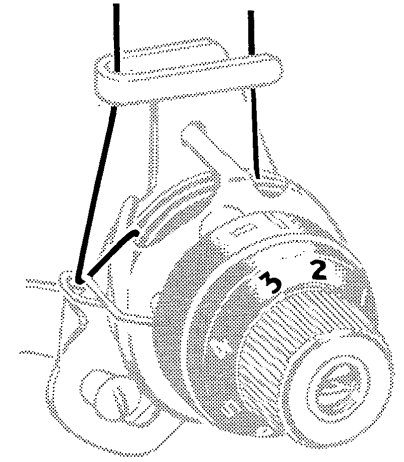
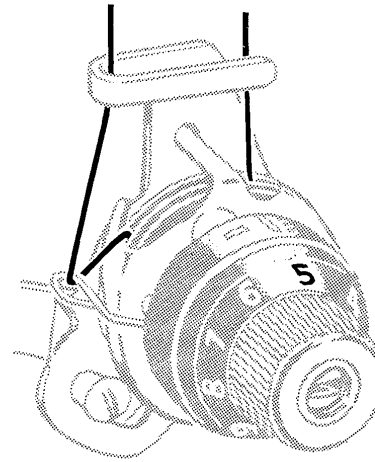

Tight needle thread
tension

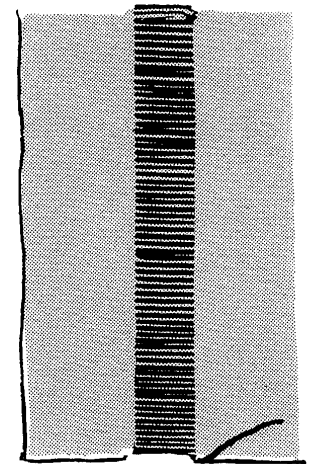

Correct needle thread
tension

TWO NEEDLES

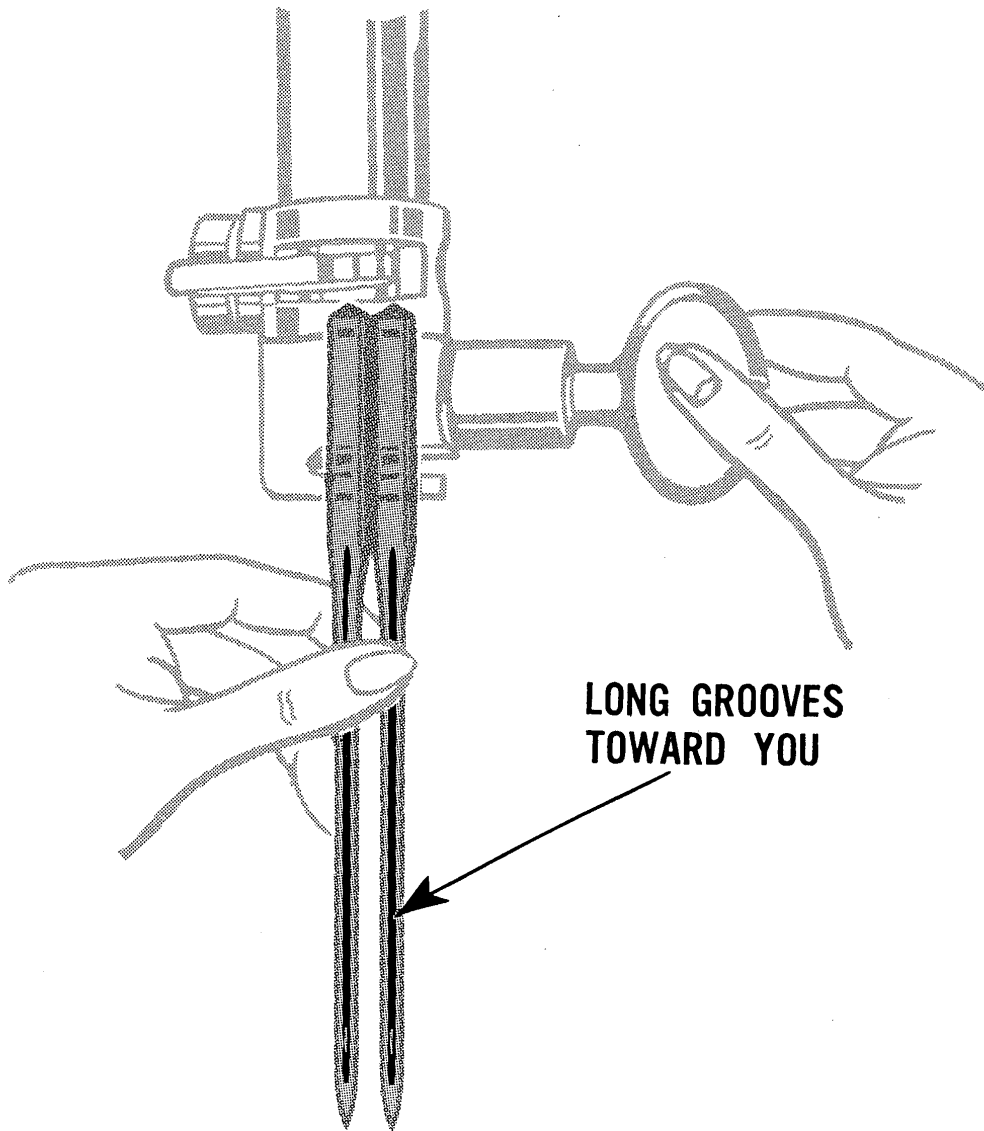

The needle clamp accommodates two 15 x 1 needles, generally of the same size. However, where special effects are desired, needles of different sizes may be used together, with corresponding threads. Loosen the thumb screw and insert the additional needle from the right. (See **page 6** for procedure.)

TWO NEEDLES UPPER THREADING

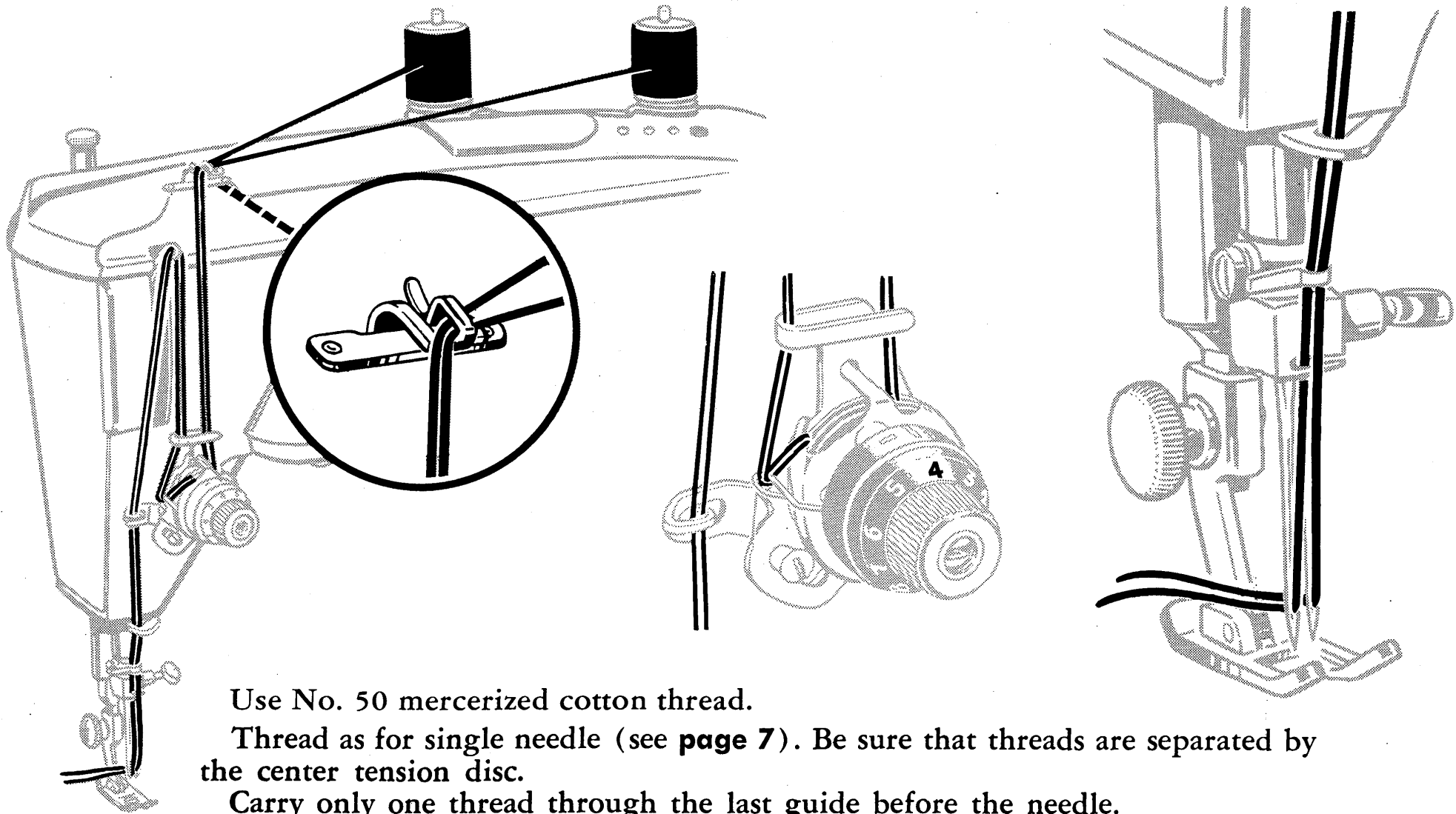

Use No. 50 mercerized cotton thread.

Thread as for single needle (see **page 7**). Be sure that threads are separated by the center tension disc.

Carry only one thread through the last guide before the needle.

TWO NEEDLES STRAIGHT STITCHING

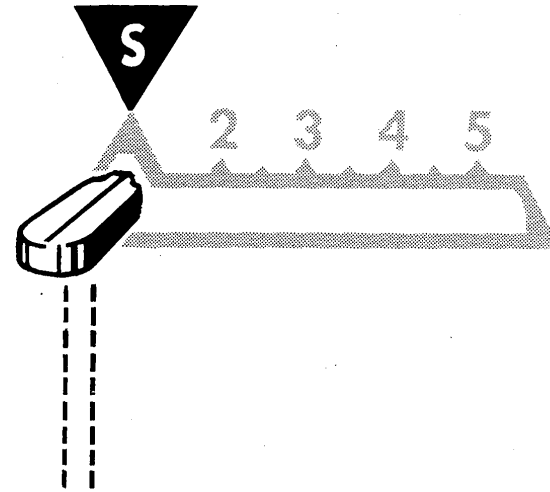
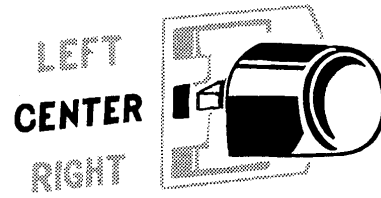
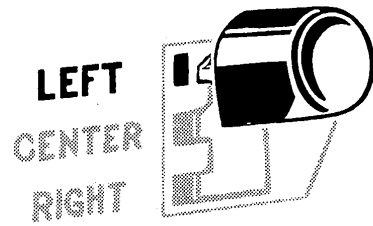

BIGHT CONTROL: S

NEEDLE POSITION: LEFT OR CENTER ONLY

GENERAL PURPOSE THROAT PLATE AND PRESSER FOOT

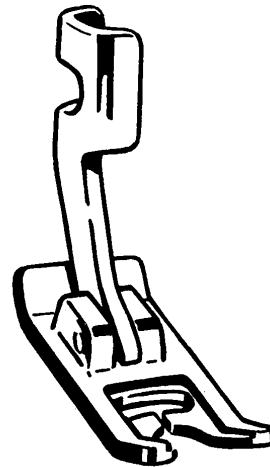
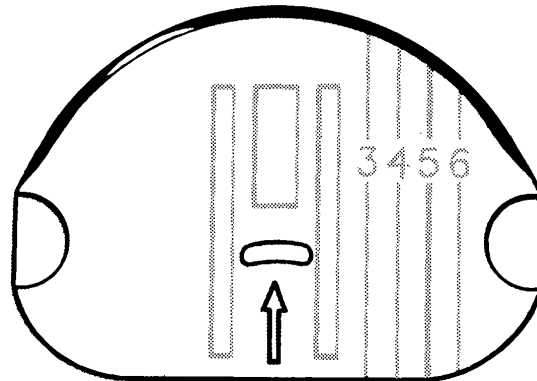

TWO NEEDLES ZIGZAG AND DECORATIVE STITCHING

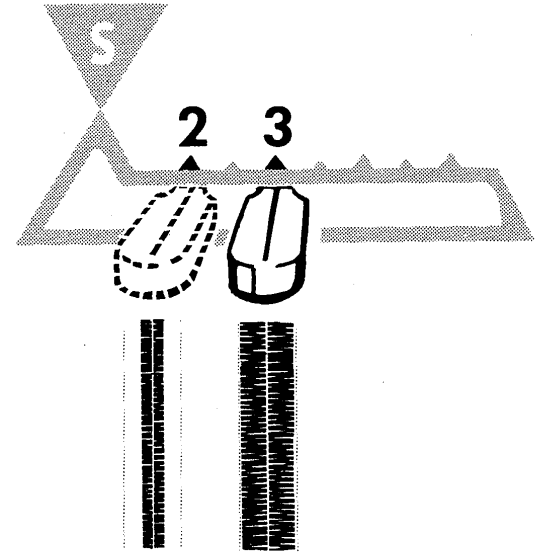
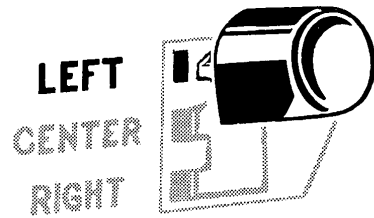

BIGHT CONTROL: 2 OR 3 MAXIMUM
NEEDLE POSITION: LEFT ONLY
GENERAL PURPOSE THROAT PLATE
GENERAL PURPOSE PRESSER FOOT
OR SPECIAL PURPOSE PRESSER FOOT

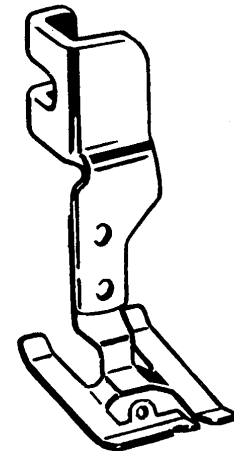
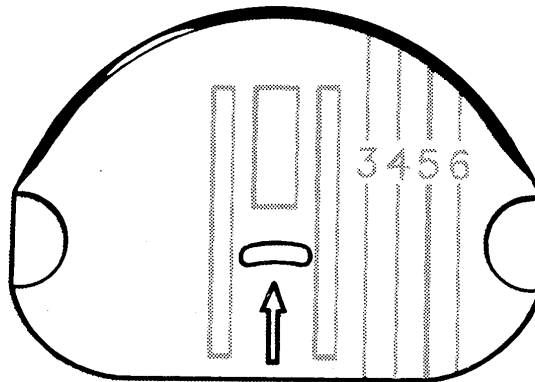
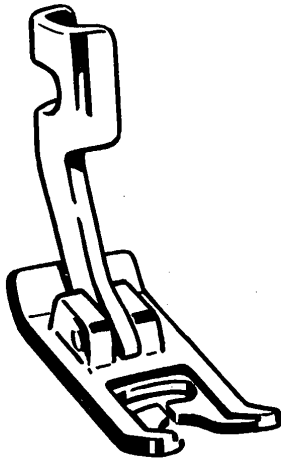

DECORATIVE TWO NEEDLE STITCHING



BANNER.....  ⑤



CRESCENT.....  ⑥



ICICLE.....  ⑦



BLIND STITCH.....  ⑧



MULTI-STITCH.....  ⑨

SPECIAL PURPOSE FOOT

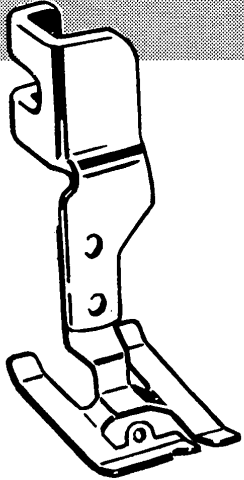

This light, flexible foot is designed for satin stitching. It provides maximum visibility and maneuverability, while allowing closely spaced zigzag stitches to feed freely.

It is ideal for accurate placement of satin stitching in buttonholes, monograms, motifs and applique work.

The eyelet on the left side of the foot accommodates a filler cord.

APPLICATIONS

Buttonholes
 Applique
 Monograms

Decorative Stitching
 Couching
 Motifs

BUTTONHOLES

FASHION DISC: ZIGZAG ①
 BIGHT CONTROL: SEE BELOW
 NEEDLE POSITION: LEFT
 THROAT PLATE: GENERAL PURPOSE
 SPECIAL PURPOSE FOOT
 STITCH LENGTH: FINE

To establish the correct stitch setting and length of buttonhole, a sample must first be made.

Three Bight Lever settings are suggested. Fabric weight will determine the selection.

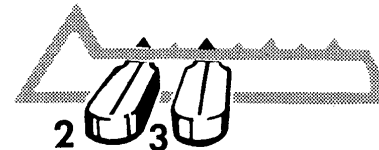
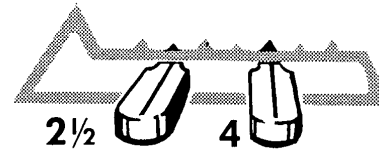
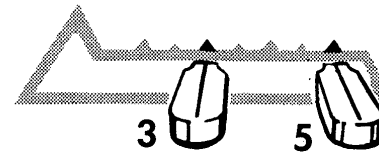

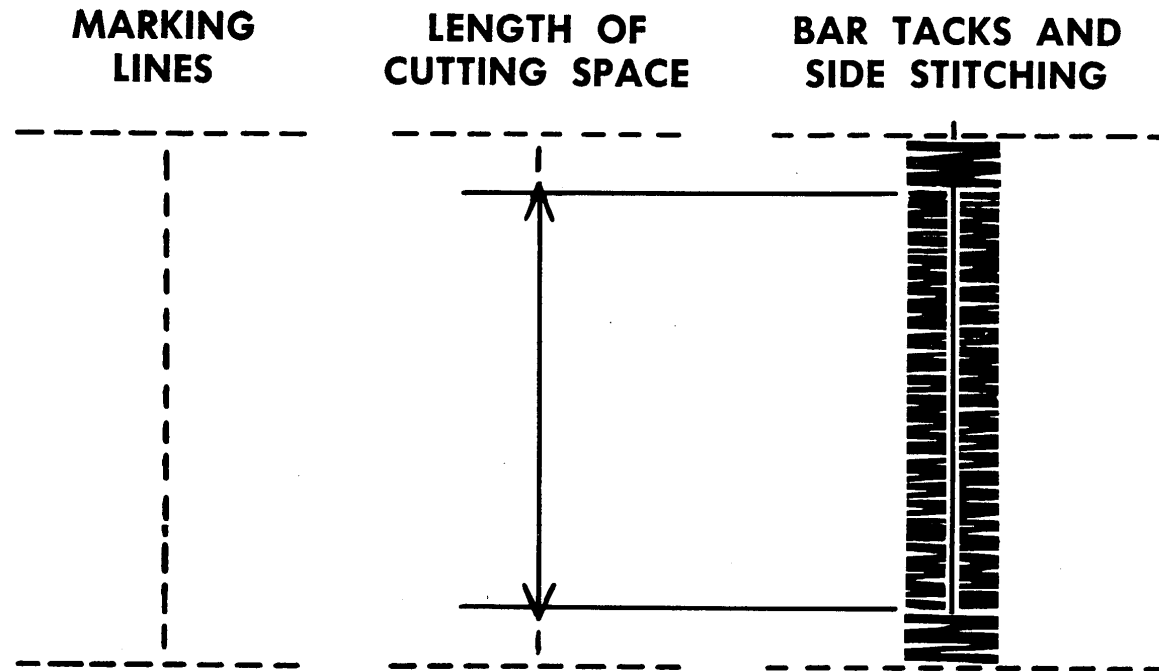
BUTTONHOLES

The length of cutting space, the opening through which the button passes, is measured by the width and thickness of the button.

The length of the finished buttonhole will be the cutting space plus $\frac{1}{8}$ inch for bar tacks.

Work a sample buttonhole in the same fabric as the garment. Use a double fold, duplicating a facing, and include interfacing if this has been used.

BUTTONHOLES

Procedure. Set needle control in LEFT position, and Bight Lever at setting desired for side stitching (see page 42). Place work under needle, aligning center marking of buttonhole with center score line of Special Purpose Foot.

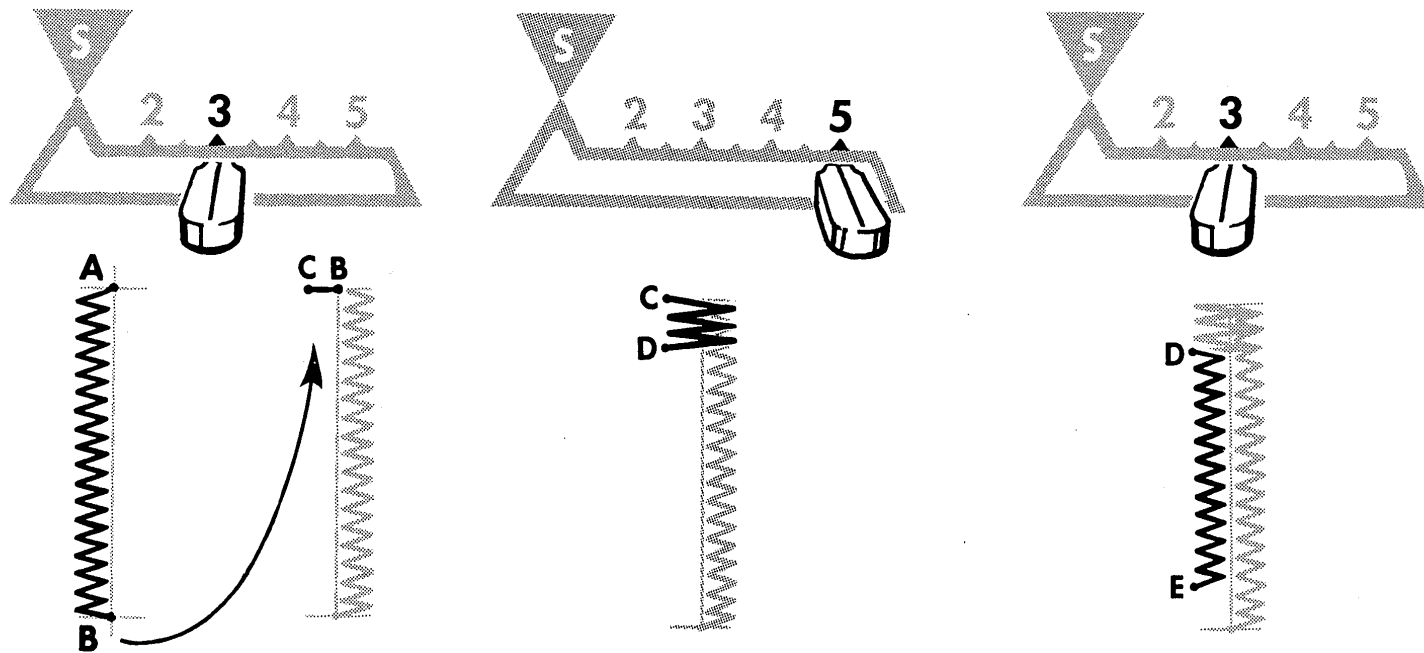

Side Stitching. Turn hand wheel toward you so that needle enters fabric at point A. Lower foot and stitch to end of marking. Leave needle in fabric at point B. Raise foot and pivot work on needle. Lower foot, and take one more stitch without changing Bight Lever setting, bringing work to point C.

Bar Tack. Adjust to bight lever setting for bar tacks and take no less than six stitches to complete tack. Stop at point D.

Side Stitching. Move to Bight Lever setting previously used for side stitching, complete work to point E. Point E is approximately six stitches from end of buttonhole.

BUTTONHOLES

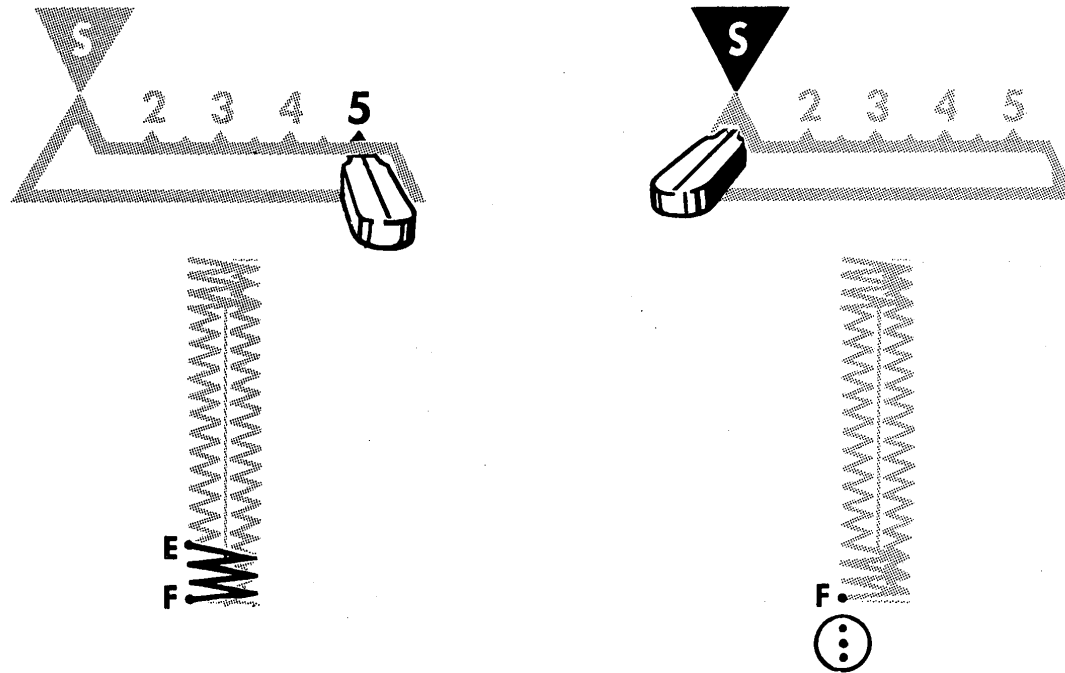

Final Bar Tack. Move to Bight Lever setting for bar tacks, and duplicate tack previously made, end at point F.

Fastening Stitch. To secure stitching, move Bight Lever to S setting and take three stitches.

Remove work, draw threads to the underside, fasten and trim. Cut opening for button with sharp embroidery scissors.

RAISED OR CORDED BUTTONHOLES

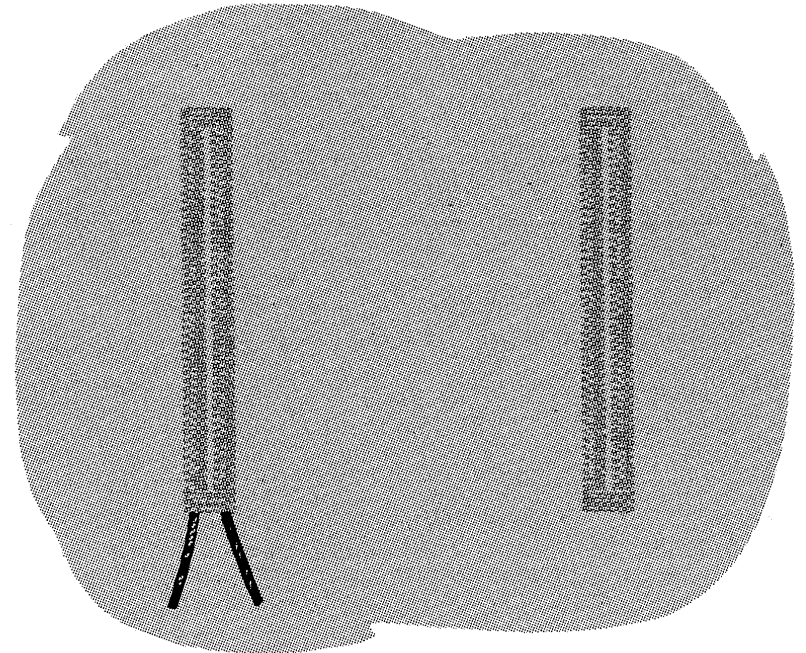
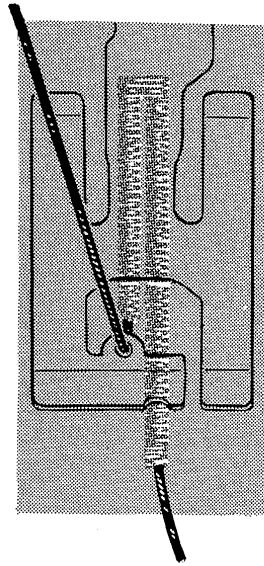
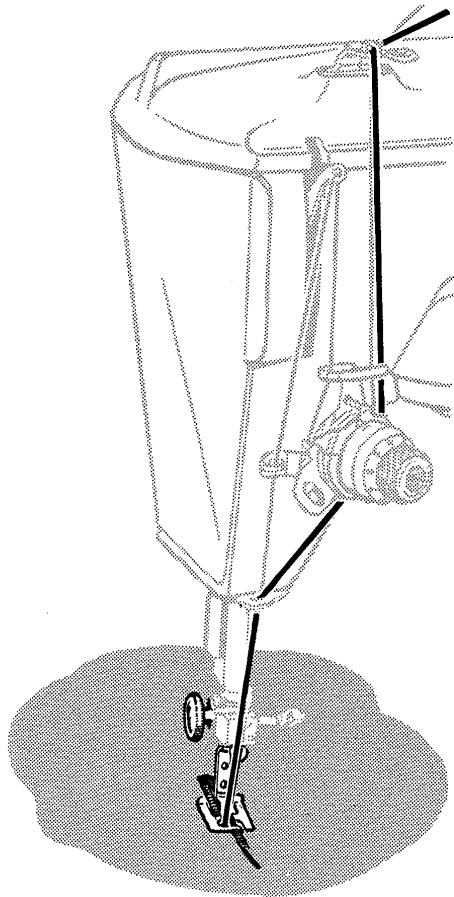

Both #8 pearl cotton and buttonhole twist make suitable filler cords for raised buttonholes.

Place the spool of filler cord on the second spool pin. Carry the cord through the first thread guide, straight down between the center and back tension discs, into the large thread guide and then through the eyelet on the Special Purpose Foot. Draw the cord under and in back of the foot and proceed as for regular buttonholes.

APPLIQUE

Applique adds beauty and interest to wearing apparel, linens and fabric furnishings.

Either contrasting or self-fabric may be used effectively. The most versatile stitch in appliqueing is a closely set zigzag stitch (FASHION Disc ©). The width of this stitch may be varied to accommodate weaves and textures of fabrics.

Many of the FASHION Disc patterns present interesting ways to applique with decorative stitching.

Preparation. There are two methods by which applique work may be done. The appropriate method is determined by the fabric being used, and a test sample is advisable.

Position the design properly and baste it to the fabric. Attach the Special Purpose Foot to the presser bar.

Method #1. Insert FASHION Disc for the desired stitch pattern (FASHION Disc © for zigzag stitch). Set Bight Lever for the desired width of stitch. Following the shape of the design, outline it entirely with applique stitching. Any excess fabric on the outer edges is trimmed away after the stitching has been completed.

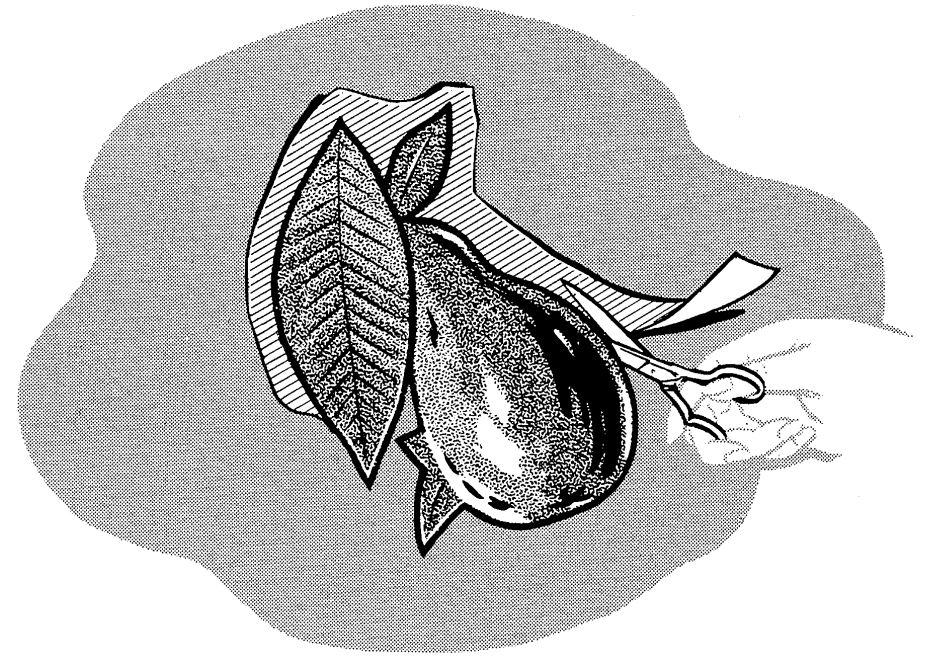

APPLIQUE

Method #2. Set Needle Position Control at CENTER and Bight Lever at S for straight stitching. Outline the entire design with a short stitch. Trim the raw edges down to the stitching.

Select and insert the desired stitch pattern, set Bight Lever at desired width of stitch, and over-edge the design with this stitching. A smooth, lustrous finish results, which requires no additional trimming.

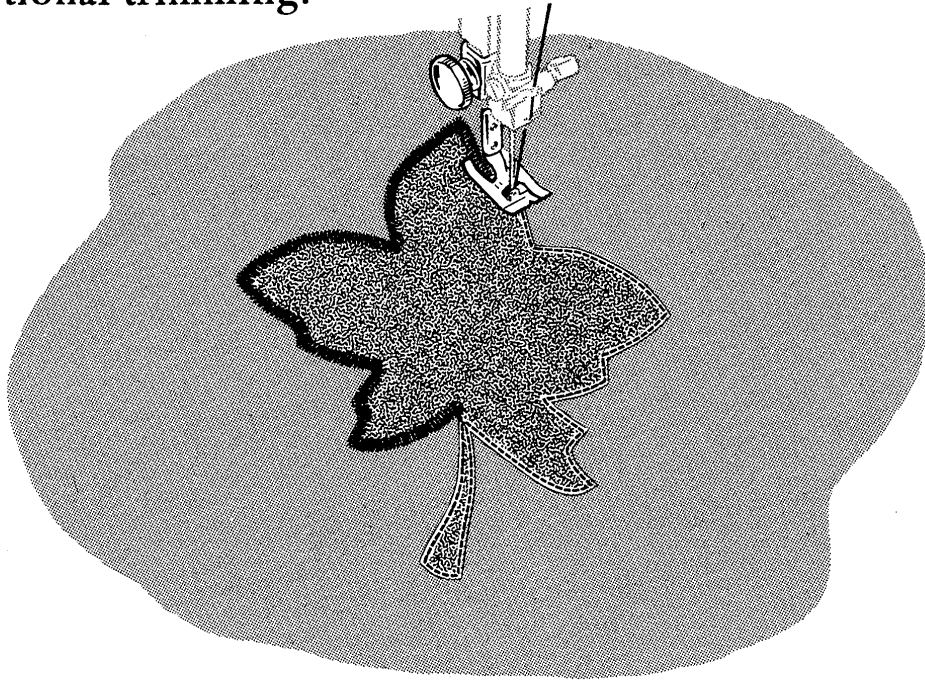

Corded Applique. The Special Purpose Foot, which provides for a filler cord, is perfect for corded applique work. Gimp, crochet thread or buttonhole twist are generally used.

See **page 46** for threading.

Either method of appliqueing may be used when cording is desired. The only change in procedure is the introduction of the cord, over which the applique stitching is formed.

This stitching technique results in a raised, dimensional effect, and is an ideal finish for lace applique.

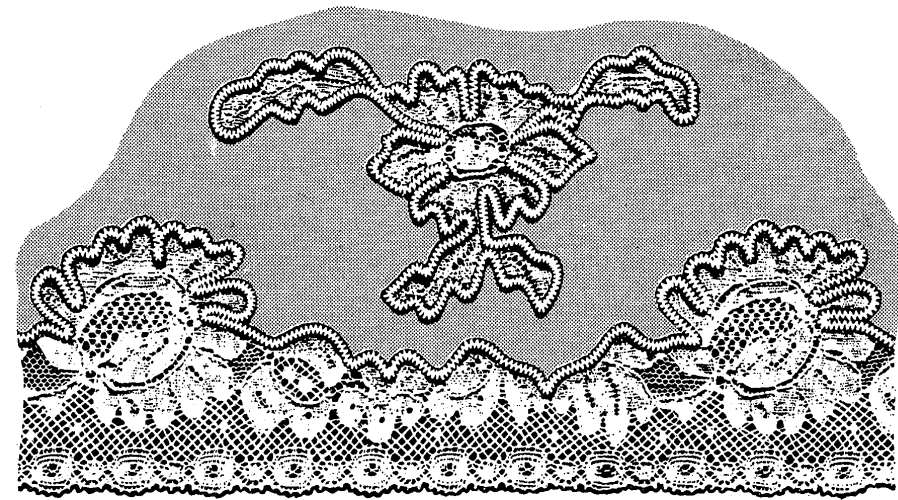

MONOGRAMS AND MOTIFS

Many of the decorative stitch patterns lend themselves perfectly to the creation of attractive and unusual motifs and monograms.

Select a simple design from the many transfer patterns available, or sketch one to suit your purpose.

Position the design, and trace or transfer to the right side of the material.

When working a design on a single thickness of fabric, a backing is essential. Crisp lawn and organdy are suitable fabrics for this purpose, and may be trimmed away closely to the stitching when the work is completed.

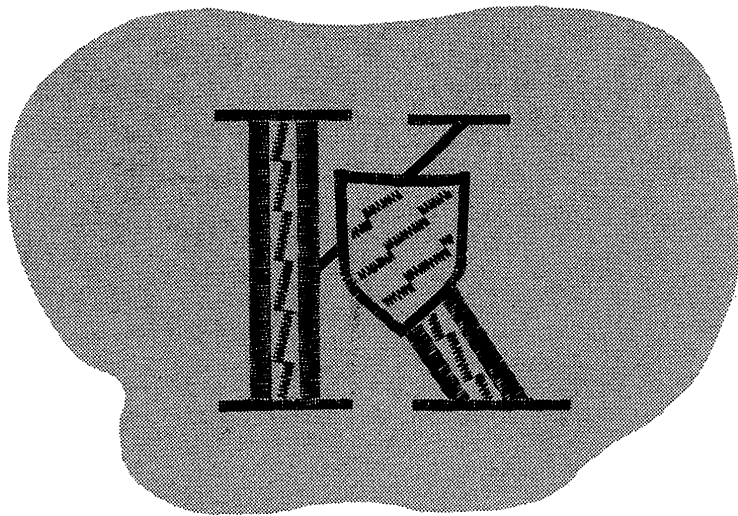

A test sample should always be made before proceeding with the actual work to determine stitch setting and spacing. Use the Special Purpose Foot, especially designed for accurate satin stitch placement.

To reproduce a specific portion of a stitch pattern, first stitch on a scrap of material until the desired point in the design is reached.

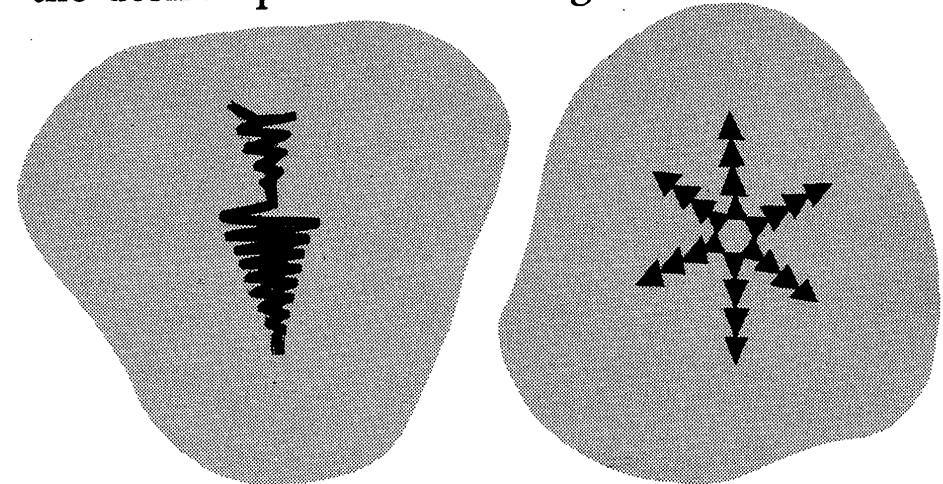



Remove the material from under the presser foot. Now position motif or monogram under the needle. Lower presser foot and stitch.

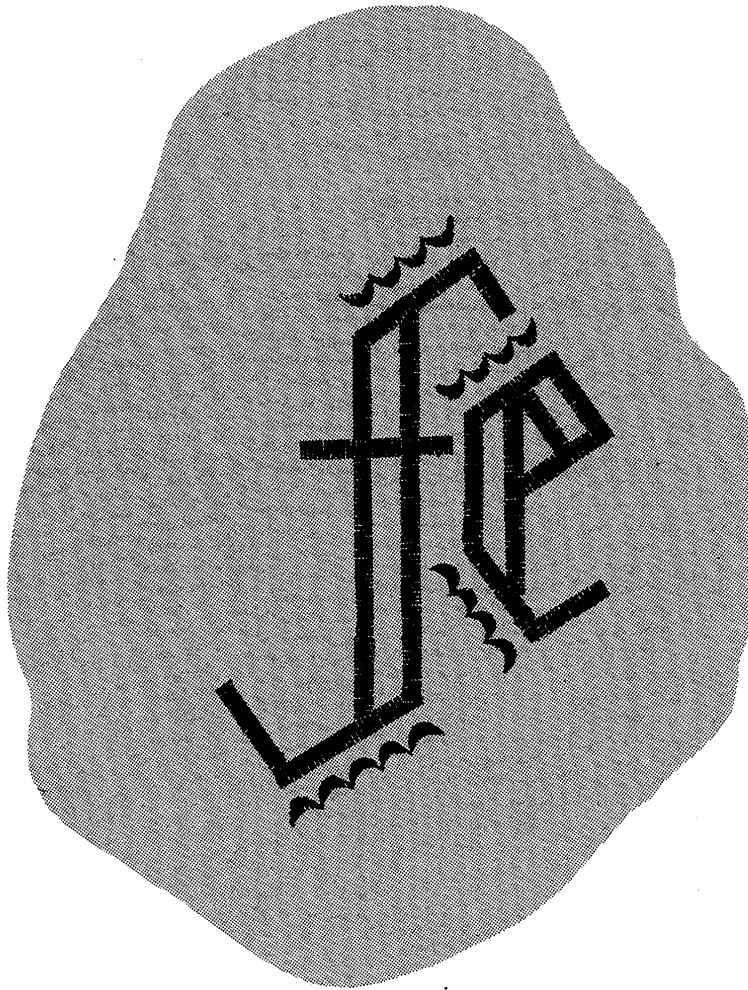

This procedure is recommended for all precise design placement. Individual leaves, and flower petals, for example, can be created in this way.

MONOGRAMS AND MOTIFS

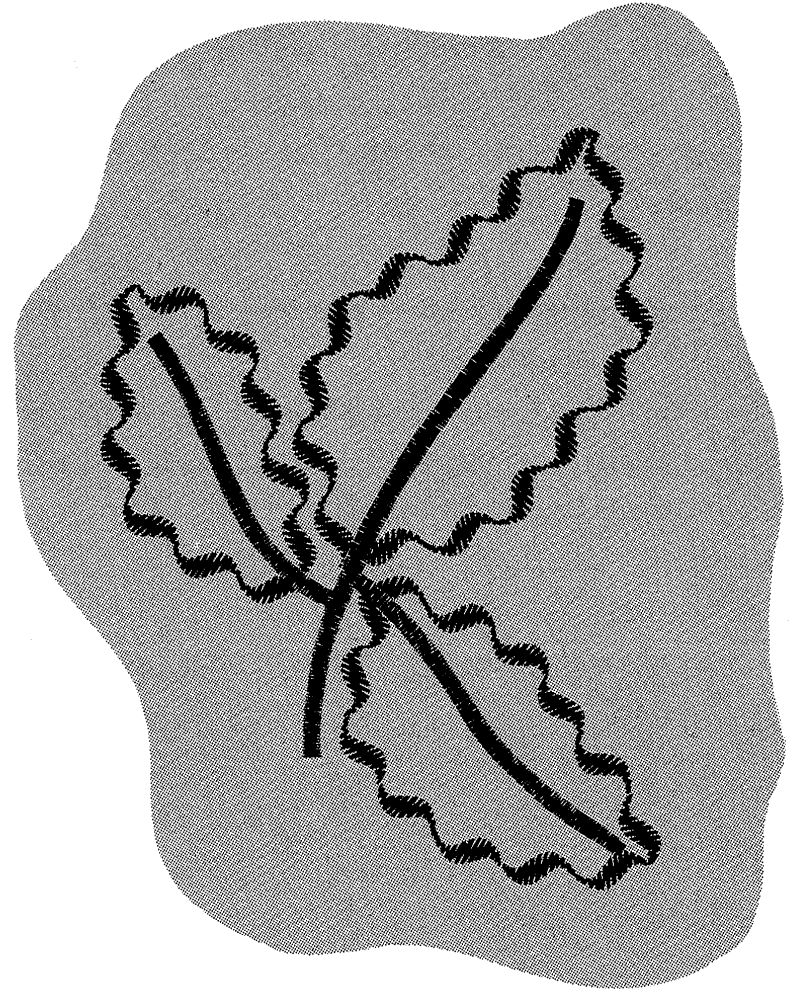

ZIGZAG  ①
CRESCENT  ⑥



ZIGZAG  ①
RIBBON  ⑪

BORDER DESIGNS

Border designs of unlimited variety can be created when several stitch patterns are used in combination. Simple or elaborate, delicate or bold, the width and density of the border can be varied according to the application.

In addition to the suitability of such stitching for linens, draperies, and apparel as border designs, it can be effectively used on plain fabrics to simulate stripes and plaids.

Bands of ribbon and lace, applied with stitch patterns, offer additional opportunities for unusual and dramatic treatments.

Before proceeding with the actual work, a test sample on self-fabric should be made.

Use the Special Purpose Foot. For soft or loosely woven fabrics, use a backing of crisp lawn or organdy.

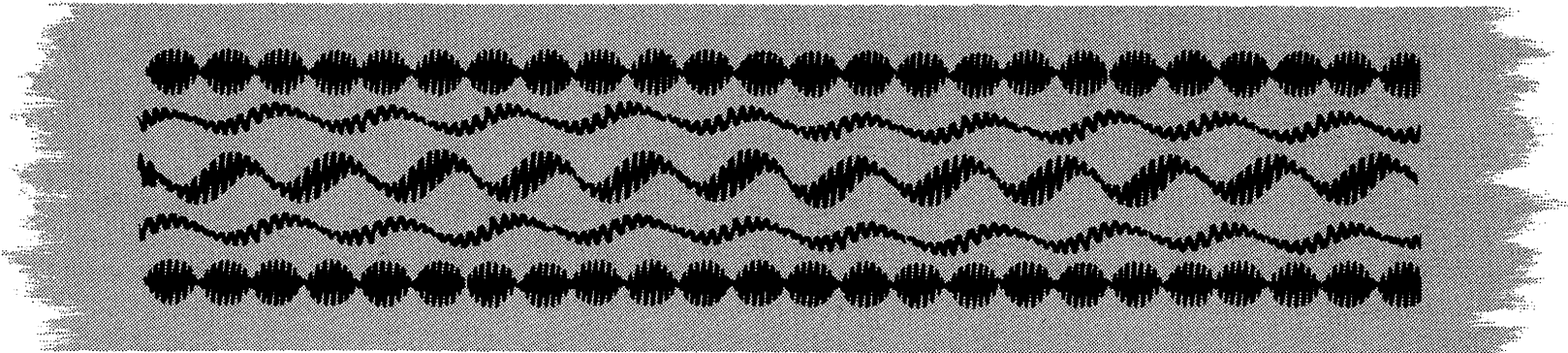

BALL  (10)

RIBBON  (11)

52
BORDER DESIGNS

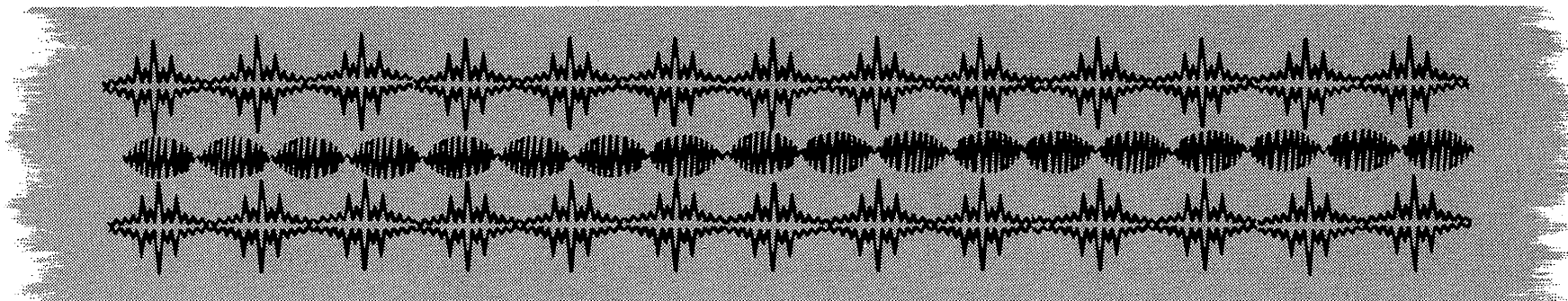

ICICLE.....  ⑦

BALL.....  ⑩

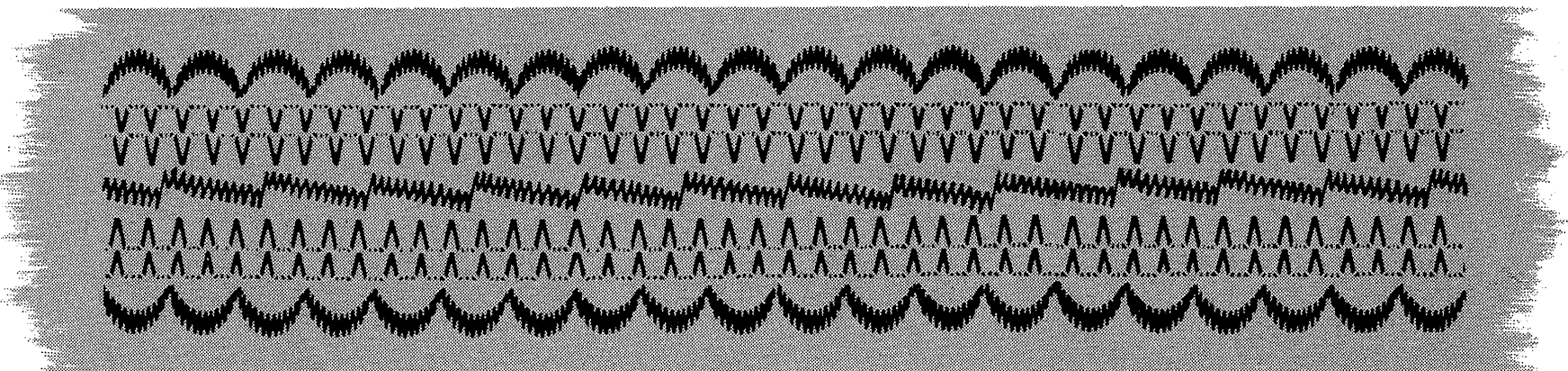

CRESCENT.....  ⑥

BLIND STITCH....  ⑧

BANNER.....  ⑤

SEAMING SHEERS

FASHION DISC: ZIGZAG ①

RIGHT CONTROL: 2

NEEDLE POSITION: CENTER

THROAT PLATE: GENERAL PURPOSE

SPECIAL PURPOSE FOOT

STITCH LENGTH: FINE (ABOVE 20)

A dainty hair-line finish is particularly desirable for the inside seams of sheer collars, facings and yokes. Seam allowances that ordinarily show through are eliminated.

Both heavy duty thread and tatting thread make suitable filler cords (see **page 46** for threading).

Follow the seam outline covering the cord. Cut away seam allowance close to line of stitching.

Turn and press.

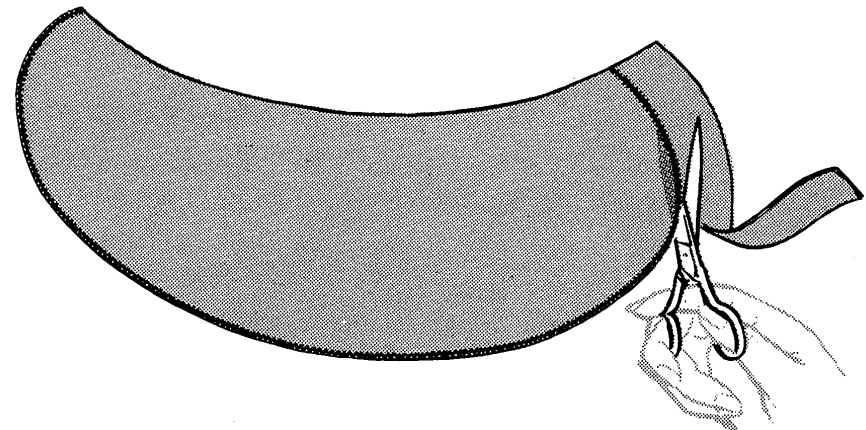
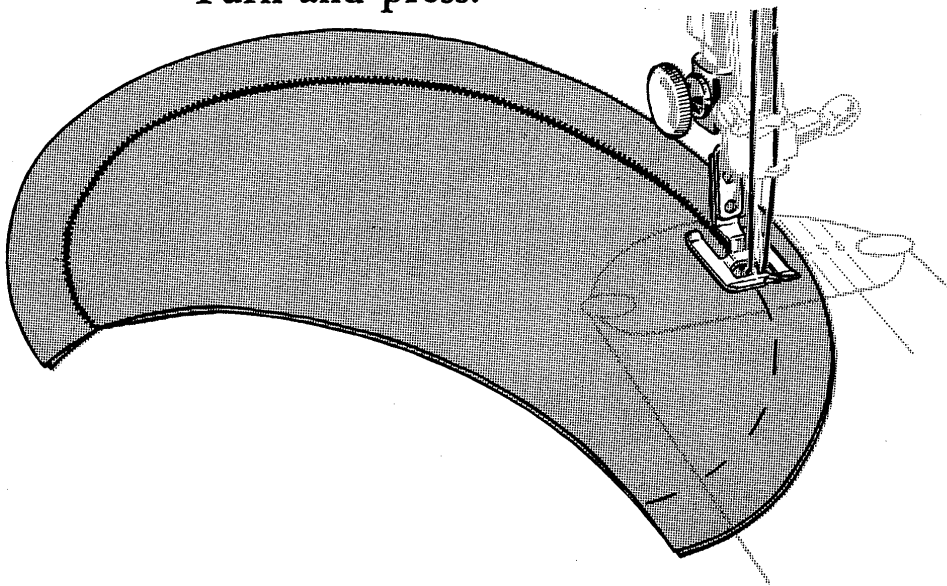

COUCHING

Novel effects are obtained by couching gimp, yarn or braid with stitch patterns.

Spaced patterns are the most appropriate as they allow the decorative cords to show as part of the design.

The Special Purpose Foot is ideally suited to this work.

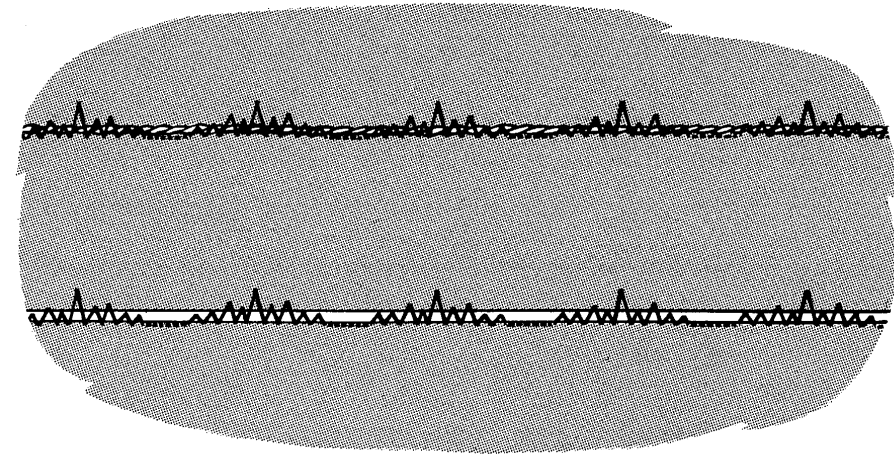

LACE EDGING AND INSERTION

Delicate and durable zigzag stitching is especially appropriate for the application of lace edgings and insertions.

Many decorative stitch patterns can be used effectively serving as both finish and trim.

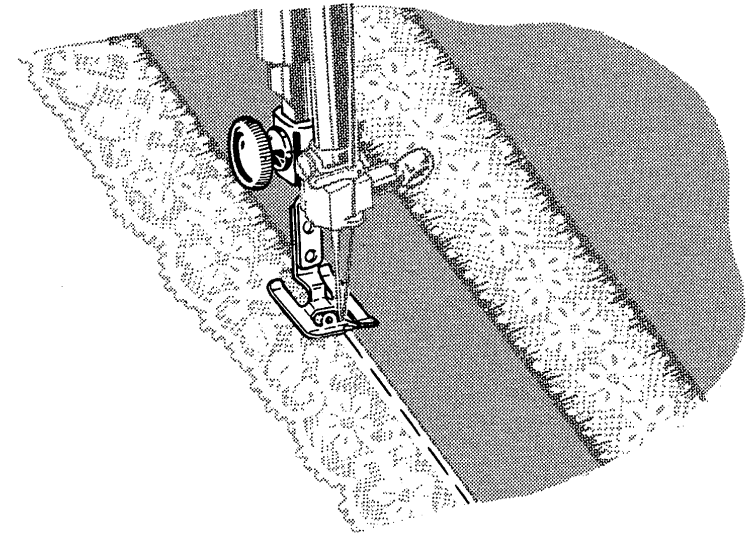

BUTTON SEWING FOOT

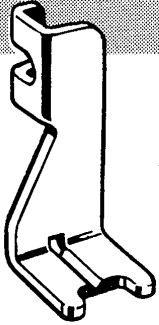

This short, open foot accommodates any size sew-through button, and holds it securely for stitching. The groove in the foot allows for insertion of a machine needle, over which a thread shank may be formed.

FASHION DISC: ZIGZAG 

BIGHT CONTROL: S AND 4

NEEDLE POSITION: LEFT

THROAT PLATE: RAISED

GENERAL PURPOSE

BUTTON SEWING FOOT

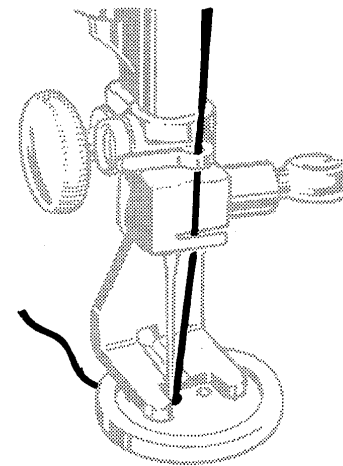
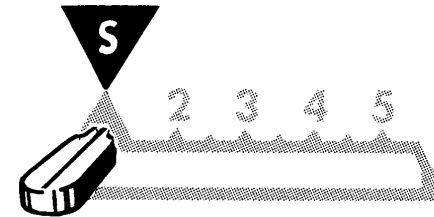

The space between the holes in the button determines the Bight Lever settings used. Settings "S" and 4 generally apply to standard buttons. The "S" setting is constant, but 4 can be increased or decreased to accommodate buttons with unusual spacing.

With FASHION Disc  in place, set Needle Position Control in LEFT position and Bight Lever at S. Raise throat plate. Position button under foot so that the needle will enter into left hole. Lower foot. Turn hand wheel toward you until needle rises out of fabric and is just above the foot.

BUTTON SEWING FOOT

Set Bight Lever at 4. The needle should then enter into the right hole in the button. Take approximately six zigzag stitches in this position. End on the left side.

To fasten stitching, adjust to S and take approximately three stitches.

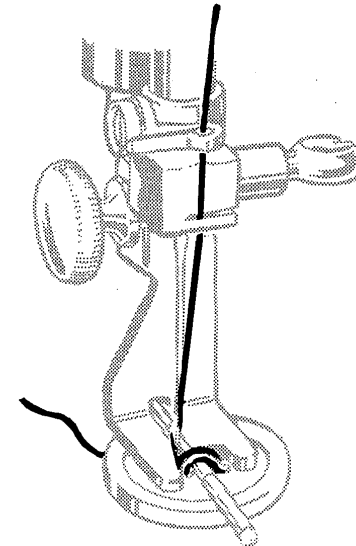
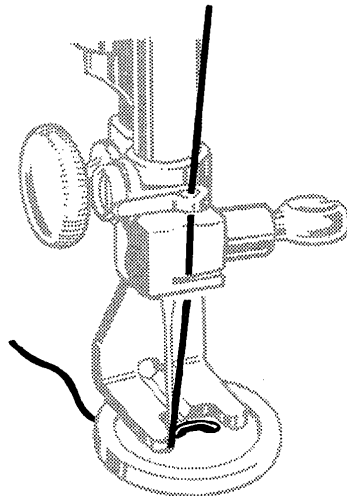
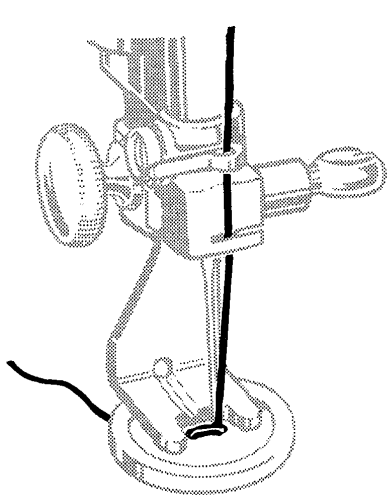
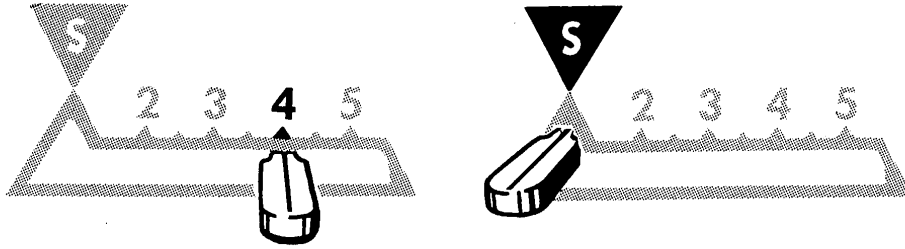

THREAD SHANK

In order to form a shank, stitching is done over a regular machine needle. Position button and lower button sewing foot. Place needle in the groove of the foot so the point enters the hole.

A larger shank results when the heavy end of the needle is utilized.

GENERAL PURPOSE FOOT

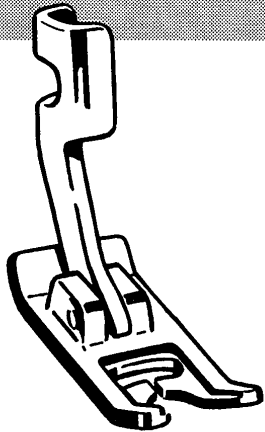

Used with the general purpose throat plate this foot provides a wide needle slot which accommodates all stitch settings and can be used for most sewing operations.

APPLICATIONS

Seams and Darts

Mending and Maintenance

Blind Stitched Hems

Seam Finishes

SEAMS

LINGERIE SEAMS

Dainty lingerie seams are made durable and rip-proof with zigzag stitching (FASHION Disc ©). After straight stitching the fitted seam on the wrong side, press both seam allowances in the same direction. From the right side, top stitch with a fine zigzag setting (2½ Bight), letting the needle enter the seam line and then the seam thickness. This zigzag setting is found to be particularly suitable where flat bias seams are desired.

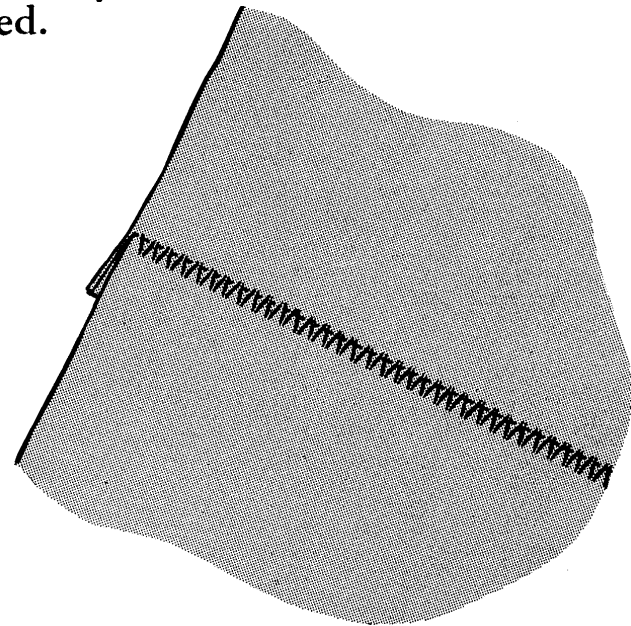

SEAMS

FLAT FELLED SEAMS

Zigzag stitching gives strength and durability to flat felled seams.

Form the seam to the right side of the fabric, taking full seam allowance, using a zigzag stitch (FASHION Disc®, 3 Bight).

Press the seam to one side keeping the right side of the zigzag stitch uppermost. Trim away half of the under seam edge. Fold the upper seam edge evenly over the trimmed seam, press and top stitch.

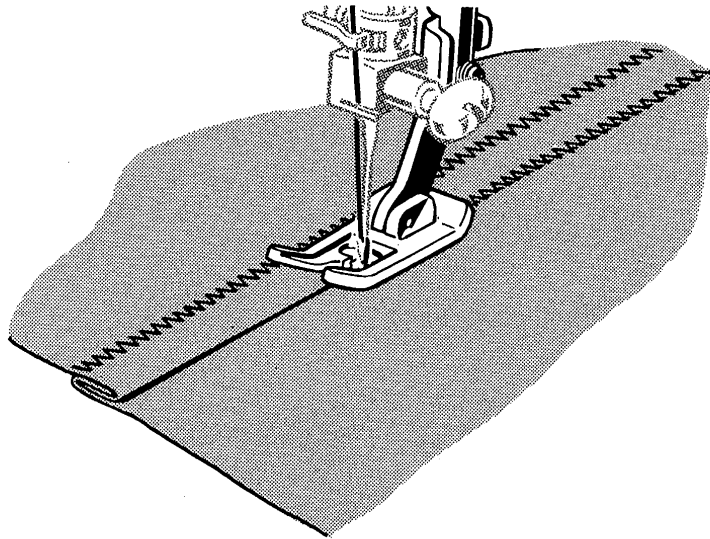

KNIT FABRIC SEAMS

A fine zigzag stitch (FASHION Disc®, Bight Lever between 5 and 2) is ideal for seaming knit fabrics. It is particularly suitable for underarm seams, or other seams where elasticity and give are needed.

For neckline and waistline seams, where a stay is needed to prevent undue stretching, this same stitch can be used to apply seam tape. To insure a flat, smooth finish, position the seam tape with the edge exactly on the seam line. If seam is curved, pre-shape tape to fit by steaming, and baste in place.

Stitch, allowing the needle alternately to enter the seam tape and seam line.

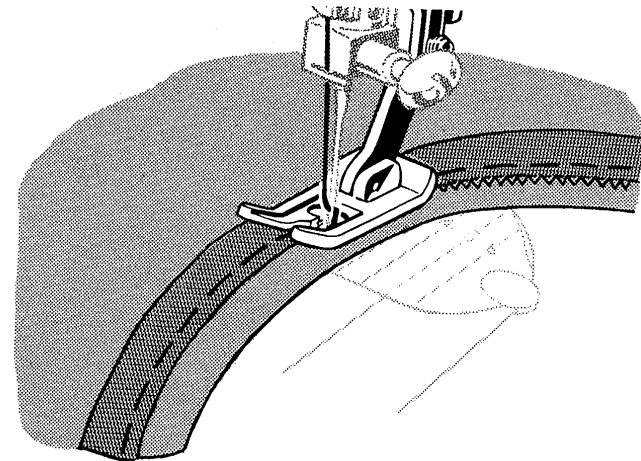

SEAM FINISHES

Seam edges support the garment and should be given a durable finish where fabrics have a tendency to ravel.

The zigzag stitch (FASHION Disc®) is ideal for such finishing. Place the stitching near the edge of the seam allowance, and then trim away excess fabric.

For an overedged seam, the blind stitch (FASHION Disc®) makes a durable, bulkless finish. It is particularly suitable for straight grain, lengthwise seams.

Seam edges should be trimmed evenly, and the stitch then formed over the raw edge.

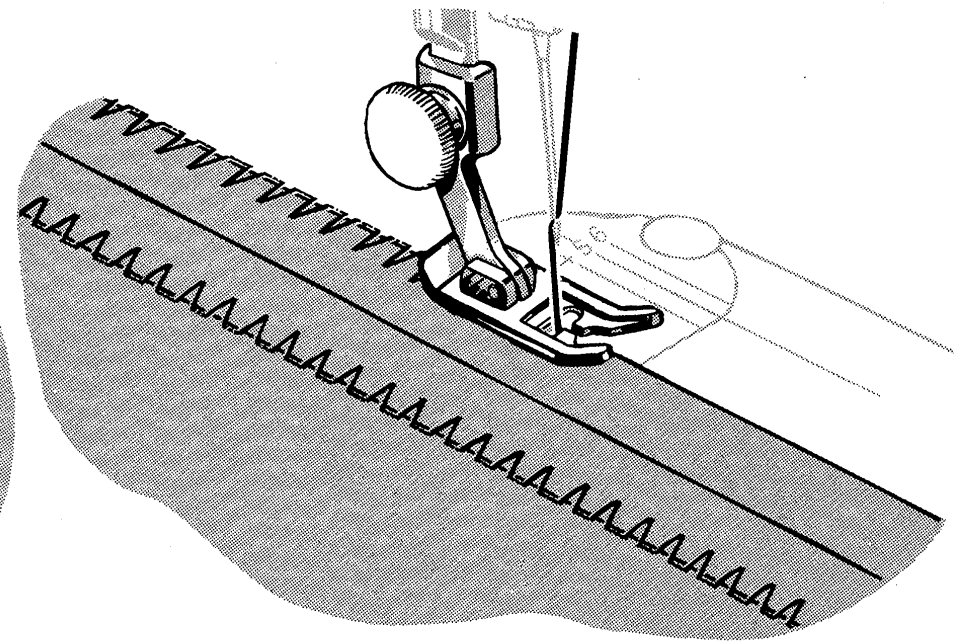
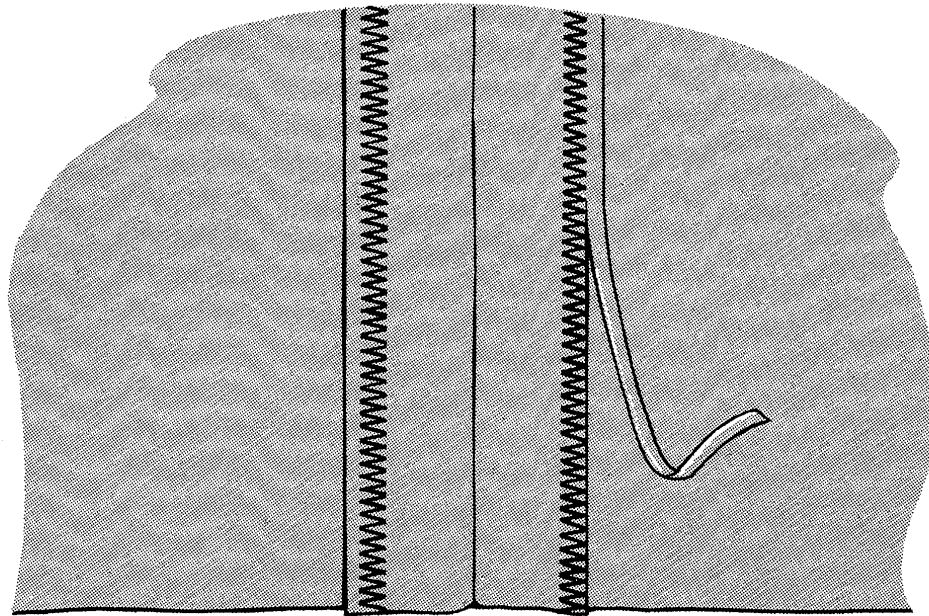

DARTS

Darts provide fit and contour in a garment and should be accurately stitched.

A straight stitch dart is usually formed by stitching from the seam edge, tapering gradually to the point, where the last 3 or 4 stitches parallel the fold. Stitch beyond the fabric to form a thread chain $\frac{1}{2}$ to $\frac{3}{4}$ inch in length. Tie the thread ends into a single knot close to the stitching.

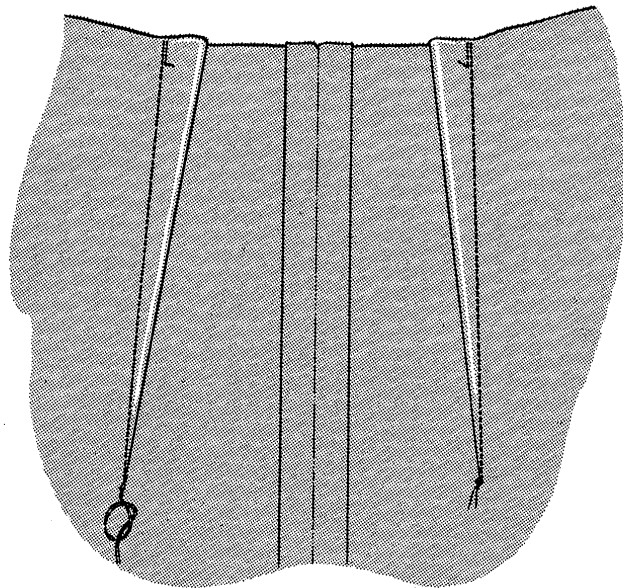

SINGLE THREAD DARTS

Darts add styling and interest when stitched with the fold to the outside of garment. Thread ends at the point of the dart are eliminated when the single thread principle is employed.

Unthread the needle. Use the thread leading off the bobbin and rethread the needle from back to front. Tie bobbin and upper threads together.

Draw bobbin thread up through threading points, winding enough on the spool to complete a single dart. Lower the needle into the very edge of the fold at the point of the dart. Take any slack out of the thread by turning the spool. Lower the presser foot and stitch carefully toward the seam edge.

This method is also ideal for inside darts in sheer fabrics as thread ends are eliminated at the point of the dart.

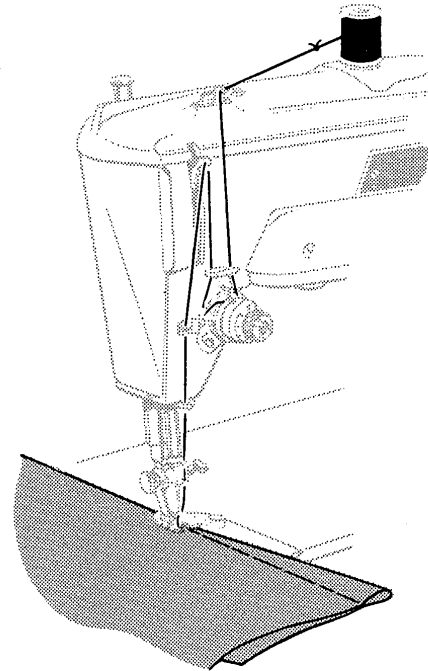

DARTS IN INTERFACING

Non-woven interfacings can be shaped without bulk with zigzag stitching (FASHION Disc®). The multiple stitch zigzag (FASHION Disc®) may also be used.

Cut out the dart allowance on the stitching line and bring the raw edges together. Pin, over a muslin stay, and stitch. Back stitch at both ends.

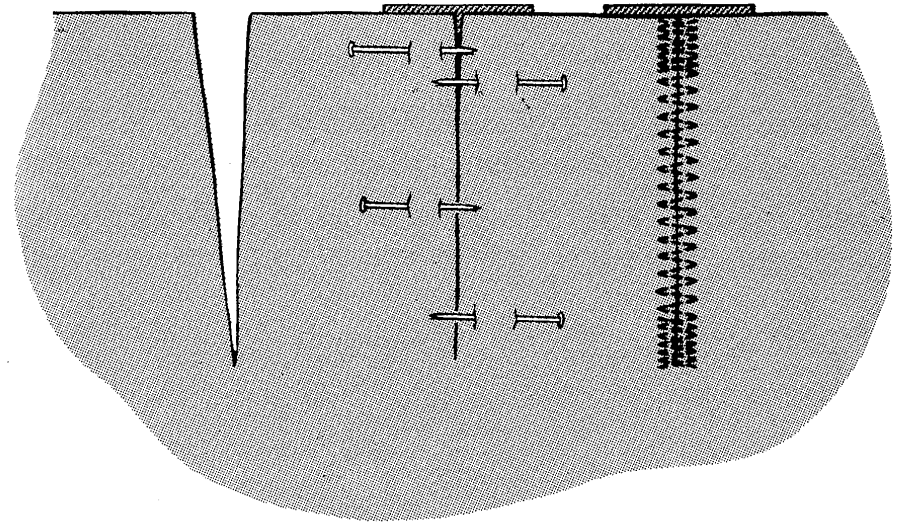

BLANKET BINDING

The multiple stitch zigzag (FASHION Disc®) is an excellent stitch for applying blanket bindings and affords both a decorative and durable finish. Remove worn binding. Baste new binding securely in place and stitch. Adjust pressure, if necessary, to accommodate the thickness of the blanket.

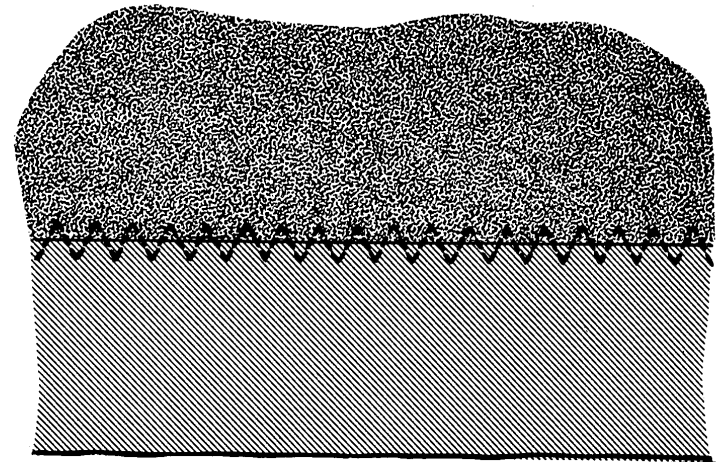

MENDING

Zigzag stitching is well suited for all types of household mending. Multiple stitch zigzag (FASHION Disc 9) provides a firm, flexible bond for the repair of rents and tears, and is ideal for the reinforcement and application of elastic. Stitch length and width are regulated according to need.

Rent or Tear. Trim away ragged edges. Place an underlay to the wrong side of the tear for reinforcement. Using the multiple stitch zigzag (FASHION Disc 9), follow the line of the tear bringing the edges together. Shorten the stitch length at ends and corners to give extra strength.

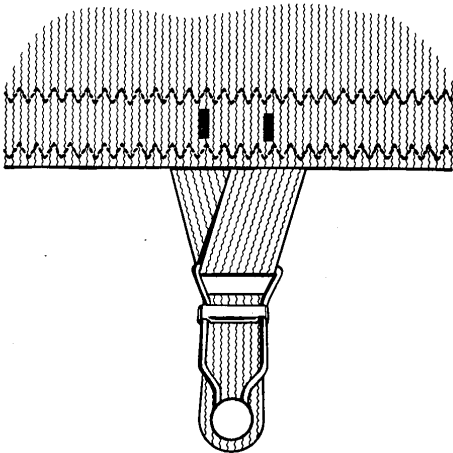

Application of Elastic.

Elastic, such as used in waist bands, must be stretched as it is applied, to insure fullness required in the garment.

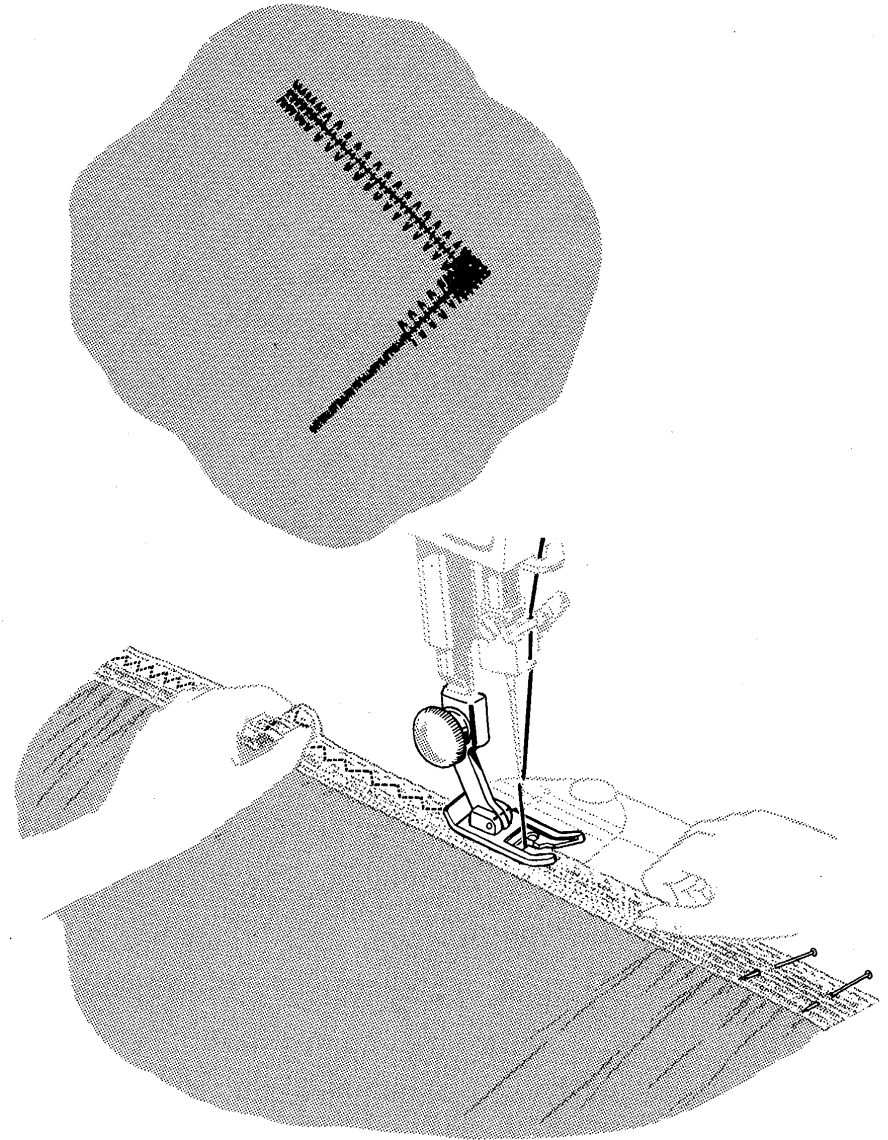

THE SEAM GUIDE

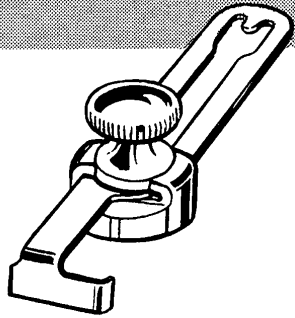

The seam guide aids in attaining uniformity of seam width. It provides for stitching to be spaced at any distance between $\frac{1}{8}$ " to $1\frac{1}{4}$ " from the edge of the fabric.

APPLICATIONS

Seams
Top Stitching

Blind Stitching
Decorative Stitching

The attachment is used in connection with a presser foot.

It is secured to the bed of the machine in either of the threaded holes to the right of the needle.

SEAMS

To guide seam stitching straight and parallel to the edge of the fabric, adjust the attachment for proper seam width. Align the guide with the presser foot. Adjust the machine for straight stitching.

Pin seam edges and baste if necessary. Hand basting can be eliminated on easy-to-handle fabrics. Place pins with the points toward the seam edge so they nip into the fabric at the stitching line. The hinged presser foot will ride freely over the points. Guide the fabric edges lightly against the guide while stitching.

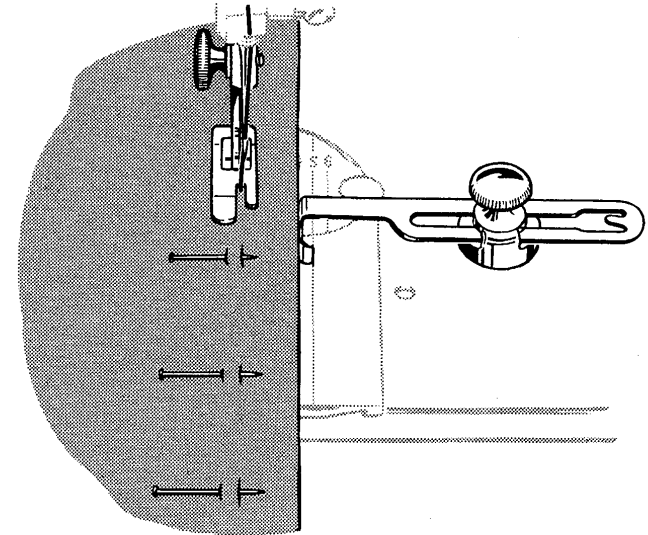

Curved seams require additional treatment in handling. A shorter stitch will provide greater elasticity and strength. Set the attachment at an angle so that the end closest to the needle acts as a guide.

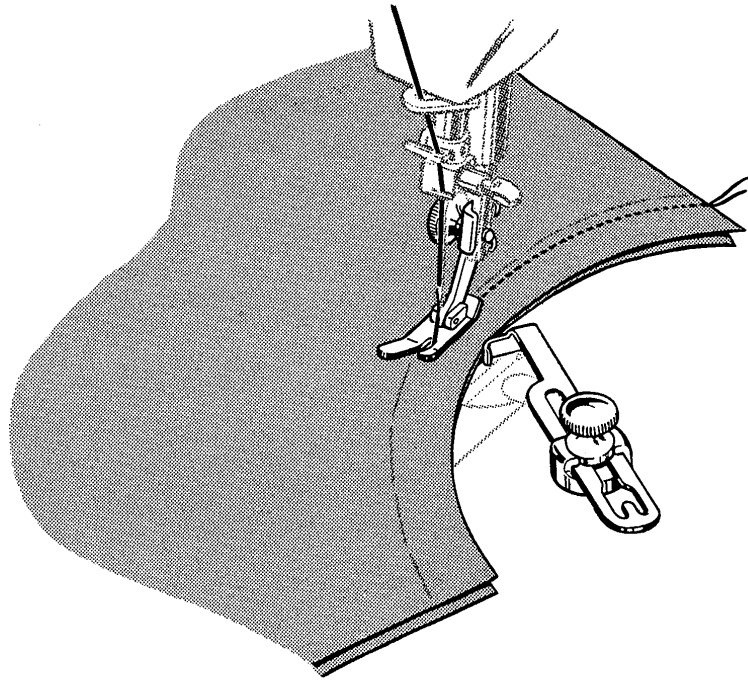

TOP STITCHING

A simple and practical way to accent the lines of a garment and at the same time give additional firmness.

Either single or multiple rows of stitching can be expertly placed along lapels and facing edges, around collars and pockets and as a hem finish.

A subtle effect may be achieved by using straight stitching, or a decorative touch may be added by using any of the attractive stitch patterns accomplished with this machine.

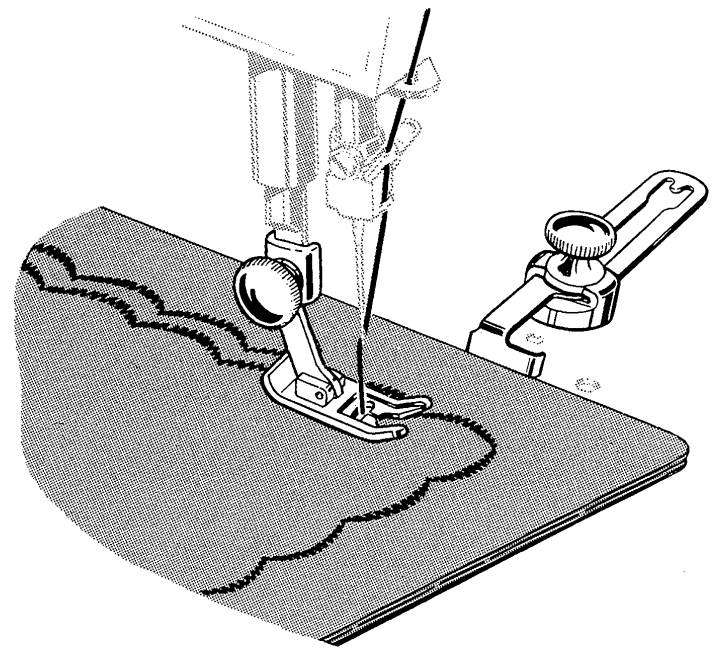

BLIND STITCHED HEMS

FASHION DISC: BLIND STITCH ⑧
 BIGHT CONTROL: 2-5
 NEEDLE POSITION: CENTER
 STITCH LENGTH: 10-20
 PRESSER FOOT: GENERAL PURPOSE
 THROAT PLATE: GENERAL PURPOSE
 SEAM GUIDE

Blind stitching provides a durable hem finish that is almost invisible, and comparable to hand sewing. It is easily suited to straight as well as circular hems. Taped, bound, turned or unfinished hem edges can all be blind stitched with equal ease.

Mark, turn and press the hem in the usual way. Place a basting guide line approximately $\frac{1}{4}$ " from the top hem edge.

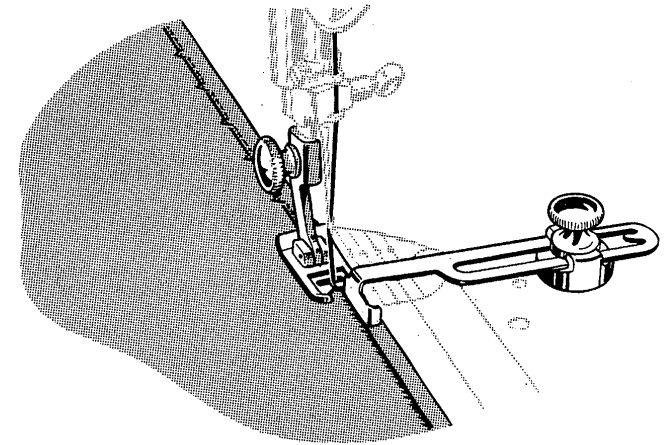
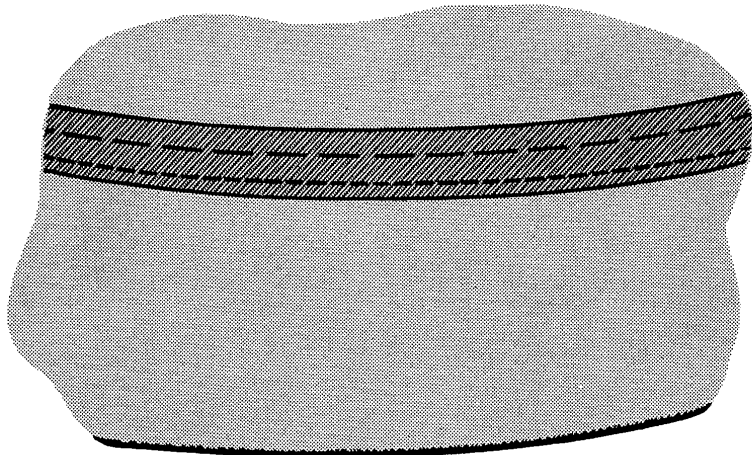

Insert FASHION Disc ⑧. This disc produces four straight stitches, separated by a single sideward stitch to the left.

Bight Lever setting for width is determined by the weight and texture of the fabric used.

Place the hem edge over the feed of the machine, turn back the bulk of the fabric to the line of basting, thereby creating a soft fold.

Position the work so that the straight stitches are made on the hem edge and the sideward stitches pierce the fold.

The stitch length will regulate the distance between the blind stitches (10 to 20 stitches per inch).

Adjust the seam guide over the right toe of the foot until it rests next to the soft fold. While stitching, feed the fold against the flat of the guide.

A test sample in self-fabric should be made to determine correct settings.

THE ZIPPER FOOT

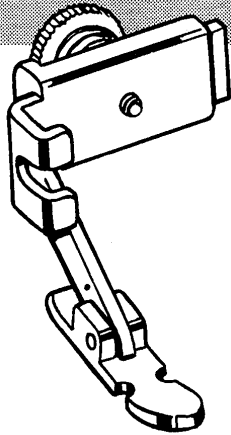

This foot is designed to facilitate the placement of stitching close to a raised edge. The hinged feature of this foot insures even feeding over pins, heavy layers of fabric or cross seams. It is attached to the machine in place of the regular presser foot, and may be adjusted to either the right or left side of the needle. Straight stitch or zigzag settings may be used.

APPLICATIONS

Zipper Insertions
Corded Seams

Tubular Cording
Slip Cover Welting

Preparation. Secure the zipper foot to the presser bar as you would the regular presser foot. Adjustment to the right or left of the needle is made by loosening the thumb screw at the back. Check

the position of the foot by lowering the needle into the side notch, making sure it clears the foot. Lock it into position by tightening the thumb screw.

ZIPPER INSERTION

BIGHT CONTROL: S
NEEDLE POSITION: CENTER
THROAT PLATE: GENERAL PURPOSE
ZIPPER FOOT

Skirt Zipper. Machine baste the placket opening of the skirt and press this seam open. Attach the zipper foot to the machine and position it to the right of the needle. Open the zipper. Place the zipper face down on the seam allowance with the edge of the teeth at the seam line. Turn the back seam allowance away from the body of the skirt. Stitch the zipper tape to the seam allowance.

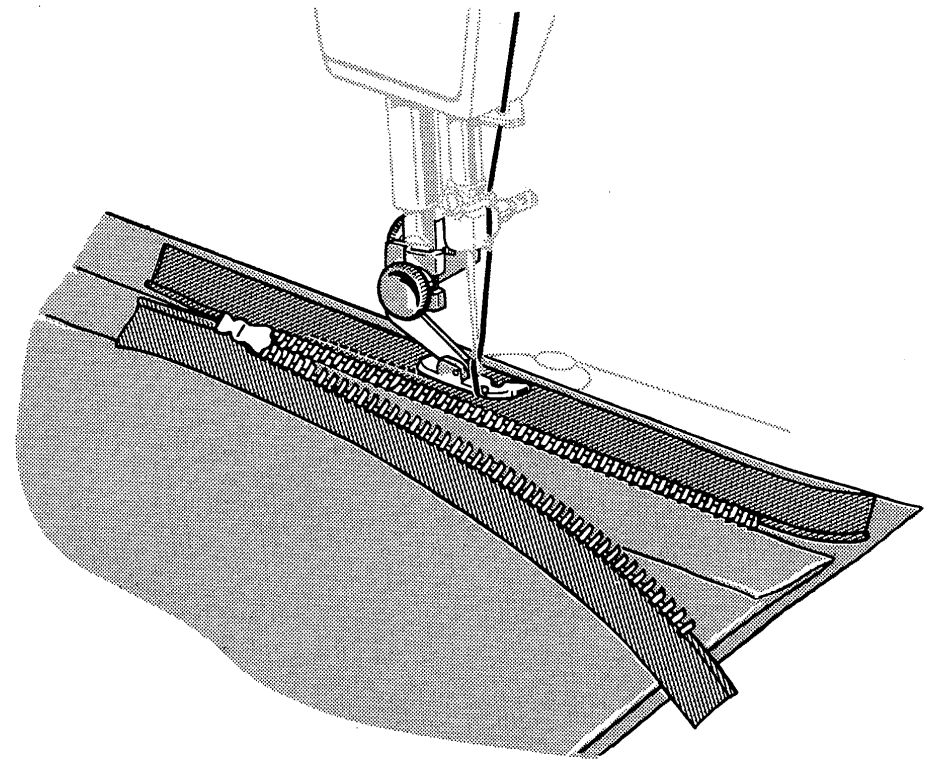

ZIPPER INSERTION

Move the foot to the left. Close the zipper and turn it face up. Smooth back the seam allowance at the edge of the zipper. Top stitch it to the tape close to the folded edge.

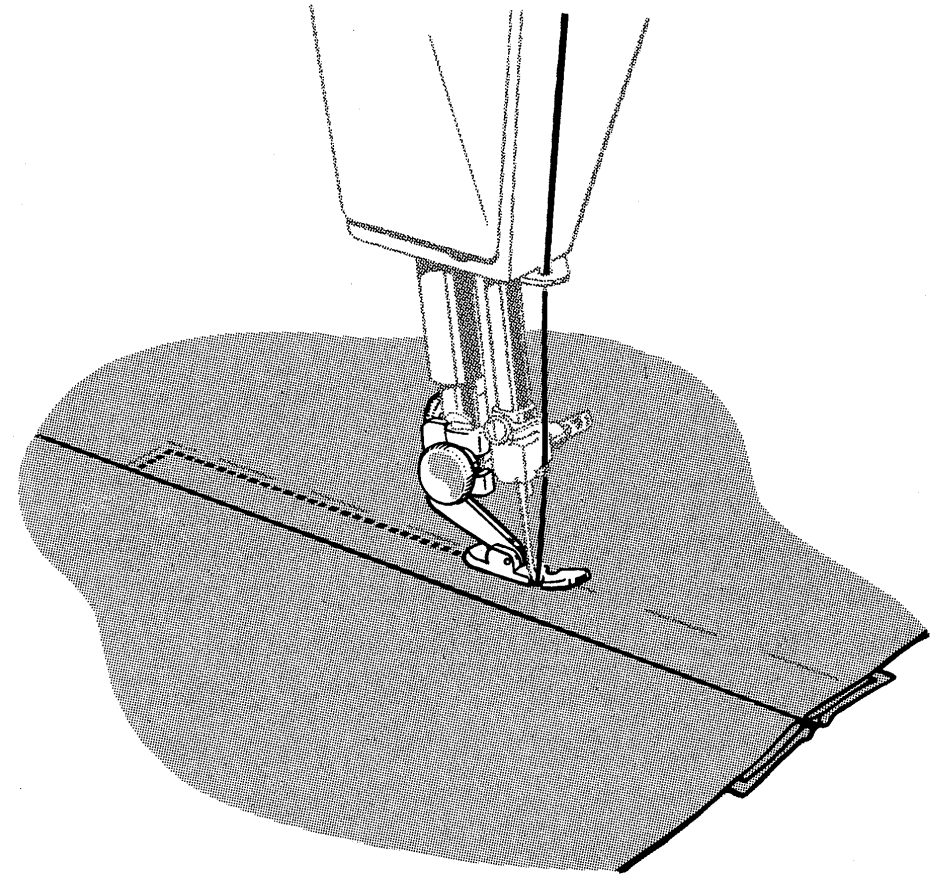
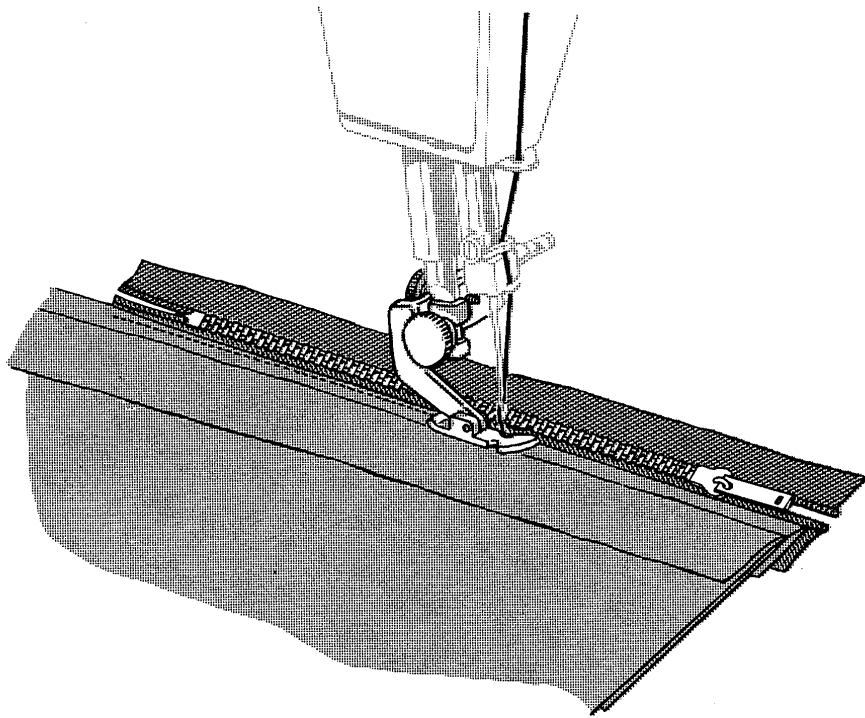

Turn skirt to the right side and fold zipper to the front of the garment. Pin in place from the right side. Baste. Move the foot to the right. Stitch across the lower end of the zipper and up to the waistline. Remove basting.

BLIND STITCHED ZIPPER INSERTION

Blind stitching the final step of a zipper insertion results in a fine finish that is almost invisible and comparable to hand sewing. Particularly suitable for chiffons, sheers, velvets and all delicate fabrics where top stitching would be too harsh.

Allow a $\frac{7}{8}$ " seam allowance. Start the insertion in the usual way, through steps 1 and 2 (pages 67 and 68) but omit final top stitching.

Work from the right side of the garment and pin the front of the zipper tape into position.

Roll the work over finger to ease fabric and pin through all thicknesses. Baste about $\frac{3}{8}$ " from seam line to provide guide for blind stitching. Remove pins.

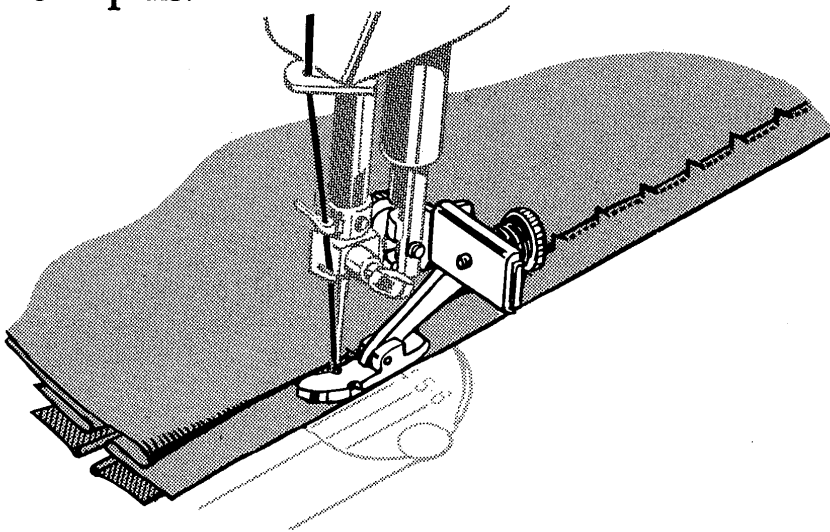

FASHION DISC: BLIND STITCH ⑧
 BIGHT CONTROL: $2\frac{1}{2}$ OR 3
 NEEDLE POSITION: CENTER
 THROAT PLATE: GENERAL PURPOSE
 STITCH LENGTH: 12
 ZIPPER FOOT

Set stitch and adjust zipper foot to the right side of the needle.

Turn garment inside out. Place zipper tape over feed of machine and turn back the front section of garment to line of basting, creating a soft fold. Position work so that the straight line of stitching is made through front seam allowance and zipper tape, and the sideward stitch pierces a few threads of the fold. Lower presser bar and stitch slowly. Remove bastings. Press.

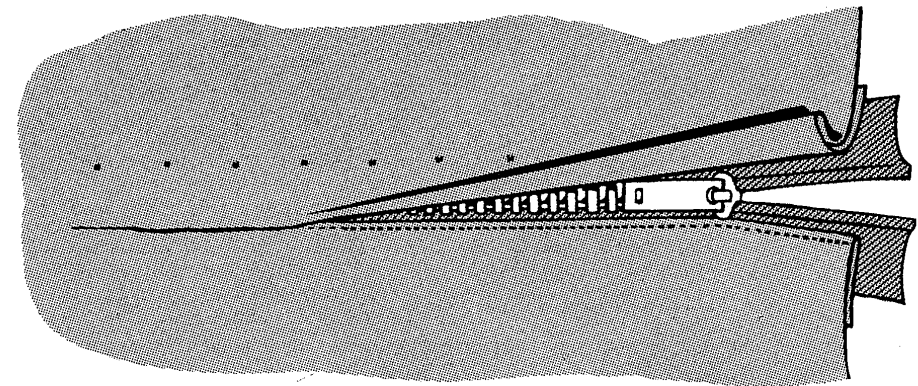

CORDED WELTING

BIGHT CONTROL: S

NEEDLE POSITION: CENTER

THROAT PLATE: GENERAL PURPOSE OR
STRAIGHT STITCH

ZIPPER FOOT

Cable cord comes in a variety of sizes and when covered with a firmly woven fabric makes a corded welting that is an excellent seam finish.

This welting is prepared in advance and then stitched into the seam. Cut a true bias strip $1\frac{1}{4}$ inches wide, plus three times the width of the cord of either self or contrasting fabric. Sew strips together on the lengthwise grain to obtain desired length.

Adjust machine for straight stitching. Adjust zipper foot to the left side of the needle. Encase the cord in the bias strip, raw edges even. Lower presser bar. Stitch close to the cord, using a stitch length slightly longer than for seaming the weight of fabric being used. Do not crowd the stitching against the cord.

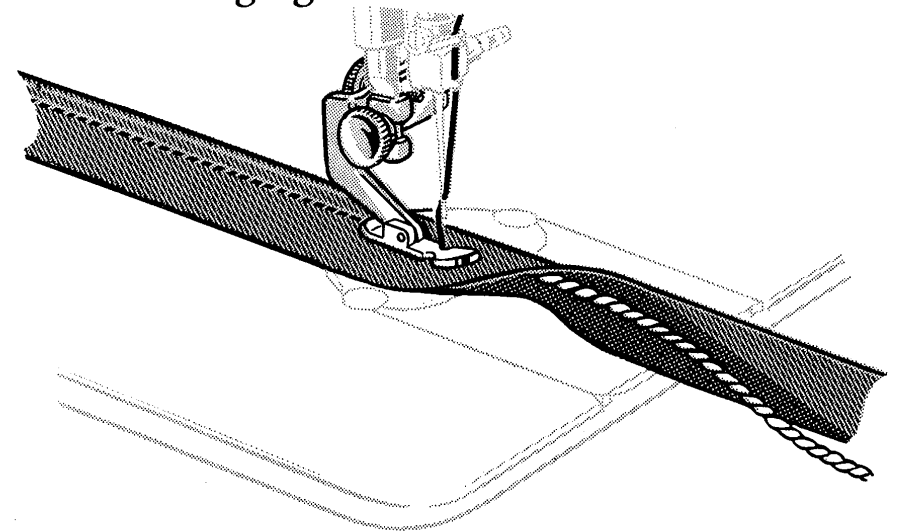
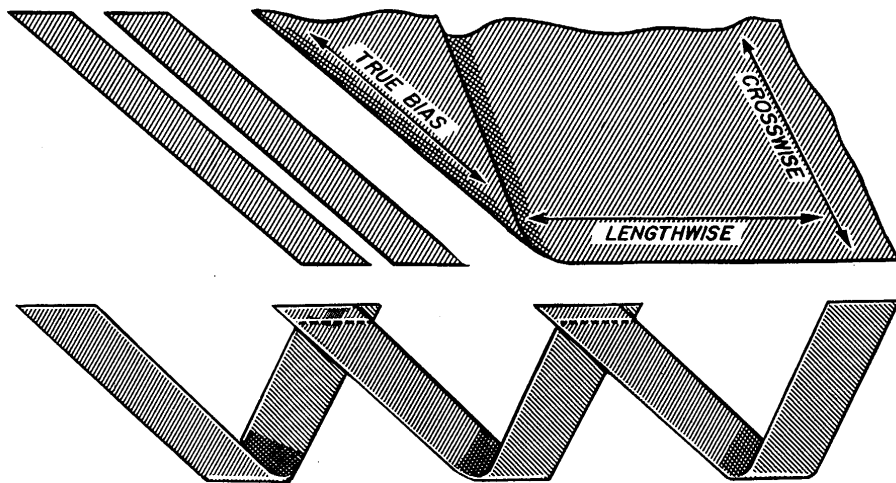

CORDED SEAMS

BIGHT CONTROL: S

NEEDLE POSITION: CENTER

THROAT PLATE: GENERAL PURPOSE OR
STRAIGHT STITCH

ZIPPER FOOT

The corded seam is a typical treatment for slip covers, children's clothes, blouses and lingerie.

When cording a seam the zipper foot is usually adjusted to the right of the needle so that the bulk of the work will fall to the left.

Adjust machine for straight stitching. Attach the corded welting to the right side of a single

seam edge, with the same stitch length used to make the welting (**page 70**). Guide the edge of the foot next to the cord, but do not crowd.

Place the attached corded welting over the second seam edge, and pin or baste together.

Keep the first stitching uppermost as a guide and position the seam under needle. Stitch, this time crowding the foot against the cord.

This method produces evenly joined seam edges and tightly set welting.

Curved seams are corded as easily as straight seams, except that a shorter stitch length is used. Since the seam allowance of the welting is bias, it is not difficult to shape it to the seam.

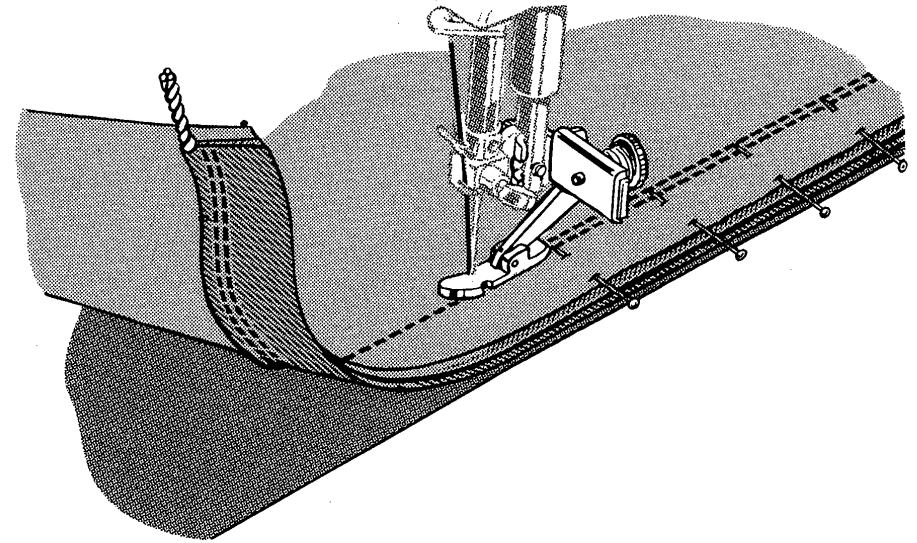
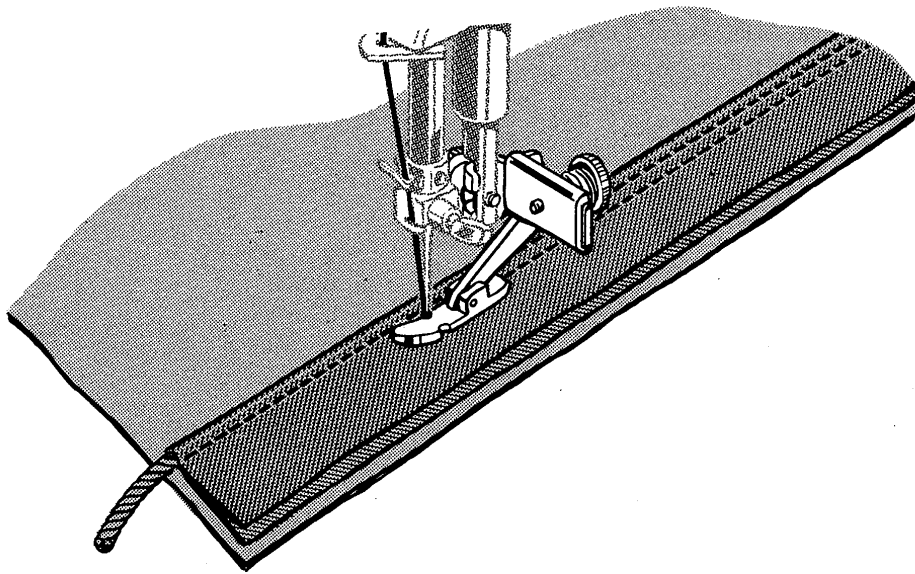

THE FOOT HEMMER



The narrow hemmer forms and stitches a perfectly turned hem without basting or pressing. It is attached to the machine in place of the regular presser foot.

APPLICATIONS

Fine hems
Edging ruffles
Sheer seams

Hemming with lace
Lace insertion
Lingerie finishes

BIGHT CONTROL: "S"
NEEDLE POSITION: CENTER
THROAT PLATE: GENERAL PURPOSE
FOOT HEMMER

HEMMING

Adjust machine for straight stitching. At the very edge of the fabric form a double $\frac{1}{8}$ " fold. Crease this fold for about 2". Draw the bobbin

and needle threads under the hemmer. Place the fabric under the foot and stitch through the creased fold for several stitches. Hold the thread ends in the left hand and guide the raw edge in front of the hemmer evenly into the scroll. Sew slowly, still holding thread ends until the hem is well started.

Soft fabrics will enter the scroll best with the foot down; firm, crisp materials with the foot raised.

Even feeding is essential to good hemming. The same width of fabric must be kept in the scroll of the hemmer at all times. A little practice will result in perfectly formed hems.

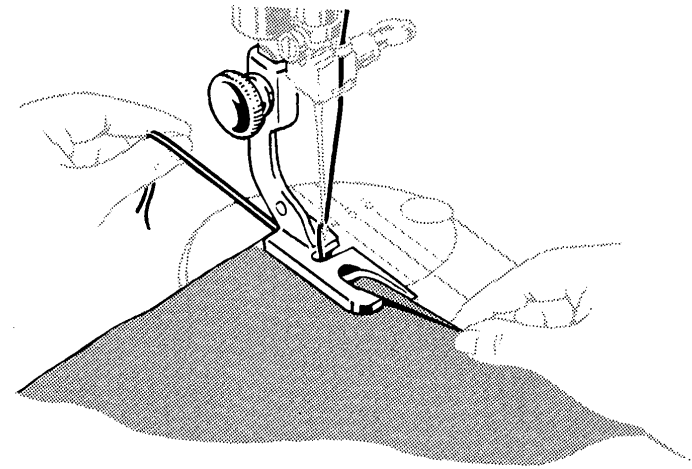

HEMMING WITH LACE

FASHION DISC: ZIGZAG ①
 BIGHT CONTROL: 3
 NEEDLE POSITION: CENTER
 THROAT PLATE: GENERAL PURPOSE
 FOOT HEMMER

Most of the popular kinds of lace edging and insertion can be applied with the Foot Hemmer. It is an excellent way to trim children's clothes and to finish lingerie hems.

Lace Applied Over Hem. Fold and start the hem in the usual way (page 72). Starting about 1" down from the end of the lace, place the selvage under the needle and lower needle to hold lace firmly. Raise the foot slightly and slip the lace under the back portion of the foot without disturbing the position of the fabric. Stitch slowly, guiding the fabric with the right hand, the lace with the left. Take care not to stretch the lace.

Lace Applied Under Hem. When using lace underneath the fold of a hem, the procedure is the same as when making a hemmed seam. Slip the lace in from the left as you would the second piece of fabric. This method is used where a neat finish is desired on both sides of the material.

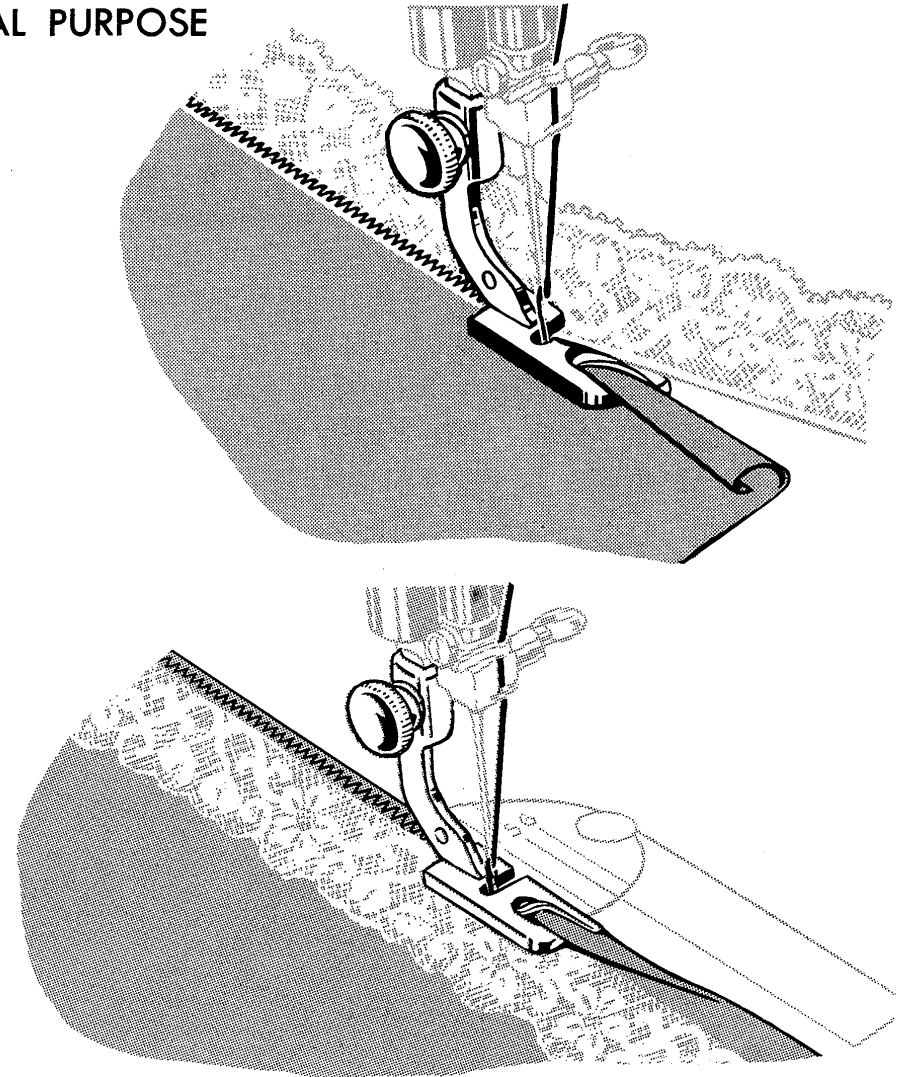

DECORATIVE HEMS

FASHION DISCS: ALL
 BIGHT CONTROL: 2 THRU 4
 NEEDLE POSITION: CENTER
 THROAT PLATE: GENERAL PURPOSE
 FOOT HEMMER

Narrow hem edges can be turned and decorated in one operation using the foot hemmer and a stitch pattern.

This time-saving finish is especially suited to ruffle edges and aprons.

Lingerie and most delicate fabrics can be attractively finished with a soft shell edge. This effect is obtained by hemming with FASHION Discs ⑧ (Blind Stitch) and ⑨ (Multiple Stitch Zigzag) with Bight Lever at 4.

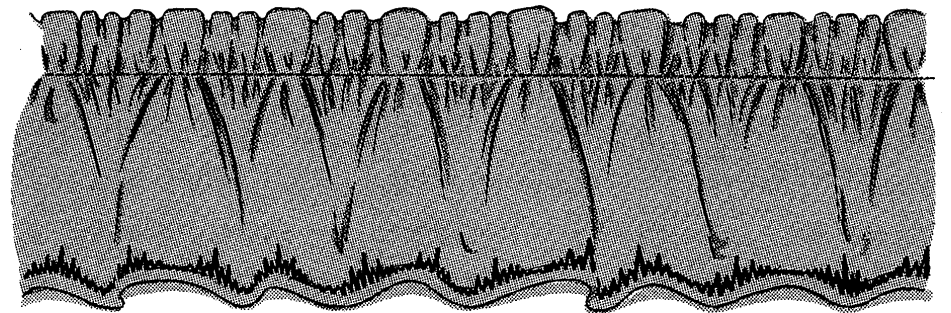
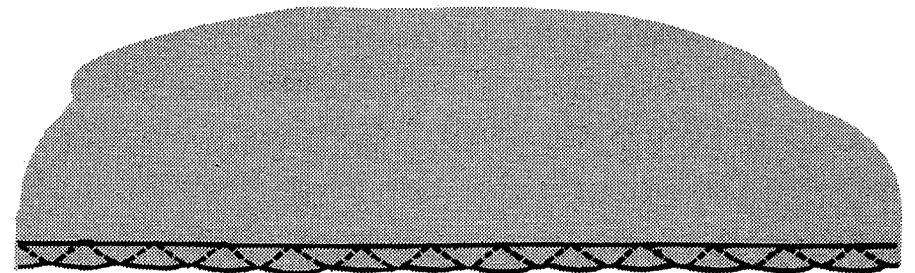
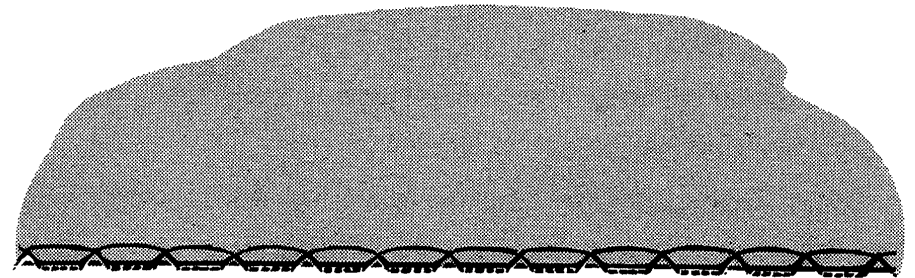
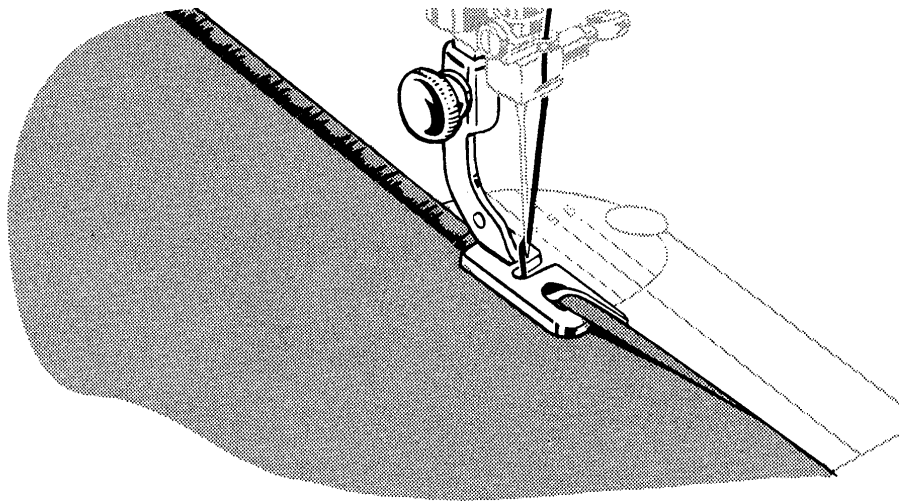

MULTI-SLOTTED BINDER

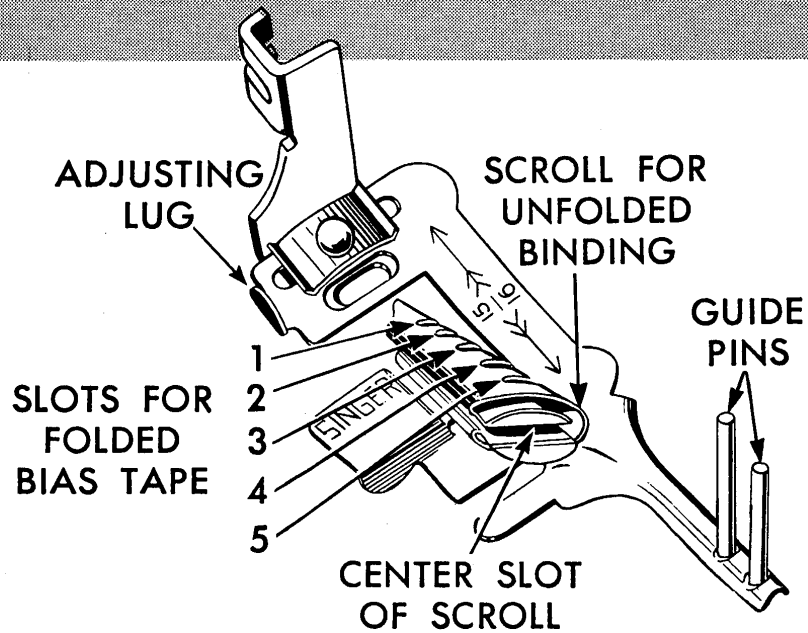

FASHION DISCS: ALL
 BIGHT CONTROL: "S" THRU 5
 NEEDLE POSITION: CENTER
 THROAT PLATE: GENERAL PURPOSE
 MULTI-SLOTTED BINDER

Cut binding diagonally to form a long point. Commercial binding in sizes 1 to 5 is inserted from the right into the appropriate slot in the scroll. Unfolded bias $\frac{1\frac{5}{16}}$ of an inch wide is inserted into the opening at the end of the scroll.

Pull binding through scroll until the evenly folded edges are under the needle. The free length of the binding is held between the guide pins.

Adjust machine for either straight or zigzag stitching.

Insert the edge to be bound into the center of the scroll. The stitching is positioned close to the edge of the binding by moving the scroll portion of the attachment to the right or left by means of the adjusting lug.

The multi-slotted binder is used to apply commercial binding as well as self fabric bias to an unfinished edge.

This colorful trim is attractive when applied to children's wear, aprons and fabric furnishings. It is a practical finish for seam edges that ravel and for making bound seams.

The attachment will accommodate both straight and zigzag stitching.

MULTI-SLOTTED BINDER

Lower the presser bar. Allow the attachment to do the work, merely guiding the fabric into the center of the scroll as you stitch.

Curved edges require slightly different fabric handling than straight edges.

Inside curves are straightened as they are fed into the binder. If the fabric is soft and has a tendency to stretch, reinforce the edge with a single row of stitching before binding.

Outside curves tend to lead away from the center slot of the scroll and should be guided so that a full seam width is taken at the needle point. Do not attempt to pull or straighten fabric into the full length of the scroll.

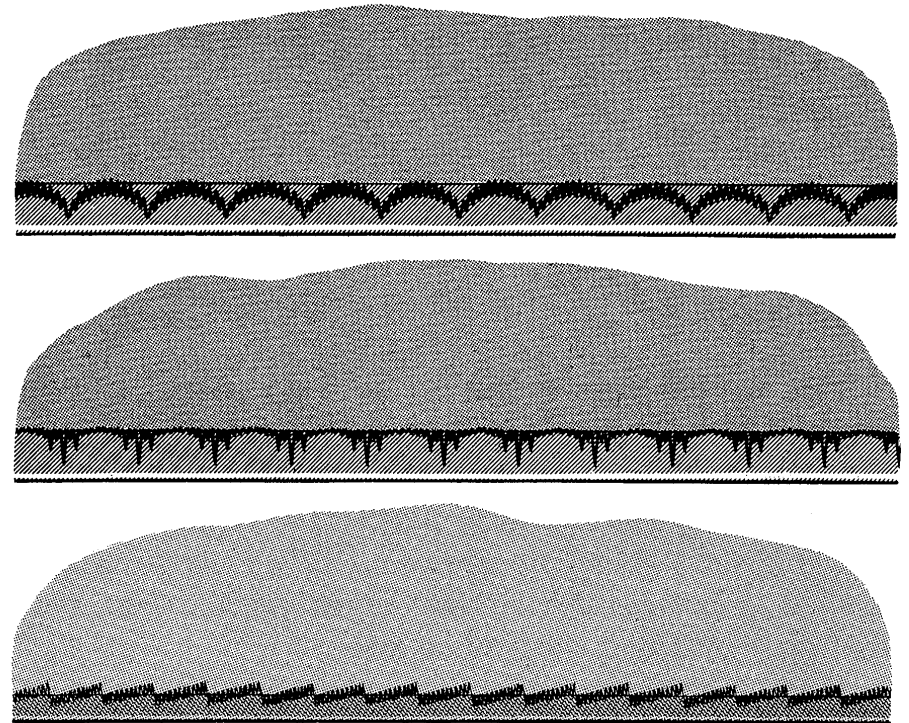
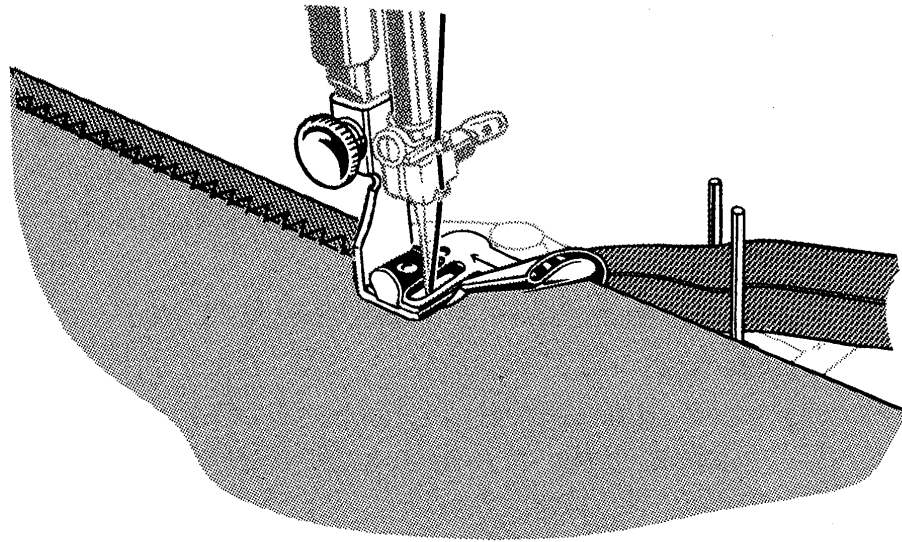

THE RUFFLER

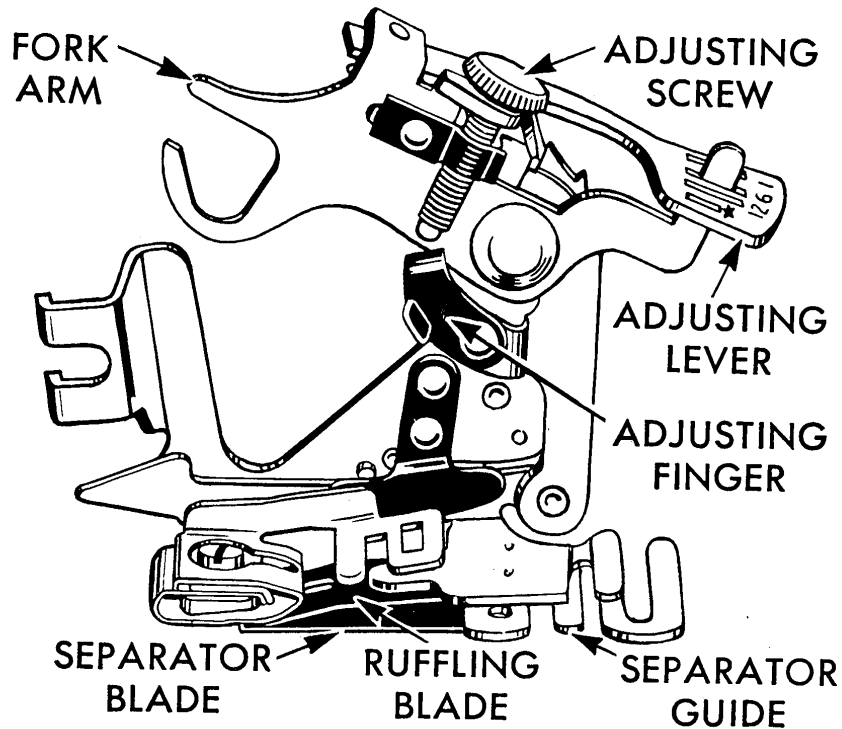

This attachment offers a simple and effective way to make gathered and pleated ruffles. Ruffles may be made separately or made and applied at the same time. The ruffler is attached to the machine in place of the regular presser foot and is used with a straight stitch setting only.

BIGHT CONTROL: "S"
NEEDLE POSITION: CENTER
THROAT PLATE: STRAIGHT STITCH
RUFFLER

Adjusting Points. 1. The adjusting lever sets the ruffler for gathers or pleats. The Number 1 space setting is for gathers, and places fullness at every stitch. Numbers 6 and 12 are space settings for pleats, spacing them either 6 or 12 stitches apart. The star is for straight stitching, and is used when grouping gathers or pleats.

2. The adjusting finger is used only for pleating and affects the width of the pleat. It is thrown out of action by bringing it out of contact with the adjusting screw, located directly above it.

3. The adjusting screw regulates the fullness of gathers or pleats. When turned down to its limit with the adjusting finger in place, the attachment is set for its deepest pleat. When turned upward to its limit and the adjusting finger out of action, the ruffler gives only a hint of fullness.

THE RUFFLER

Activating Parts. The ruffling blade and the separator blade are of blue steel and hold the material to be gathered between them. The ruffling blade forms the gathers or pleats by carrying the fabric to the needle according to the spacing and fullness to which the ruffler is adjusted. The separator guide is slotted to guide seam edges evenly and to separate the ruffle strip from the material to which the ruffle is attached.

Preparation. Raise the needle to its highest point.

Locate the attachment on the machine in place of the regular presser foot, at the same time fit the fork arm over the needle clamp screw. Make sure both the presser bar screw and the needle clamp screw are tightened securely.

Gathering. Set the adjusting lever of the attachment on Number 1 setting, and throw the adjusting finger out of action. Turn the adjusting screw for the amount of fullness desired and set the stitch length to space the fullness. The attachment is adjusted for maximum fullness by turning the adjusting screw all the way down; for less fullness turn it upward.

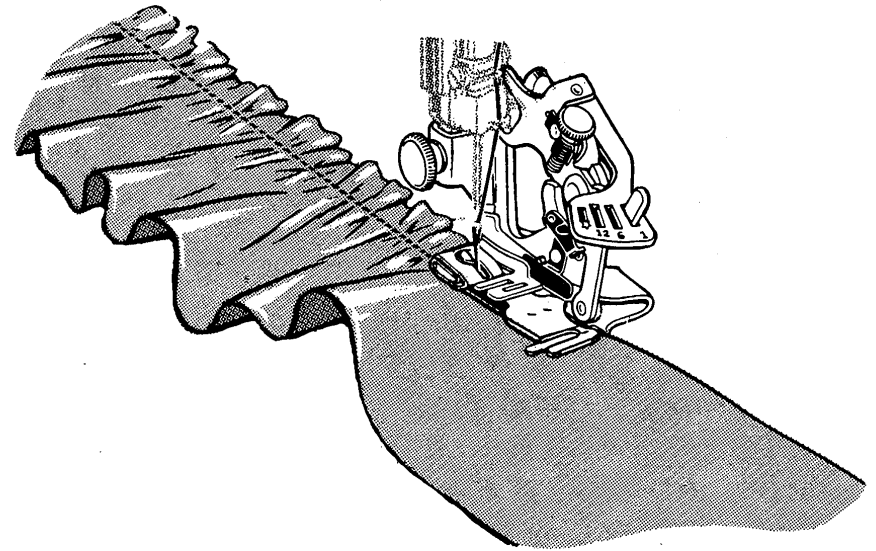

THE RUFFLER

The length of the sewing machine stitch also affects ruffle fullness. Since a given attachment setting puts an equal amount of fullness into each stitch regardless of its length, shortening the stitch (more stitches to the inch) makes the ruffle more full, lengthening the stitch (few stitches to the inch) makes it less full. For fine, closely spaced gathering use a short stitch and an upward adjustment of the adjusting screw. For deeper, less closely spaced gathering, turn the adjusting screw downward and use a medium length stitch.

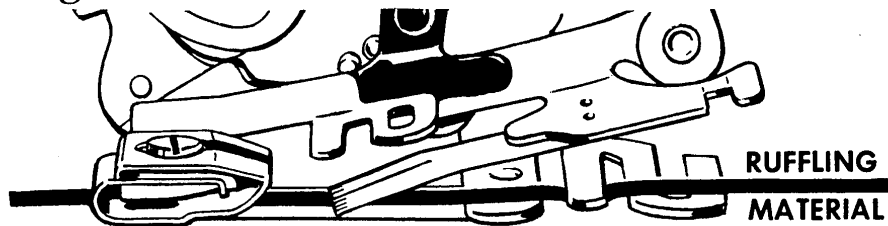

Insert the material to be gathered between the blue blades and through the first separator guide. Draw to the back of the needle. Lower the presser bar and stitch. The texture of the fabric influences the performance of the ruffler as well as the results. Soft fabrics, cut on the crosswise grain, are best adapted for gathered ruffles. Always test stitch length and ruffler setting on a scrap of self fabric before proceeding with the actual work.

Attaching Ruffle. To form and attach a ruffle in one operation, place the ruffle strip between the two blue blades and through the first separator guide, and the material to which it is to be

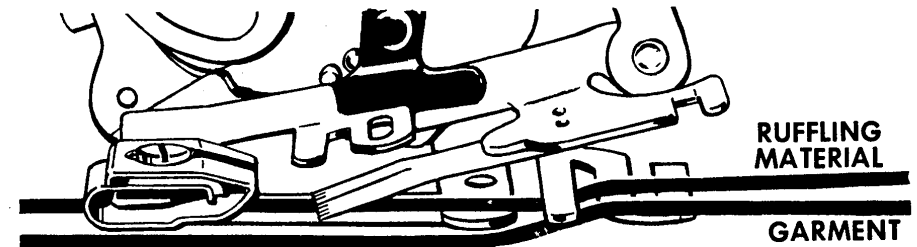

attached between the separator blade and the feed of the machine. Proceed as for plain gathering. Right sides of the fabric are placed together when the seam is to fall to the inside.

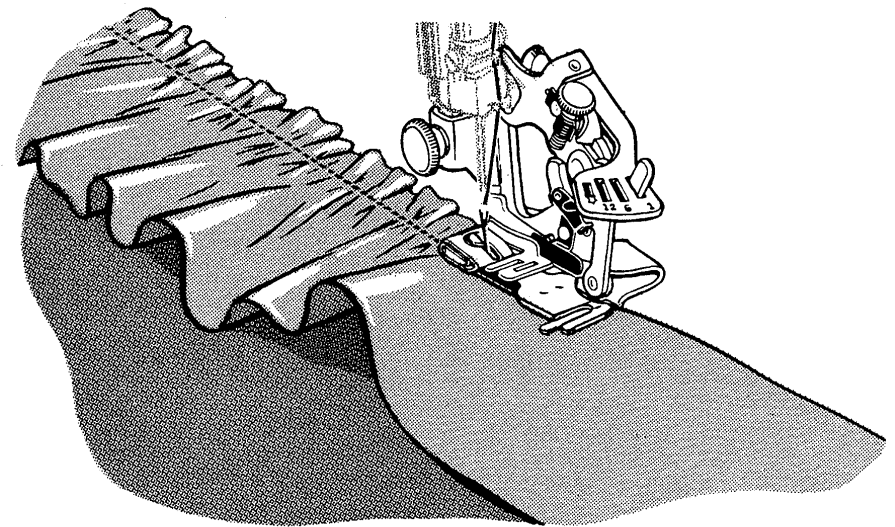

THE RUFFLER

Pleating. Move the adjusting lever of the ruffler to the space setting desired for pleats either 6 or 12 stitches apart.

For the deepest pleat, activate the adjusting finger and turn the adjusting screw downward to its maximum setting. For smaller pleats turn the adjusting screw upward.

Set stitch length. A short stitch places the pleats more closely together; a long stitch separates the pleats for a greater distance.

Insert the fabric to be pleated between the blue blades and into the first separator guide. Lower presser bar and stitch.

Crisp fabrics cut on the crosswise grain form the sharpest pleats. Glazed fabrics handle best if the glazed side is downward and the soft backing is next to the ruffler blade.

Group Pleating. By using the star setting (straight stitching) alternately with the 6 or 12 stitch setting, pleats are formed in groups. Even spacing between groups is accomplished by counting the number of stitches.

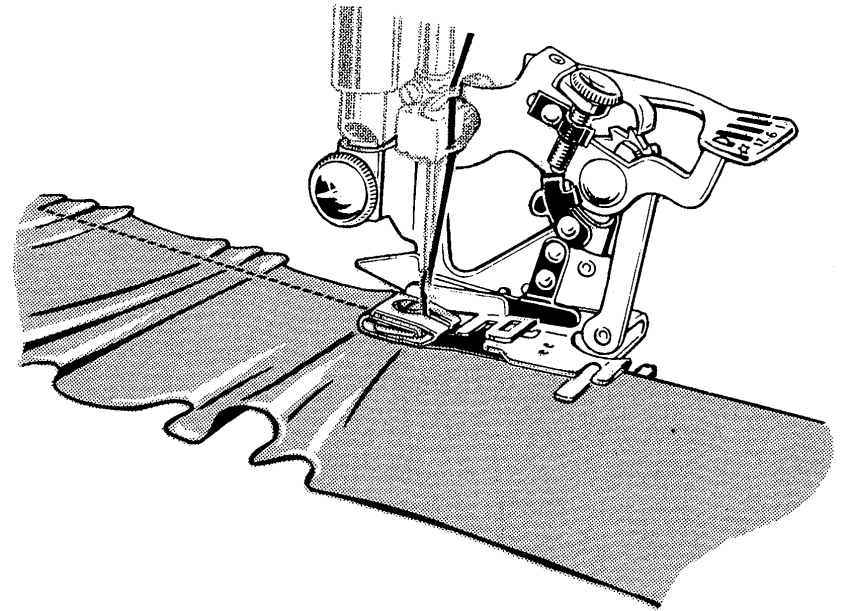
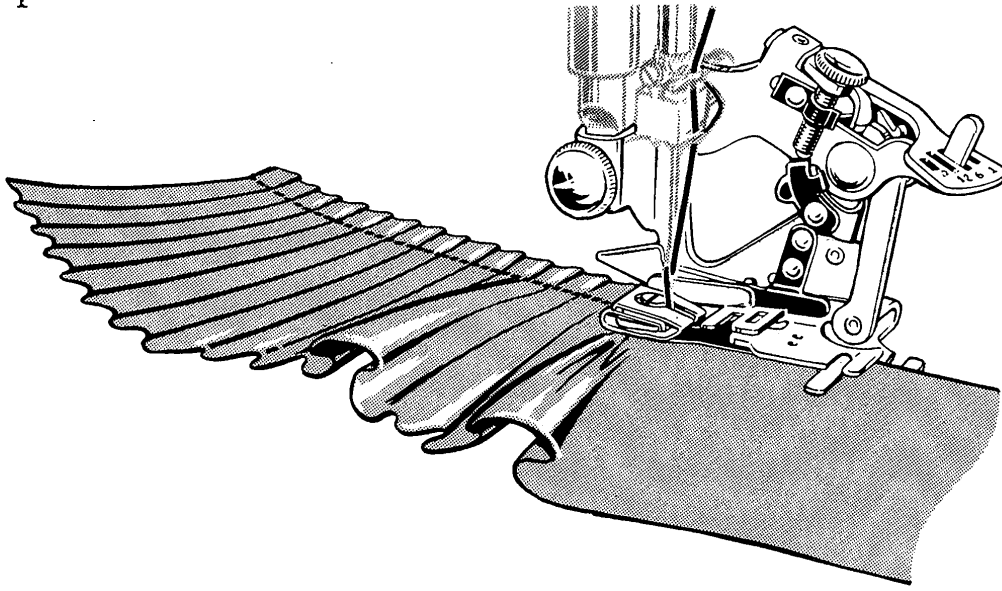

FREE MOTION WORK DARNING

BIGHT CONTROL: S
NEEDLE POSITION: CENTER
THROAT PLATE: STRAIGHT STITCH (RAISED)
PRESSER FOOT: NONE
STITCH LENGTH: FINEST

Household linens, children's clothes and knit wear of all kinds can be repaired with the darning stitch.

Trim away any ragged edges from the area to be darned. Center the worn section in embroidery hoops or the SINGER Stocking Darner (available separately) to hold it taut.

Remove the presser foot and raise the throat plate. Set Needle Position Control at CENTER, and Bight Lever at S (straight stitching).

Position the work under the needle and lower the presser bar to activate the tension. Hold the needle thread loosely with the left hand, turn the hand wheel over and draw the bobbin thread up through the fabric with the loop of the needle thread. Hold both thread ends and lower needle into fabric.

Outline area to be darned with running stitches

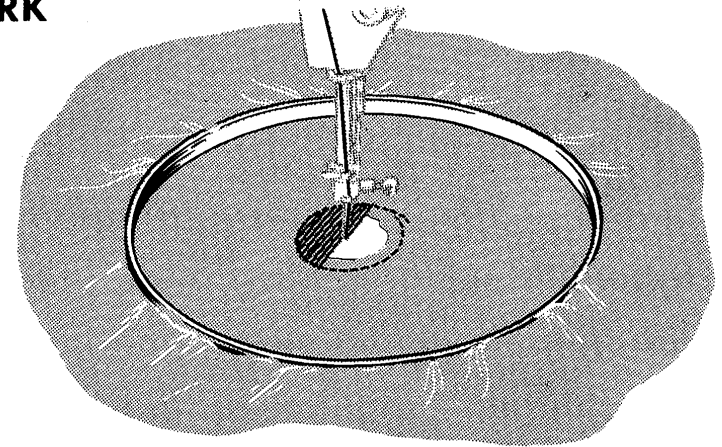

for reinforcement. Place these stitches $\frac{1}{4}$ " from the edge of the open area.

Stitch across the opening, moving the hoops under the needle at a slight angle from lower left to upper right. Keep lines of stitching closely spaced and even in length.

Run machine at a moderate speed and control the hoops with a steady continuous movement. Slow movement of hoops will produce a short stitch, while more rapid movement lengthens the stitch. Fairly long stitches are best for knit and tricot fabrics as they are softer and more flexible when the garment is worn. Short stitches are best for cottons and household linens as they approximate the weave of the fabric and are strong enough to withstand many launderings.

FREE MOTION WORK MONOGRAMS

FASHION DISC: ZIGZAG ①

BIGHT CONTROL: 2-5

NEEDLE POSITION: CENTER

THROAT PLATE: GENERAL PURPOSE (RAISED)

PRESSER FOOT: NONE

STITCH LENGTH: FINEST

Script lettering can be effectively accomplished with the zigzag stitch, when the free motion principle is employed.

Trace or mark lettering on right side of fabric. Place work in embroidery hoops large enough to encompass entire design. Be sure fabric is held taut.

Remove presser foot and raise throat plate. Use Zigzag Disc ① and set Bight Lever for desired stitch width. Use CENTER needle position.

Position work under needle and lower presser bar to engage the tension. Bring bobbin thread up through fabric at start of design. Hold both thread ends to start stitching.

Move hoops slowly, following outline of lettering. Maintain an even rate of speed so that stitches are uniformly placed.

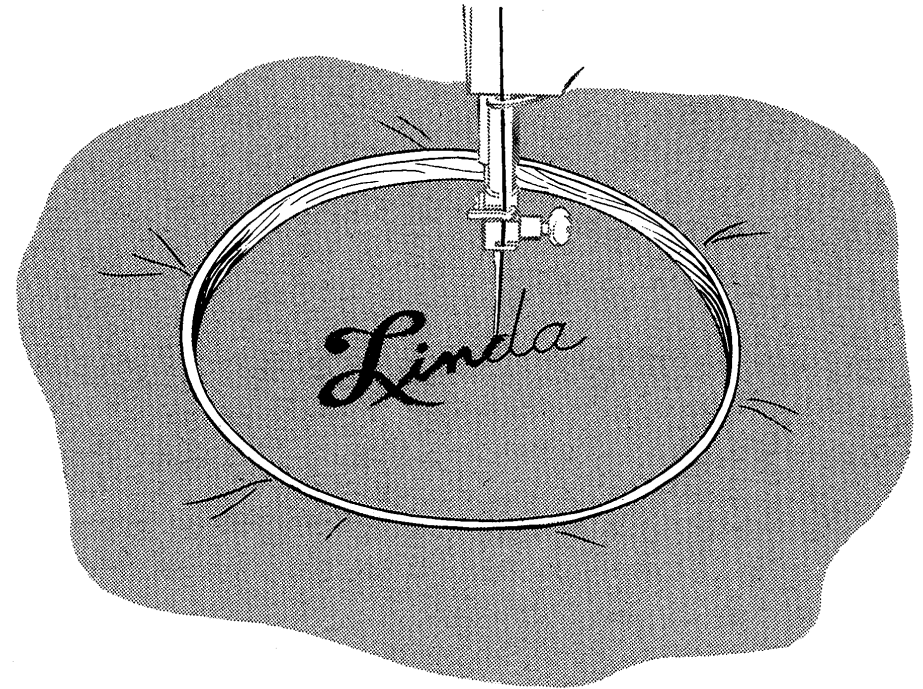

Slow movement of hoops produces a close satin stitch, while a more rapid movement lengthens stitch and results in an open effect.

Shading stitches from wide to narrow is controlled by angle at which work is placed and moved under needle.

A test sample should always be made before proceeding with actual work to determine stitch setting and spacing. Some fabrics may require addition of an underlay of crisp lawn or organdy.

FREE MOTION WORK EMBROIDERY

FASHION DISC: ZIGZAG ①
 BIGHT CONTROL: 2-5
 NEEDLE POSITION: CENTER
 THROAT PLATE: GENERAL PURPOSE (RAISED)
 PRESSER FOOT: NONE
 STITCH LENGTH: FINEST

Of special interest to those with artistic ability, free motion machine embroidery has many applications to clothing and household linens. Many lovely effects comparable to hand embroidery can be achieved.

Original free hand sketches as well as transfer patterns may be used as guides for stitching.

Prepare the machine and proceed as for free motion script lettering (**page 82**).

To achieve a dimensional effect, stitches should be laid to conform to the contour of the design. Smooth effects result when outlines are filled using a slow steady hoop movement; irregular textures when a fast side-to-side motion is employed.

Bight Lever settings are varied to accommodate the size of the area to be covered within a specific design. A test sample will help you determine the method and setting best suited to your purpose.

Placement of bar tacks in sequence can be used to form spraylike leaves and flowers. This technique adds variety and lightness to many designs.

Leaves and petals formed in this manner carry the thread from one bar tack to the next. This carrying thread adds to the attractiveness of the design, while eliminating the tying-off of thread ends.

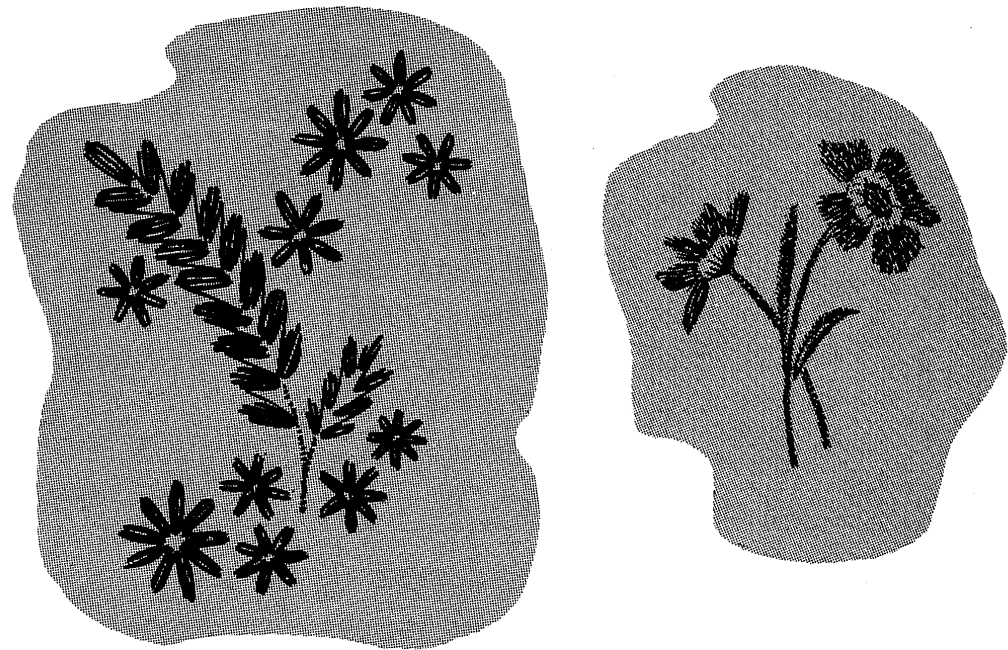

FASHION* AIDS

Available for separate purchase at your local SINGER SEWING CENTER

DARNING AND EMBROIDERY ATTACHMENT

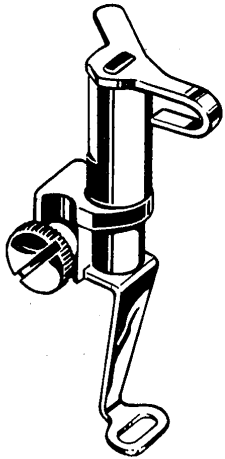

Fabrics that require skillful handling may be darned and embroidered with expert results when the Darning and Embroidery Foot is used.

This attachment is an aid to all who desire perfection in free motion embroidery and applique work.

The foot firmly holds the fabric as the needle enters and rises from the work, while fully revealing the line of design to be followed.

THE GATHERING FOOT

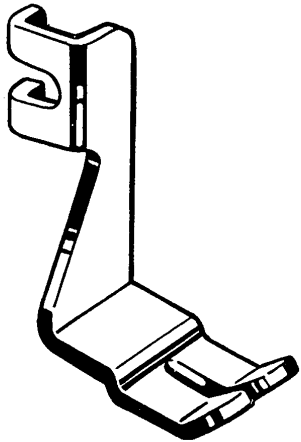

Single or multiple rows of shirring can be quickly and expertly placed with this attachment. Evenly spaced shirring is insured as this foot is designed to lock fullness into each stitch. The amount of fullness is very simply controlled by stitch length and degree of tension.

Use straight stitch setting only.

THE EDGE STITCHER

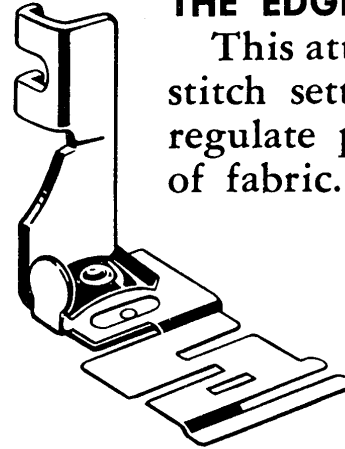

This attachment, used with the straight stitch setting, has slotted guides which regulate placement of stitching at edge of fabric.

Among its many applications are the joining and insertion of lace, tucking from pin width to 1/4", French seaming and seam piping, facing and seam finishing.

THE TUCKER

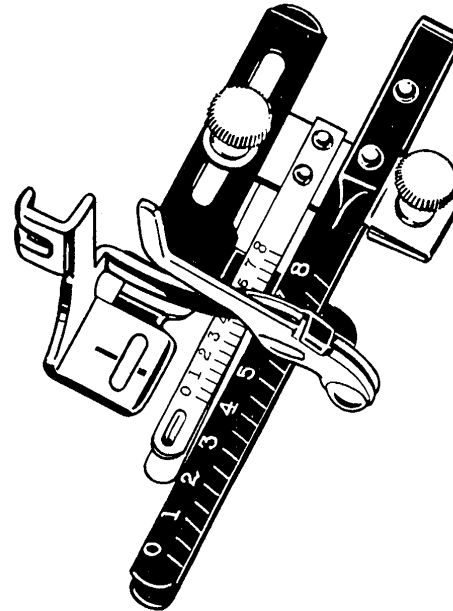

Since the beauty of tucking lies in explicit accuracy, the Tucker will contribute greatly to the attractiveness of this work.

Tucks up to 1" may be stitched and marked in one operation.

Two adjustable scales are provided to gauge tuck width and spacing.

Use either straight or decorative stitch setting.

ADDITIONAL FASHION DISCS

The following additional FASHION Discs are available for purchase at your local SINGER SEWING CENTER.



3 Solid Diamond



12 Domino



13 Fagoting



14 Comb



4 Solid Scallop



15 Thunderbird



16 Shag



17 Curlicue



18 Solid Pyramid



19 Block



20 Walls of Troy



21 Chevron

TO CLEAN THE MACHINE

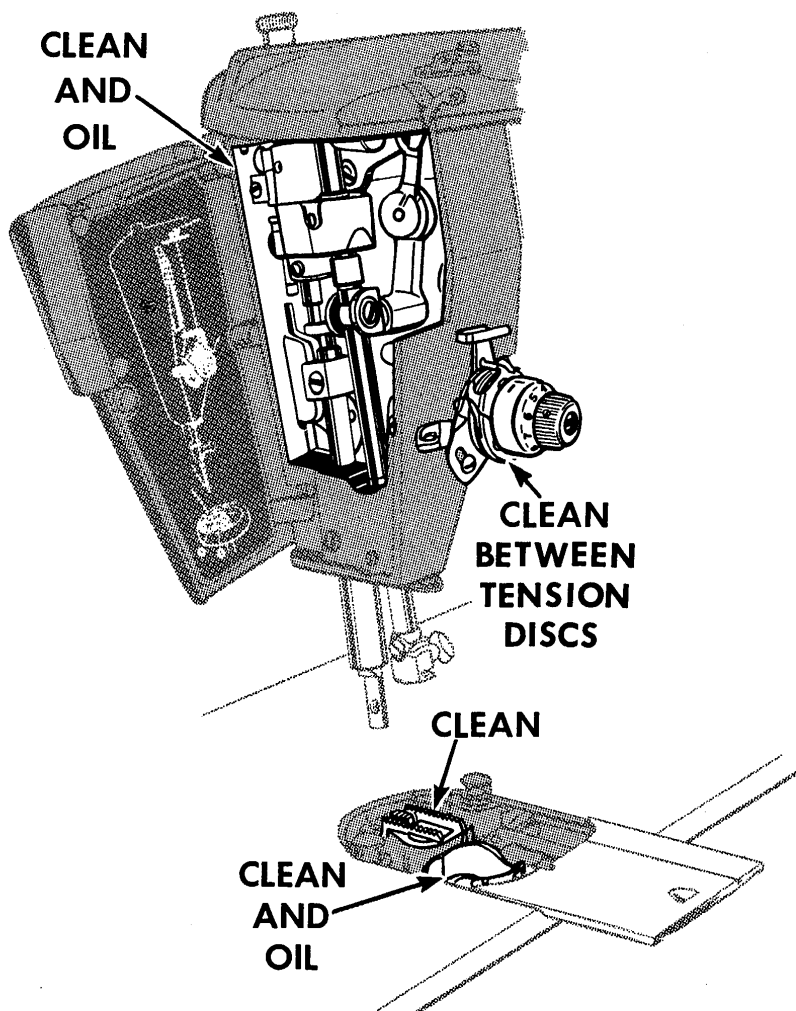

Your sewing machine was built to exacting standards of precision and workmanship. Its performance depends on the care and treatment it receives when in use and before storing it away.

When in regular use, the machine should be cleaned periodically to remove the lint and fluff which may have accumulated around the working parts. To clean the bobbin case area, see instructions for removing and replacing bobbin case on **pages 87 and 88**. Oil the machine after each cleaning as instructed on **pages 89, 90 and 91**.

If the machine is to be stored away for an indefinite period of time, a thorough brush-cleaning to remove all traces of lint and fluff, followed by swabbing of all exposed parts with a lint-free brush saturated with SINGER* Oil, is necessary to protect the machine against rust damage. The areas that should be cleaned and covered with a protective coat of oil are shown in the illustration at the left.

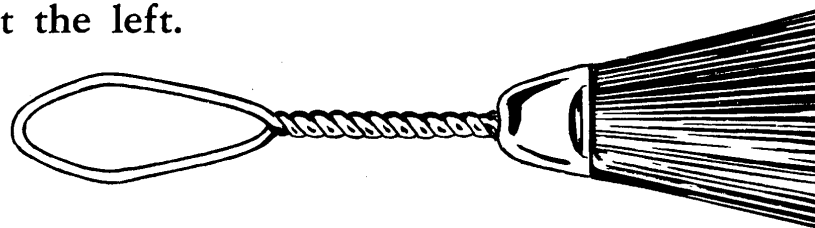

TO REMOVE AND REPLACE BOBBIN CASE

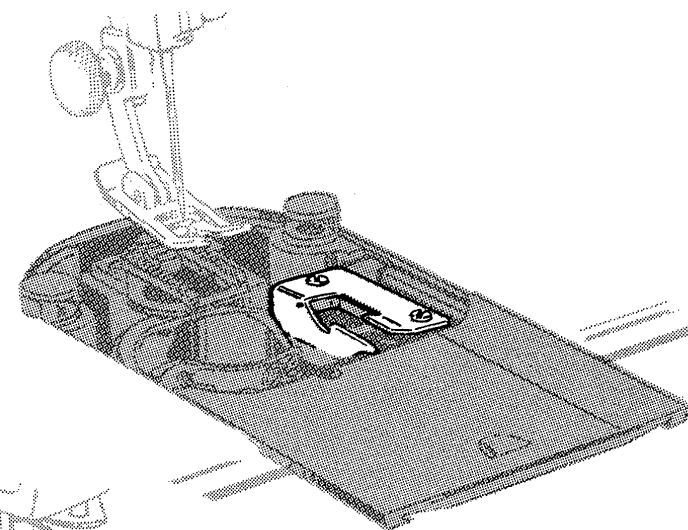
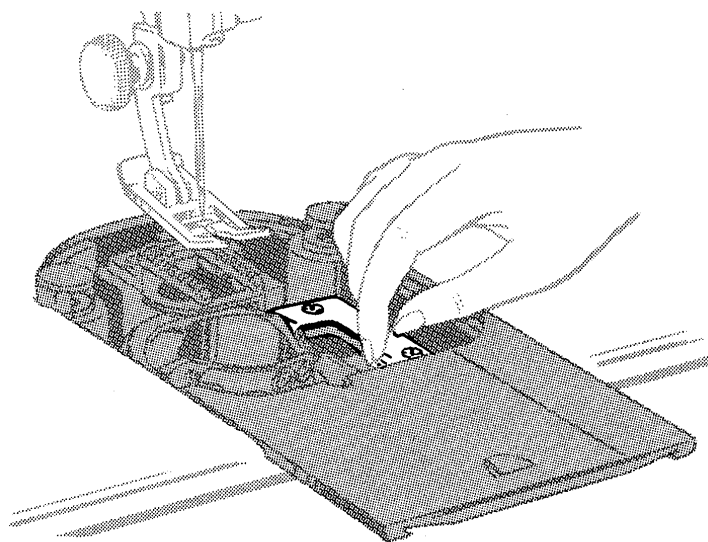

To clean hook raceway, remove bobbin case as follows:

1. Remove throat plate (see **page 17**) and open slide plate (see **page 10**).
2. Unlock bobbin case by lifting and pulling holder to right as shown.
3. Remove bobbin case from machine.
4. Remove all lint, fluff, loose thread ends or any other foreign matter which might clog the machine.

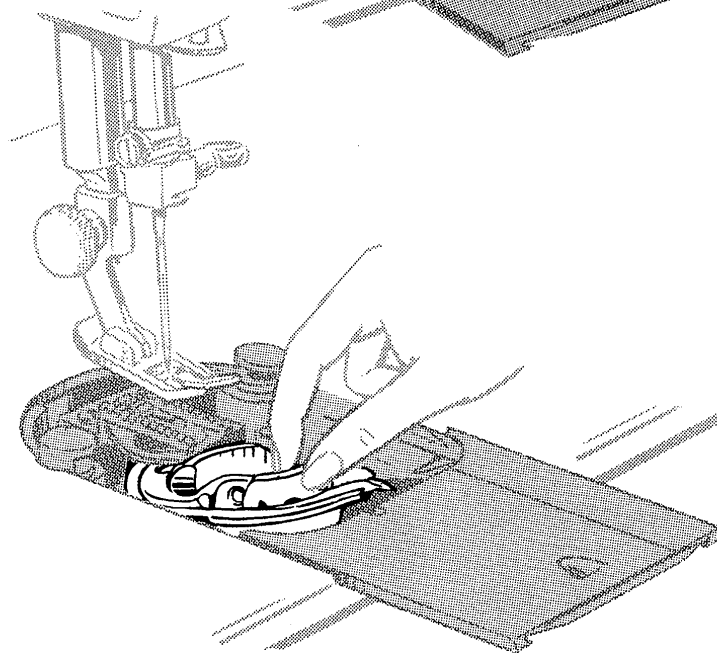

**POSITIONING
STUD**

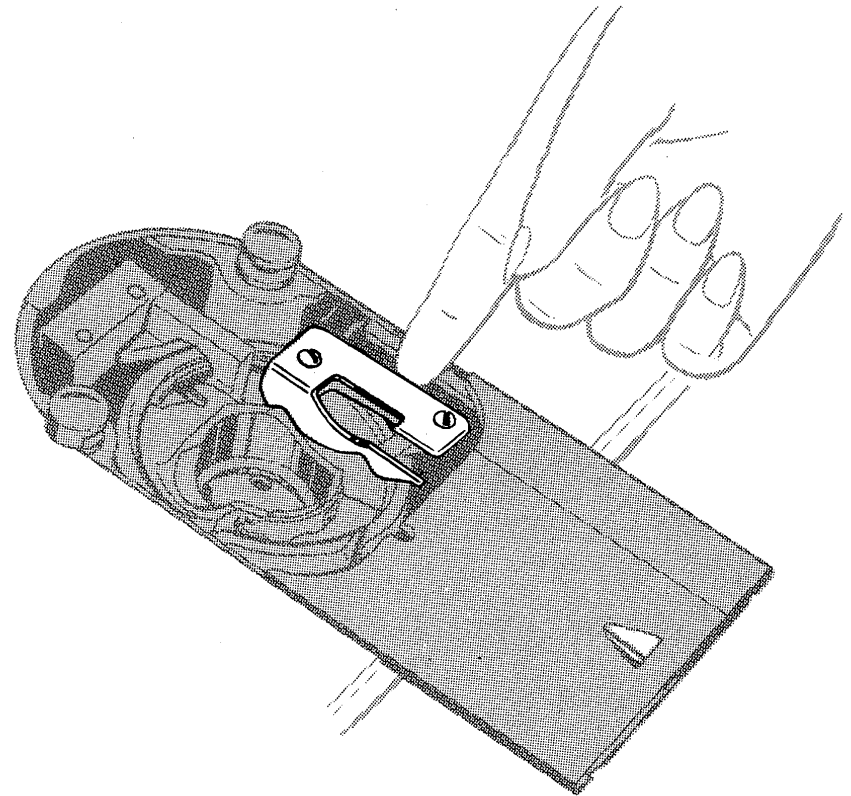
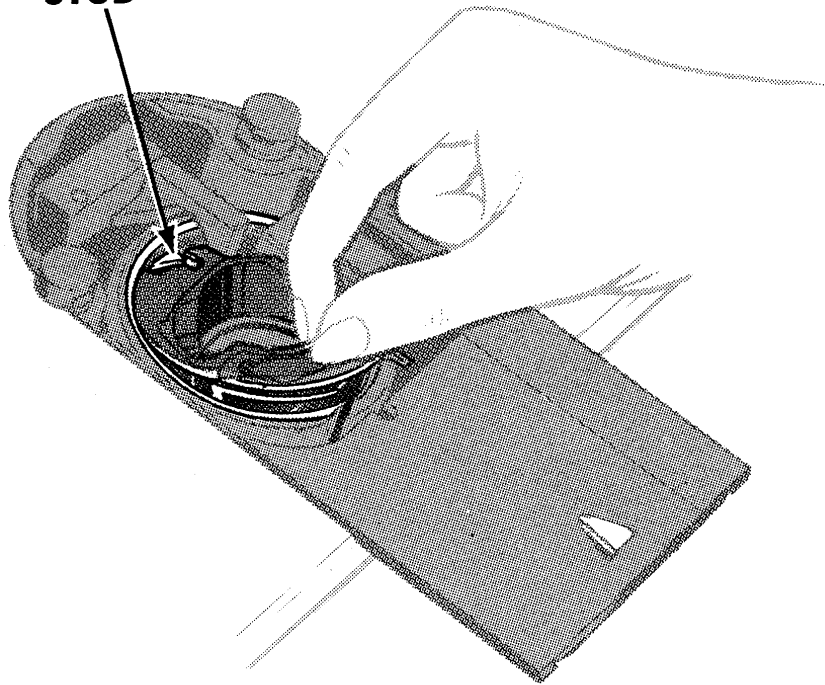

5. Replace bobbin case so that groove under tension spring fits on hook raceway and fork of case straddles positioning stud.
6. Push bobbin case holder to left as shown until it snaps down into lock position.
7. Close bed slide and replace throat plate.

TO LUBRICATE THE MACHINE

To keep your machine in top running condition, use SINGER* Oil and SINGER* Lubricant. Both are quality products especially prepared for sewing machines, and should always be used in the care of your 403.

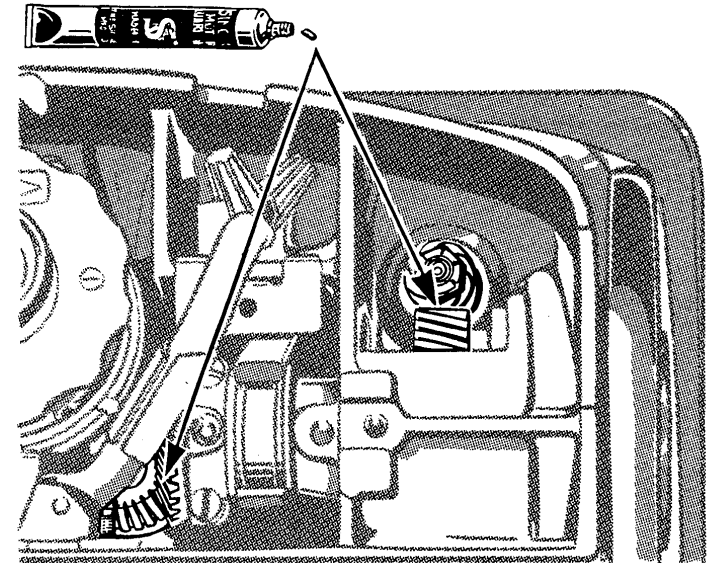
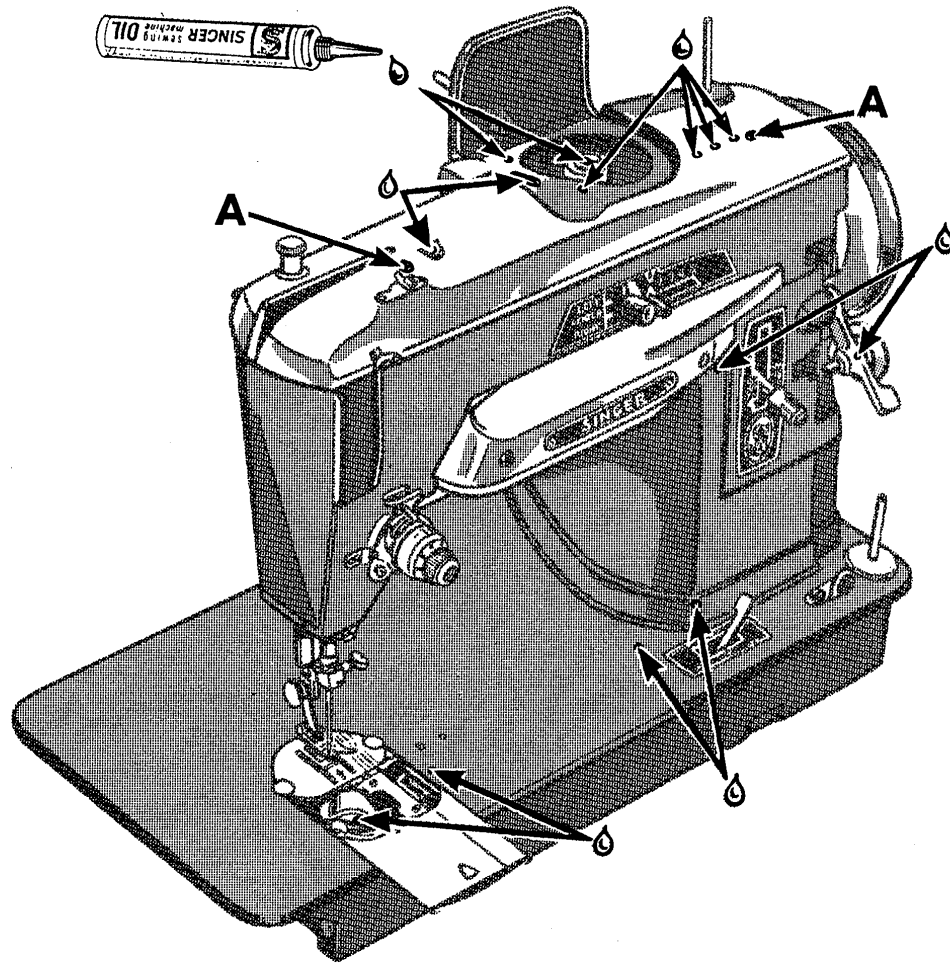

Clean the machine periodically as instructed on **page 86**.

Apply a drop of oil to each place indicated. Remove screws **A** and lift off arm top cover. Apply a small amount of lubricant to the gears as shown.

A tube of this lubricant can be purchased at your Singer Sewing Center.

NEVER APPLY OIL TO THESE GEARS.

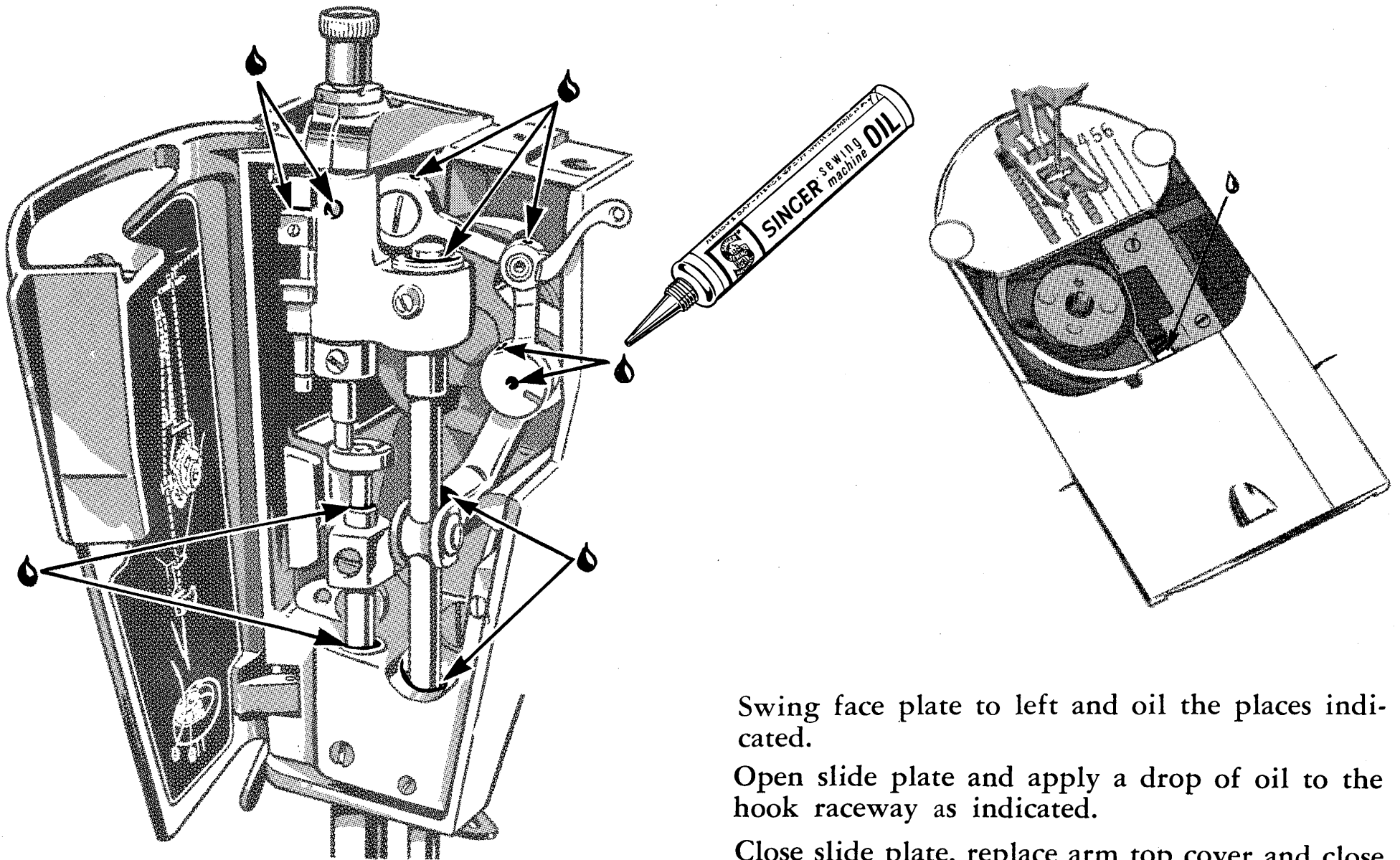

Swing face plate to left and oil the places indicated.

Open slide plate and apply a drop of oil to the hook raceway as indicated.

Close slide plate, replace arm top cover and close face plate.

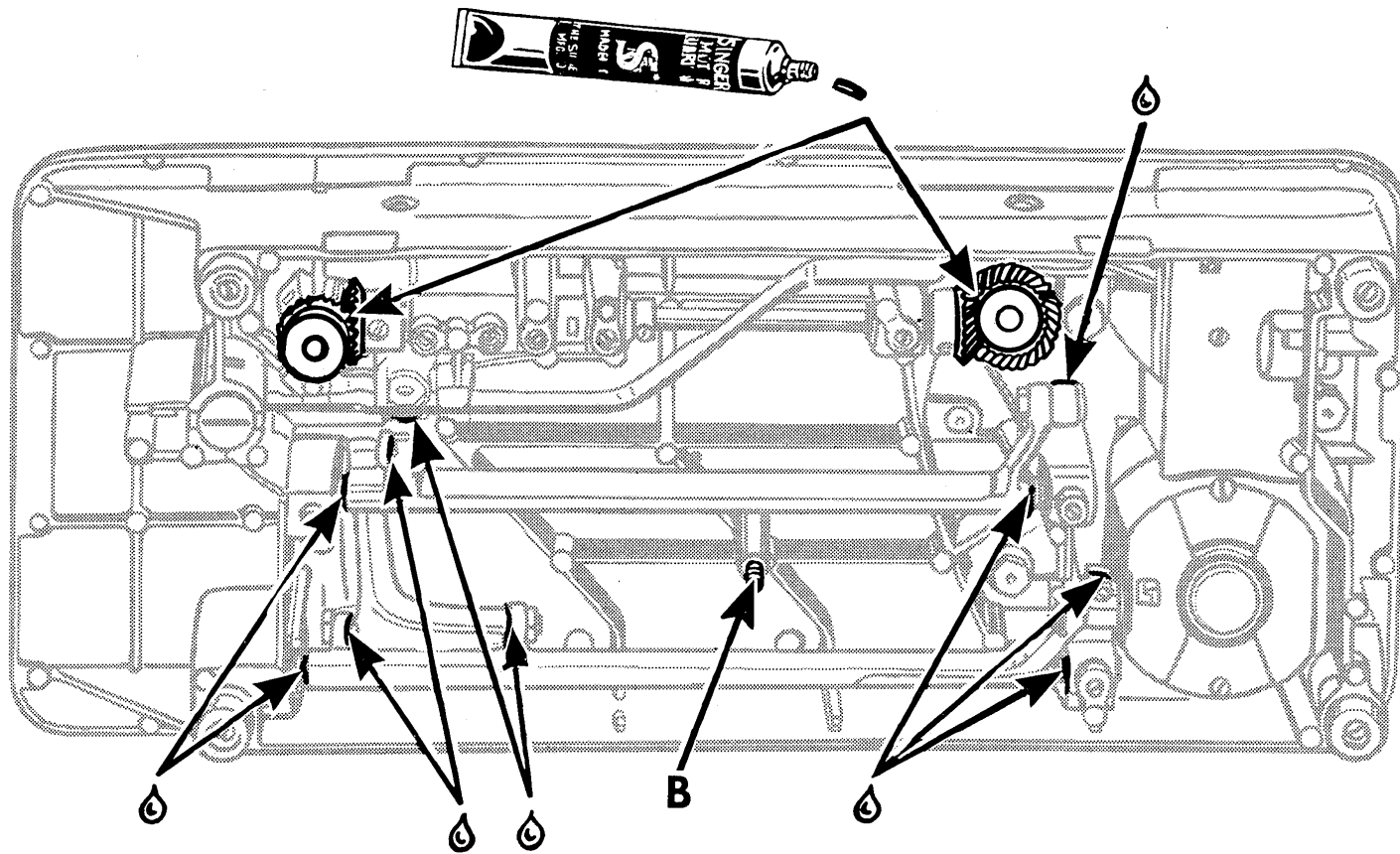

Tilt machine back and remove thumb nut from screw **B**, being careful not to lose felt washer, and remove cover from underside of machine.

Oil each of places indicated by arrows and occasionally apply a small quantity of lubricant to teeth of gears as shown.

Replace bottom cover.

THE MOTOR REQUIRES NO LUBRICATION.

ELECTRICAL INFORMATION

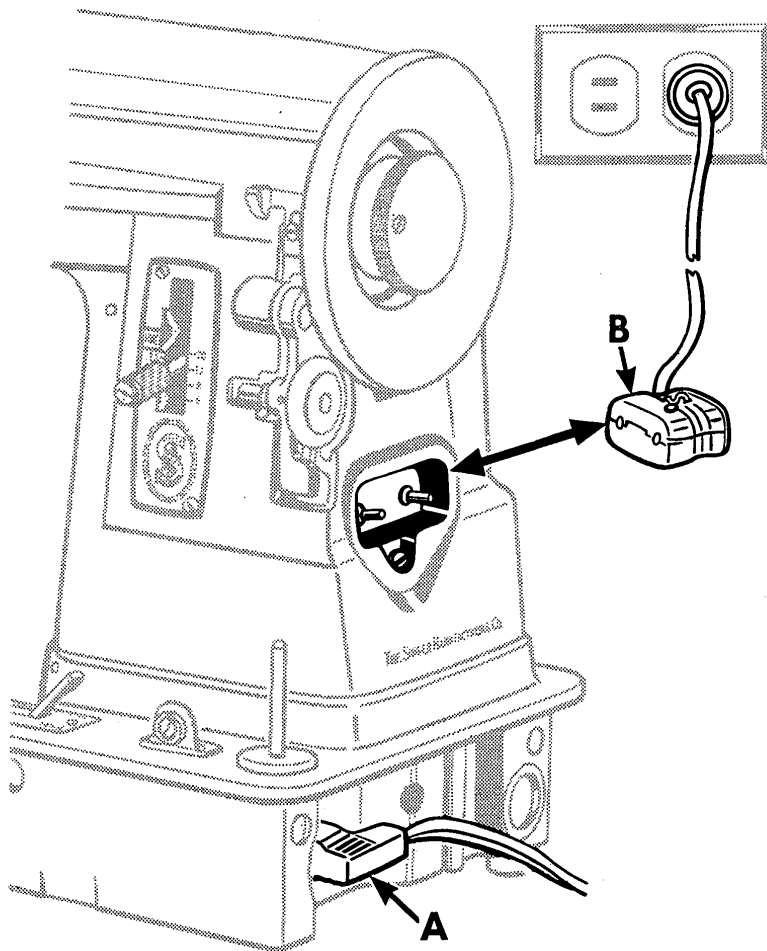

The **SINGER*** Electric Motor in your sewing machine will operate on direct current or on alternating current of 25 to 75 cycles at 110-120 volts. For voltages other than 110-120, special motors can be provided through your SINGER SEWING CENTER for any voltage between 50 and 145 to operate on either direct current or alternating current. Motors for 32 volts, direct current only, are also available.

Before Inserting Electric Plug, be sure that the voltage and the number of cycles stamped on the two-pin terminal block are within the range marked on your electric meter installed by your power company.

Electrical Connections for Machine. Push 2-pin terminal plug **A** on 2-pin terminal block at right end of bed.

Push 2-pin terminal plug **B** on 2-pin terminal block at right of machine and connect plug at other end of cord to electrical outlet.

Speed Controller. The speed of machine is regulated by amount of pressure on the pedal of the foot controller or the knee lever.

SINGER LIGHT

The light is turned "on" or "off" by the switch **F**.

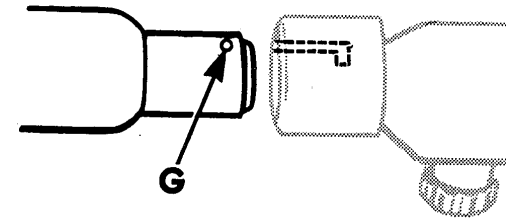
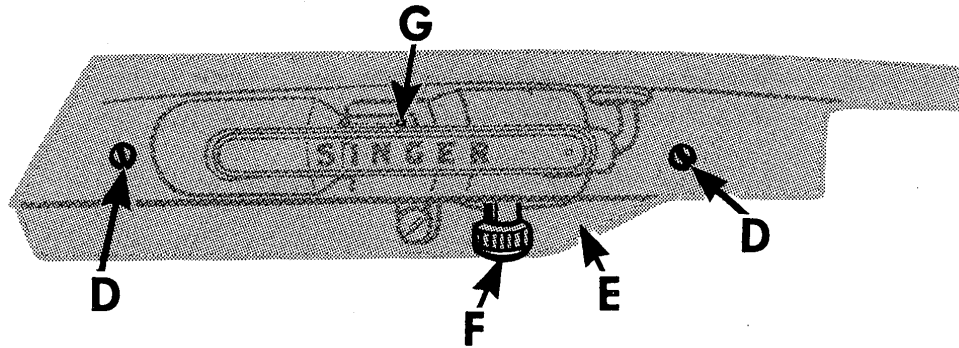

To Remove Bulb. Remove two screws **D** and lamp cover **E**. Do not attempt to unscrew bulb. Press it into socket and at same time turn bulb over in direction shown to unlock bulb pin **G**, then withdraw bulb.

To Replace Bulb. Press new bulb into socket with bulb pin **G** entering slot of socket and turn it over in direction shown to lock bulb pin **G** in position. Replace lamp cover **E** and securely fasten it in position with two screws **D**.

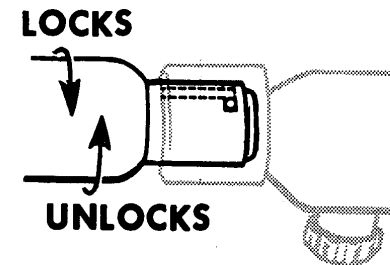

INDEX

	PAGE		PAGE
Applique	47-48	Cleaning the Machine	86-88
Attachments		Corded Applique	48
Button Sewing Foot	55-56	Corded Buttonholes	46
Foot Hemmer	72-74	Cording	
General Purpose Foot	57-62	Seams	71
Multi-Slotted Binder	75-76	Welting	70
Ruffler	77-80	Couching	54
Seam Guide	63-65	Darning, Free Motion Work	81
Special Purpose Foot	42-54	Darning and Embroidery Attachment	84
Zipper Foot	66-71	Darts	60-61
Bight Selector		Interfacing	61
Control of Width	33	Single Thread	60
Operation	15	Decorative Hems	74
Two-Needle Setting	39-40	Edge Stitcher	84
Binding	75-76	Elastic	
Blanket Binding, Replacing of	61	Application of Band	62
Blind Stitching		Girdle Mending	62
Hems	65	Electrical Information	92-93
Zipper Insertion	69	Motor	92
Bobbin		SINGER Light	93
Preparation for Stitching	21	Embroidery, Free Motion Work	83
Removing	10	Fabric, Thread, Needle and Stitch Length Chart	5
Thread Tension	27	Fabrics, Guiding and Supporting	24
Winding	8-9	FASHION Aids	
Bobbin Case		Darning and Embroidery Attachment	84
Removal and Replacement	87-88	Edge Stitcher	84
Threading	11	Gathering Foot	84
Border Designs	51-52	Tucker	84
Buttonholes	42-46	FASHION Discs	29-32
Corded	46	Additional	85
Button Sewing	55-56	Removal and Replacement of	32
Chart for Fabric, Thread, Needle and		Features	3
Stitch Length	5	Filler Cord, Threading of	46

INDEX (Continued)

	PAGE		PAGE
Finishes, Seam	59	Needle Position Selector	
Foot Hemmer	72-74	Operation of	14
Decorative Hems	74	Two-Needle Setting	40
Hemming with Lace	73	Zigzag Setting	34
Free Motion Work	81-83	Needle, Thread, Fabric and Stitch Length Chart	5
Darning	81	Needle Thread Tension	
Embroidery	83	Satin Stitching	36
Monograms	82	Straight Stitching	26
Gathering	78	Needle Threading	
Gathering Foot	84	Single	7
General Purpose Foot, Applications of	57-62	Two	38
Guiding and Supporting Fabric	24	Oiling	89-91
Hemming with Lace	73	Pleating	80
Hems		Prepare to Sew	21
Blind Stitched	65	Pressure Adjustments	25
Decorative	74	Principal Parts of Machine	12
Interfacing Darts	61	Removal and Replacement of Bobbin	10
Knit Fabric Seams	58	Removal and Replacement of Bobbin Case	87-88
Lace		Removal and Replacement of FASHION Discs	32
Applique	48	Removal and Replacement of Throat Plate	17
Edging and Insertion	54 and 73	Rent or Tear Mending	62
Length of Stitch, Regulating	13	Reverse Stitching	
Light Bulb, Replacement of	93	Application	22-23
Lubricating	89-91	Regulation	13
Mending	62	Ruffler	77-80
Monograms, Free Motion Work	82	Attaching Ruffle	79
Monograms and Motifs	49-50	Gathering	78
Motor	92	Pleating	80
Multi-Slotted Binder	75-76	Satin Stitching	
Needle Insertion	6 and 37	Stitch Length Adjustment	35
		Tension Adjustment	36
		Seam Finishes	59

INDEX (Continued)

	PAGE		PAGE
Seam Guide	63-65	Thread, Needle, Fabric and Stitch Length Chart	5
Blind Stitched Hems	65	Threading	
Seams	63	Bobbin Case	11
Top Stitching	64	Filler Cord	46
Seams		Single Needle	7
Corded	71	Two Needle	38
Flat Felled	58	Throat Plate	
Knit Fabric	58	Changing	17
Lingerie	57	Positions	16
Sheer Fabrics	53	Straight Stitch	20
Straight	22-23	Zigzag Stitch	28
Supporting and Guiding	24	Top Stitching	64
Sheer Fabric Seams	53	Tucker	84
SINGER Service	4	Two Needles	37-41
Single Thread Darts	60	Illustrations of Work	41
Special Purpose Foot, Applications of	42-54	Insertion	37
Stitch Length		Straight Stitching	39
Regulator	13	Threading	38
Satin Stitch Adjustment	35	Zigzag Stitching	40
Stitch Length, Fabric, Thread and Needle Chart	5	Welting	70
Stitch Patterns		Winding a Bobbin	8-9
Basic FASHION Discs	30-31	Zigzag Stitching	
Additional FASHION Discs	85	Control of Width	33
Straight Stitching	18-27	Equipment	28
Equipment and Settings	18-20	FASHION Discs	30-31
Seams	22-23	Needle Positions	34
Secondary Positions	19	Operation	29
Two Needles	39	Stitch Length Adjustment	35
Tear or Rent Mending	62	Tension Adjustment	36
Tension Adjustments		Two Needles	40
Bobbin Thread	27	Zipper Foot	66-71
Needle Thread	26	Welting and Corded Seams	70-71
Satin Stitching	36	Zipper Insertion	68-69

To all whom it may concern:

The improper placing or renewal of the trademark "**SINGER**" or any other of the trademarks of The Singer Manufacturing Company (all of which are duly Registered Trademarks) on any machine that has been repaired, rebuilt, reconditioned, or altered in any way whatsoever outside a SINGER factory or an authorized SINGER agency is forbidden.

For your protection

SINGER Sewing Machines are sold and serviced wherever you see the famous SINGER and Red "S" Trademarks. When your machine needs servicing call your SINGER SEWING CENTER to be sure of warranted SINGER parts and service. See address in the classified telephone directory.

S I N G E R S E W I N G M A C H I N E C O M P A N Y