

SINGER



327

T H E S I N G E R C O M P A N Y

**Form K6601
(664)**

Printed in Great Britain

SINGER*

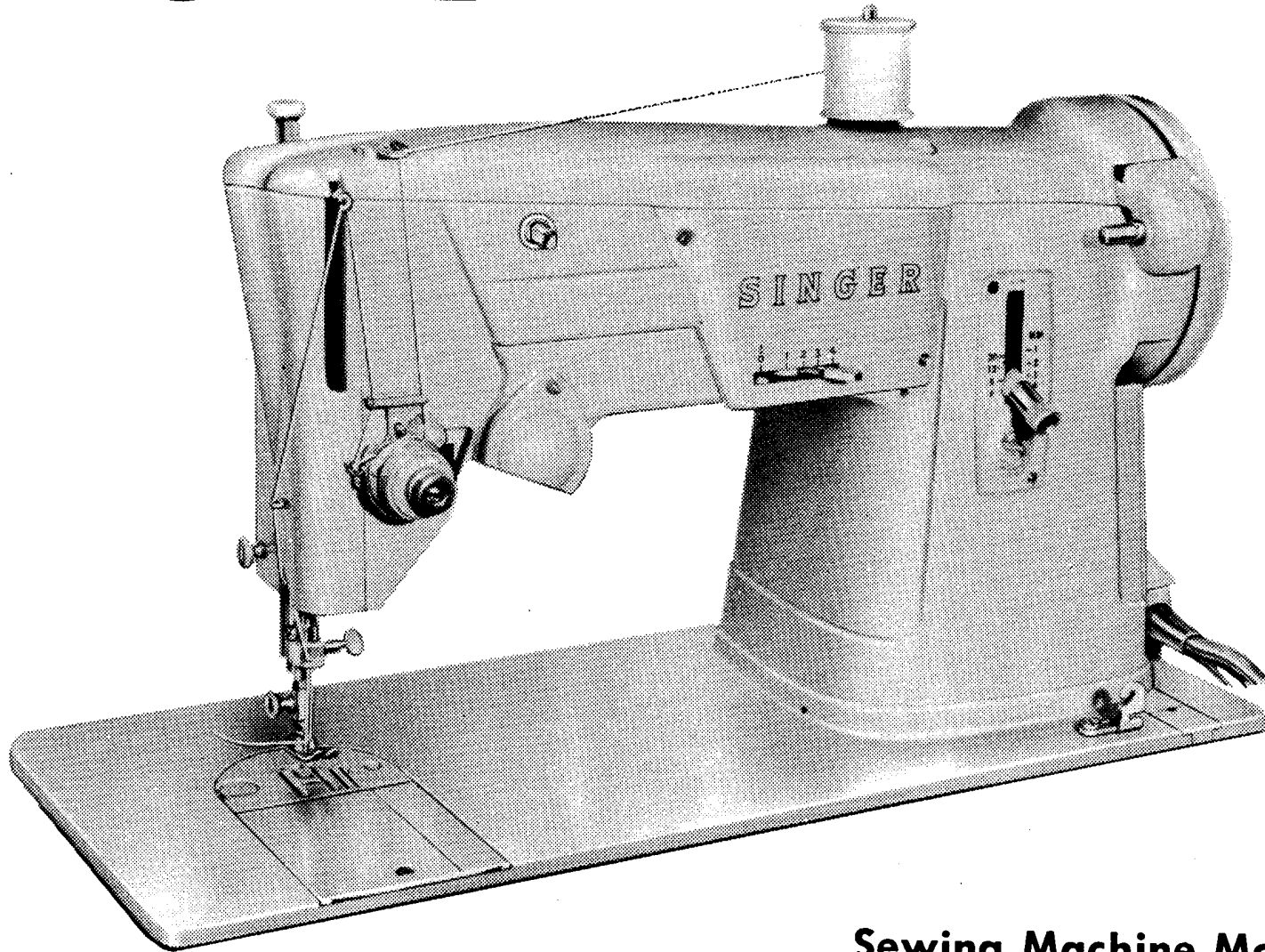

Sewing Machine Model 327

*A Trademark of THE SINGER COMPANY

AS THE OWNER OF THE SINGER* 327

. . . you have a dependable, smooth running zigzag sewing machine that is outstanding in its simplicity of operation. You can overcast a seam, make a buttonhole or satin stitch a decorative applique. Then, switch instantly to straight stitching for seaming, machine basting or darning.

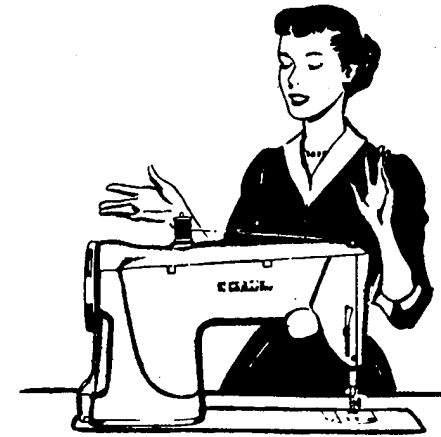

Outstanding features include

- "DROP-IN" BOBBIN . . . located in *front* of the needle.
- SINGLE TURN TENSION . . . calibrated for accurate adjustment.
- CLAMP-TYPE THROAT PLATE . . . easy to remove.
- ALUMINUM CONSTRUCTION . . . lightweight and durable.

SINGER SERVICE

Wherever you go you will find expert, dependable SINGER* Service close at hand. Look under SINGER SEWING MACHINE COMPANY, in the phone book, for the address of the nearest SINGER SEWING CENTER. Here, you can obtain the services of a trained SINGER repair man, warranted SINGER parts, sewing information and services, sewing aids and notions.

Copyright Under International Copyright Union

PRINCIPAL PARTS OF MACHINE 327

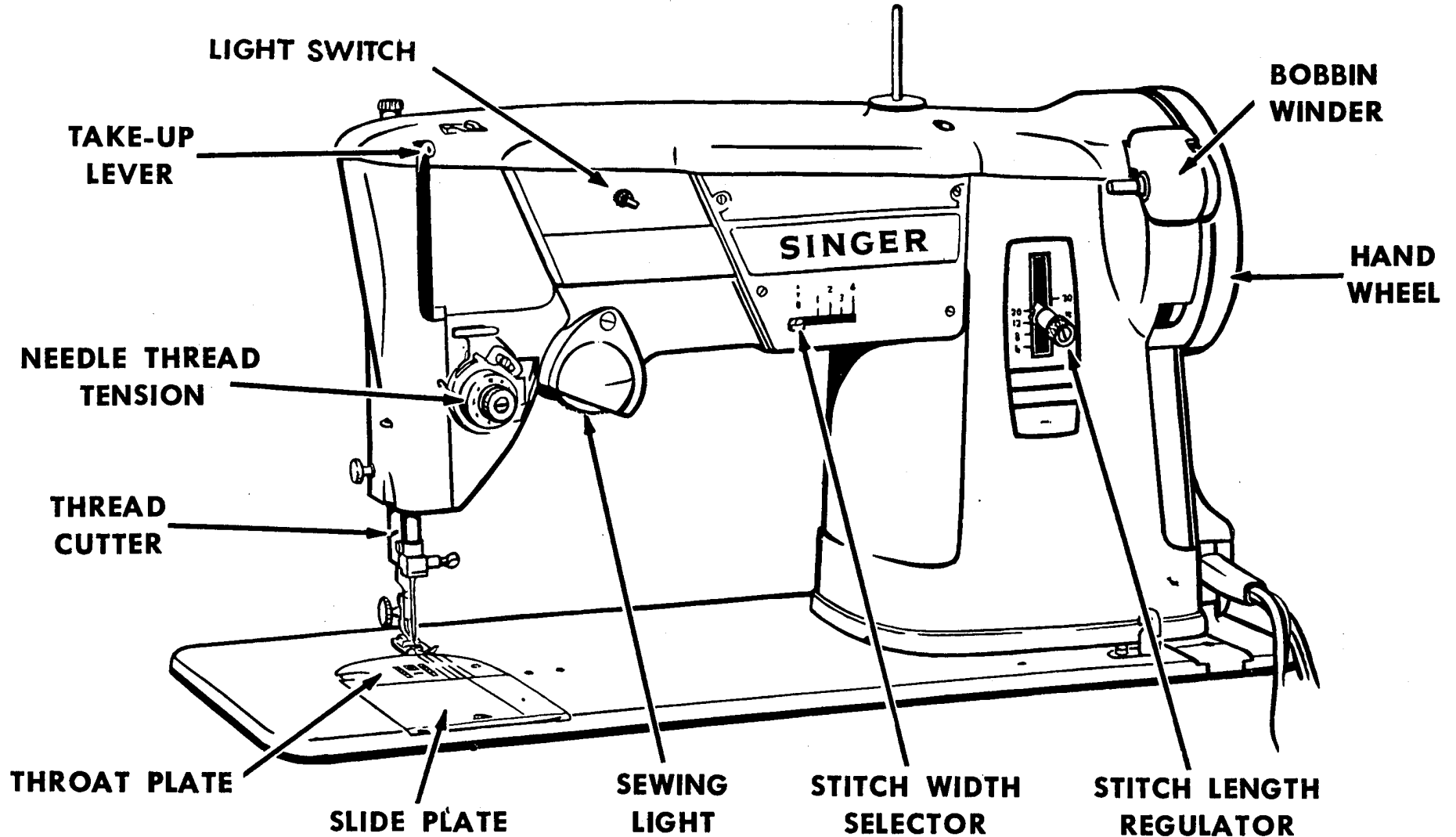

FABRIC, THREAD, NEEDLE AND STITCH LENGTH CHART

FABRICS	THREAD SIZES	NEEDLE SIZES	MACHINE STITCHES PER INCH STRAIGHT STITCHING
DELICATE —tulle, chiffon, fine lace, silk organdy, fine tricot	Fine Mercerized 100 to 150 Cotton Synthetic Thread	9	15 to 20
LIGHTWEIGHT —batiste, organdy, jersey, voile, taffeta, silk crepe, plastic film	50 Mercerized 80 to 100 Cotton A Silk Synthetic Thread	11	12 to 15 (8 to 10 for plastic)
MEDIUM WEIGHT —gingham, percale, pique, linen, chintz, faille, satin, fine corduroy, suitings	50 Mercerized 60 to 80 Cotton A Silk Synthetic Thread	14	12 to 15
MEDIUM HEAVY —gabardine, tweed, sail-cloth, denim, coatings, drapery fabrics	Heavy Duty Merc. 40 to 60 Cotton	16	10 to 12
HEAVY —overcoatings, dungaree, upholstery fabrics, canvas	Heavy Duty Merc. 24 to 40 Cotton	18	8 to 10

NEEDLES AND THREAD

This machine uses needle, Catalog 2020 (15 x 1). Sizes 9, 11, 14, 16 and 18.

For perfect stitching, select correct needle and thread to correspond with fabric according to table on **page 4**. Be sure to use like threads for both needle and bobbin.

NEEDLE INSERTION

- Raise needle bar to highest point by turning hand wheel toward you.
- Loosen needle clamp screw.
- Insert needle upward into clamp as far as it will go, with flat side of needle to back and **long groove toward you**.
- Tighten needle clamp screw.

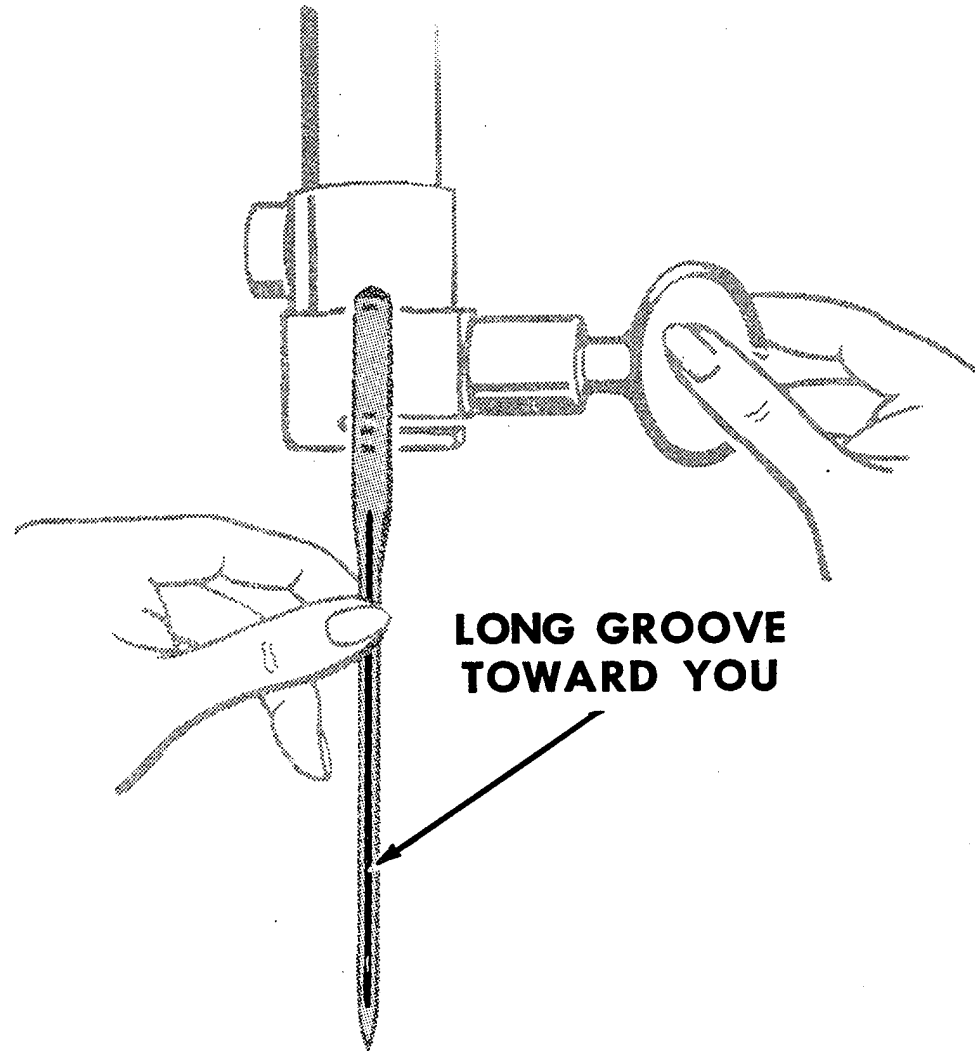

WINDING THE BOBBIN

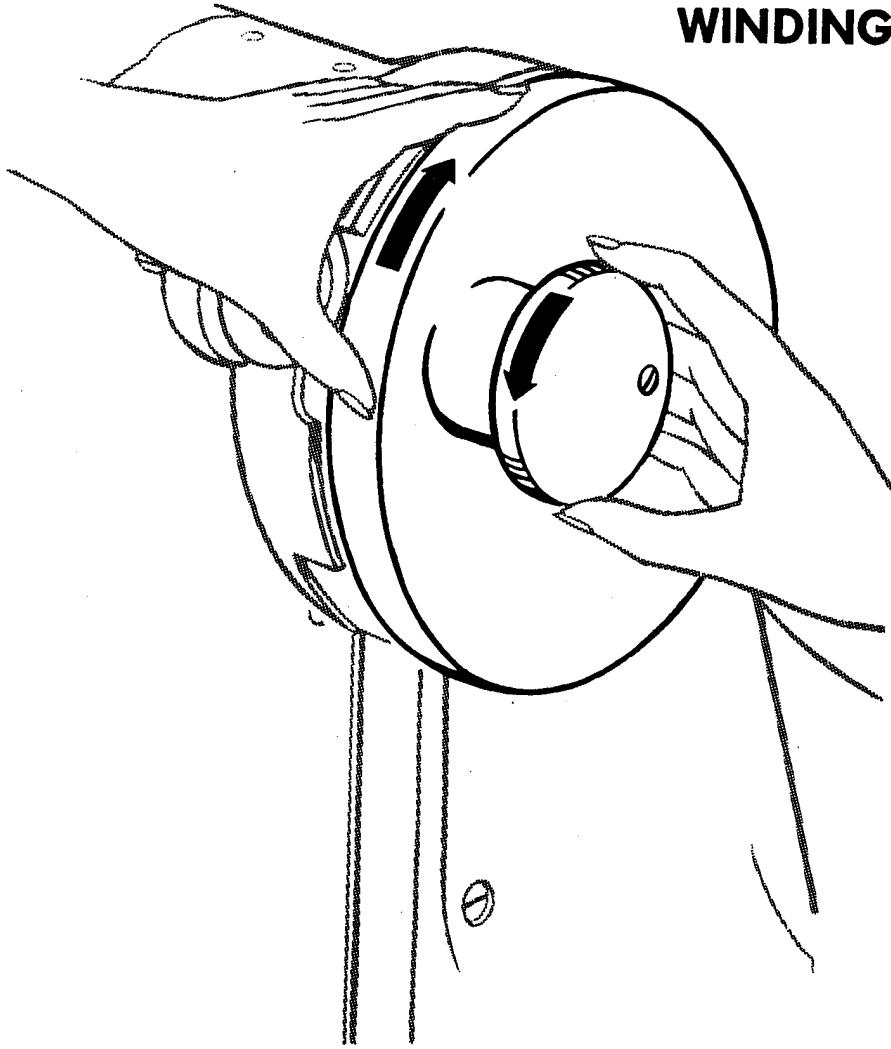

- Loosen stop motion screw with right hand.

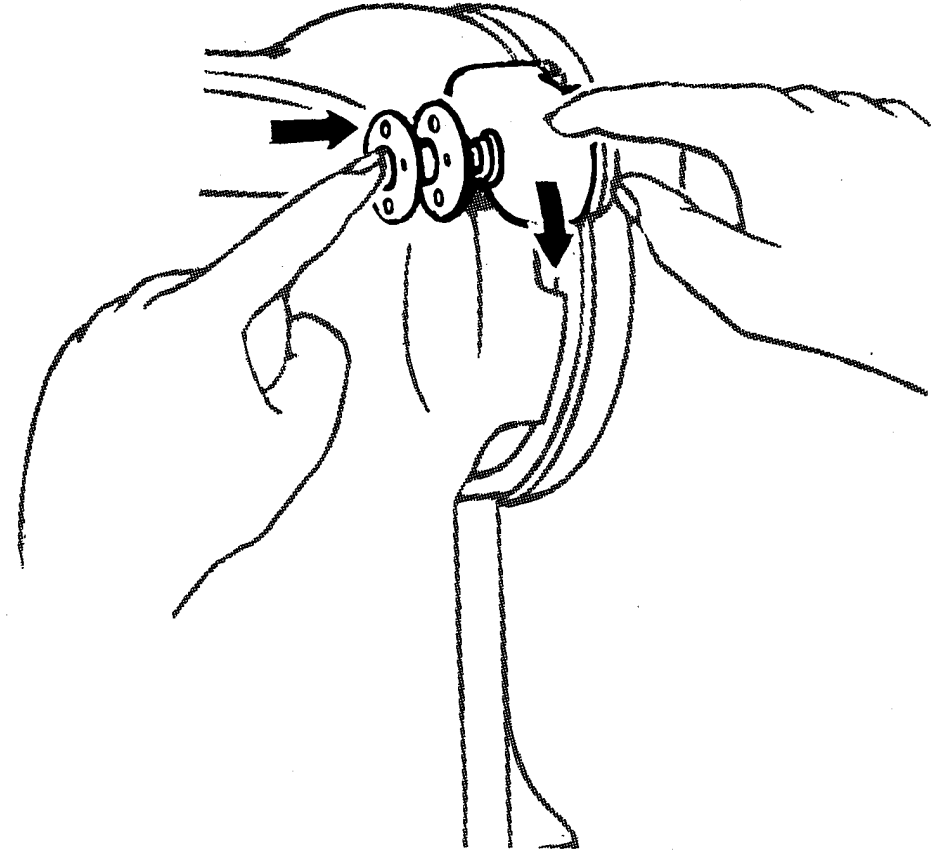

- Place empty bobbin on spindle.
- Press bobbin winder down against hand wheel.

WINDING THE BOBBIN (Cont'd)

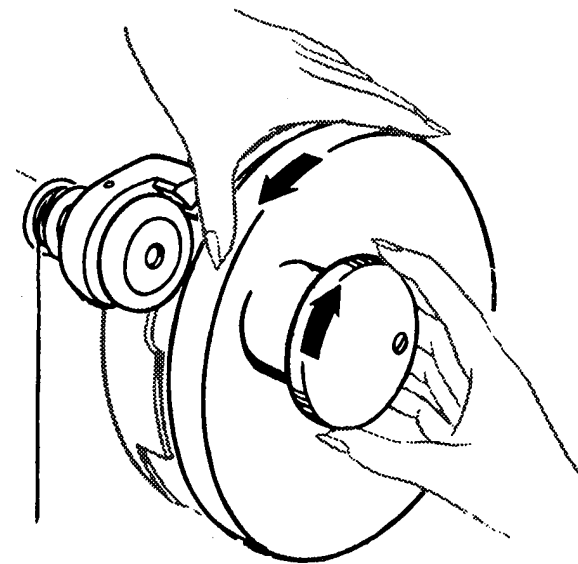
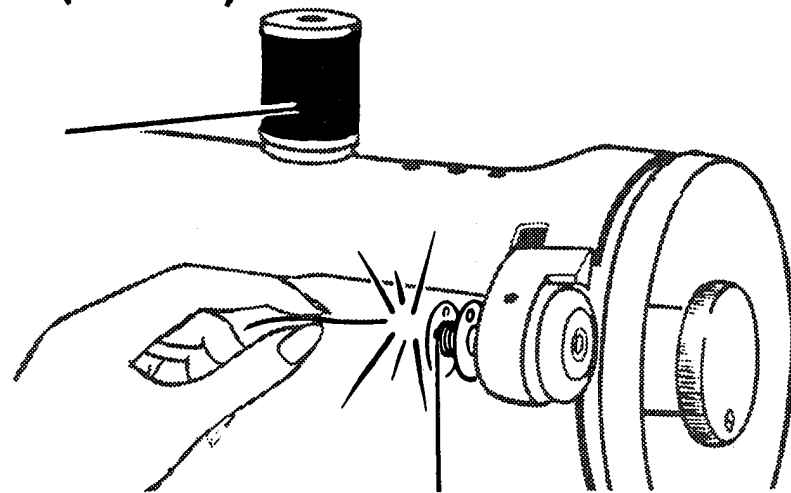
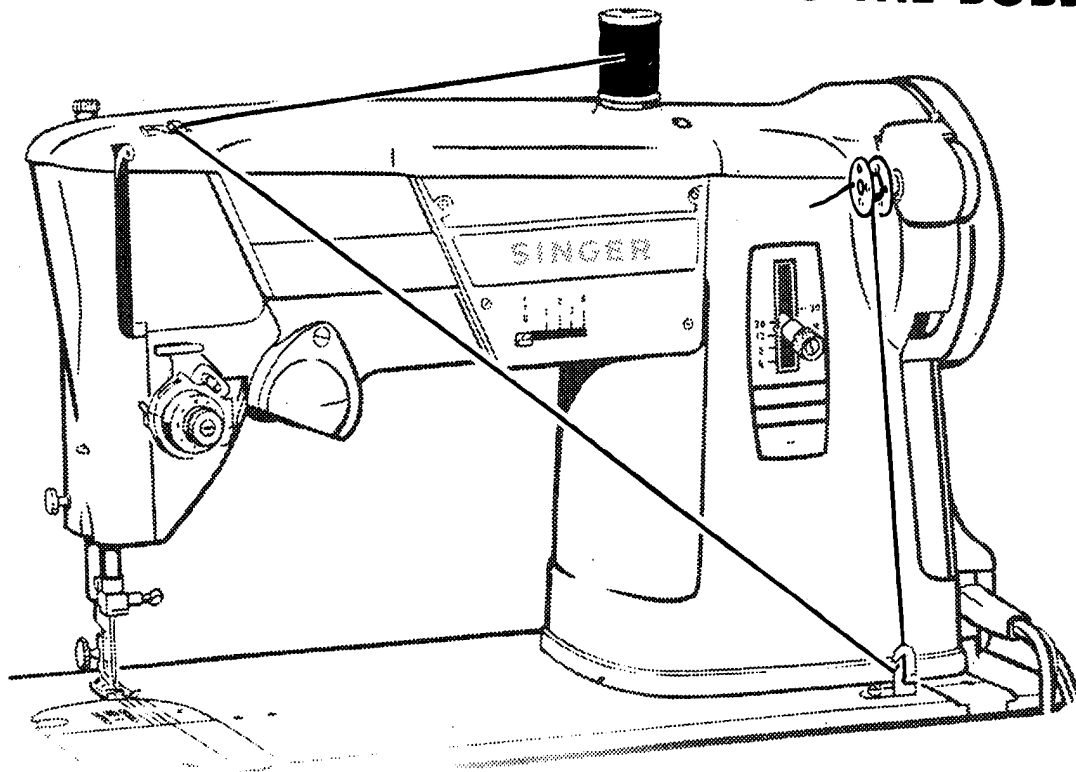

- Lead thread through guides and small hole in left side of bobbin as shown above.
- Hold thread end and start machine. (Cut off end of thread after a few turns.)
- When bobbin is full, stop machine.
- Lift bobbin winder away from hand wheel and remove bobbin.
- Tighten stop motion screw.

THREADING THE BOBBIN CASE

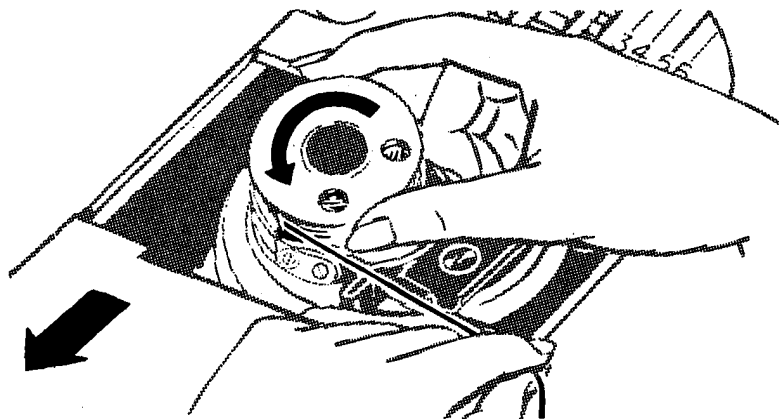

- Open slide plate. Insert bobbin with thread leading off as shown.

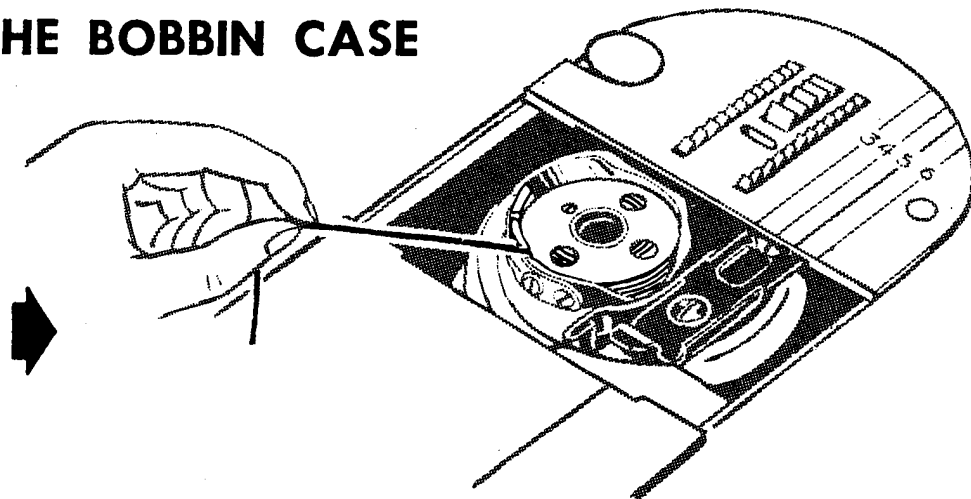

- Place bobbin in case.
- Lead thread into slot and under spring.

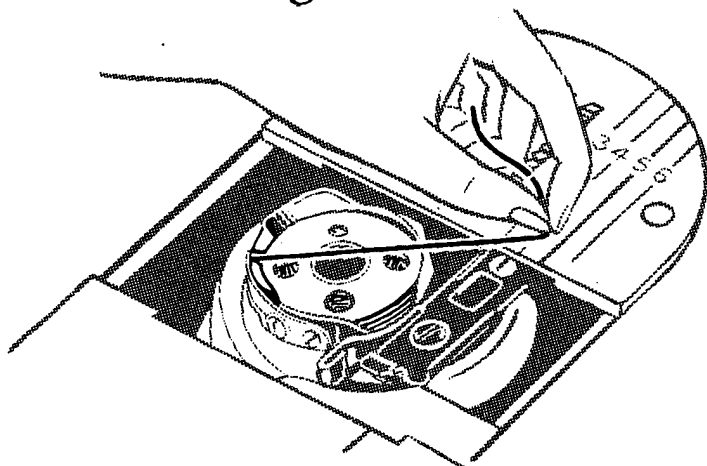

- Draw thread into notch at end of spring; pull about 3 inches of thread across bobbin.

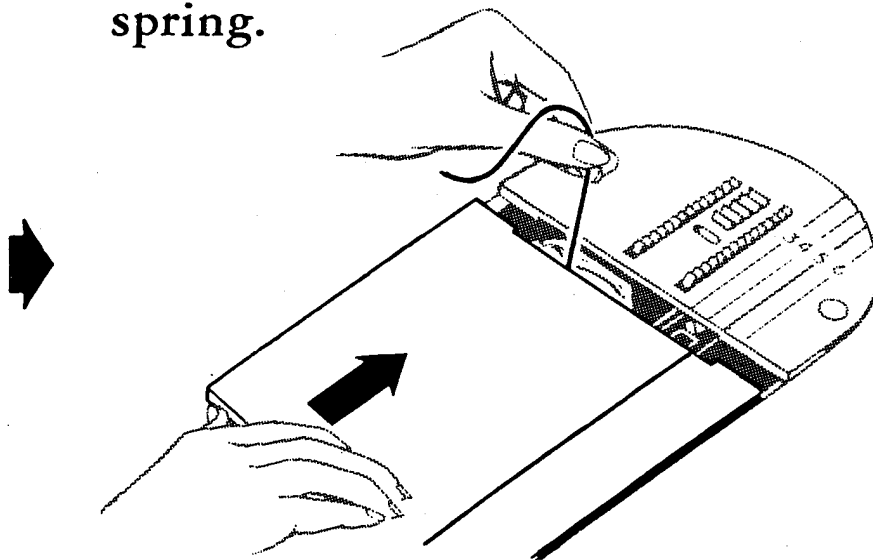

- Close slide plate.

UPPER THREADING

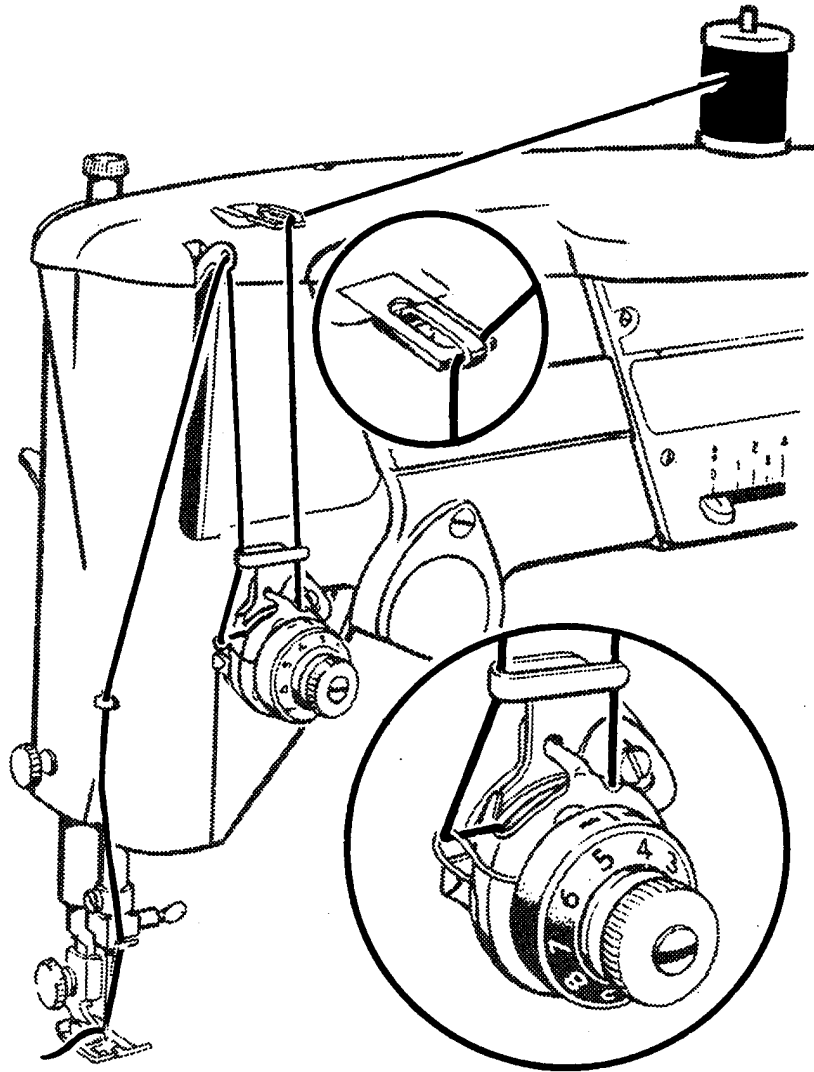

- Raise take-up lever to highest point.
- Lead thread through threading points shown.
- Draw sufficient thread through eye of needle with which to start sewing.

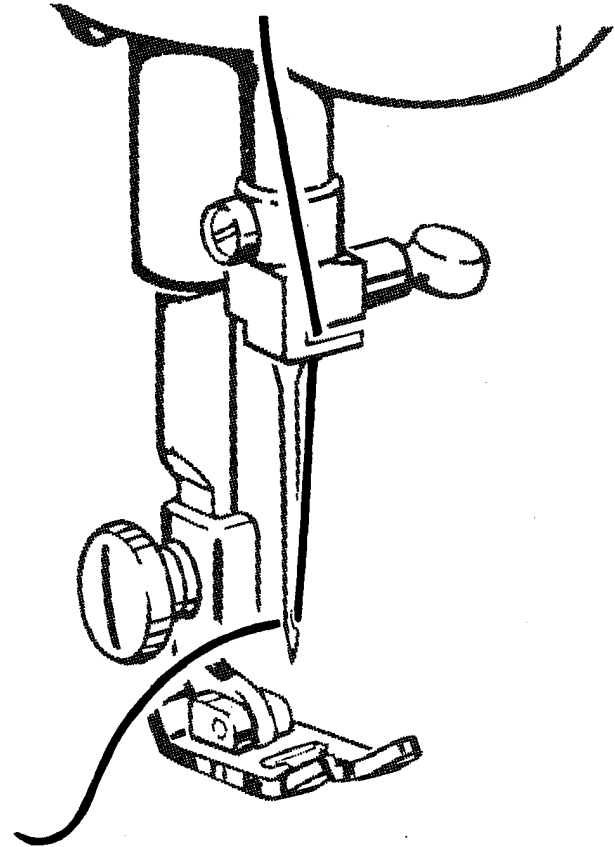

PREPARING TO SEW

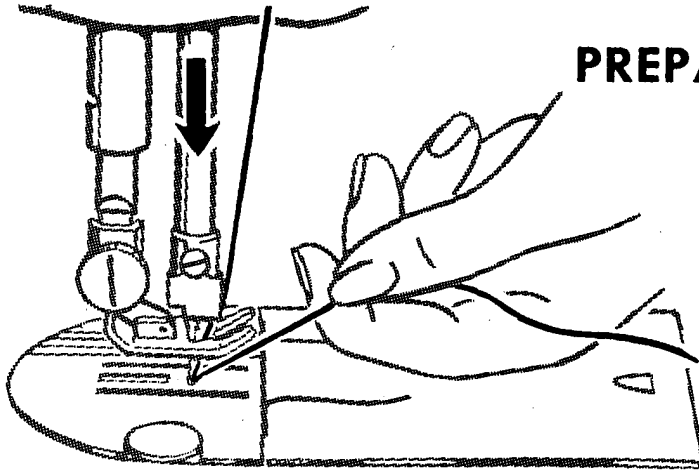

- Hold needle thread lightly with left hand.

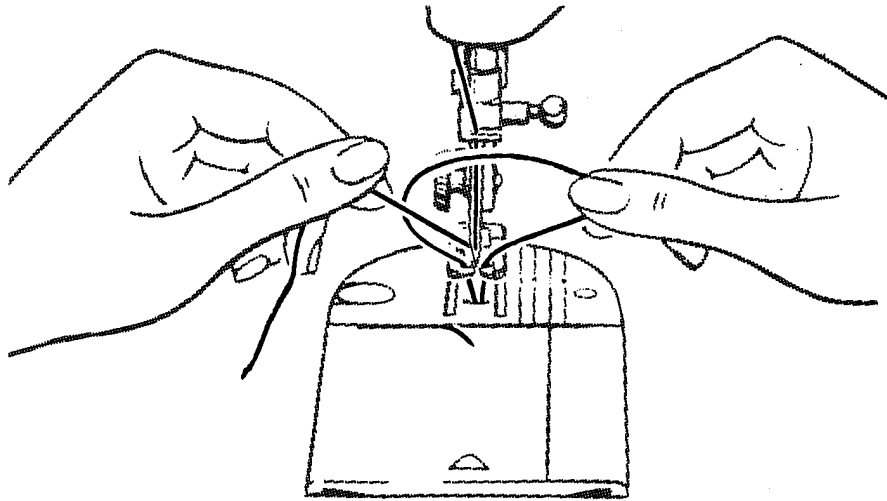

- Pull end of bobbin thread up through throat plate.

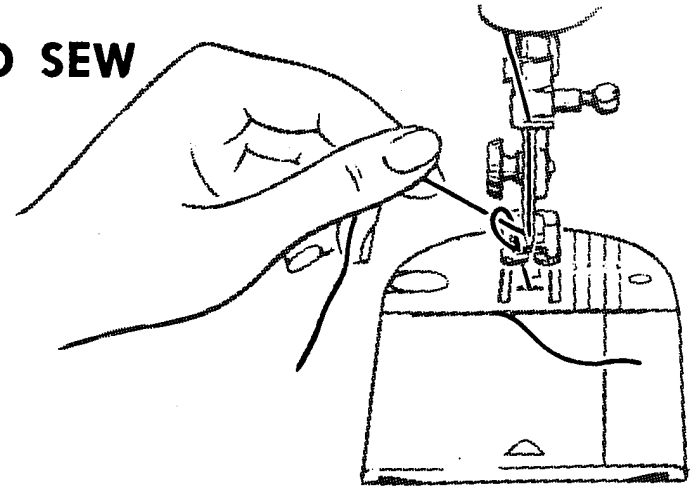

- Turn hand wheel so that needle enters plate and brings up bobbin thread.

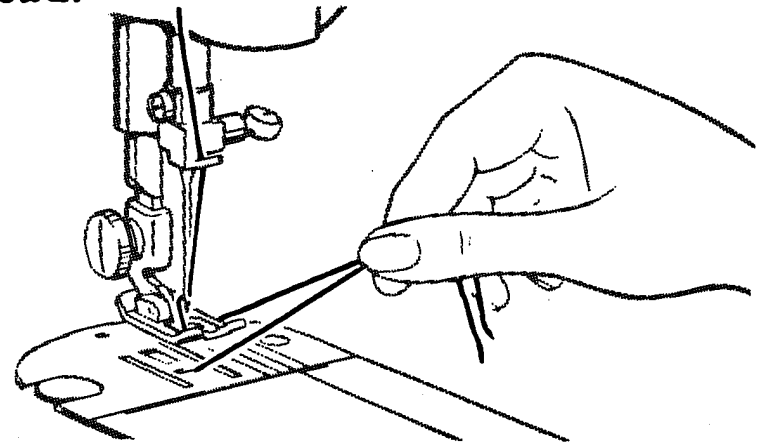

- Place both needle and bobbin threads diagonally under presser foot.

STITCH LENGTH REGULATOR

The numerals on the indicator represent the number of stitches per inch.

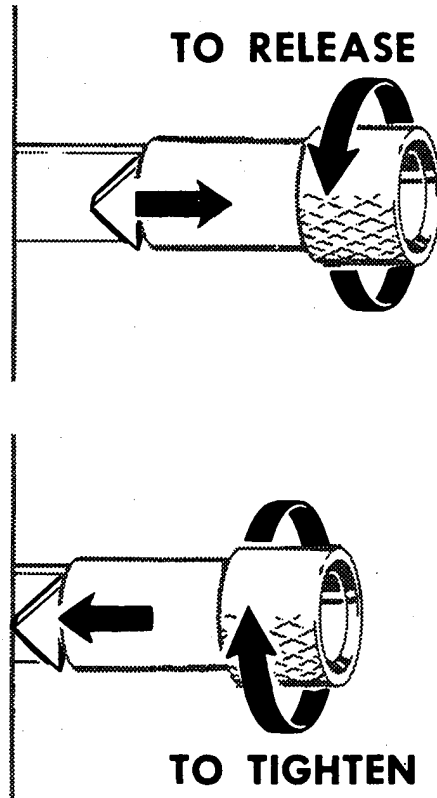
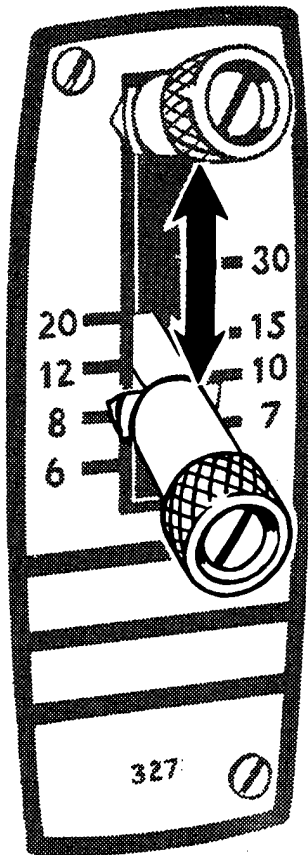

To set stitch length

- Release pointer by turning thumb nut to the left.
- Position lever for desired stitch length (the higher the number, the shorter the stitch length).
- Tighten pointer against indicator plate by turning thumb nut to the right.

Once the pointer has been tightened against the plate, reverse stitching is accomplished by raising the lever to its highest point.

To adjust stitch length for zigzag satin stitching

- Position lever midway between settings 20 and 30.
- Test setting by stitching on a scrap of the fabric to be used for the work.
- Move lever **up** toward 30 to close stitches; move lever **down** toward 20 to open stitches.

STRAIGHT AND ZIGZAG STITCHING

SELECTOR SETTINGS

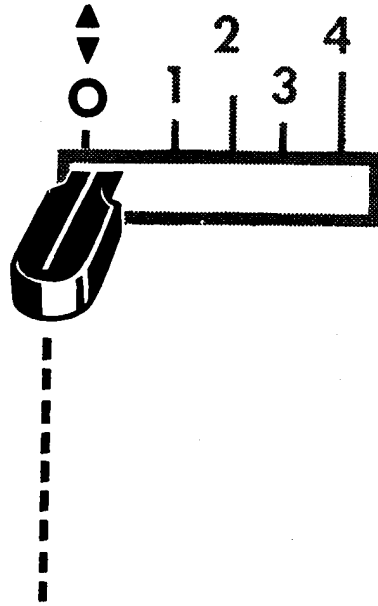

STRAIGHT STITCH SETTING
SELECTOR: 0

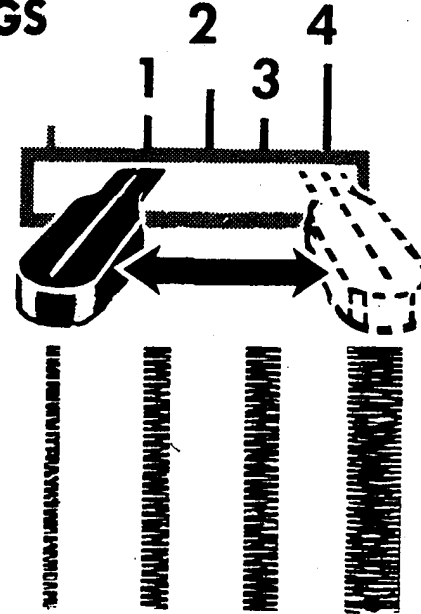

ZIGZAG STITCH SETTINGS
SELECTOR: 1 TO 4

The stitch width selector regulates the swing of the needle from a straight position 0 to a maximum zigzag width 4 ($5/32$ inch).

To position, slide selector to desired setting. As the lever is moved to the right the width of the zigzag stitch is increased. Settings of 1 thru 4 are indicated but intermediate settings may also be used.

To avoid damage to needle and fabric, do not make any selector adjustments with the needle in the fabric.

PRESSURE ADJUSTMENTS

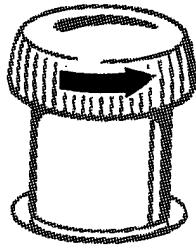
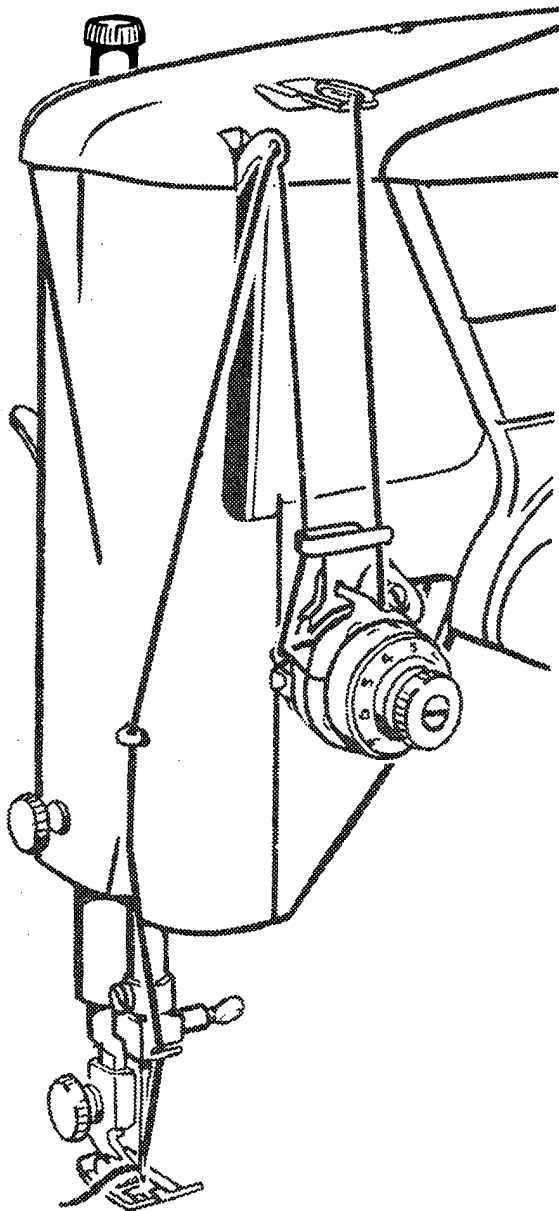

Decrease

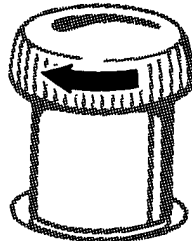

Increase

- To decrease pressure, turn thumb screw upward.
- To increase pressure, turn thumb screw downward.

Smooth, even handling of several thicknesses of fabric results when pressure is correctly regulated.

Surface finish, as well as the weight and texture of the fabric, must be considered in determining the amount of pressure needed.

Adjustment of the thumb screw regulates the amount of pressure exerted on the material while it is being stitched.

Too light a pressure will result in irregular feeding which affects both quality of stitch and evenness of seams.

Too heavy a pressure not only affects stitch and seam quality but will mar smooth surfaces and pile fabrics.

NEEDLE THREAD TENSION

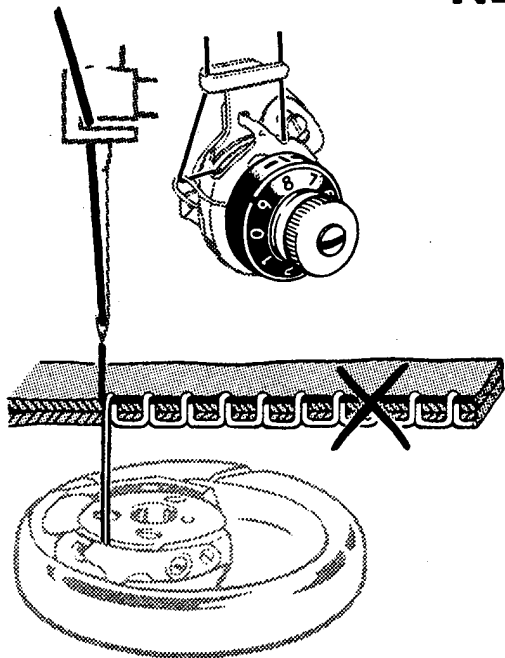

Needle thread tension too tight—correct by setting dial to lower number.

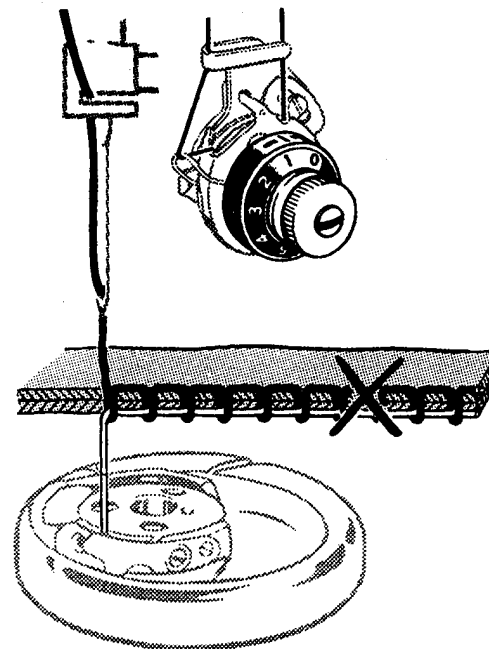
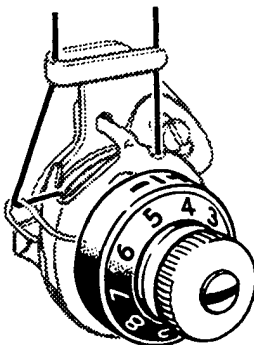

Needle thread tension too loose—correct by setting dial to higher number.



A perfectly locked stitch results with upper and lower tensions balanced so that needle and bobbin threads are drawn equally into fabric.

BOBBIN THREAD TENSION

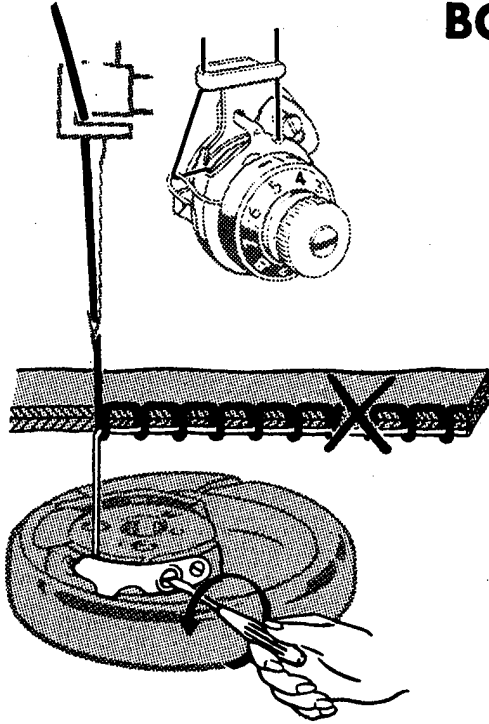

**Bobbin thread tension too tight
—correct by turning screw counterclockwise.**

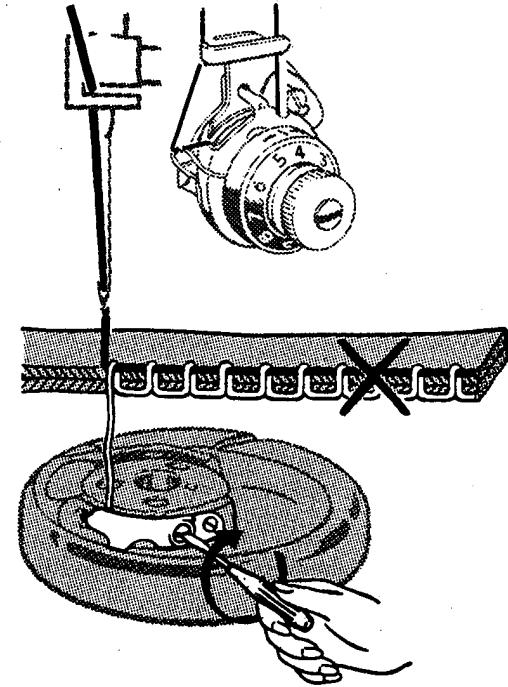

**Bobbin thread tension too loose
—correct by turning screw clockwise.**

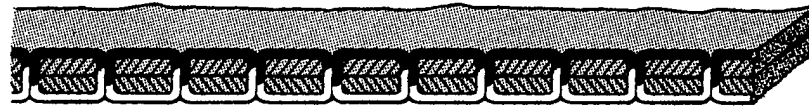

A perfectly locked stitch results with upper and lower tensions balanced so that needle and bobbin threads are drawn equally into fabric.

TENSION ADJUSTMENT FOR SATIN STITCHING

Satin stitching requires lighter needle thread tension than straight stitching or open zigzag stitching. The wider the satin stitching the lighter the tension required.

Wide satin stitching, Stitch Width Selector at 4, requires least amount of tension. For narrower satin stitching slightly more tension should be used.

To determine correct tension setting, a test sample should be made on self-fabric. A properly balanced satin stitch should lie flat across the material.

Some soft fabrics may require addition of a backing to insure good stitching results. Crisp organdy and lawn are suitable for this purpose.

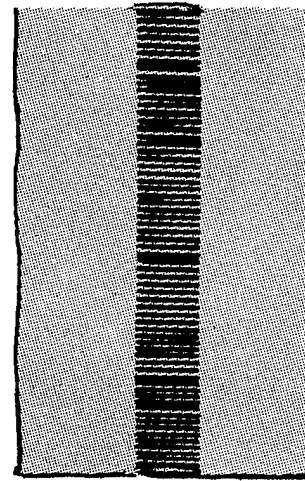
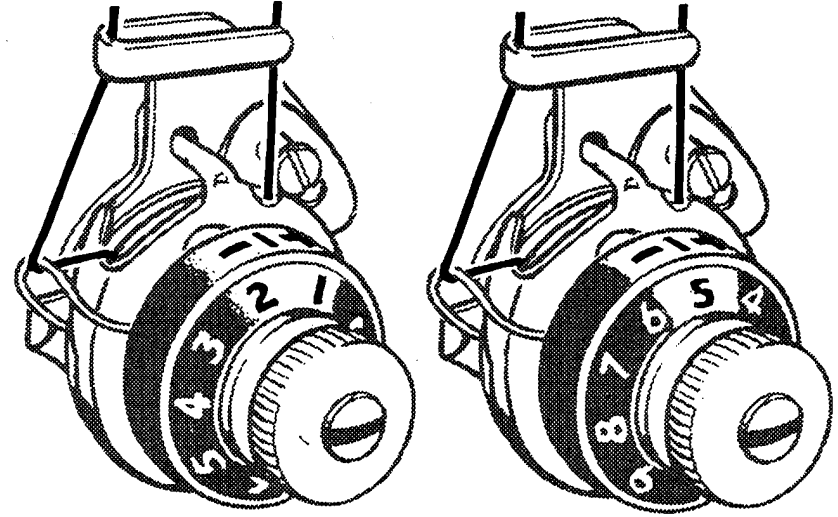

Correct

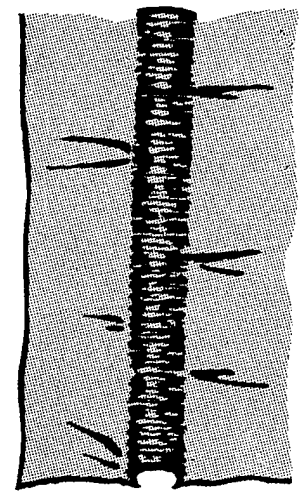

Incorrect

ZIGZAG APPLICATIONS

LINGERIE SEAMS

Dainty lingerie seams are made durable with zigzag stitching. After straight stitching seam on wrong side, press both seam allowances in same direction. From right side, top stitch with a fine zigzag setting ($1\frac{1}{2}$ width), letting needle alternately enter seam line and seam thicknesses. This finish is particularly suitable for bias seams.

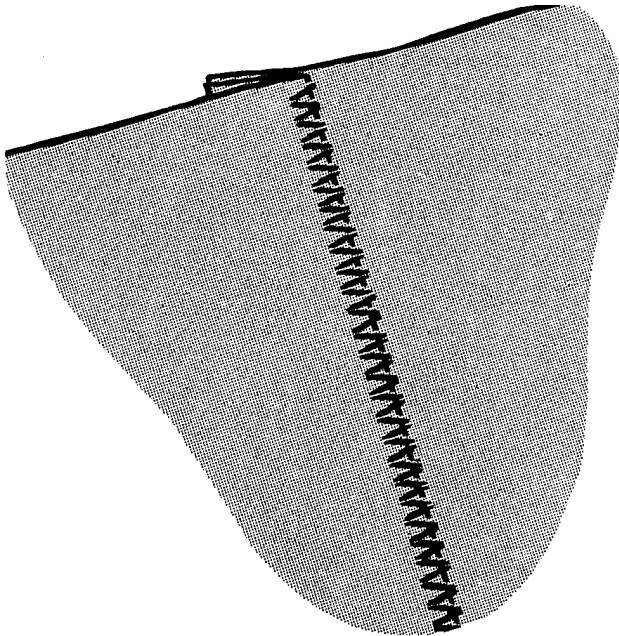

KNIT FABRIC SEAMS

A narrow zigzag stitch is ideal for seaming knit fabrics. It is particularly suitable for underarm seams, or other seams where elasticity and give are needed.

For curved or bias seams, where a stay is needed to prevent undue stretching, this same stitch can be used to apply seam tape.

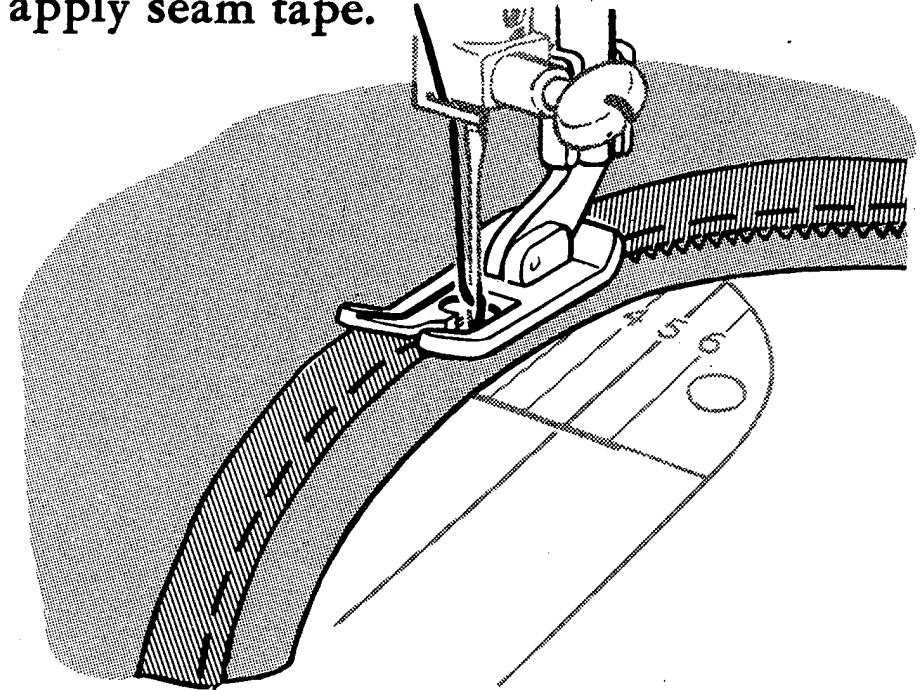

ZIGZAG APPLICATIONS

SEAM FINISHES

Seam edges support garment and should be given a durable finish where fabrics have a tendency to ravel.

The zigzag stitch is ideal for seam finishing. Place stitching near edge of seam allowance, and then trim excess fabric.

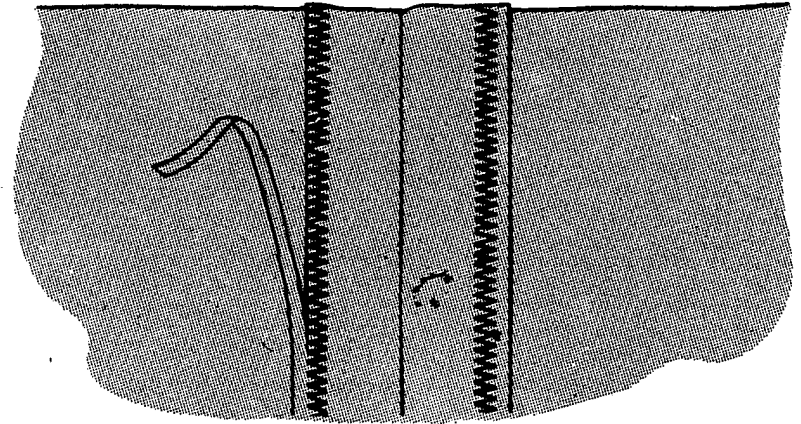

DARTS IN INTERFACING

Interfacing can be shaped without bulk with zigzag stitching. Cut out dart allowance on stitching line and bring raw edges together. Pin over a muslin stay and stitch. Reinforce both ends with reverse stitching.

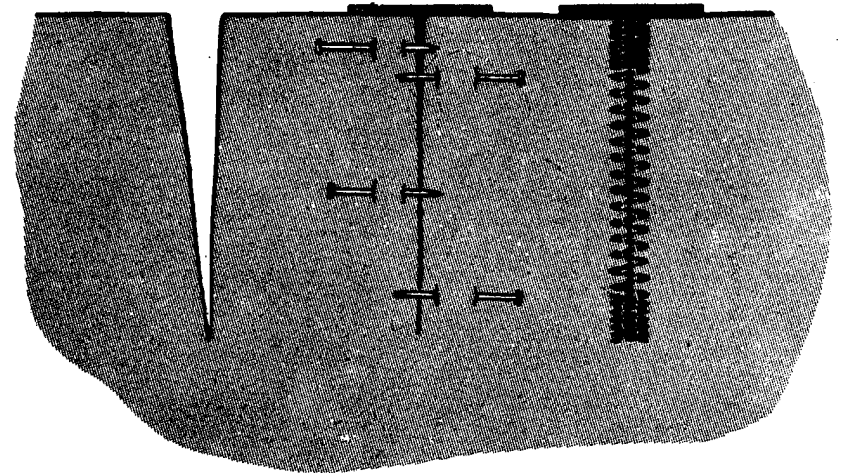

ZIGZAG APPLICATIONS

MENDING

Zigzag stitching is well suited for all types of household mending. It provides a firm, flexible bond for repair of tears and is ideal for reinforcement and application of elastic. Stitch length and width are regulated according to need.

Tears. Trim ragged edges and reinforce tear with underlay. Shorten stitch length at ends and corners for added strength.

Application of Elastic. Elastic must be stretched as it is applied to insure fullness required in the garment.

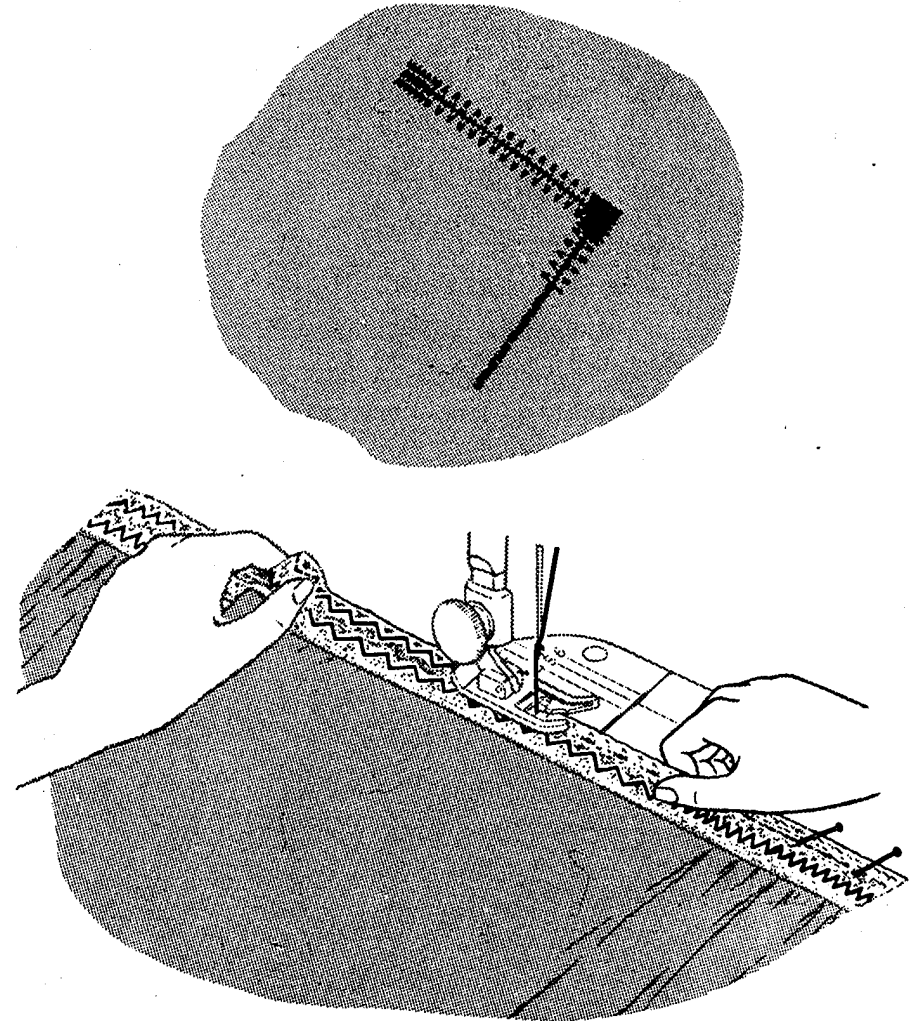

ZIGZAG APPLICATIONS

APPLIQUE

Motifs or designs, applied with a zigzag stitch, add beauty and interest to wearing apparel and household textiles.

Bands, flowers, leaves or figures in contrasting or self fabric, may be effectively applied to another surface by two methods. The appropriate method is determined by the fabric being used. A test sample is advisable.

Method #1

Position and baste design to fabric. Outline entire design with a short straight stitch. Trim raw edges close to stitching. Set stitch width and stitch length for zigzag stitch desired. Over-edge design. This smooth uniform finish requires no additional trimming.

Method #2

Position and outline design as for Method #1. Follow the shape of the design, outlining it entirely with zigzag stitching. Trim away excess fabric on the outer edges of the applique after stitching has been completed.

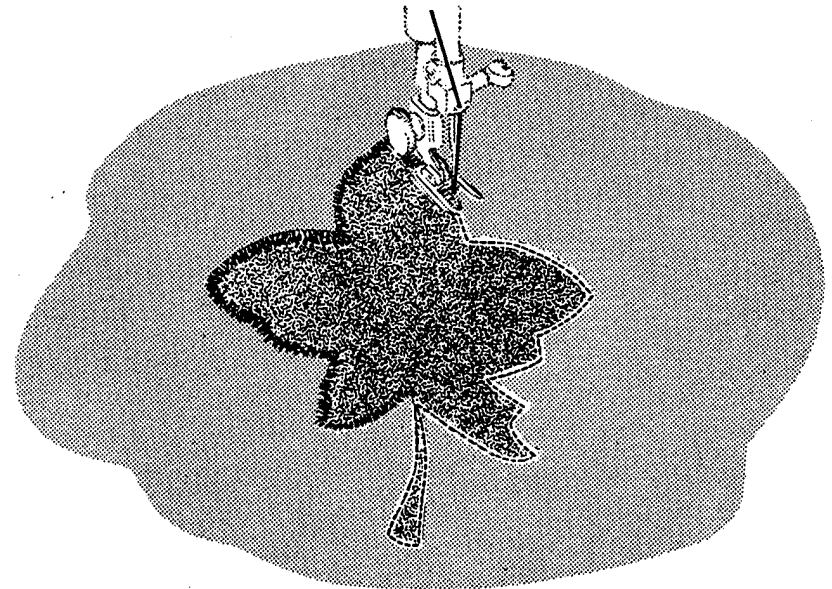

BUTTONHOLES

STITCH LENGTH: ABOVE 20

STITCH WIDTH: 2 AND 4

To establish exact stitch setting and buttonhole length a test sample is advisable. Be sure to use the same fabric and number of fabric layers as in the garment.

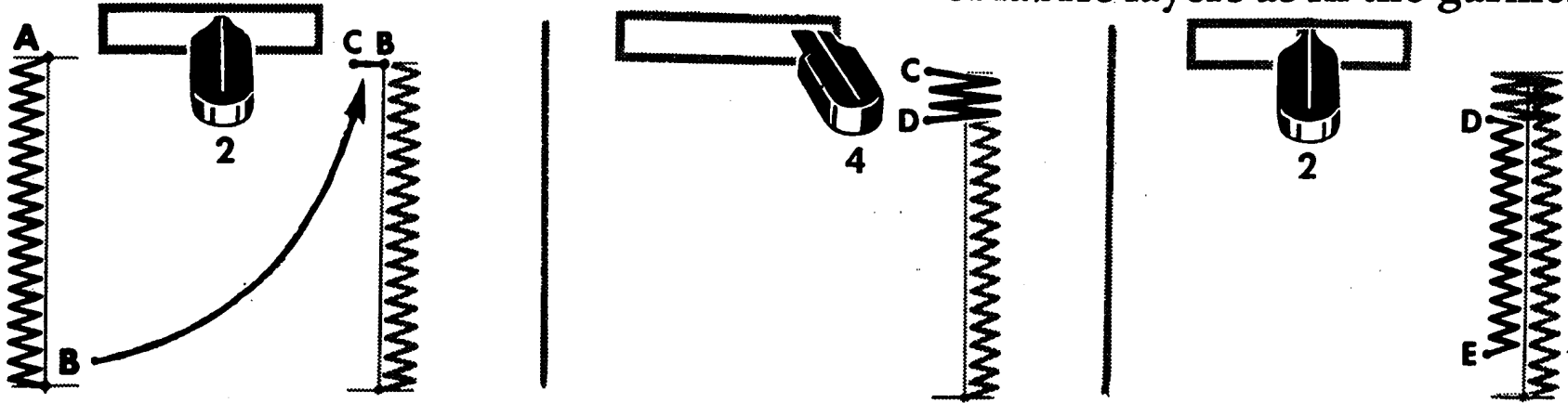

Procedure: Mark button length on garment. Allow $1/8''$ at each end for bar tacks.

Side Stitching: Set stitch width at 2. Stitch down left side starting at point A and stopping at end of marking, point B. Leave needle in fabric. Raise presser foot and pivot work on needle. Lower foot and take one stitch at same width setting. Leave needle in fabric at point C.

Bar Tack: With needle in fabric, raise presser foot and set stitch width at 4. Lower foot and take approximately six stitches to complete tack. Leave needle in fabric at point D.

Side Stitching: With needle in fabric, raise presser foot and re-set stitch width at 2. Lower presser foot and stitch to point E. Leave needle in fabric at point E.

BUTTONHOLES (Cont'd)

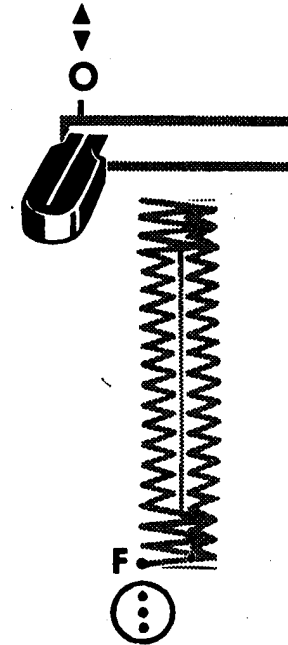
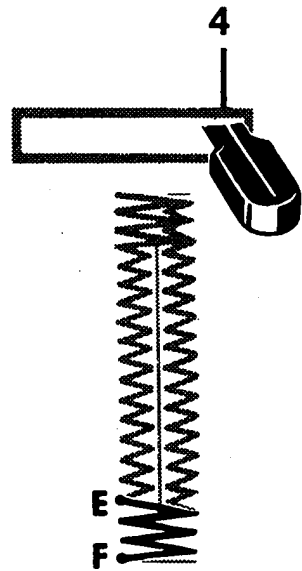

Final Bar Tack: With needle in fabric, raise presser foot and set stitch width at 4. Lower presser foot and duplicate tack previously made. **Leave needle in fabric at point F.**

Fastening Stitch: With needle in fabric, raise presser foot and set stitch width at 0; lower foot, take approximately three stitches.

Remove work, draw threads to wrong side and trim. Cut opening for button with a pair of sharp embroidery scissors.

FASHION AIDS AND ATTACHMENTS

Available for separate purchase at your local SINGER SEWING CENTER

Designed to cut down your sewing time, enlarge the scope of your accomplishment and produce "professional-looking" results, the following attachments are available for your use on the 327 Machine.

THE AUTO-PILOT BUTTONHOLER . . . automatically produces straight and eyelet-end worked buttonholes, embroidered eyelets, and perfectly aligned rectangles of straight stitching for bound buttonholes. Buttonholes may be made in a variety of basic sizes, up to 1½" in length, with the twelve templates that are furnished with the attachment. Additional templates, in sets of four, are available for separate purchase.

THE RUFFLER . . . for gathered and pleated ruffles. Ruffles may be made separately or made and applied in one operation.

THE STRAIGHT STITCH PRESSER FOOT AND THROAT PLATE . . . for delicate and spongy fabrics and for sewing procedures that require close control.

THE SEAM GUIDE . . . aids in maintaining uniformity of seam width.

FASHION AIDS AND ATTACHMENTS (Cont'd)

THE ZIPPER FOOT . . . designed to facilitate the placement of stitching close to a raised edge. Indispensable for zipper insertions, corded seams and slip cover welting.

THE MULTI-SLOTTED BINDER . . . for the application of commercial and self fabric bias binding.

THE FOOT HEMMER . . . forms and stitches a perfect narrow 1/8" hem without pressing or basting.

THE TUCKER . . . a time saver for making tucks 1/8" to 1 inch in width. Gauges tuck width and tuck spacing; marks and stitches in one operation.

THE THROAT PLATE LIFTING PLATE . . . fits under the regular throat plate. Necessary for all free motion techniques.

THE GATHERING FOOT . . . ensures evenly spaced shirring with "locked-in" fullness.

THE EDGE STITCHER . . . regulates the placement of straight stitching in relation to a fabric edge by means of a series of slotted guides.

TO CLEAN THE MACHINE

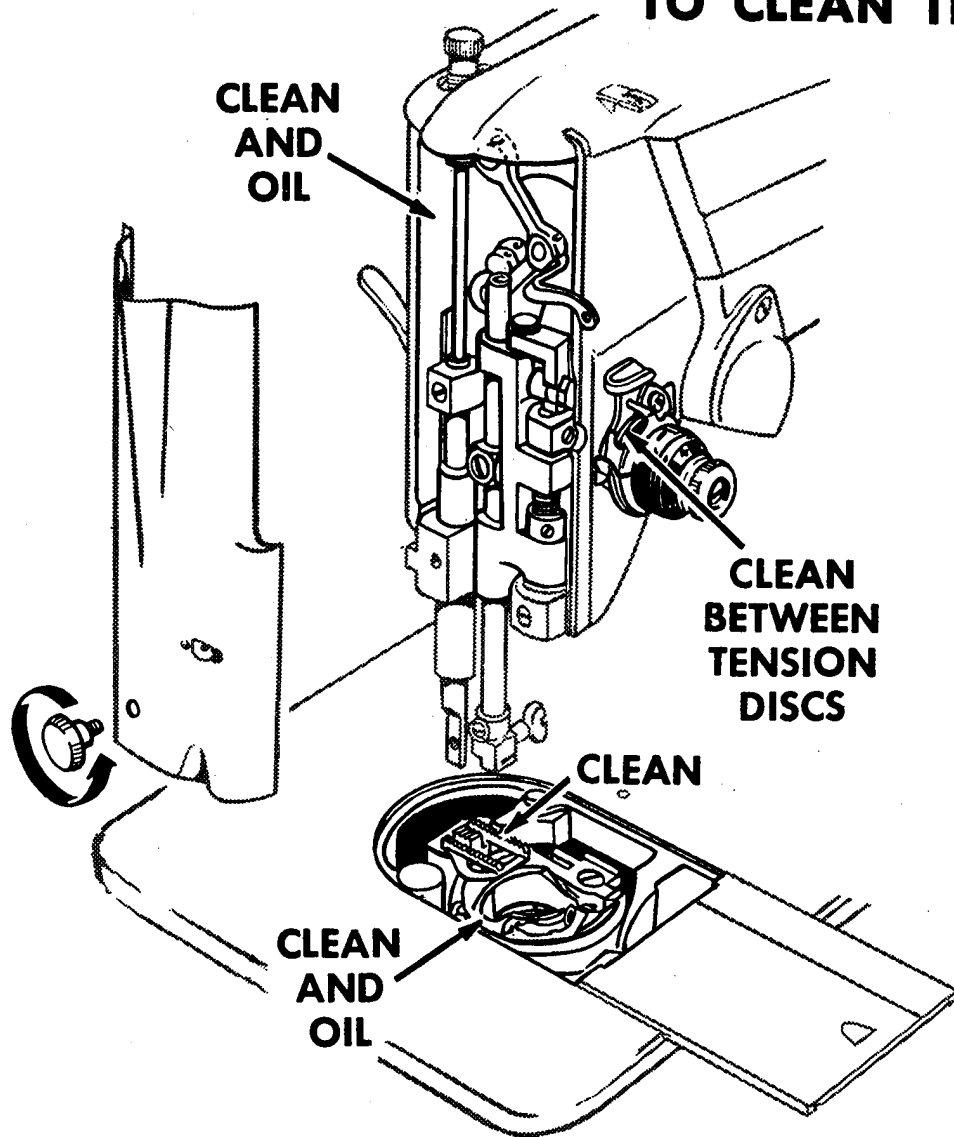

When in regular use

Machine should be cleaned periodically to remove lint and fluff which may have accumulated around working parts. To clean the bobbin case area, the throat plate and bobbin case are removed. See pages 26 and 27 for the removal and replacement of these parts. Oil the machine after each cleaning as instructed on pages 28, 29 and 30.

When stored for an indefinite period

Machine should be given a thorough brush cleaning to remove all traces of lint and fluff, followed by the swabbing of all exposed parts with SINGER* Oil to protect machine against rust damage. The areas to be cleaned and given a protective coating of oil are shown in the illustration at the left.

TO REMOVE AND REPLACE THROAT PLATE

To remove the throat plate

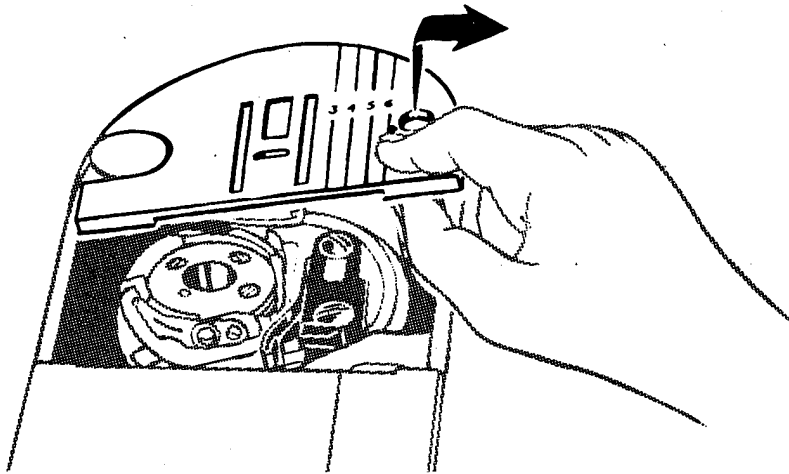

- Raise needle bar and presser foot.
- Open slide plate.
- Place thumb under right front end of throat plate and raise until clamping pin lifts up.
- Draw plate toward right to disengage.

To replace the throat plate

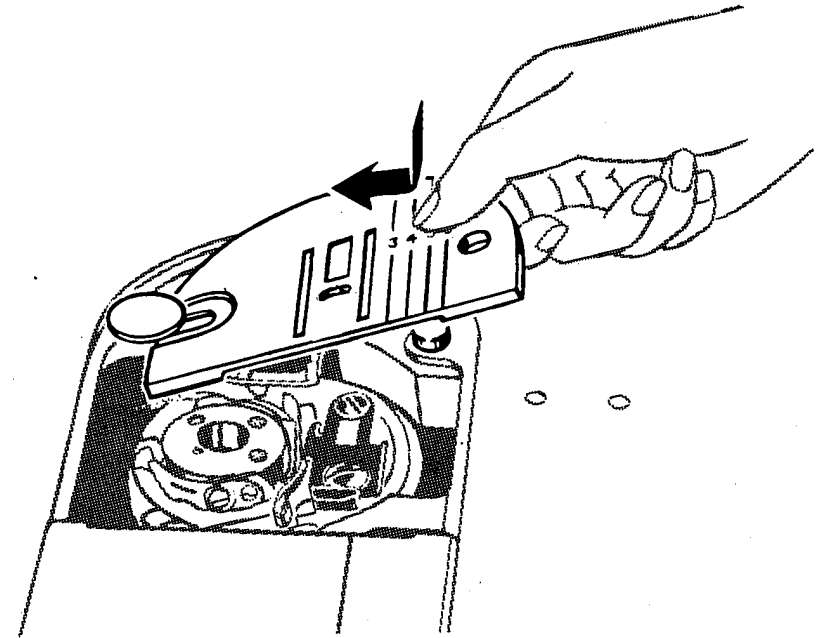

- Position fork of plate under clamping pin as shown above.
- Push to left and press down until plate snaps into position.
- Close slide plate.

TO REMOVE AND REPLACE BOBBIN CASE

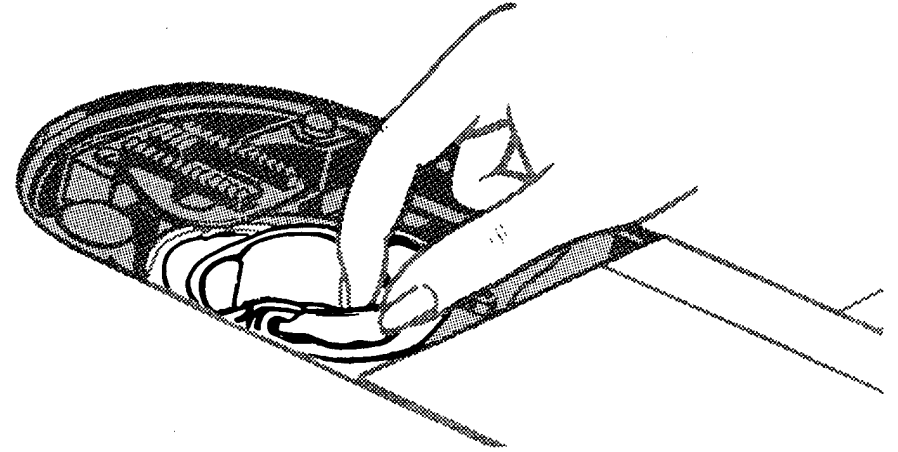
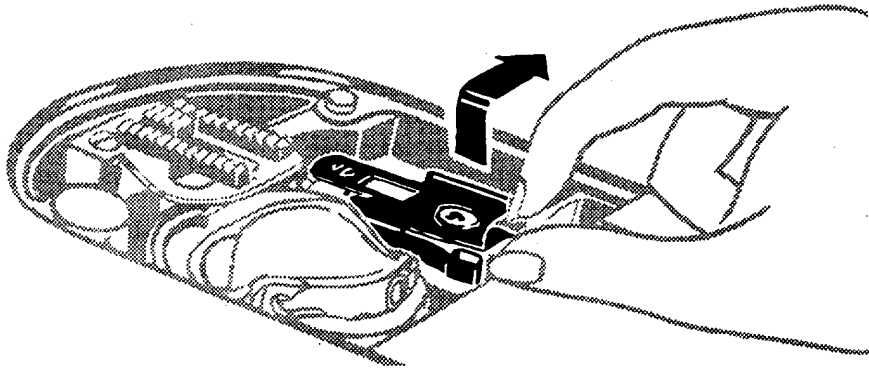

To clean hook raceway

- Open slide plate and remove throat plate (see page 26).
- Unlock bobbin case by lifting and pulling holder to right as shown.
- Remove bobbin case from machine.
- Remove all lint, fluff or other foreign matter which might clog machine.
- Replace bobbin case so that groove under tension spring fits on hook raceway and fork of case straddles positioning stud.
- Push bobbin case holder to left until it snaps down into lock position.
- Replace throat plate; close slide plate.

POSITIONING STUD

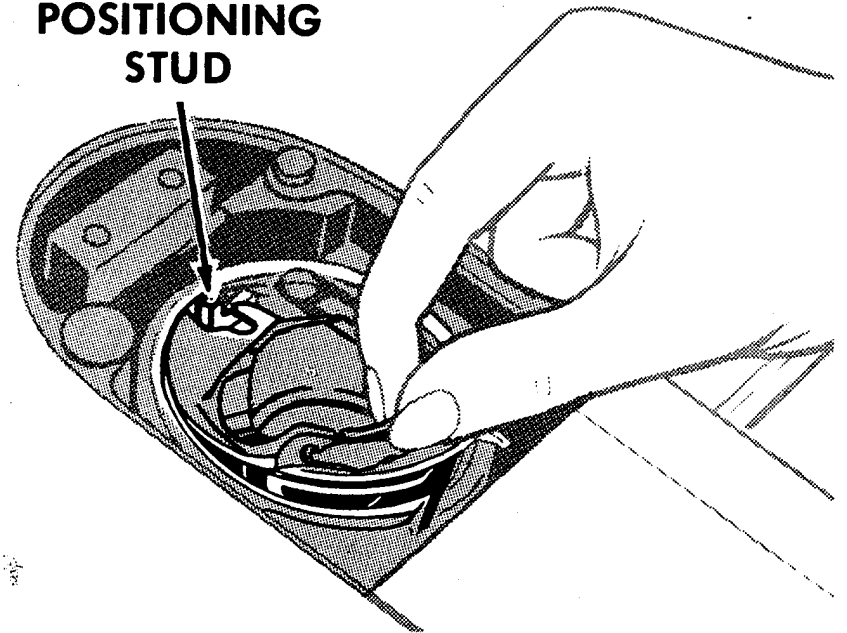

TO LUBRICATE THE MACHINE

To keep your machine in top running condition, use SINGER Oil and SINGER* Lubricant. Both are quality products especially prepared for sewing machines, and should always be used in the care of your 327.

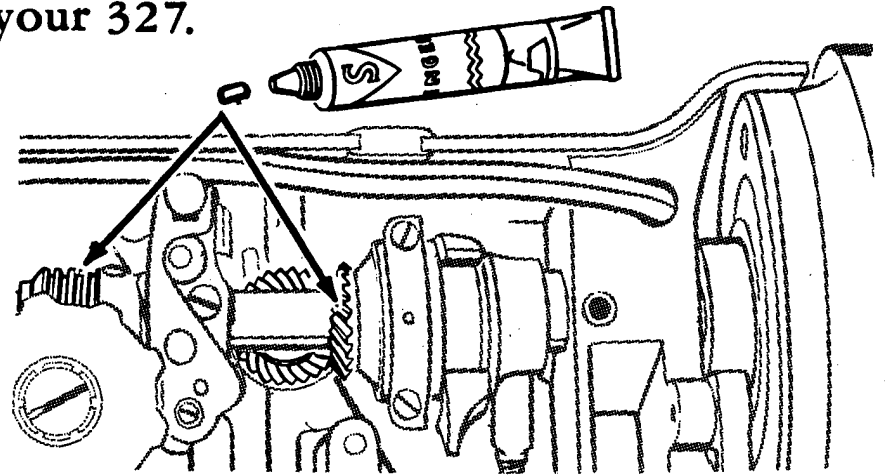
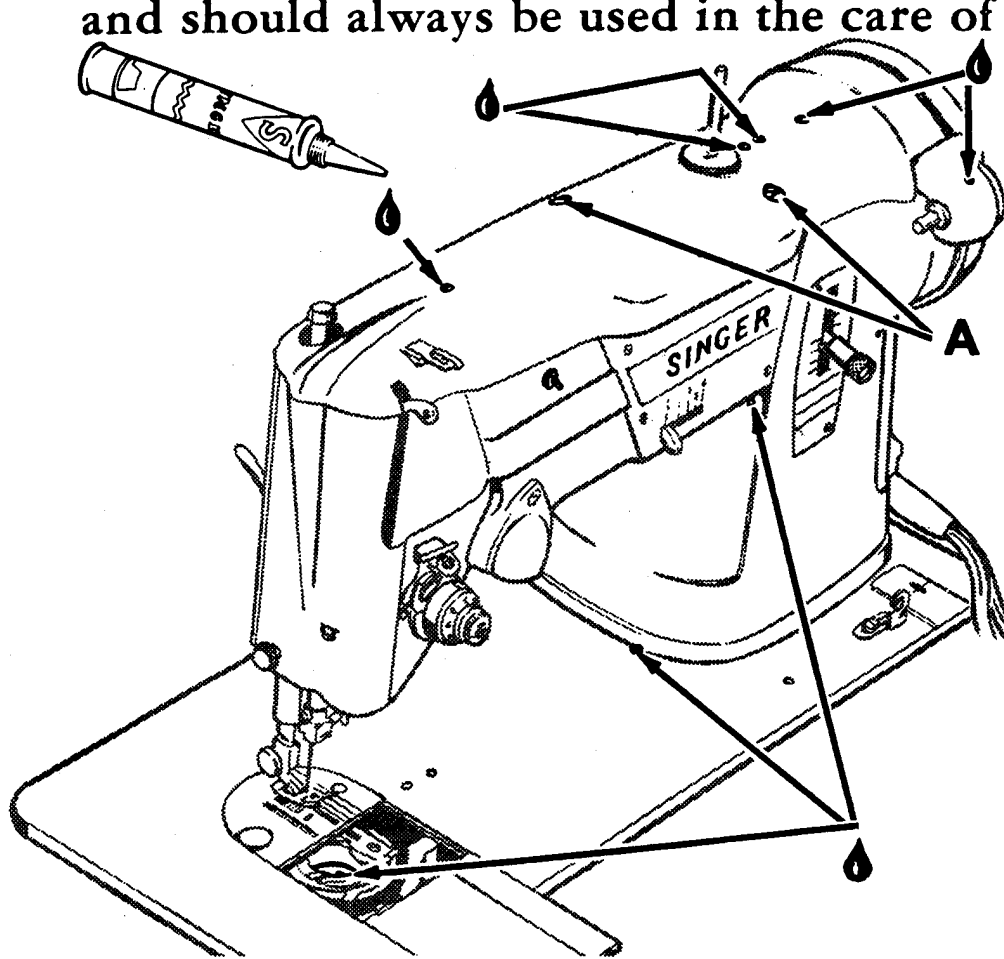

- Clean machine periodically as instructed on page 25.
- Apply a drop of oil to each place indicated.
- Remove screws A and lift off arm top cover.
- Apply a small amount of *lubricant* to gears as shown.
- Replace arm top cover.
NEVER APPLY OIL TO GEARS.

SINGER OIL and LUBRICANT can be purchased at your SINGER SEWING CENTER.

Disconnect Machine from electricity supply before removing Arm Top Cover or Bed Cover Plate.

TO LUBRICATE THE MACHINE (Cont'd)

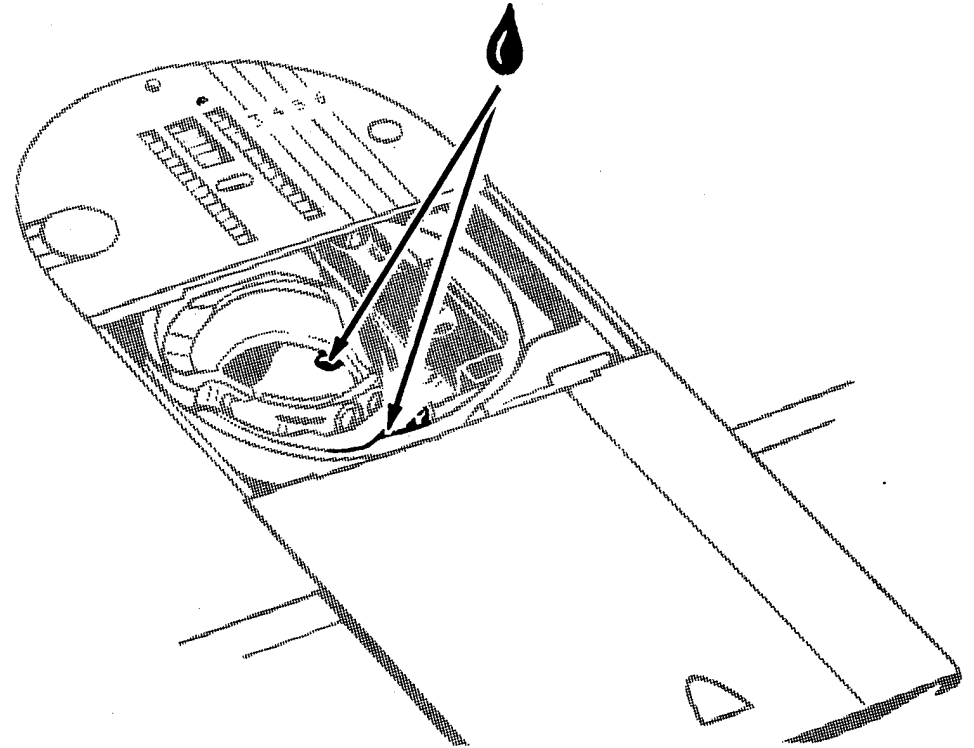
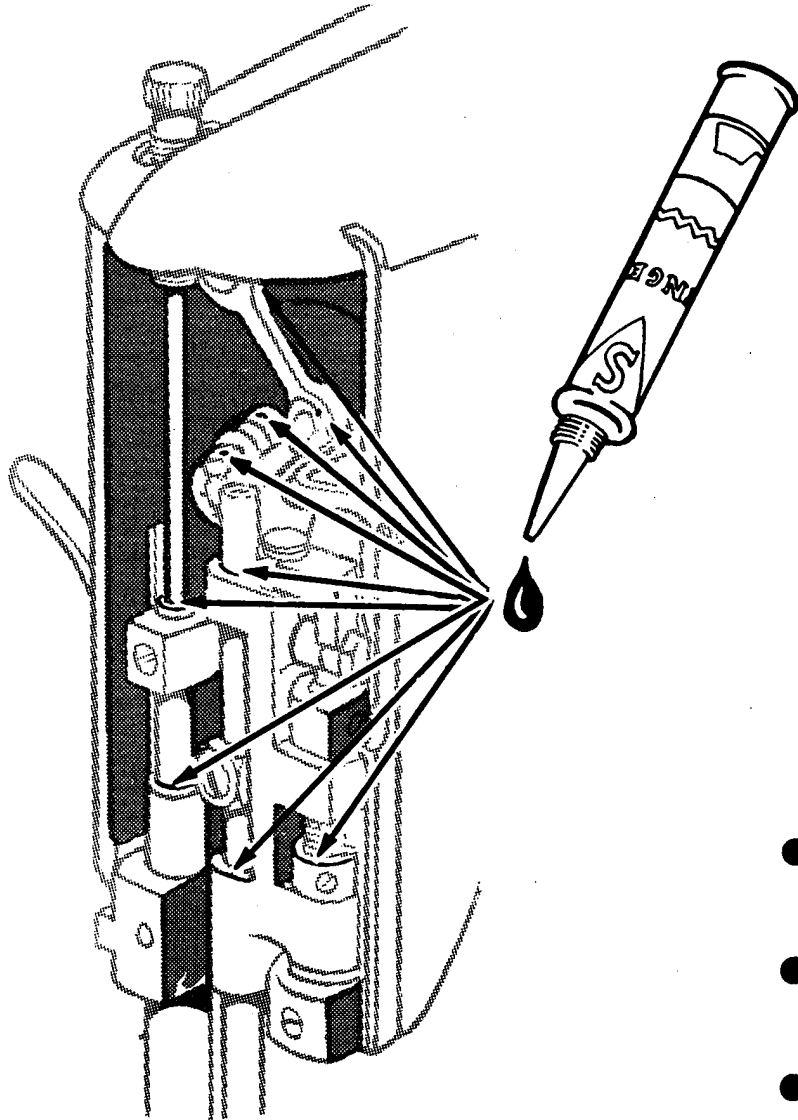

- Remove face plate (see page 25) and oil the places indicated.
- Open slide plate and apply a drop of oil to hook raceway as indicated.
- Close slide plate and replace face plate.

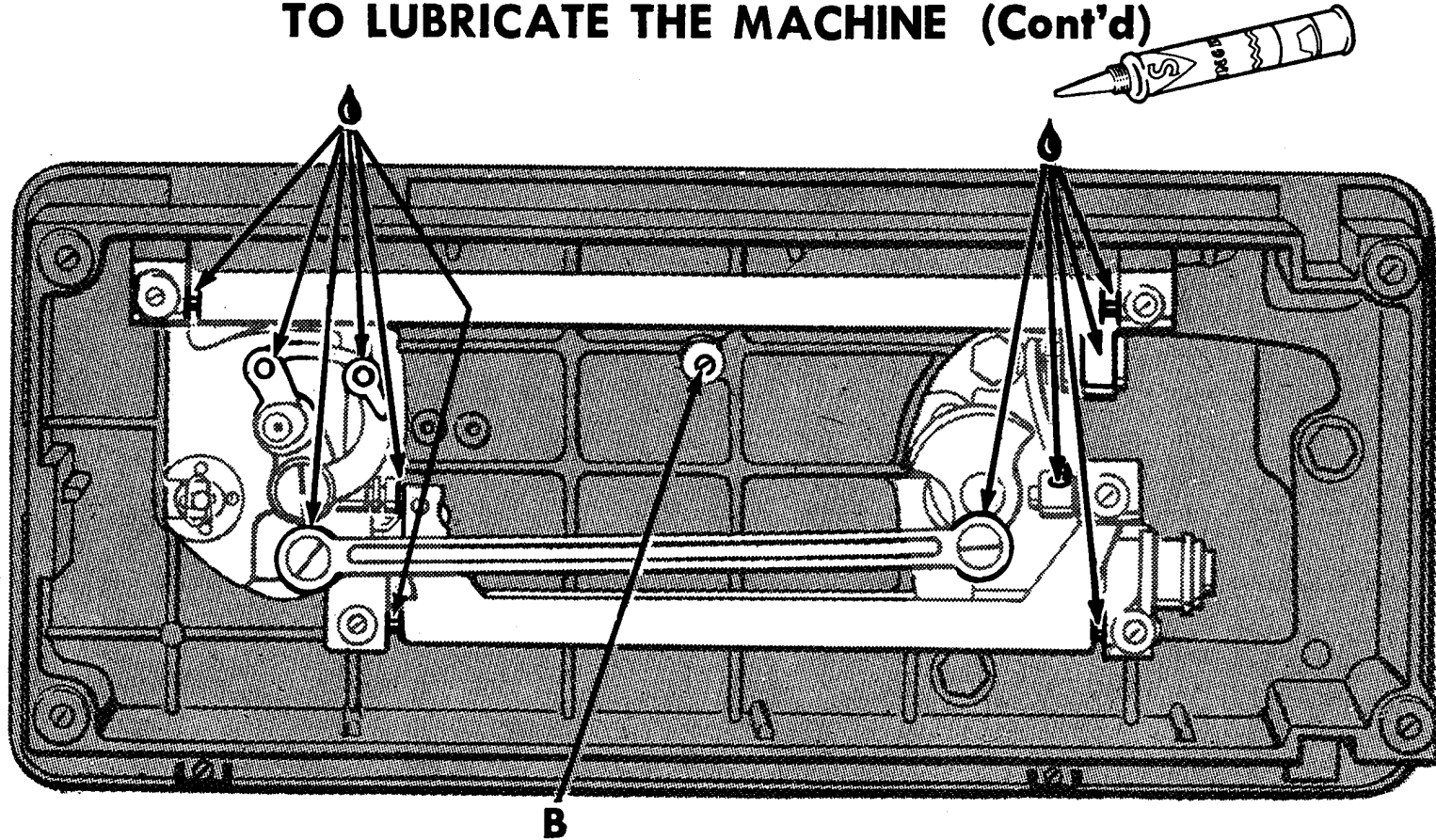
TO LUBRICATE THE MACHINE (Cont'd)

Tilt machine back and remove thumb nut from screw **B**, being careful not to lose felt washer, and remove cover from underside of machine.

Oil each of the places indicated by arrows. Avoid getting oil on any part of the motor.

Replace bottom cover.

THE MOTOR REQUIRES NO LUBRICATION

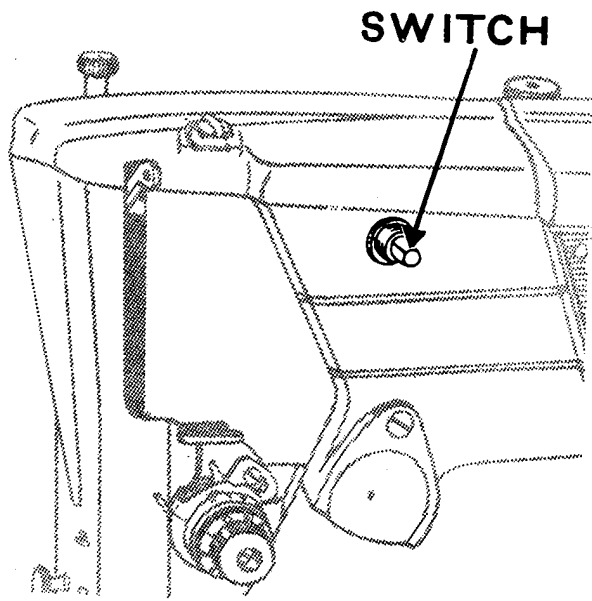

31
LIGHT

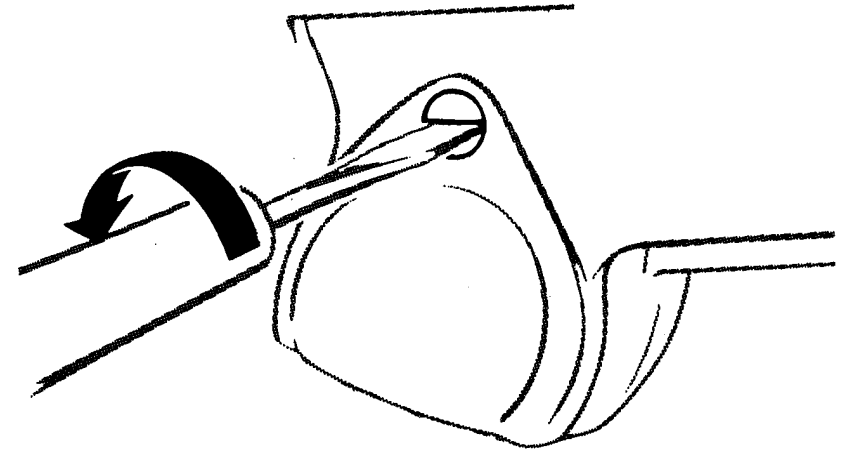

Light Switch. Press in to switch light on; press in again to switch light off.

To Remove Bulb. Remove lamp cover screw and remove lamp cover.

Do not attempt to unscrew bulb. Press it into socket and turn bulb over to the left to unlock bulb pins. Remove bulb.

To Replace Bulb. Press new bulb into socket with bulb pins entering slots of socket. Turn bulb to the right to lock bulb pins in position.

Replace lamp cover and fasten it in position with lamp cover screw.

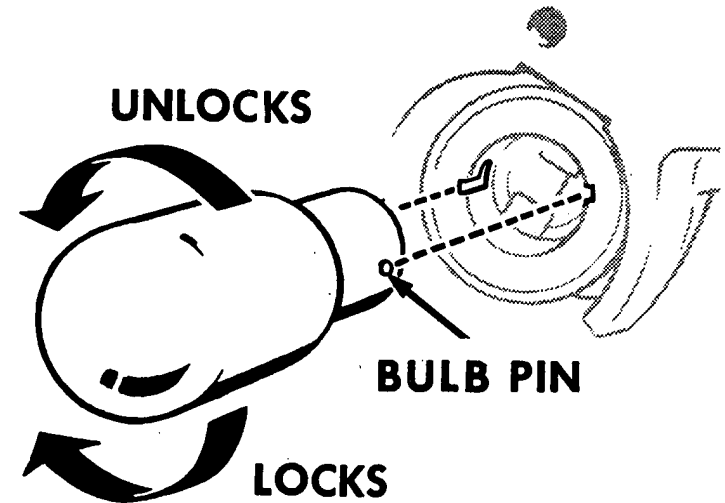

ELECTRICAL INFORMATION

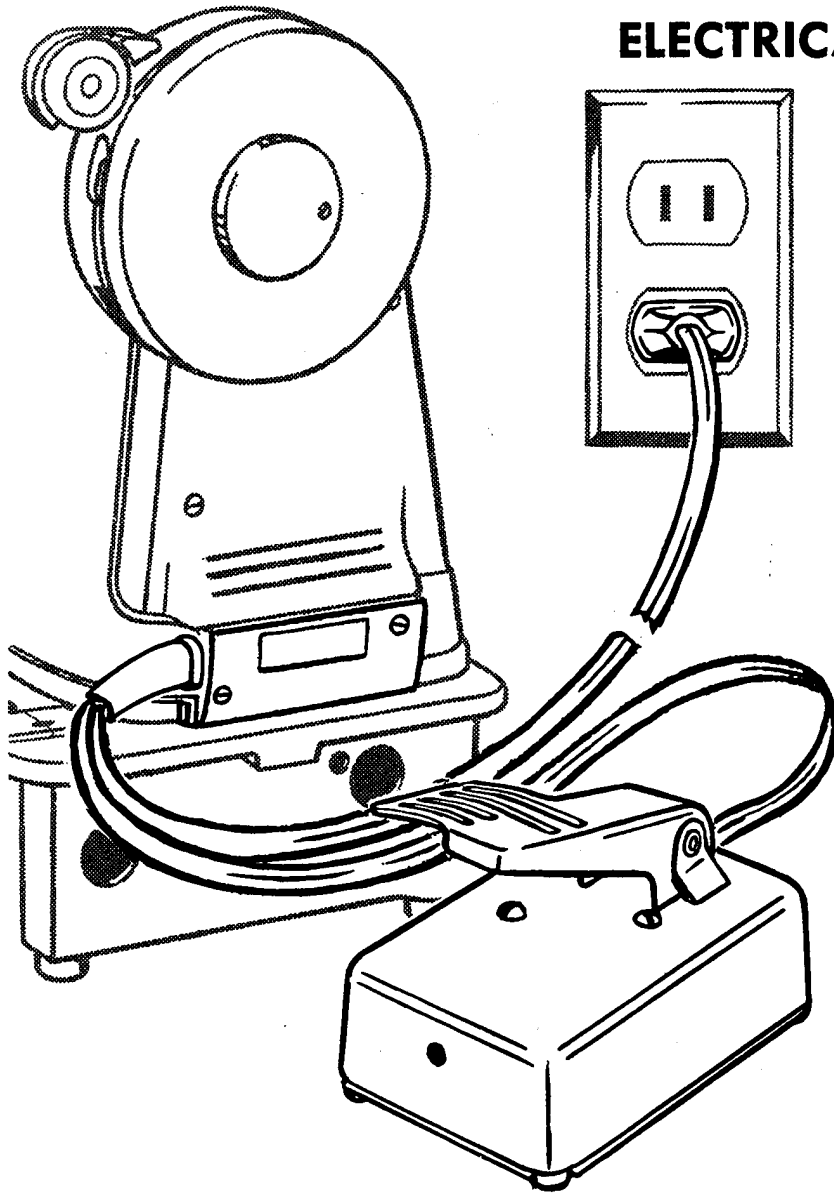

The *SINGER** Electric Motor in your machine is furnished for operation on an alternating current of 110-120 volts, 25 to 75 cycles, or on 110-120 volts direct current. Special motors are available for direct or alternating current for any voltage between 50 and 145, and for 32 volts direct current.

Before Inserting Electric Plug, be sure that voltage and cycles stamped on terminal cover are within range marked on your electrical meter installed by your power company.

Electrical Connection. Insert plug into nearest electrical outlet and the machine is ready for operation.

Speed Controller. Speed of machine is regulated by amount of pressure on pedal of foot controller or knee lever.

CAUTION: Do not attempt to remove the Motor Cover Plate.

To all whom it may concern:

The improper placing or renewal of the trademark "**SINGER**" or any other of the trademarks of The Singer Company (all of which are duly Registered Trademarks) on any machine that has been repaired, rebuilt, reconditioned, or altered in any way whatsoever outside a SINGER factory or an authorised SINGER agency is forbidden.

For your protection

SINGER Sewing Machines are sold and serviced wherever you see the famous SINGER and Red "S" Trademarks. When your machine needs servicing call your SINGER SEWING CENTER to be sure of warranted SINGER parts and service. See address in the classified telephone directory.

T H E S I N G E R C O M P A N Y